

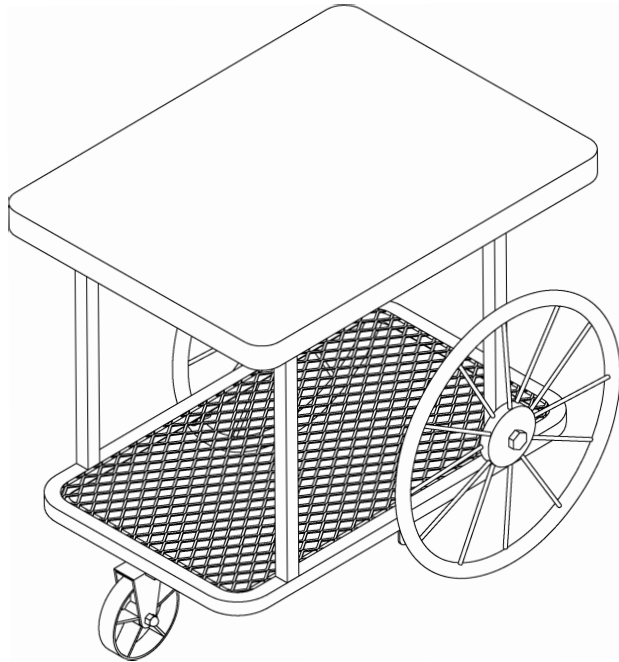

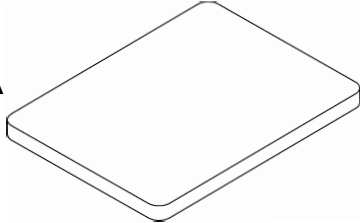

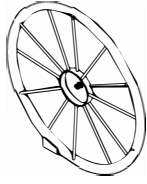

ASSEMBLY INSTRUCTIONS

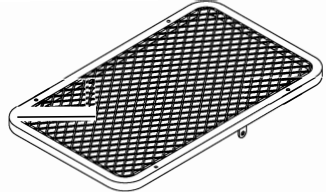

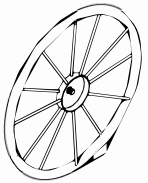

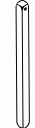



Do not tighten screws until completely assembled.

PARTS IDENTIFICATION

<p>A  1pc</p>	<p>D  1pc</p>
<p>B  1pc</p>	<p>E  1pc</p>
<p>C  1pc</p>	<p>F  1pc</p> <p>G  2pcs</p> <p>H  2pcs</p>

HARDWARE LIST

<p>1  3pcs M6x15</p>	<p>2  10pcs M6x35</p>	<p>3  1pc 4x4</p>
<p>4  1pc M8x40</p>	<p>5  1pc</p>	<p>6  1pc 5x5</p>

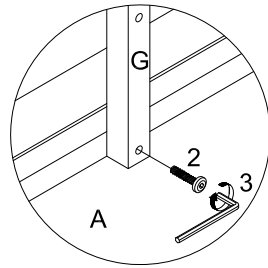
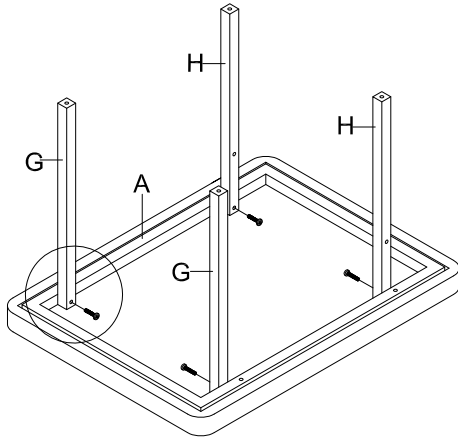

STEP 1.

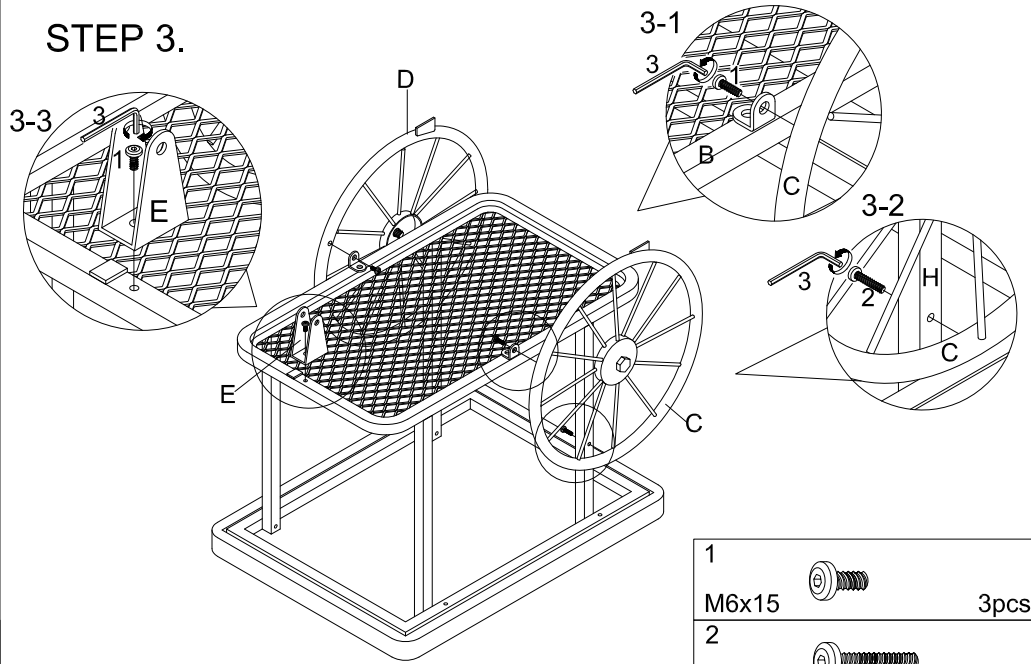

2
M6x35  4pcs

STEP 3.



1		M6x15	3pcs
2		M6x35	2pcs

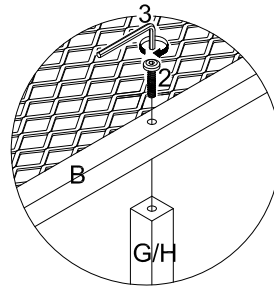
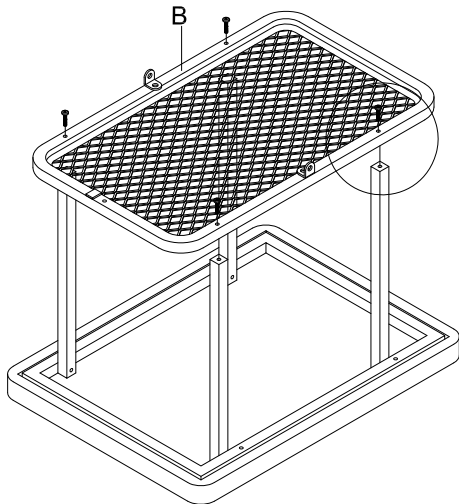

STEP 2.

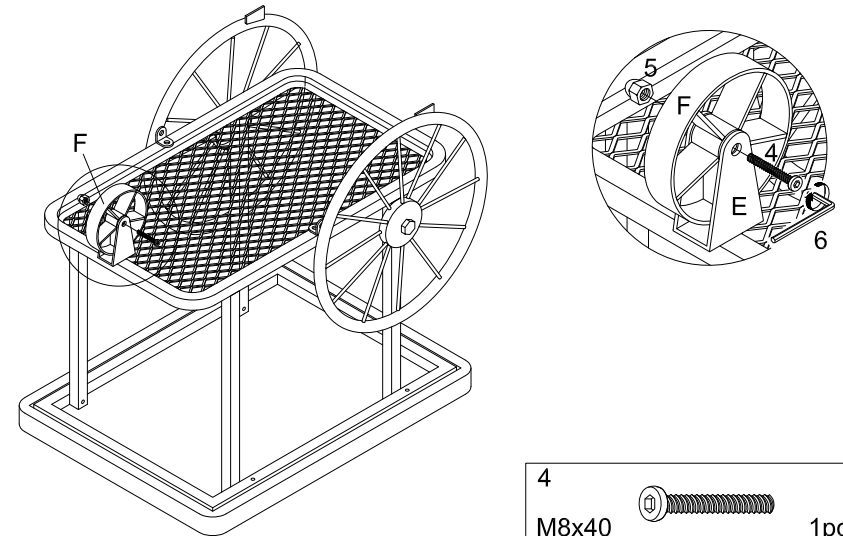

2
M6x35  4pcs

STEP 4.



4		M8x40	1pc
5			1pc