

ASSEMBLY INSTRUCTIONS

Item Number **WF531361**

WF531362

This set comes in 2 boxes. If you do not receive a full 2 boxes, please contact our customer service.

Upholstered bed-135*190CM

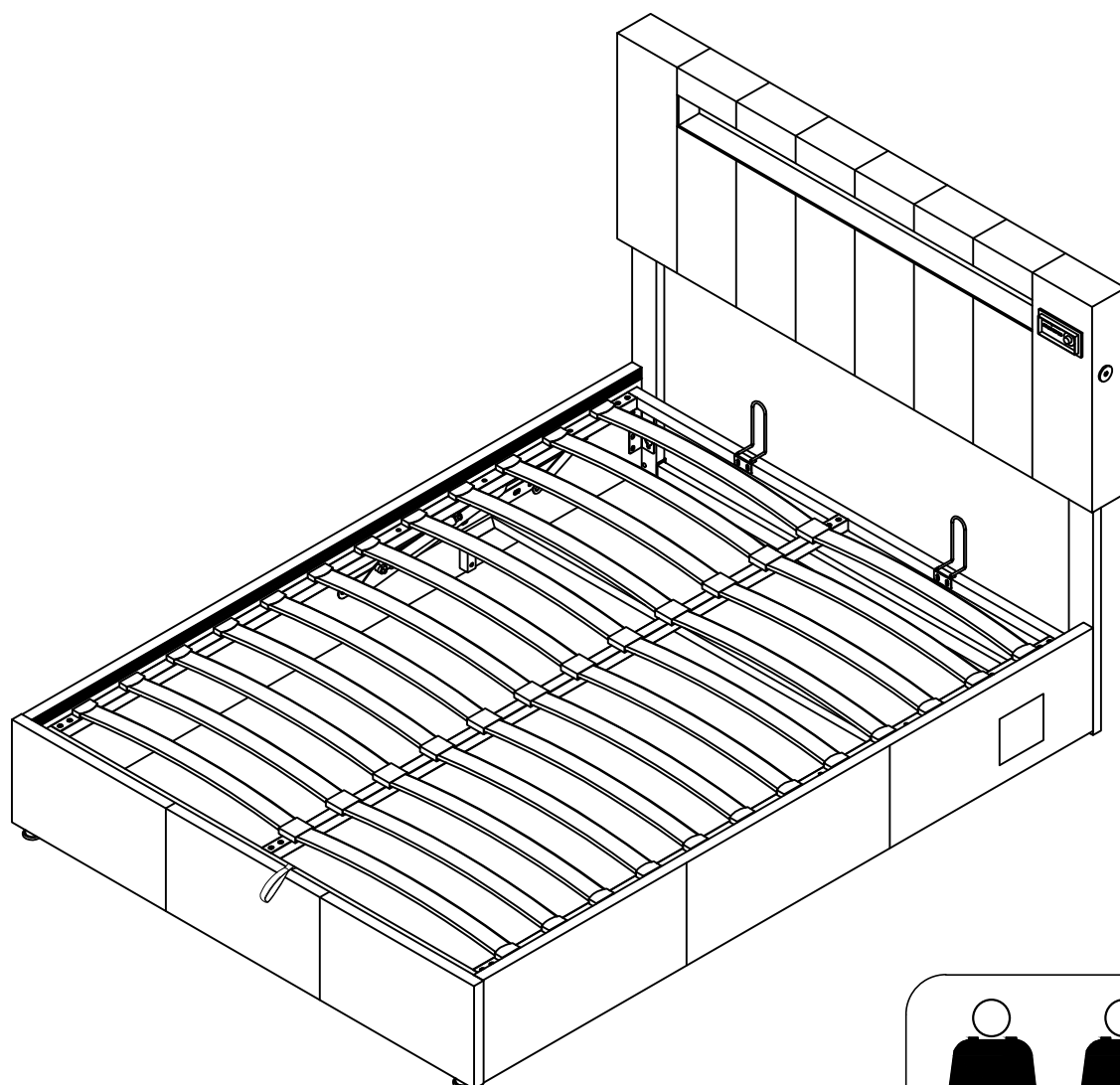

**UK
CA**

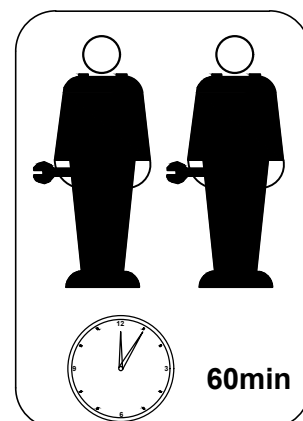
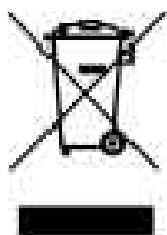

INSTRUCTIONS

IMPORTANT-READ CAREFULLY-RETAIN FOR FUTURE REFERENCE

- a) WARNING** -Children can become trapped between the bed and the wall, the adjoining pieces of furniture (e.g. cupboards) and the lke. To avoid risk of serious injury the distance between the safety barrier and the adjoining structure shall not exceed 75 mm or shall be more than 230 mm.
- b) WARNING**-Do not use the bed if any structural part is broken or missing; Replacement parts are between requested from the manufacturer or the store.
- c) WARNING**-Do not climb or wiggle on any non-designated structures.
- d)** it is imperative to always follow the installation instructions and manufacturer's use.
- e)** The recommended size of the mattress to be used with the bed is 135cmx190cm,maximum thickness mattress:25cm.
- f)** It is necessary to ventilate the room in order to maintain a low level moisture and prevent mold growth in the bed and its periphery.
- g)** Joining devices should always be tightened properly and regularly verified. Tighten if necessary.

Part list WF531361

Aa

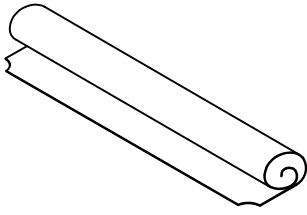

Non-woven Fabric-1PC

Ab

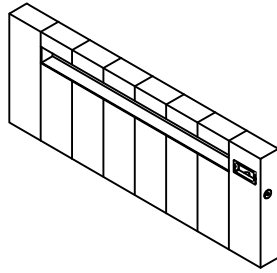

Headboard-1PC

B

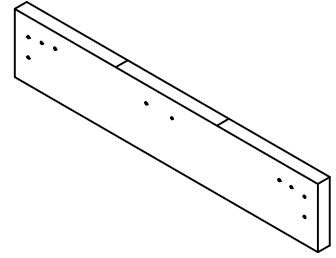

Footboard-1PC

C1

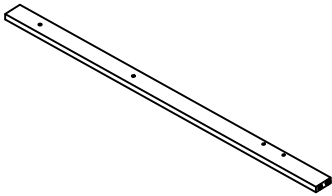

Leg Headboard (L)-1PC

C2

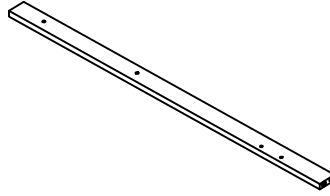

Leg Headboard (R)-1PC

E

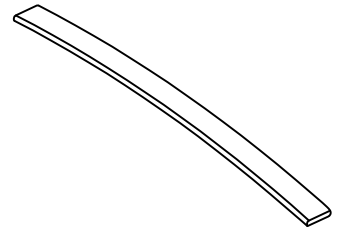

Slat-24PCS

Ha

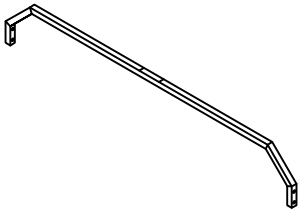

Bar Rail-1PC

H1

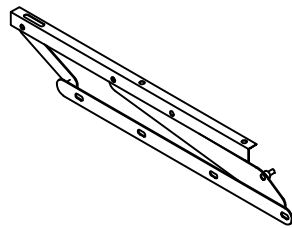

Hydraulic (L)-1PC

H2

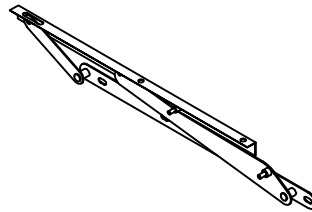

Hydraulic (R)-1PC

N1

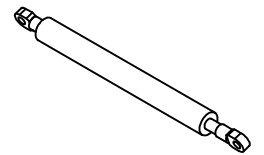

Hydraulic Bar-2PCS

N

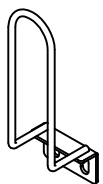

Block Bar-2PCS

O

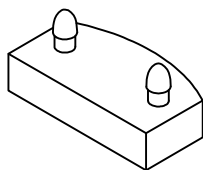

Plastic caps (Single)-24PCS

P

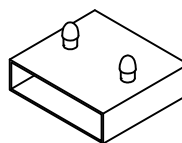

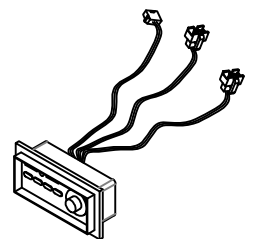

Plastic caps (Double)-12PCS

K1





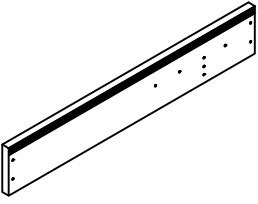
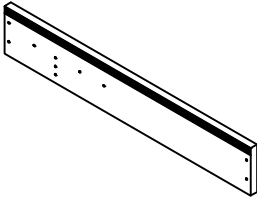
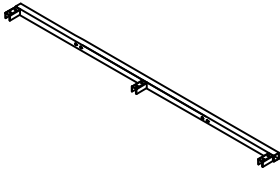
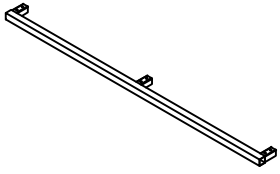
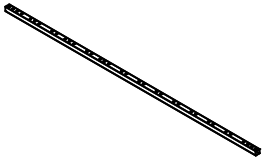
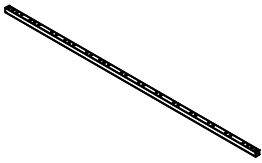
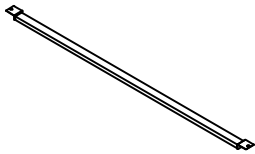
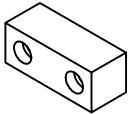
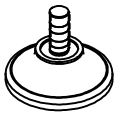
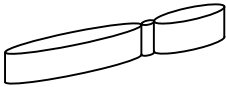
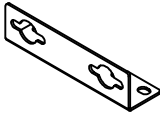
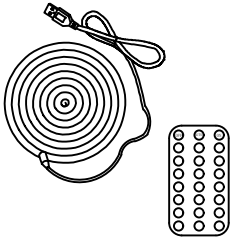

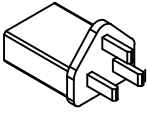

loudspeaker box-1PC

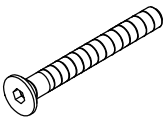
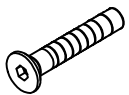
Part list WF531362

<p>D1</p>  <p>Facing customer Side Rail(L)-1PC</p>	<p>D2</p>  <p>Facing customer Side Rail(R)-1PC</p>	<p>F1</p>  <p>connect HB Front Rail-1PC</p>	<p>F2</p>  <p>connect FB Back Rail-1PC</p>
<p>G1</p>  <p>Side tube-2PCS</p>	<p>G2</p>  <p>Middle Rail-1PC</p>	<p>Hb</p>  <p>Bottom Rail-1PC</p>	<p>I</p>  <p>Plastic Block-3PCS</p>
<p>M</p>  <p>Legs-2PCS</p>	<p>Q</p>  <p>Straps-1PC</p>	<p>L</p>  <p>Indices "L"-4PCS</p>	<p>J</p>  <p>HB light-1PC</p>
<p>K2</p>  <p>Power line-1PC</p>	<p>K3</p>  <p>Adapter-1PC</p>		

Hardware list WF531362

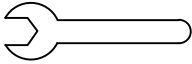

<p>R</p>  <p>M8*50mm 10PCS</p>	<p>S</p>  <p>M8*45mm 14PCS</p>	<p>T</p>  <p>M8*25mm 26PCS</p>	<p>U</p>  <p>M8*18mm 12PCS</p>	<p>V</p>  <p>M8 14PCS</p>
<p>W</p>  <p>φ17*φ8.5 6PCS</p>	<p>X</p>  <p>φ22*φ8.5 4PCS</p>	<p>Y</p>  <p>M8 1PC</p>	<p>Z</p>  <p>M8 1PC</p>	

Detail View

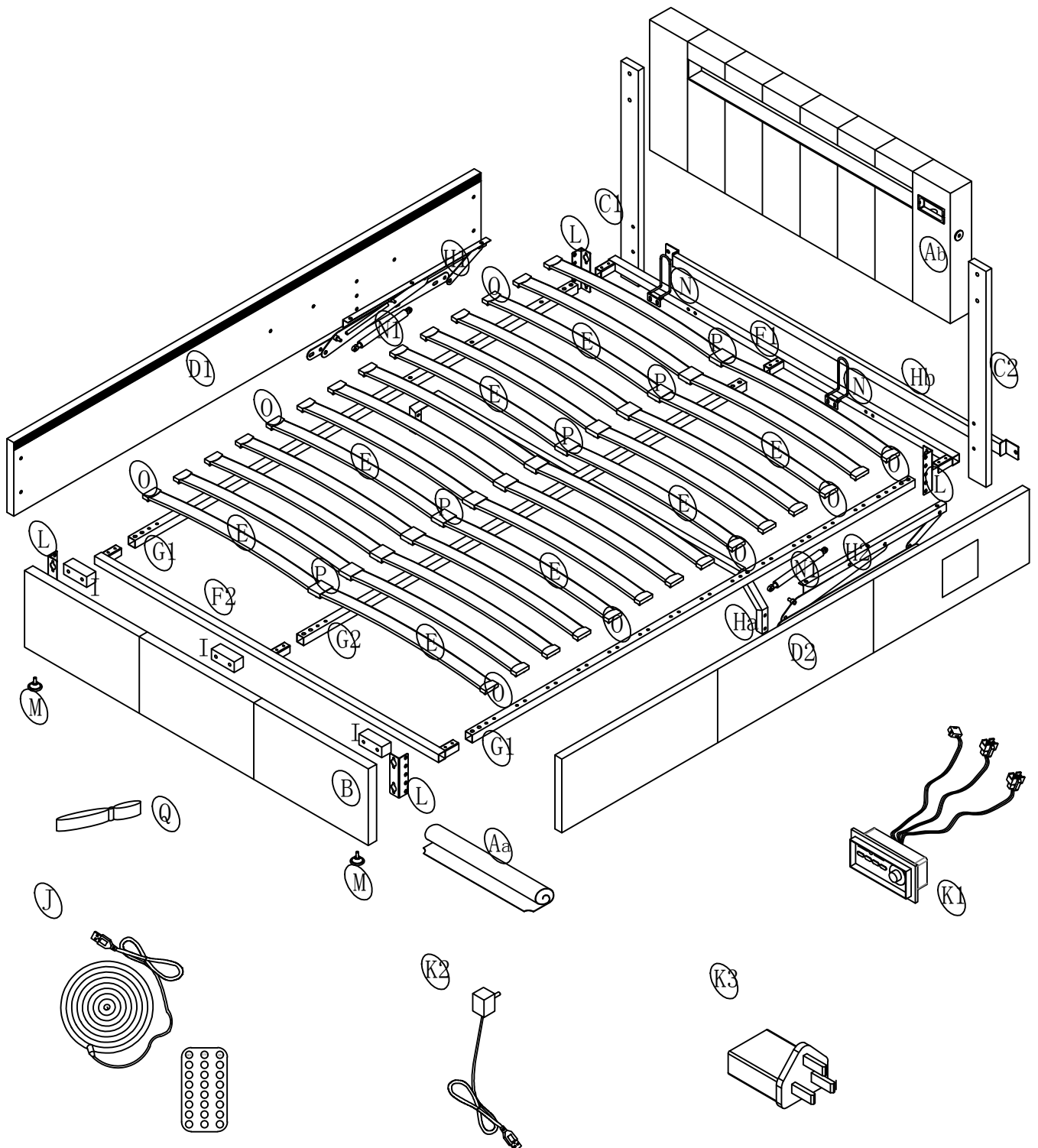
NOTE: Please do not completely tighten all the hardware until the entire assembly is complete!

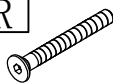

step1

R	X
	
4PCS	4PCS

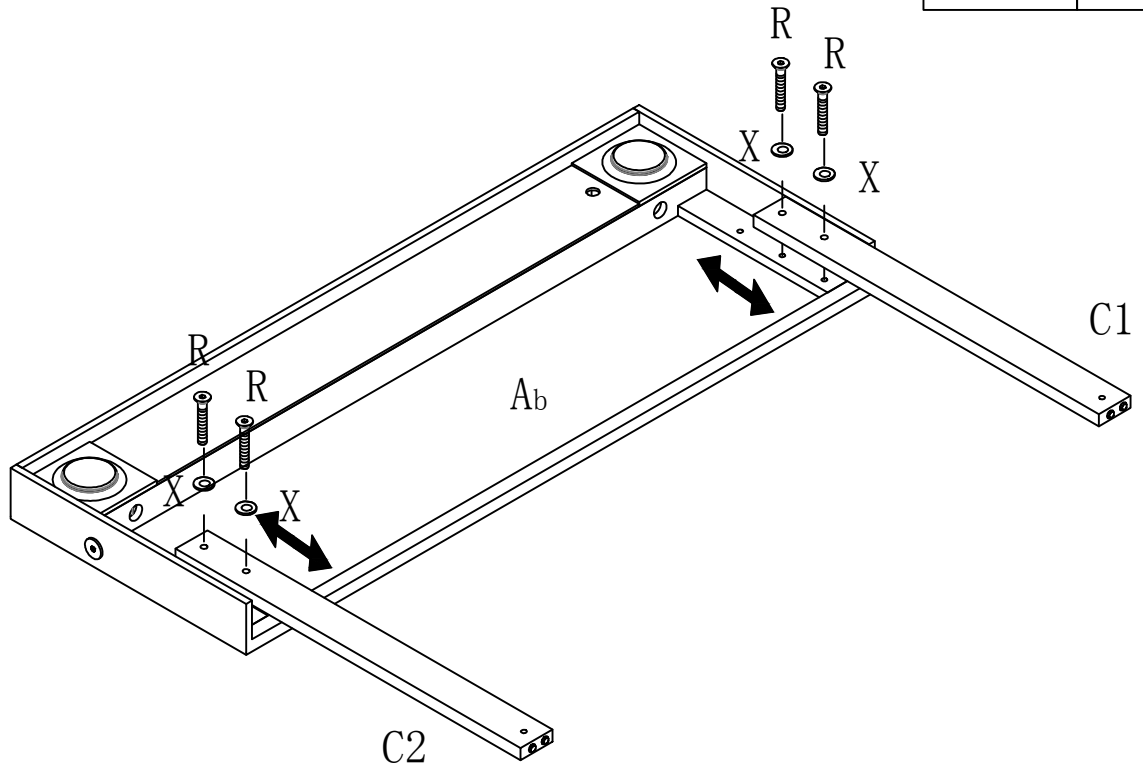

Headboard height is adjustable

step2

T

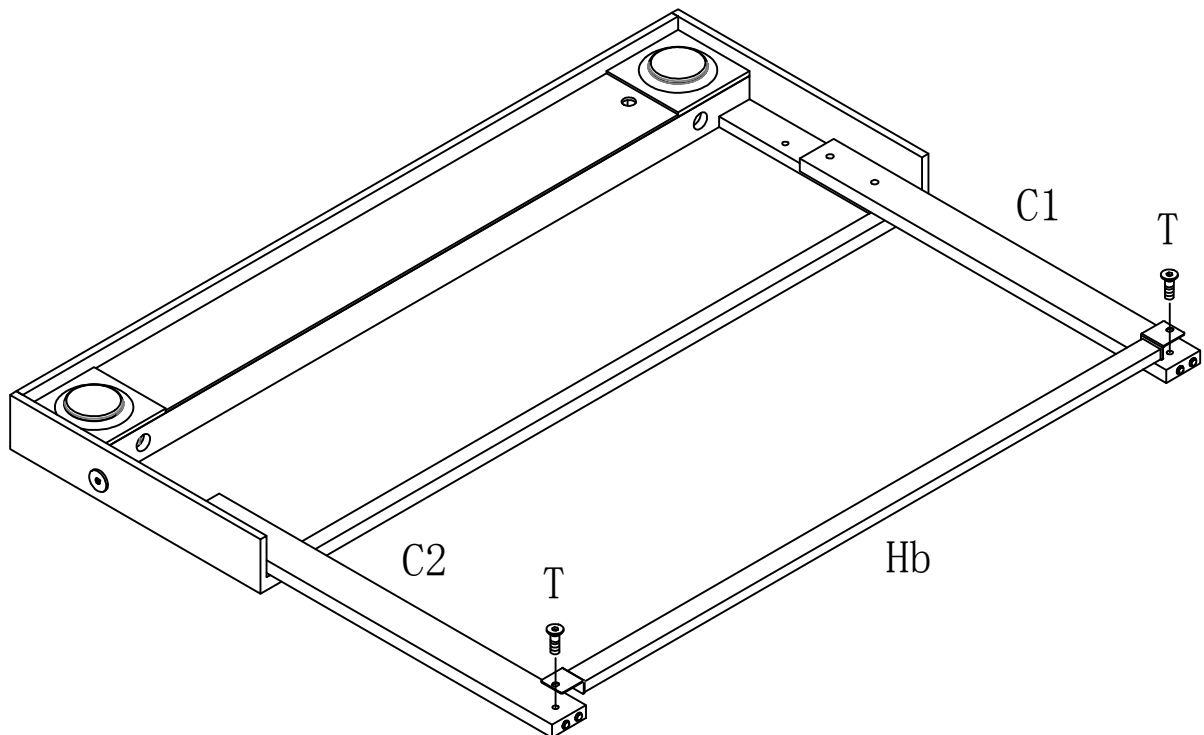
2PCS

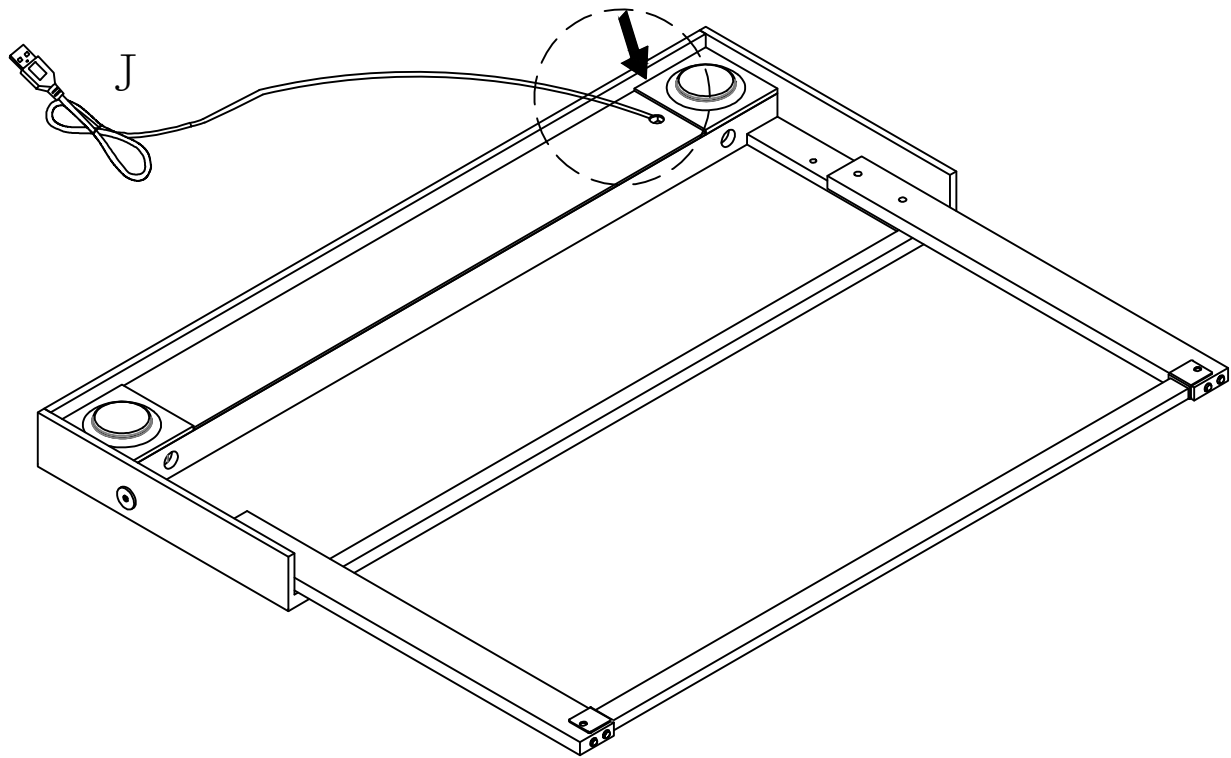

step3

J	
1PC	



step4

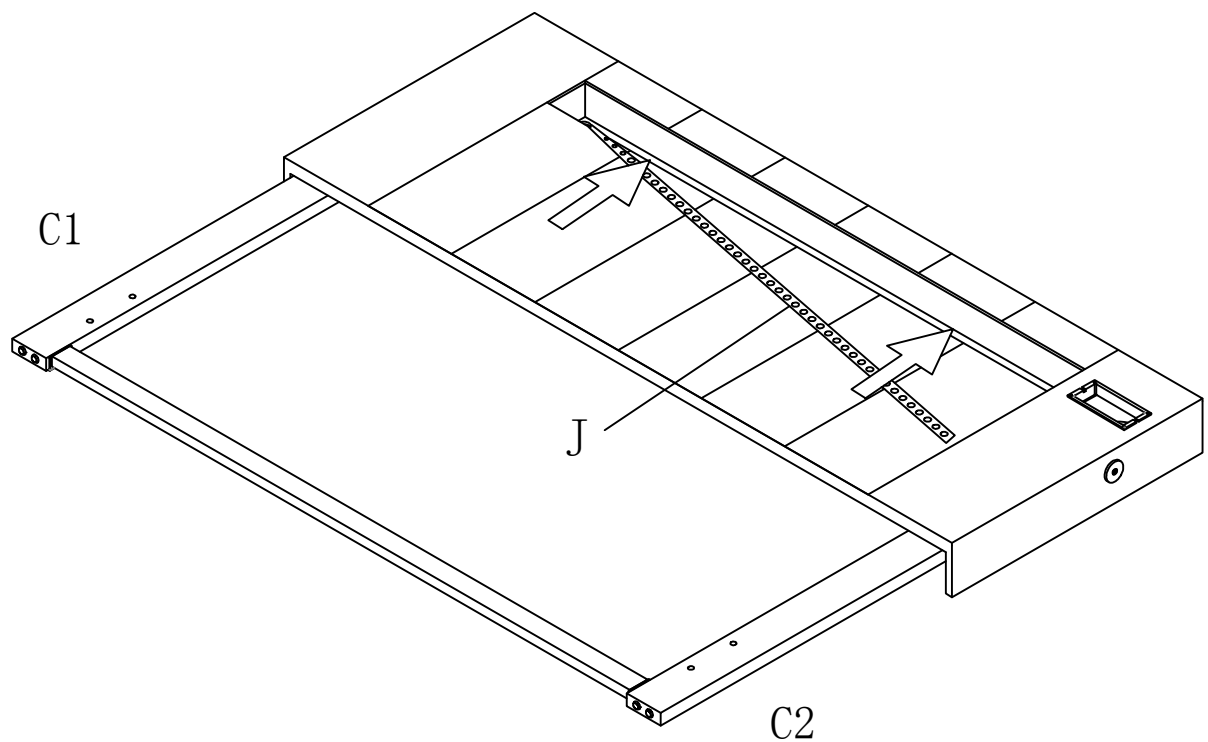

step5

T



8PCS

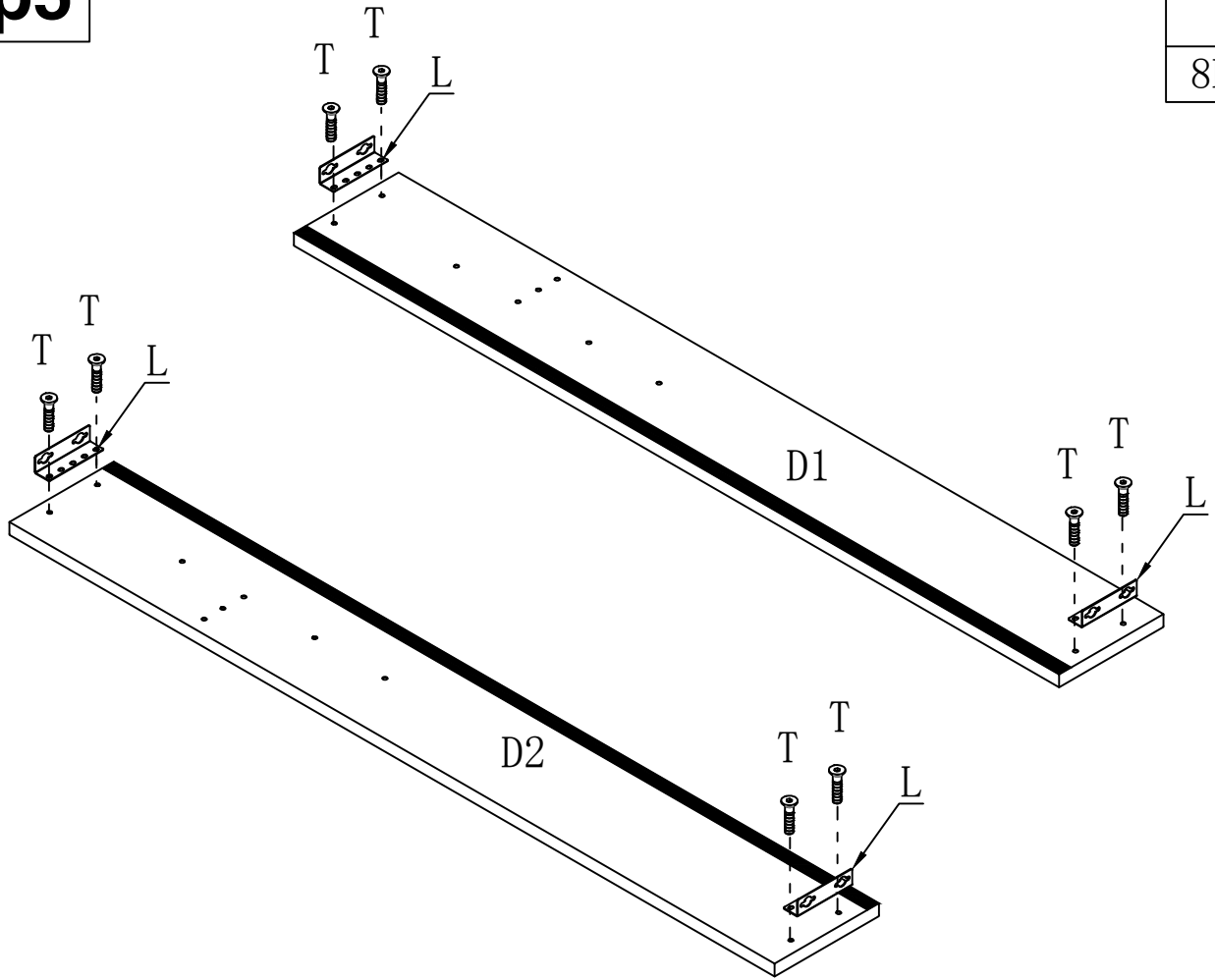

step6

M



2PCS

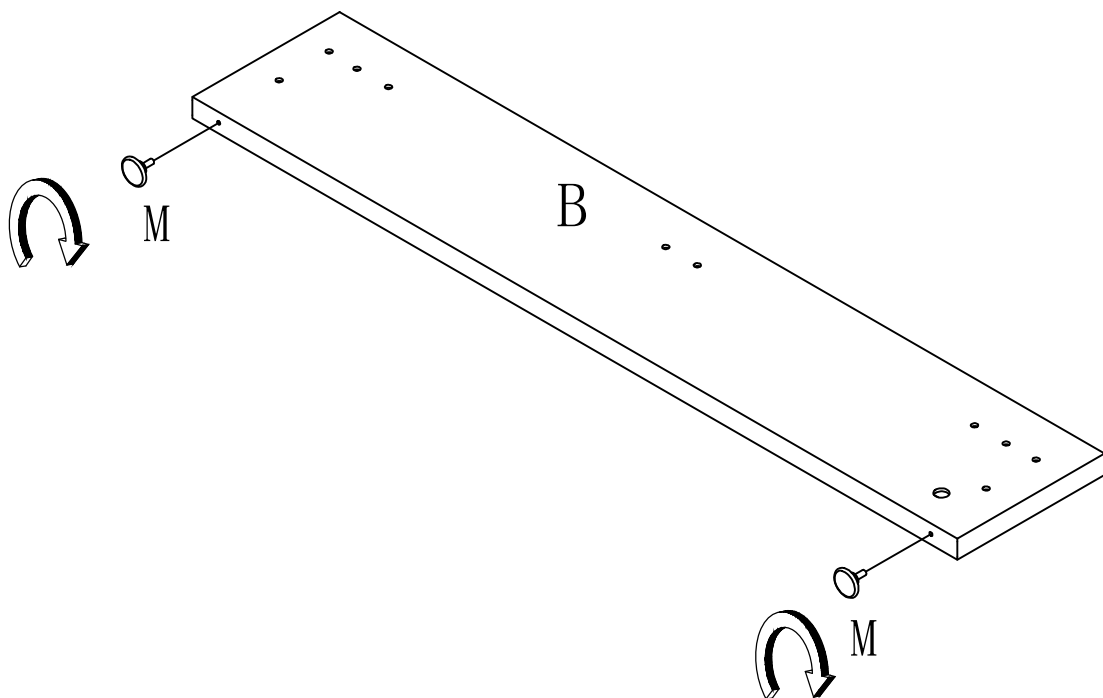

step7

T



8PCS

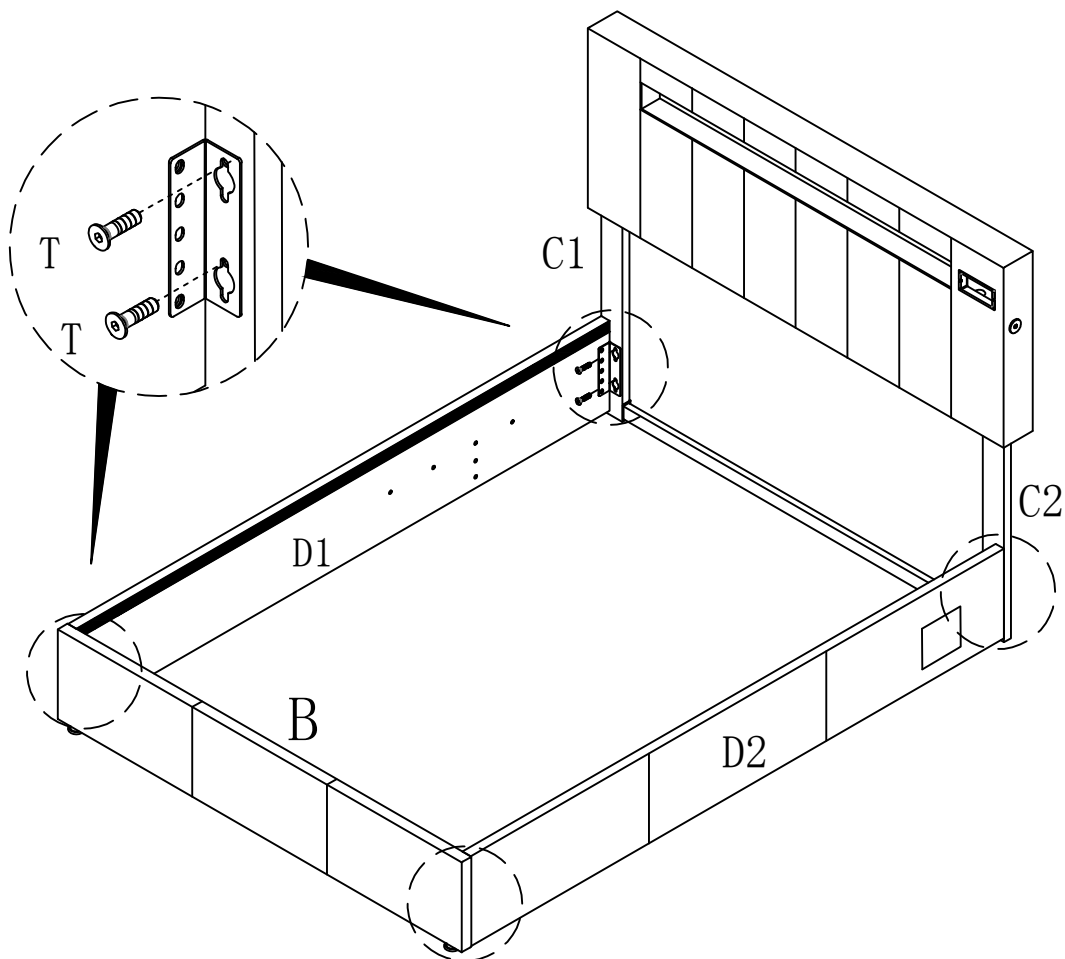

step8

R



6PCS

W



6PCS

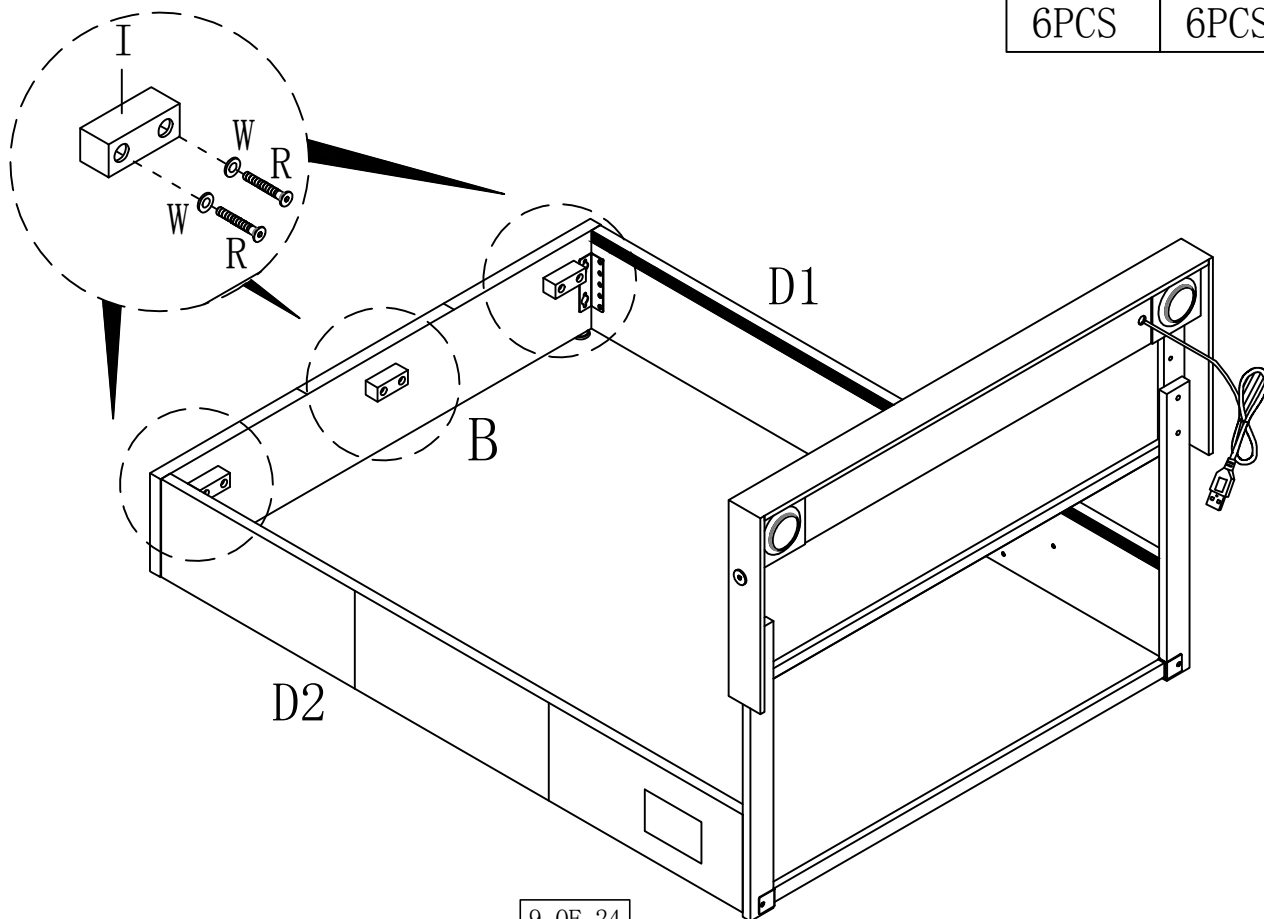

step9

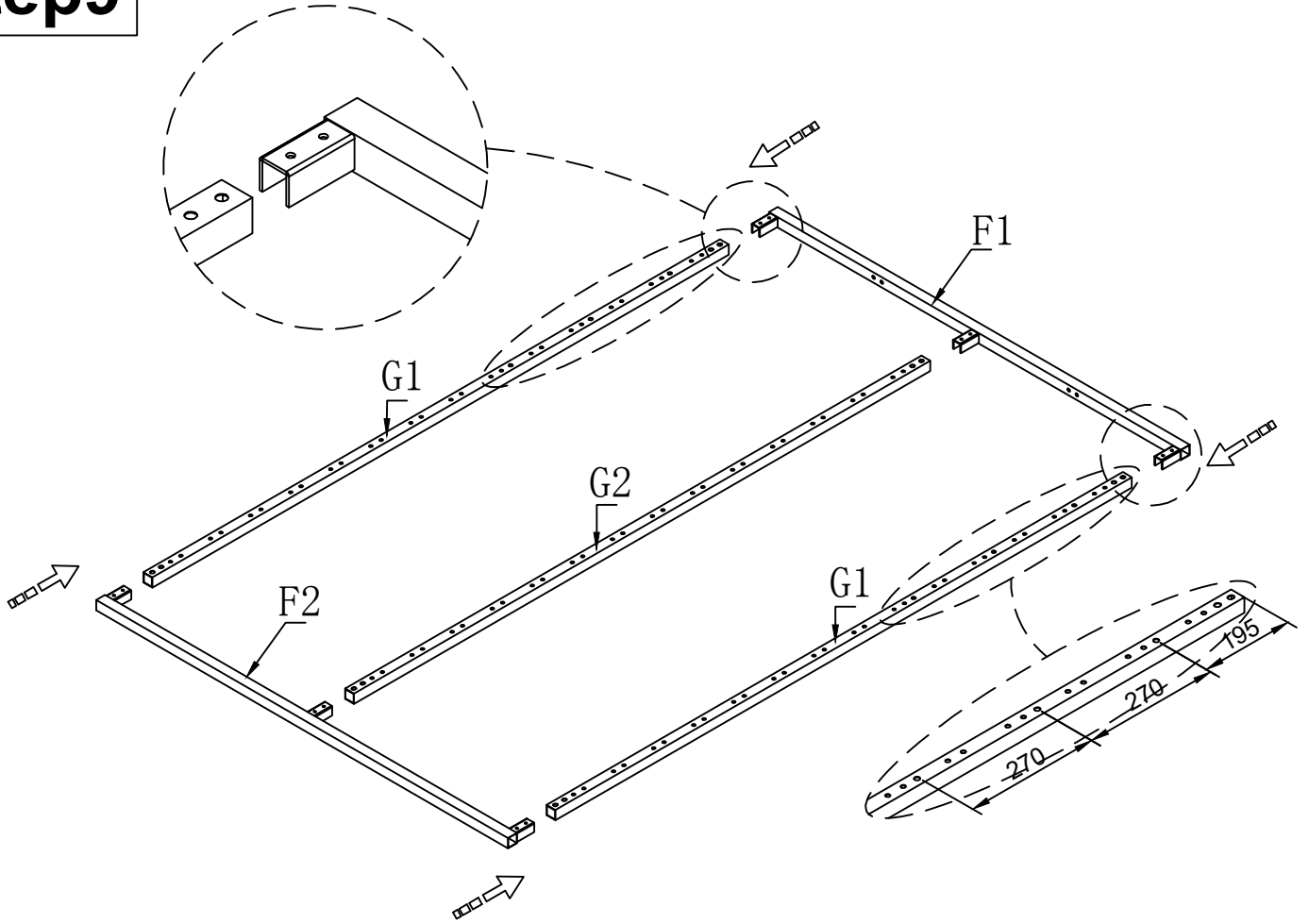

step10

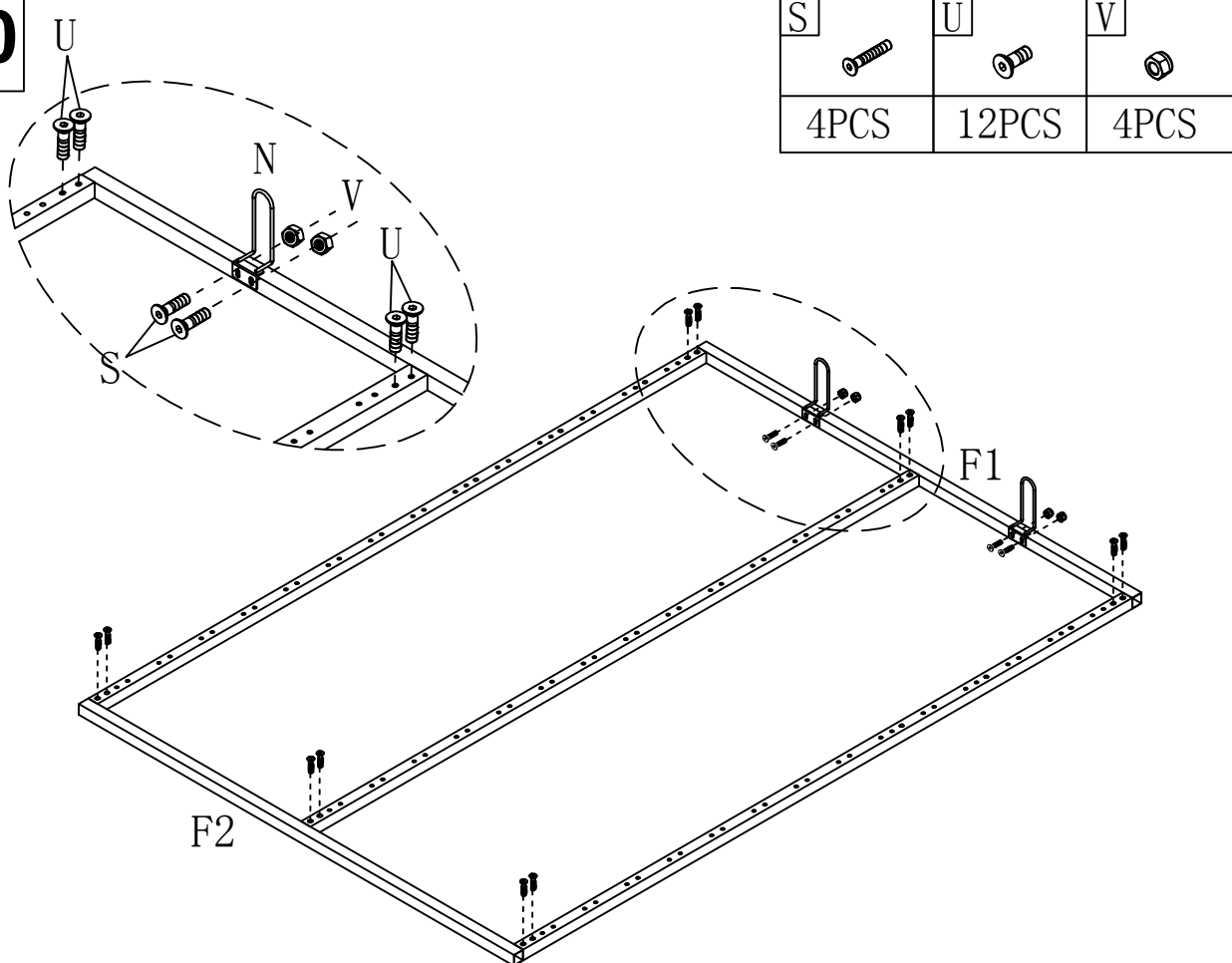

S	U	V
4PCS	12PCS	4PCS

step11

T



8PCS

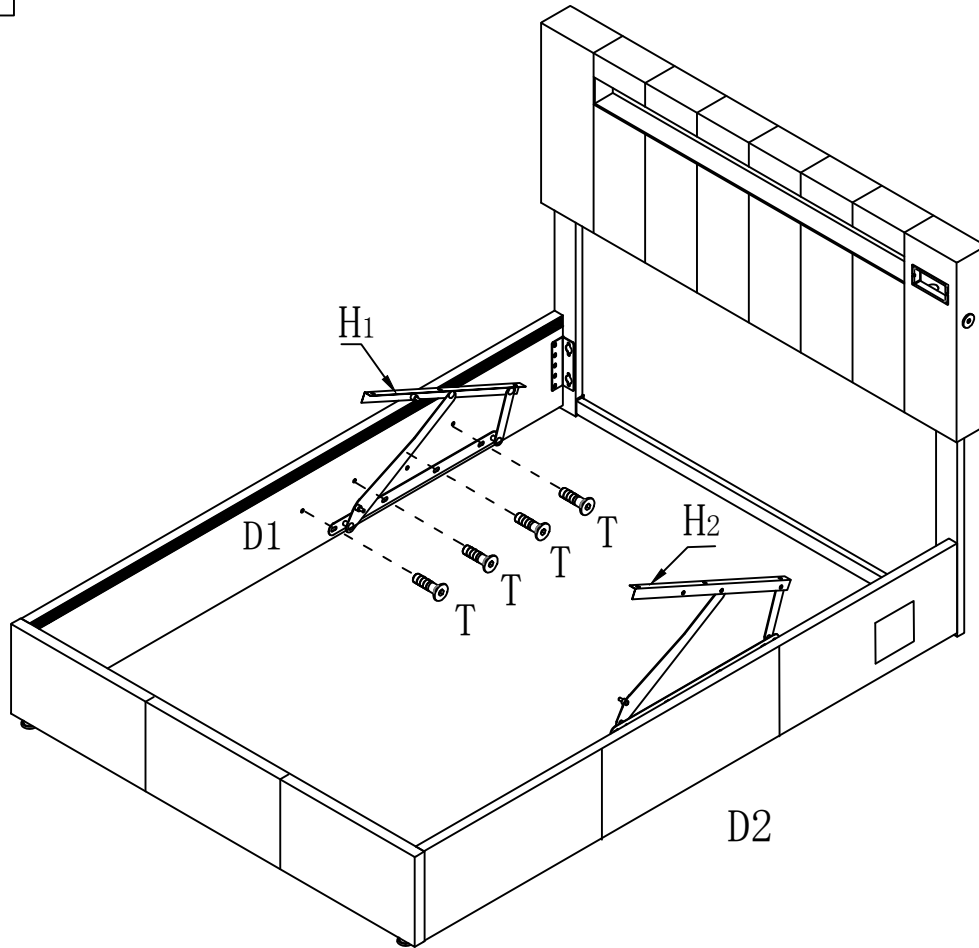

step12



S

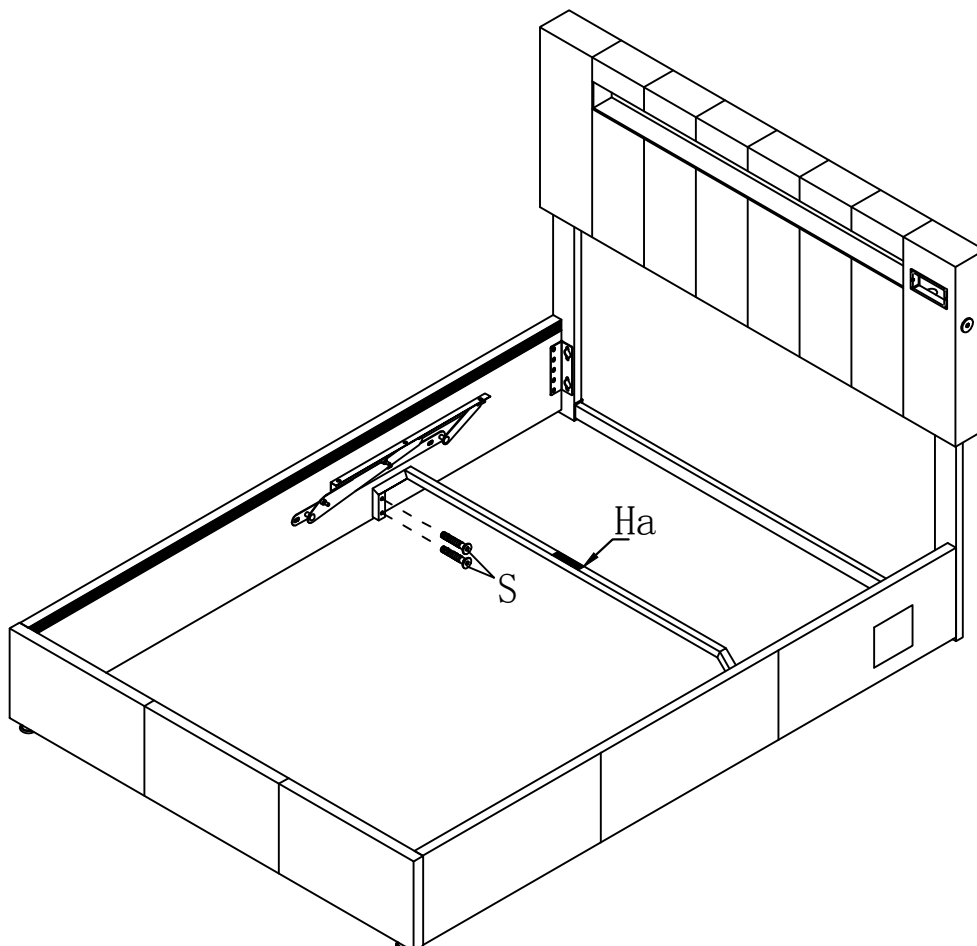

4PCS



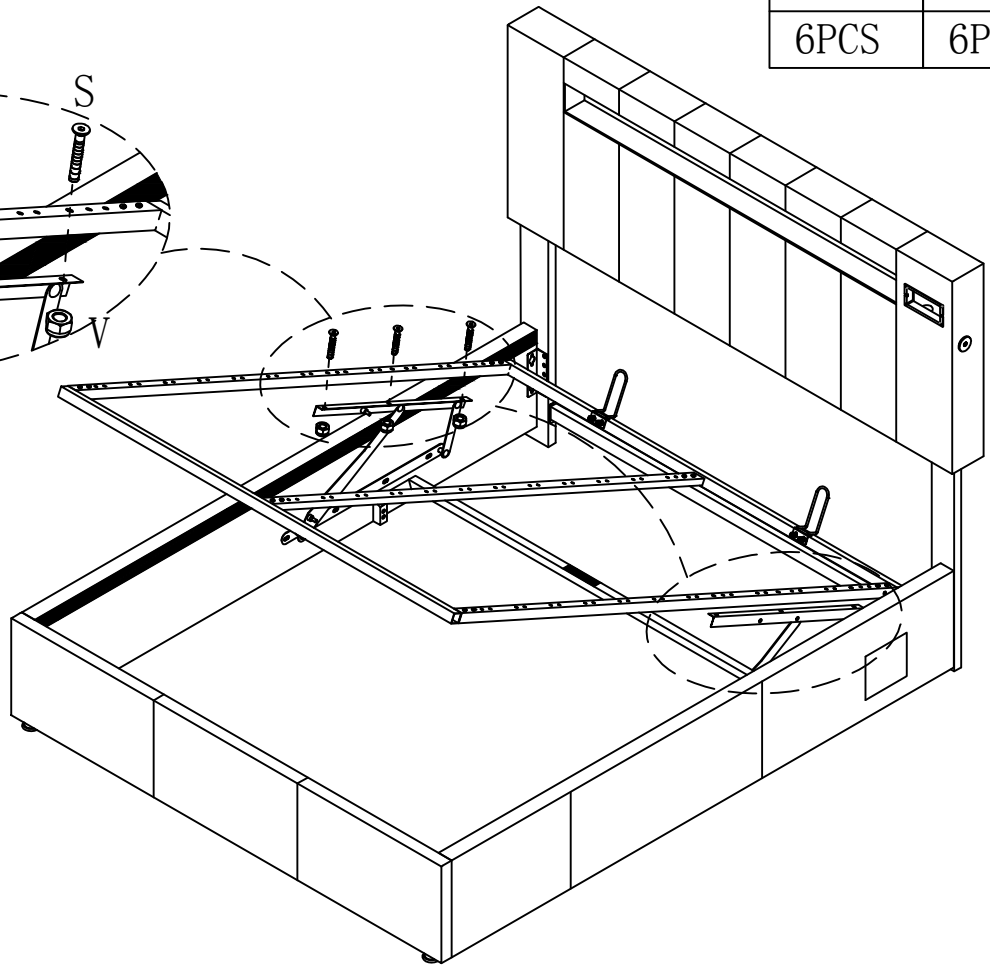
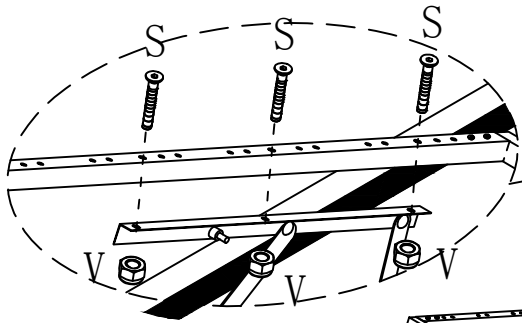

step13

S	V
	
6PCS	6PCS



step14

N1	V
	
2PCS	4PCS

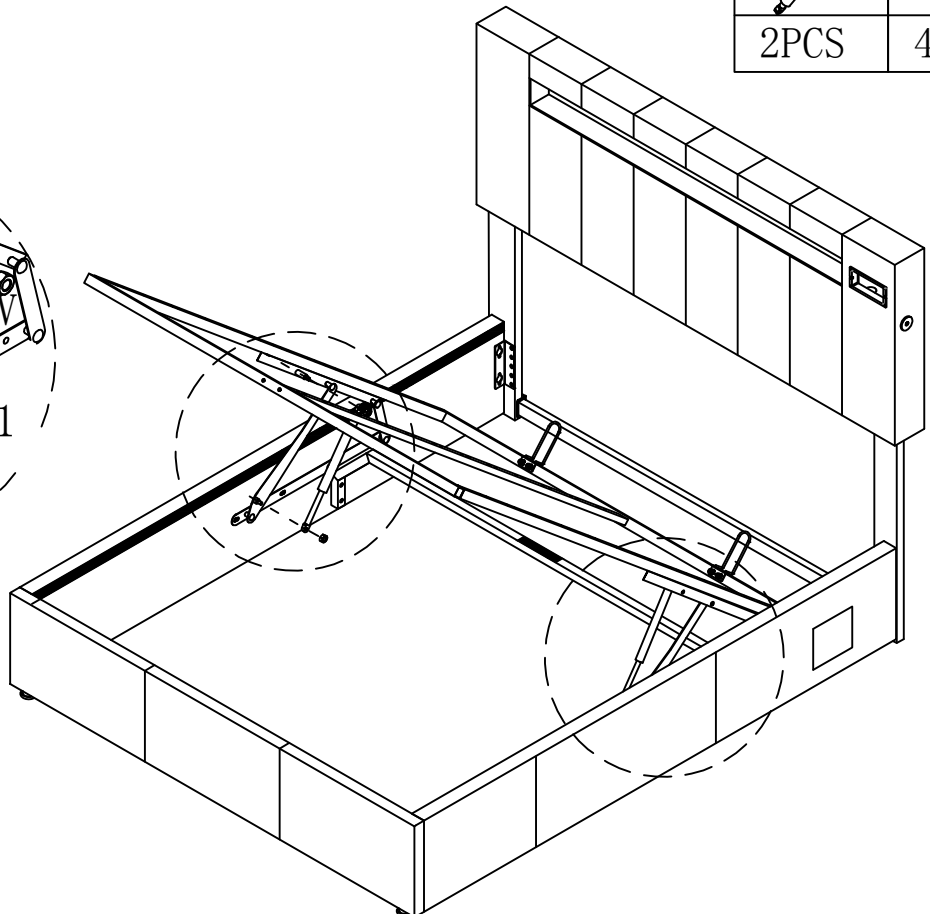
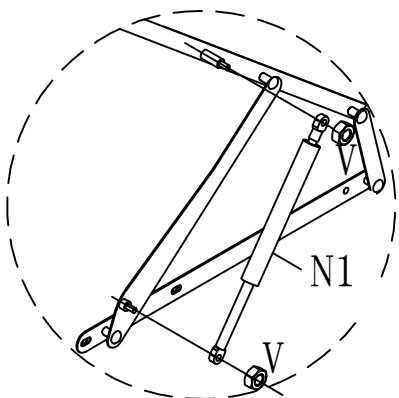

step15

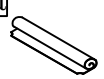
Aa

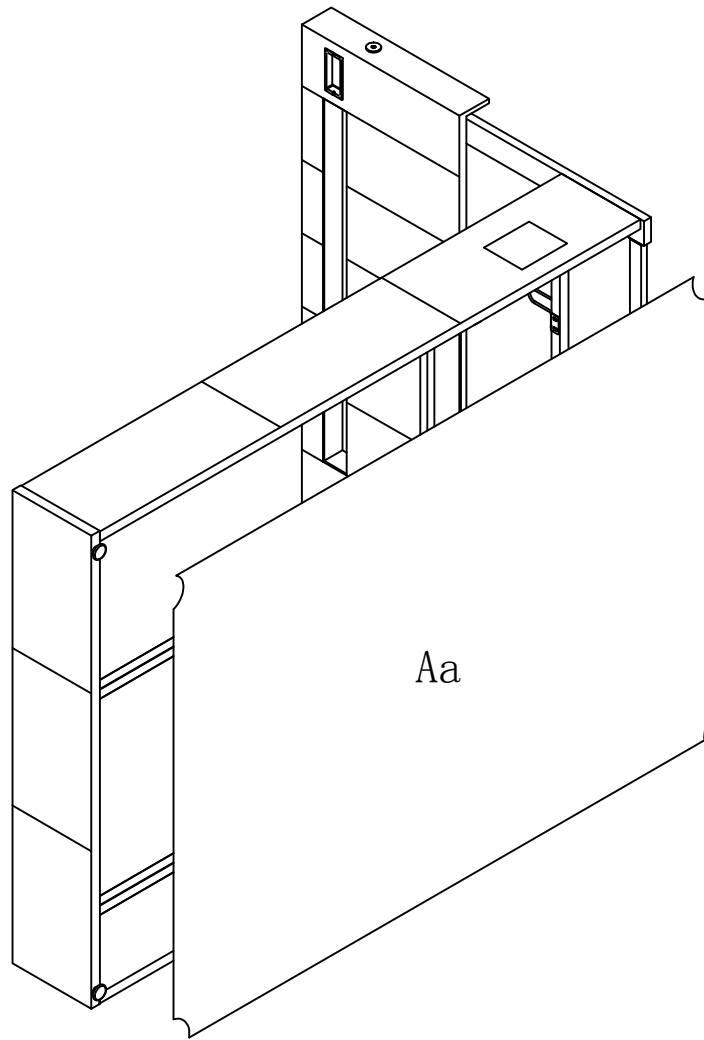
1PC

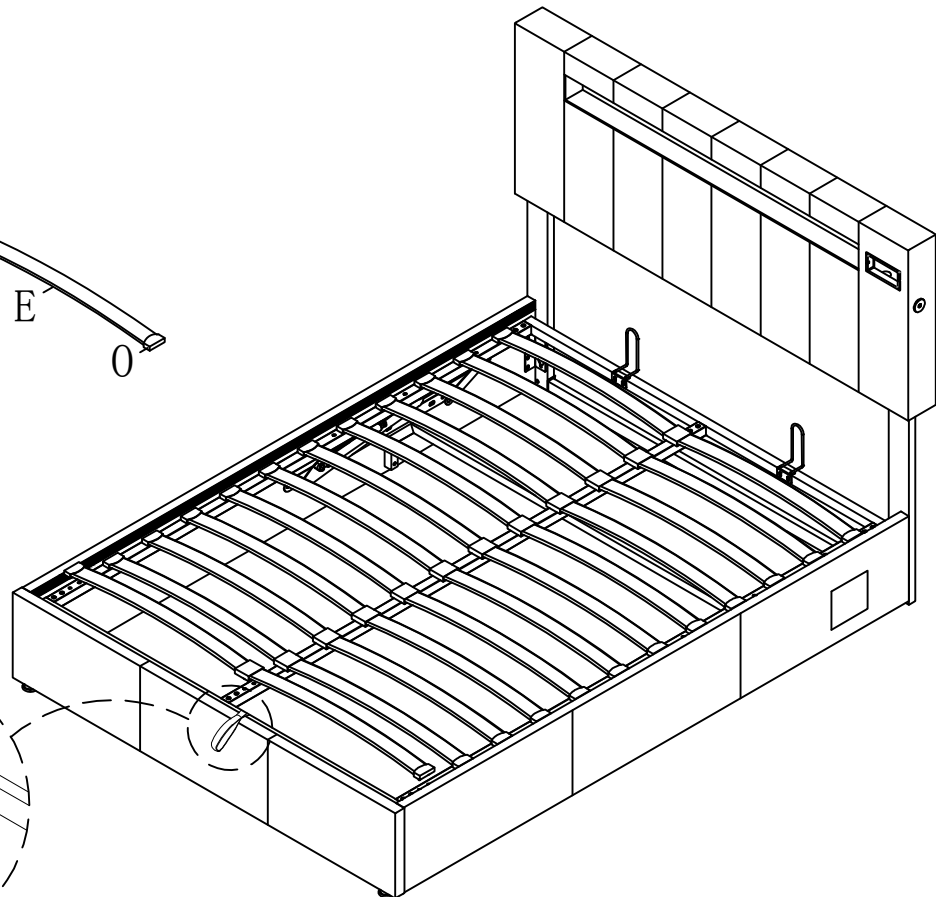
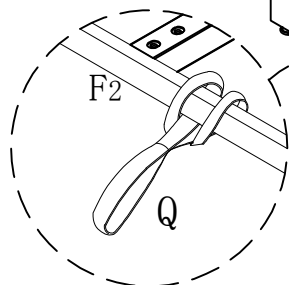
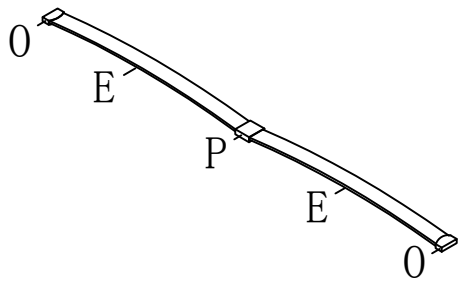

step16



step17

K1
1PC

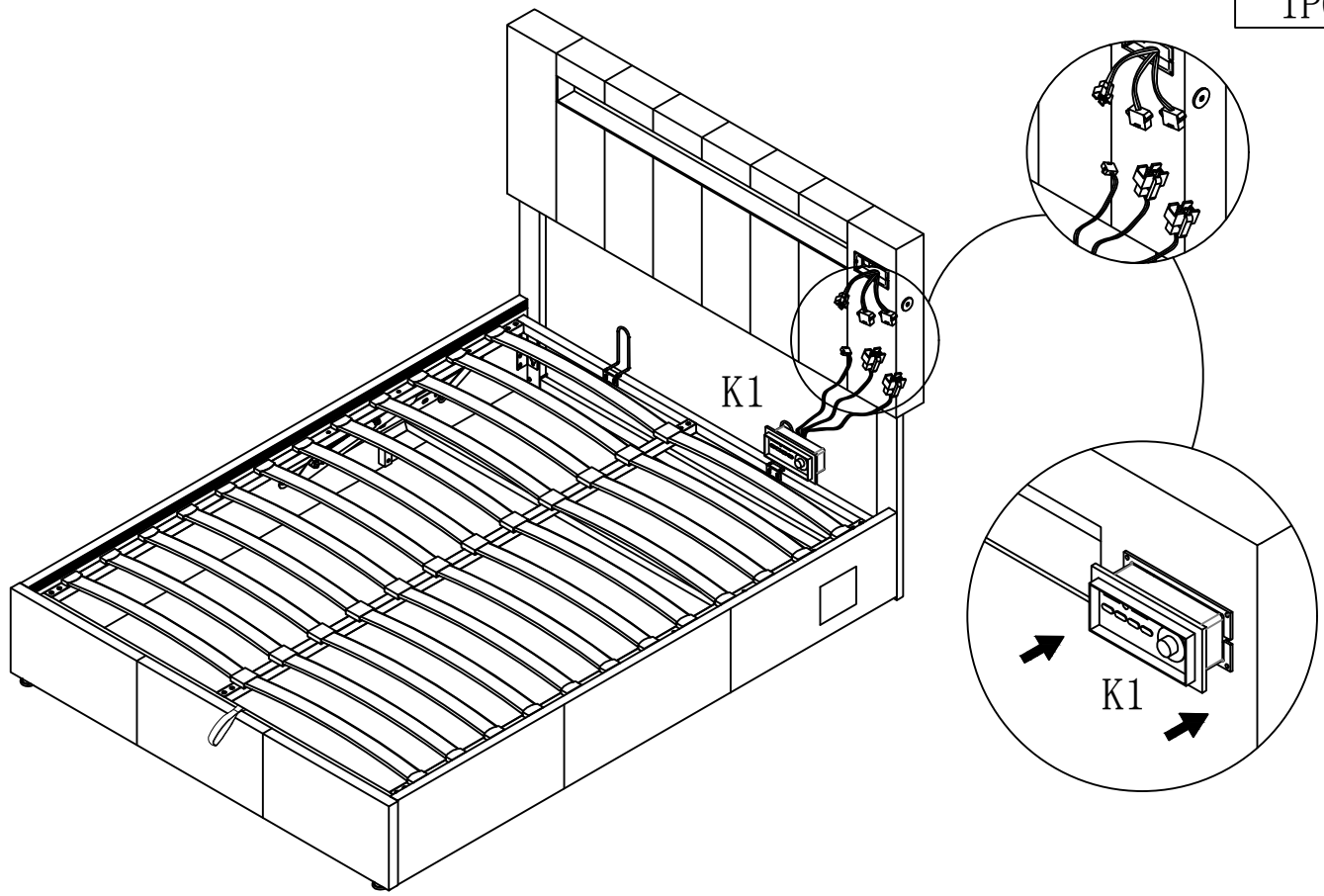

step18

K2
1PC

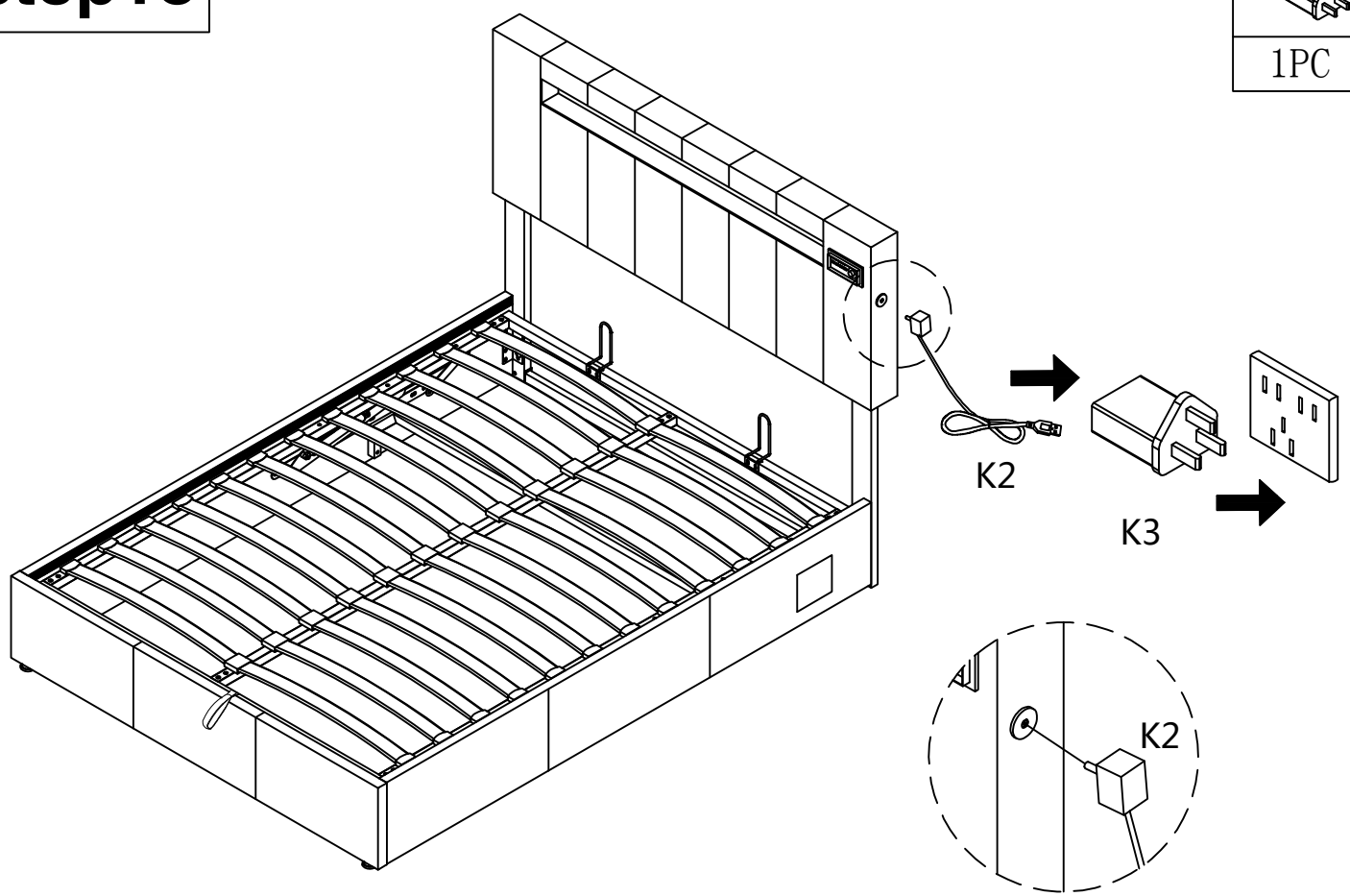

step19

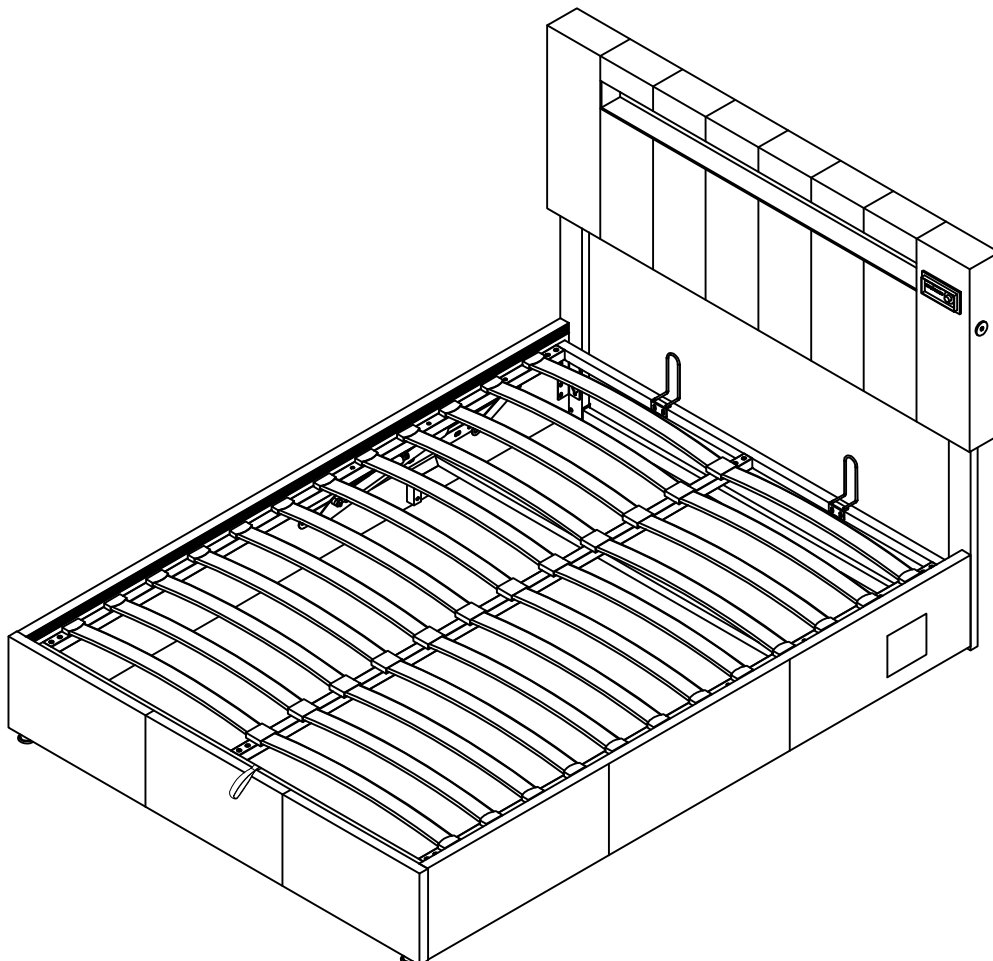
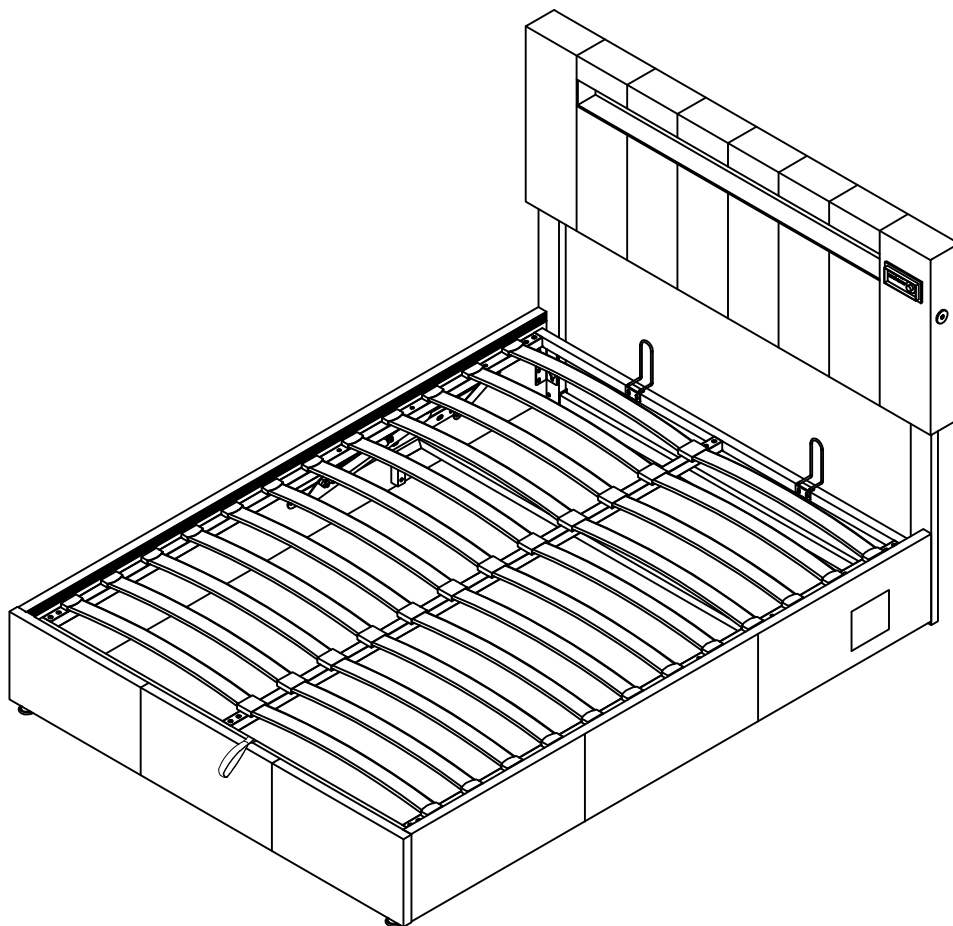

IMPORTANT NOTICE

OTTOMAN OPERATING INSTRUCTIONS

Once your bed frame is completely assembled, the slat unit will not operate correctly unless a mattress is placed on the slat frame. Position the mattress on the slat frame whilst it is in the closed position.

PLEASE NOTE It -takes a lot of force to make the initial movement of the ottoman. This is a design feature of the product so that it does not fall shut -the nearer to being closed the ottoman is, the easier it is to move. When the ottoman is almost shut, it will close completely under its own weight.

When lowering the slat unit for the first time, take care to make sure it does not rub unevenly on the inside face of the side rails. If it does, the bed has been assembled slightly out of square. This can be rectified by moving the foot end of the bed slightly to the left or right whilst leaving the head end stationary.

PISTONS

The pistons used in the construction of this product are extremely strong and cannot be operated by hand when taken off the ottoman. All pistons are tested for correct pressure and operation before being attached to the slat unit. Initially it might appear that the pistons are very stiff when opening and closing the ottoman.

THIS IS PERFECTLY NORMAL

When fully assembled and the mattress is in position, please raise and lower the ottoman 4/5 times to ensure the gas piston are fully lubricated.

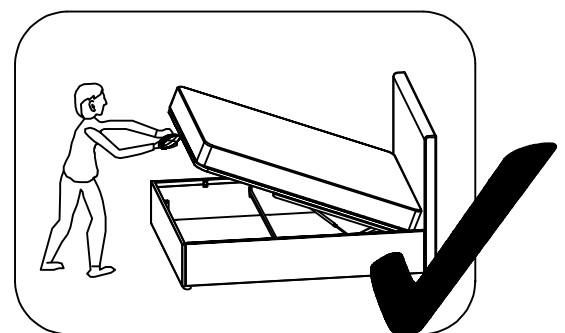
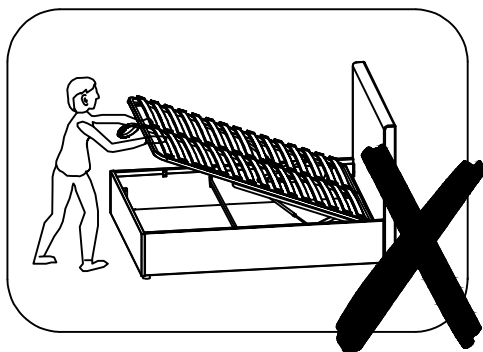

Shenzhen ZKT Technology Co., Ltd.
1/F, No. 101, Building B, No. 6, Tangwei Community Industrial Avenue,
Fuhai Street, Bao'an District, Shenzhen, China



Certificate of Compliance

Certificate Number: ZKT-2405094943C

Certificate's Holder : Shenzhen Pinchengxin Technology Co., Ltd
3rd Floor, 8th Building Yuanling Industrial Zone, No. 39
Yuanlingcun Road, Shiyuan Street, Bao'an District,
Shenzhen

Manufacturer : Shenzhen Pinchengxin Technology Co., Ltd
3rd Floor, 8th Building Yuanling Industrial Zone, No. 39
Yuanlingcun Road, Shiyuan Street, Bao'an District,
Shenzhen

Trade Mark : N/A

Product : 5050 RGB LED Strip Lights with Bluetooth App Controller
and 2.4G Remote

Model(s) : 5050 RGB LED Strip Lights

Test Standard : Art.3.1(a) Safety BS EN IEC 62368-1:2020+A11:2020

Art.3.1(a) Health BS EN IEC 62311:2020
BS EN 50665:2017

Art.3.1(b) EMC ETSI EN 301 489-1 V2.2.3 (2019-11)
ETSI EN 301 489-17 V3.2.4 (2020-09)

Art.3.2 Radio ETSI EN 300 328 V2.2.2 (2019-07)

This Attestation of Compliance is issued on a voluntary basis for electrical equipment below the voltage limits of Radio Equipment Directive (RED) SI 2017 No.1206. The essential requirements are fulfilled accordingly based on the technical specifications applicable at the time of issuance.



This Certificate of Conformity is based on single evaluation of the submitted sample(s) of the above mentioned product. It does not imply an assessment of the whole product and relevant Directives to be observed.

+86-400 000 9970 +86-755-22336688 zkt@zkt-lab.com www.zkt-lab.com

LotusLantern APP Manual

1. Software Overview

1.1 Overview

LotusLantern is a mobile APP to control LED strip by both IOS and Android phones.

The traditional control ways like infrared, 433MHz, 2.4GHz and others old wired ways will be replaced by mobile phone control way with convenient, powerful and scalable features.

Through this mobile APP , you can not only control the color, brightness and color temperature of the LED strips but also set up all kinds of fancy flash mode ; Also this APP can change the light of the LED strip according to the rhythm of the music. This APP can set and control several LED strips through Bluetooth and the operation is very simple, easy to learn and easy to use.

1.2 Features

- Adjust color LED strips with 60,000 colors to change color and brightness and adjust monochrome LED strips to change brightness and color temperature
- Play music or turn on a sound playback device, you can let the light change the color and brightness with the rhythm of music, the music rhythm beautiful
- Inside multiple setting mode for color change and control LED strips without mobile
- Long distance control with omni-directional antenna, and many-to-many group control mode
- Once the connection is successful, connect automatically next time

1.3 Performance

LotusLantern APP is easy for use as well as great compatible with all kinds of smart phones; After the actual test of hundreds of mobile phones verification, the compatibility is above 95% of mobile phones in the market. APP is small and convenient, it consumes less system resources, so the requirements of the mobile configuration are low. Control delay is small, the operation feels good, light control is smooth with people's visual sense.

2. Operating Environment

This APP program requires phones of system above Android 4.3 and iOS 8.0. Mobile phone configuration is not limited.

3. Instructions

Note: Android version and iOS version download and use the same method, here in the Android version as an example.

3.1 APP Download

Scan the QR code

iOS and Android systems can download the "LotusLantern" APP by scanning the QR code. Open the browser or other tools with "Scan QR code" function, scan the "LotusLantern" QR code as below:



3.2 App Operation

(1) Click on the LotusLantern APP icon, enter the APP page:

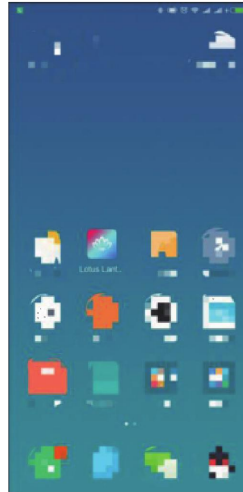

(2) After entering the APP interface, if Bluetooth is not enabled, "an application wants to enable the Bluetooth function of this device." Click [Allow]

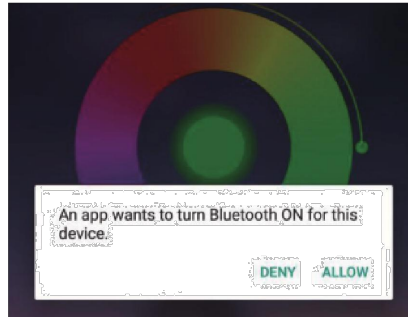

(3) switch to color and brightness interface:

Click to show the lamp list

Switch the color wheel

Display the RGB value
Click to manual adjustment view

Click to display setting view

Lamp switch button

Adjust the color

Click square icon to adjust the color

Click to shift the interface

(4) click to show the lamp list, view lamp list:

Bluetooth auto connect
after search for devices

Lamp list

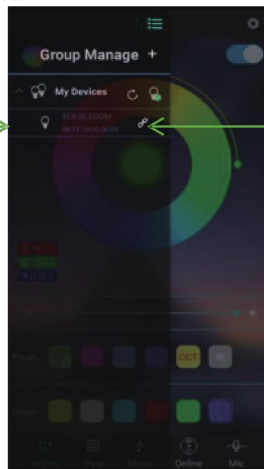

Status of device connection

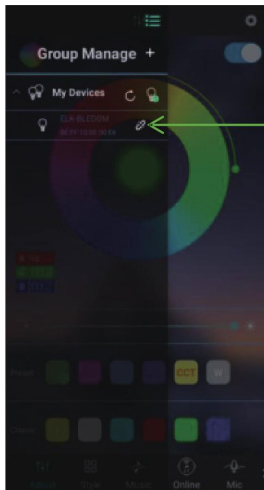

Status of device connection

(5) Click to RGB manual adjustment view:



(6) switch to the mode interface:

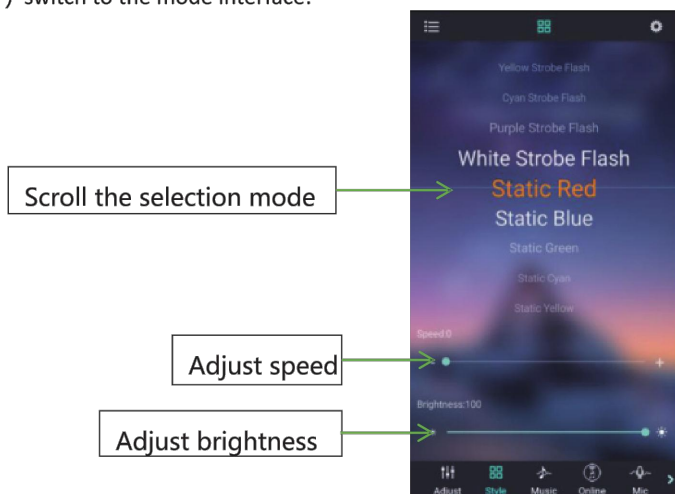

(7) switch to the music rhythm interface:

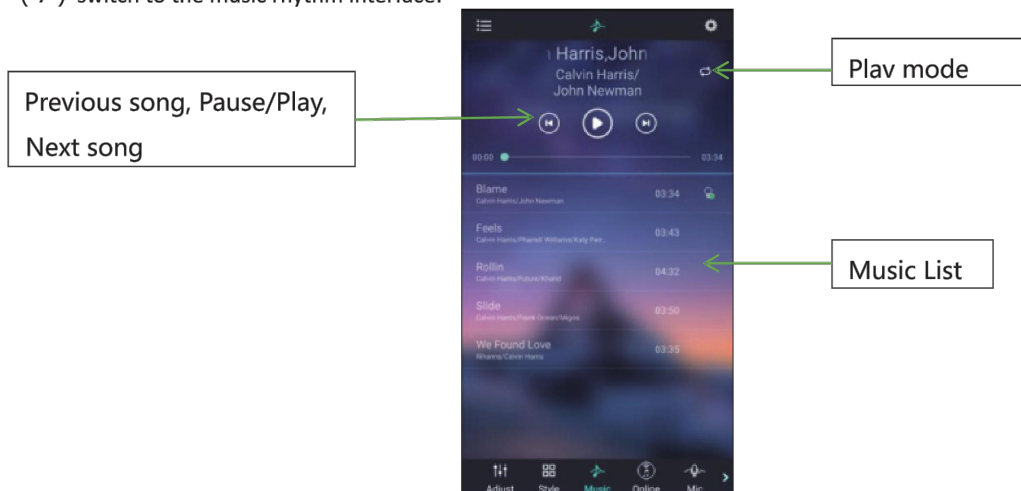

(8) Switch to the online music interface:

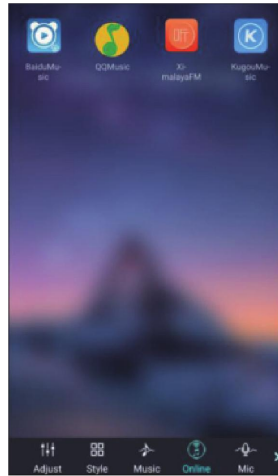

(9) Switch to the microphone rhythm interface:

Music rhythm through cell phone microphone

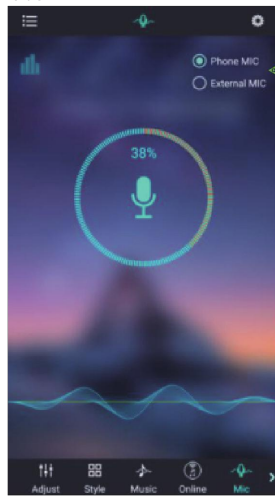

Switch phone microphone and external microphone

Music rhythm through the microphone on the product

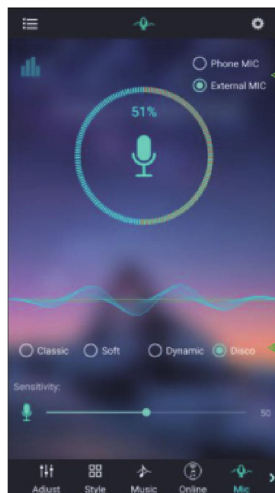

Switch phone microphone and external microphone

4-style rhythm

Change the sensitivity of MIC to match the sound

(10) Switch to the schedule interface:

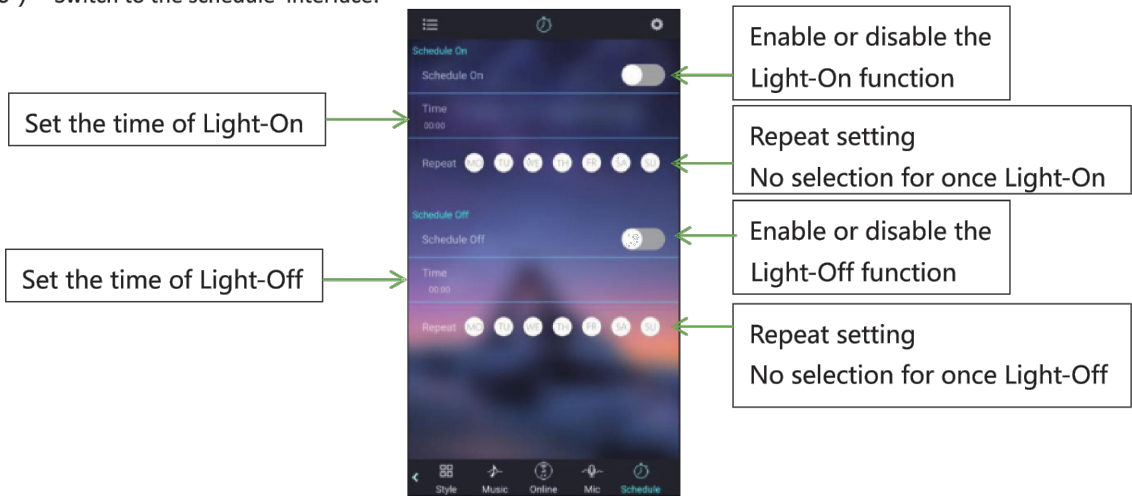

(11) Switch to the modify pin sequence interface:

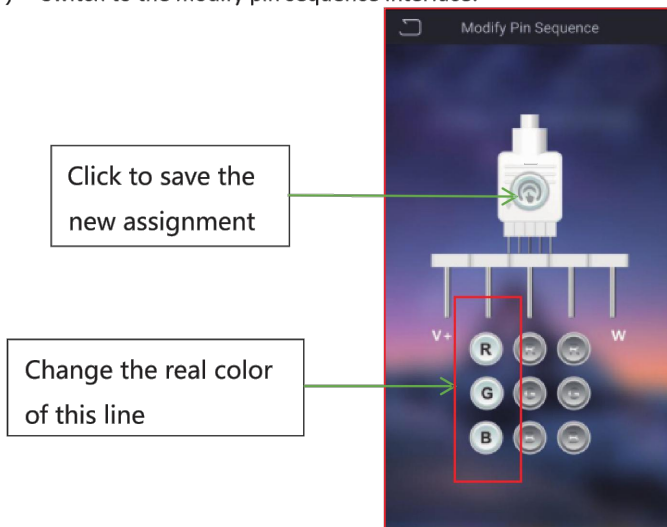

Technical parameters:

Working temperature: -20-60°C (-4 F°-140 F°)

Power supply voltage: DC5-24V

Output: 3 Loops

Static power consumption: <0.5W

Output current: <3A(each circuit)5V <30W 12V<108 24V<21 6W

UK Declaration of Conformity

in accordance with

Radio Equipment Regulations 2017(SI 2017/1206)**Certificate No.: SiCT2303030253C**

Applicant : Dongguan Juyou Industrial Co., Ltd
Room 202, Building 2, No. 4, Lindong SAN Road, Lincun, Tangxia Town,
Dongguan City, Guangdong Province

Manufacturer : Dongguan Juyou Industrial Co., Ltd
Room 202, Building 2, No. 4, Lindong SAN Road, Lincun, Tangxia Town,
Dongguan City, Guangdong Province

Product : Household Sofa Bluetooth Speaker

Trademark : N/A

Model : F-920, F-916, F-918

Standard(s):	Report No.:	
Article 3.1 (a)	BS EN EN IEC 62368-1:2020+A11:2020	SiCT2303030253S
	BS EN 62479:2010, BS EN 50556:2018	SiCT2303030253-1E
Article 3.1 (b)	ETSI EN 301 489-1 V2.2.3 (2019-11)	SiCT2303030253-2E
	ETSI EN 301 489-17 V3.2.4 (2020-09)	
	EN 55032:2015+A11:2020 EN 55035:2017+A11:2020	
Article 3.2	ETSI EN 300 328 V2.2.2 (2019-07)	SiCT2303030253-3E

The certificate of conformity is based on an evaluation of a sample of the above-mentioned product(s). The technical report is at the disposal of the applicant. This is to certify the tested sample that is in conformity with all provisions of UK Radio Equipment Regulations (SI 2017/1206) of 2017. It is only valid in connection with the test report number as listed.

Any use of the SiCT name or its marks for the sale of the tested product must first be approved in writing by SiCT. The test results referenced in this Verification are relevant only to the sample tested.



Authorized Signer: _____

Andy Wang/Manager

Date: Mar. 07, 2023**Shenzhen SiCT Technology Co., Ltd.**

202, Building 3, No.111 Huanguan Middle Road, Songyuanxia
Community, Guanhu Street, Longhua District, Shenzhen, Guangdong, China
E-mail: info@sict-lab.com.cn Http:// www.sict-lab.com.cn