

ASSEMBLY INSTRUCTIONS



TV STAND

ASSEMBLY INSTRUCTIONS

ASSEMBLY TIPS:

1. Remove hardware from box and sort by size.
2. Please check to see that all hardware and parts are present prior to start of assembly.
3. Please follow attached instructions in the same sequence as numbered to assure fast & easy assembly.



WARNING!

1. Don't attempt to repair or modify parts that are broken or defective. Please contact the store immediately.
2. This product is for home use only and not intended for commercial establishments.



ASSEMBLY TIME

60 MINUTES

MAX TV SIZE: 85"



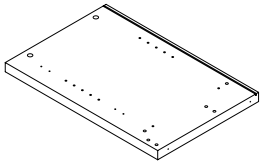
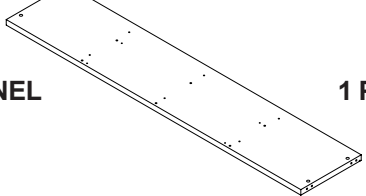
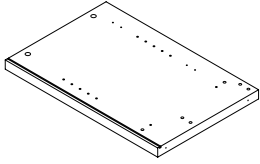
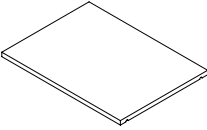
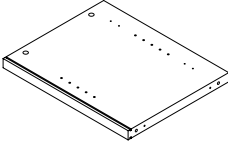
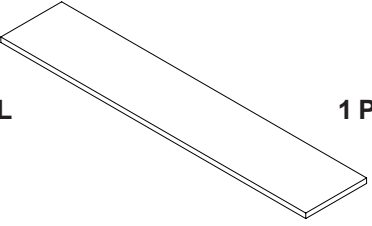
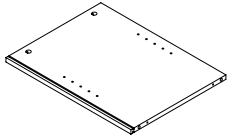
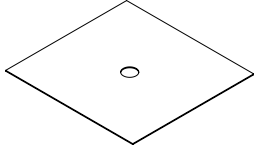
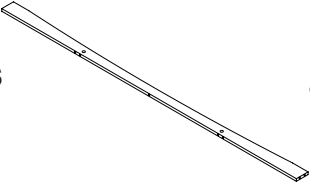
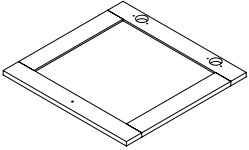
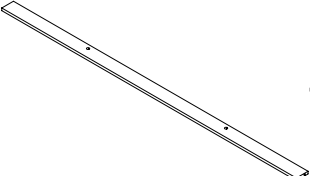



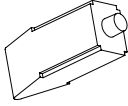
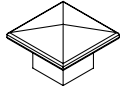
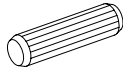

PARTS IDENTIFICATION

A	LEFT SIDE PANEL		1 PC	G	BOTTOM PANEL		1 PC
B	RIGHT SIDE PANEL		1 PC	H	ADJUSTABLE SHELF		4 PCS
C	MIDDLE DIVIDER PANEL		1 PC	I	TOP PANEL		1 PC
D	DIVIDER PANEL		2 PCS	J	BACK PANEL		4 PCS
E	FRONT CROSS BRACE		1 PC	K	DOOR		4 PCS
F	BACK CROSS BRACE		1 PC				

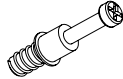
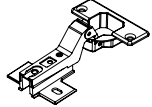
NOTE:

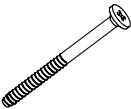
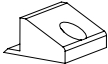
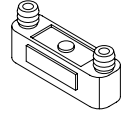
Phillips head screw driver is required in the assembly process; however, manufacturer does not provide this item.

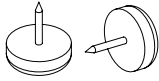
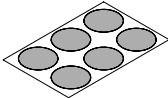
HARDWARE IDENTIFICATION

Z							
NO	DESCRIPTION	FIGURE	Q'TY	NO	DESCRIPTION	FIGURE	Q'TY
1	GLUE 40g		1 PC	9	HANDLE BLK		4 PCS
2	WOODEN DOWEL Ø8x30mm		34 PCS	10	HANDLE BOLT BLK		4 PCS
3	CAM BOLT Ø7x35.5mm SR		18 PCS	11	HINGE Ø35mm SR		8 PCS
4	CAM LOCK Ø15x12mm SR		18 PCS	12	HINGE SCREW Ø4x15mm SR		32 PCS
5	BOLT Ø9.5x55mm SR		6 PCS	13	FIXER		6 PCS
6	DOOR CATCH		4 PCS	14	FIXER SCREW Ø3x19mm SR		6 PCS
7	PLASTIC FEET Ø15mm		6 PCS	15	STICKER Ø20mm		3 PCS
8	PIN FOR ADJUSTABLE SHELF Ø4.9x15mm SR		16 PCS				

Z11 not included in blister packaging.

NOTE:

Phillips head screw driver is required in the assembly process; however, manufacturer does not provide this item.

STEP 1

2
x 30

3
x 4

7
x 6

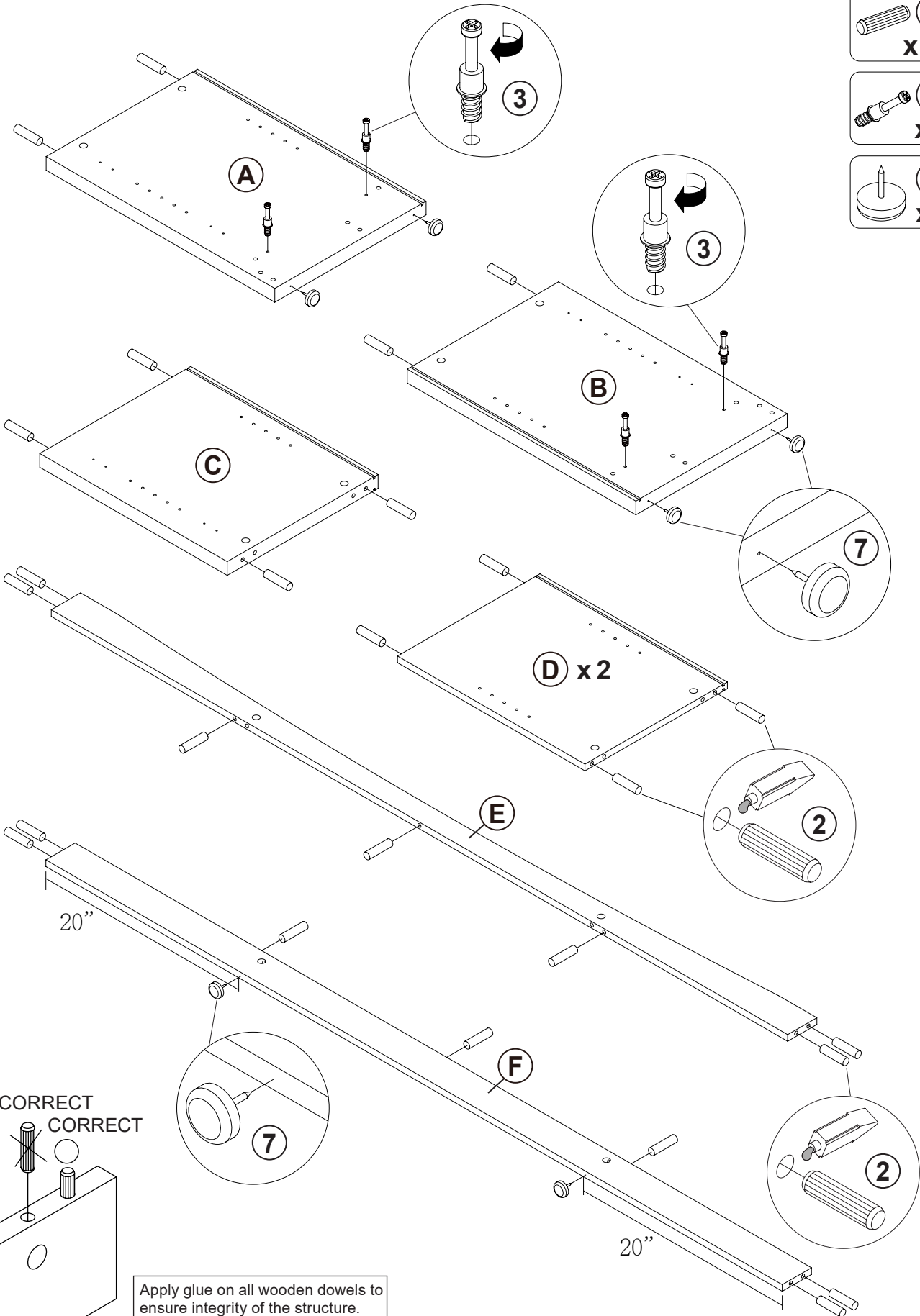

INCORRECT
CORRECT

Apply glue on all wooden dowels to ensure integrity of the structure.

STEP 2

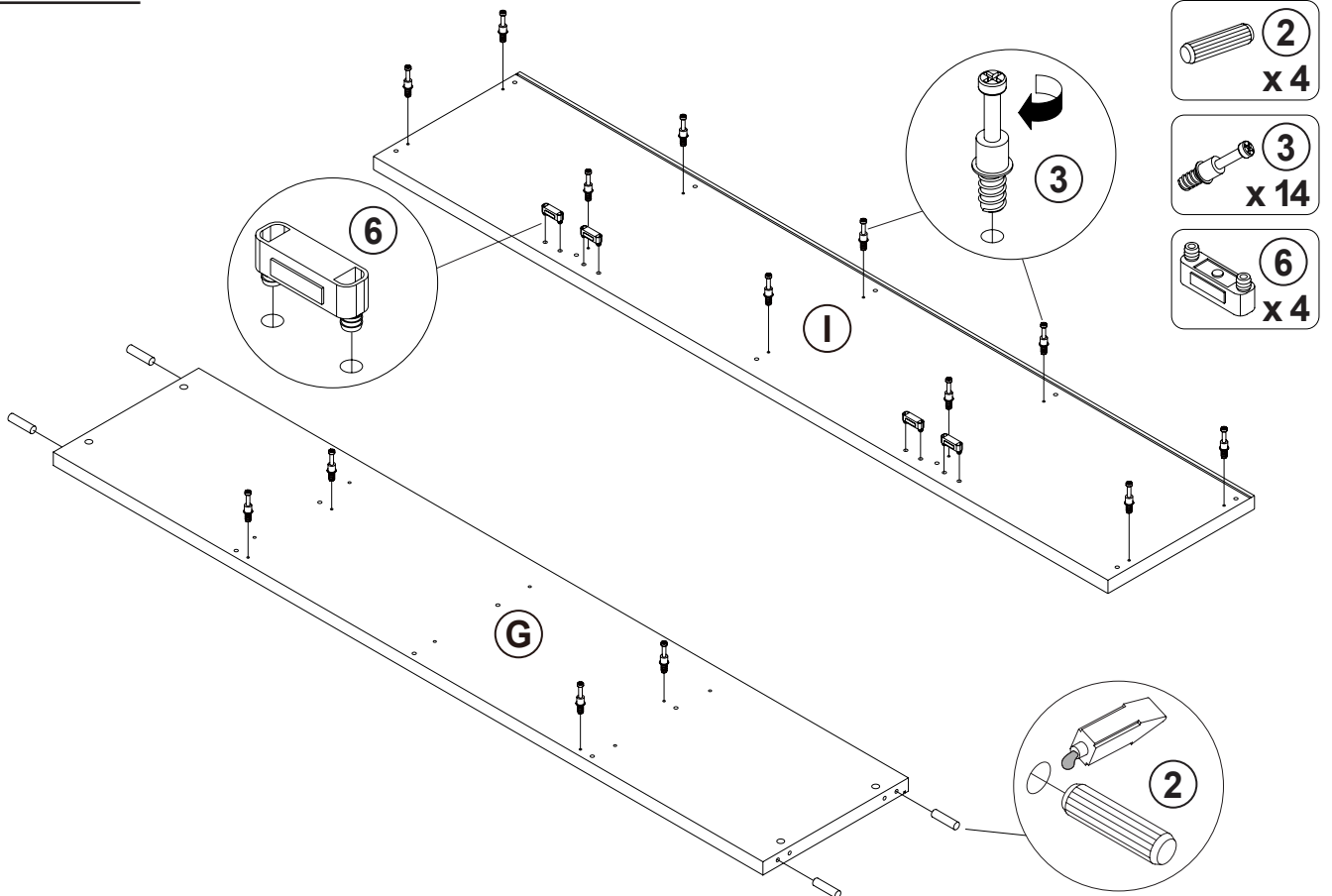

STEP 3

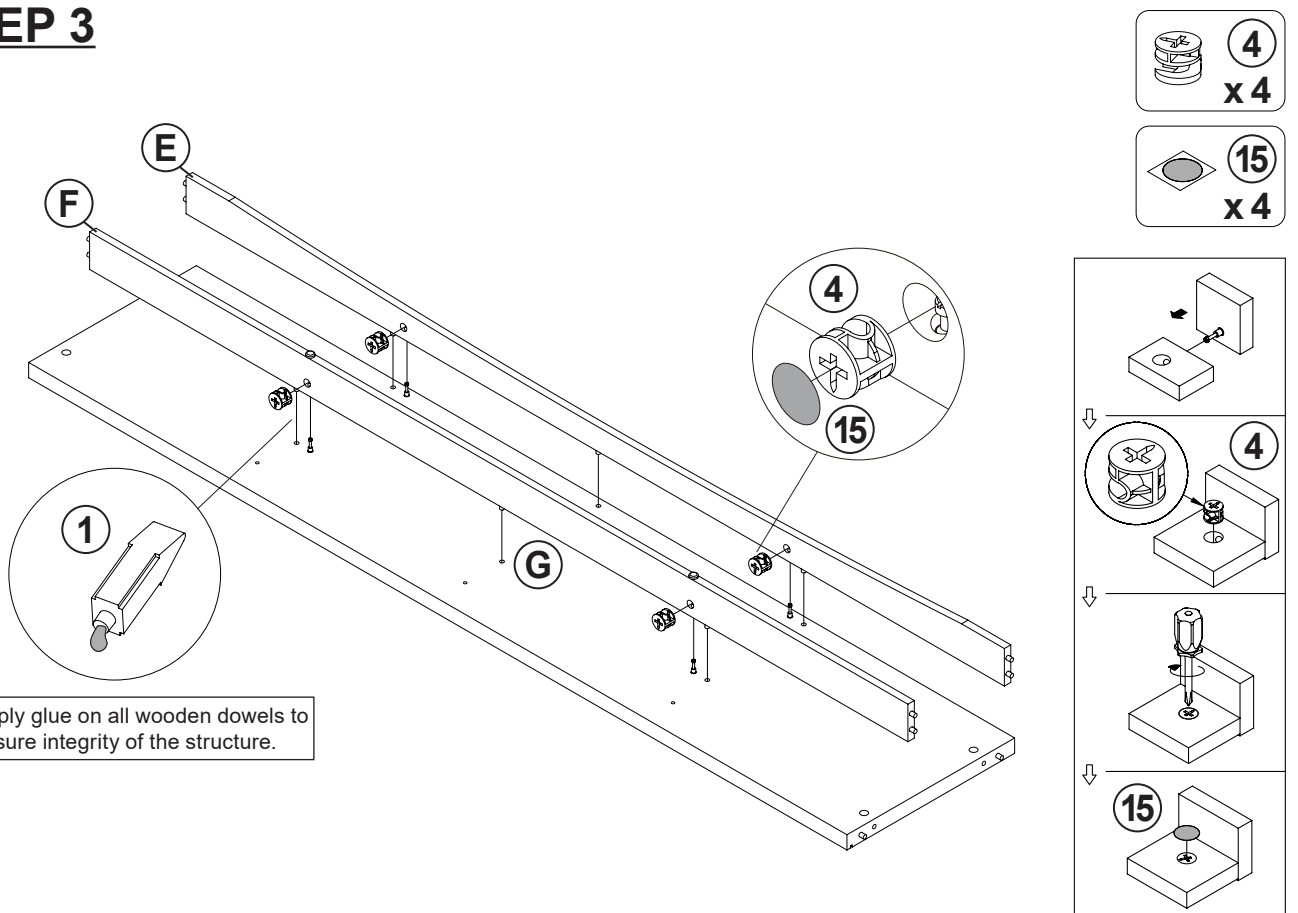

STEP 4

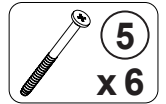
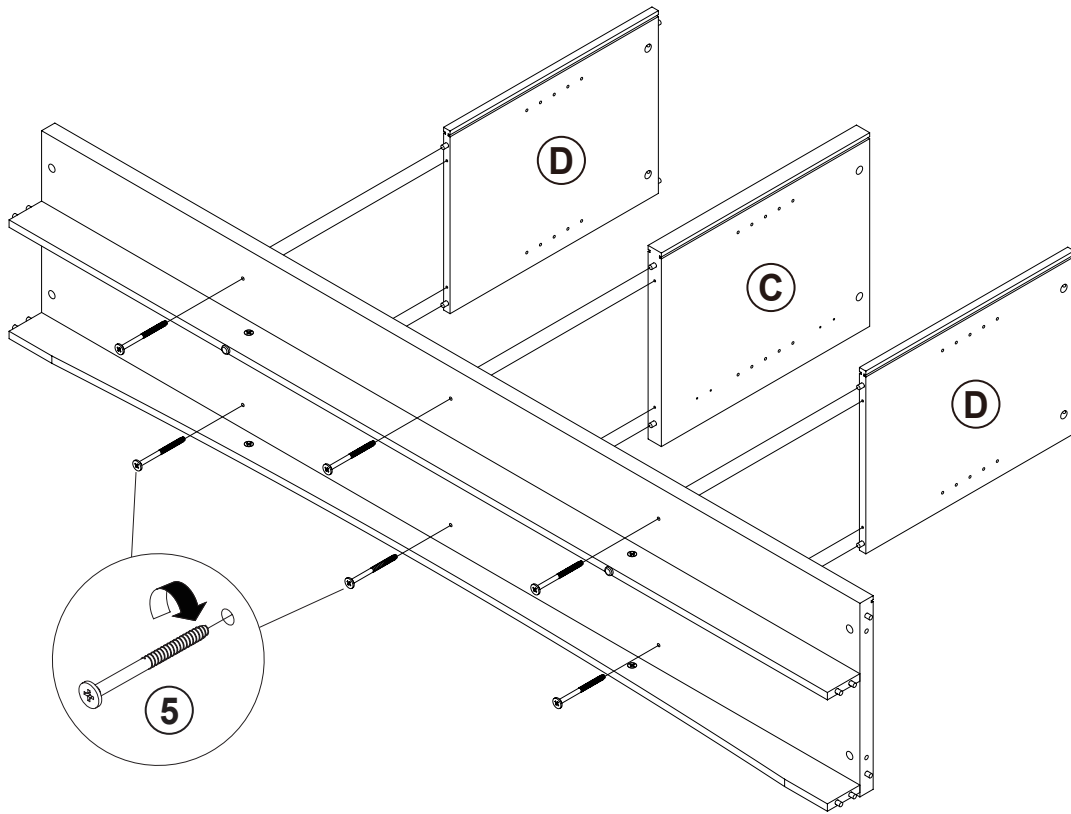

STEP 5

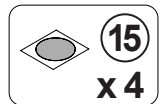
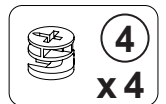
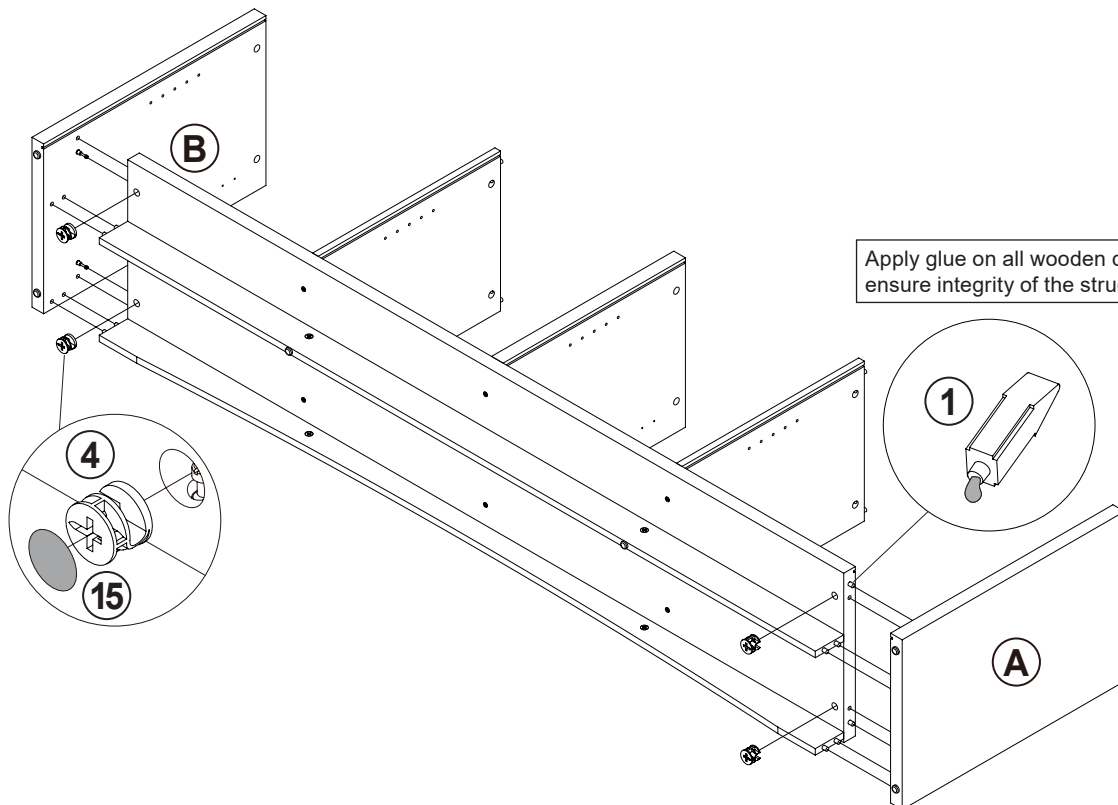

Apply glue on all wooden dowels to ensure integrity of the structure.

STEP 6

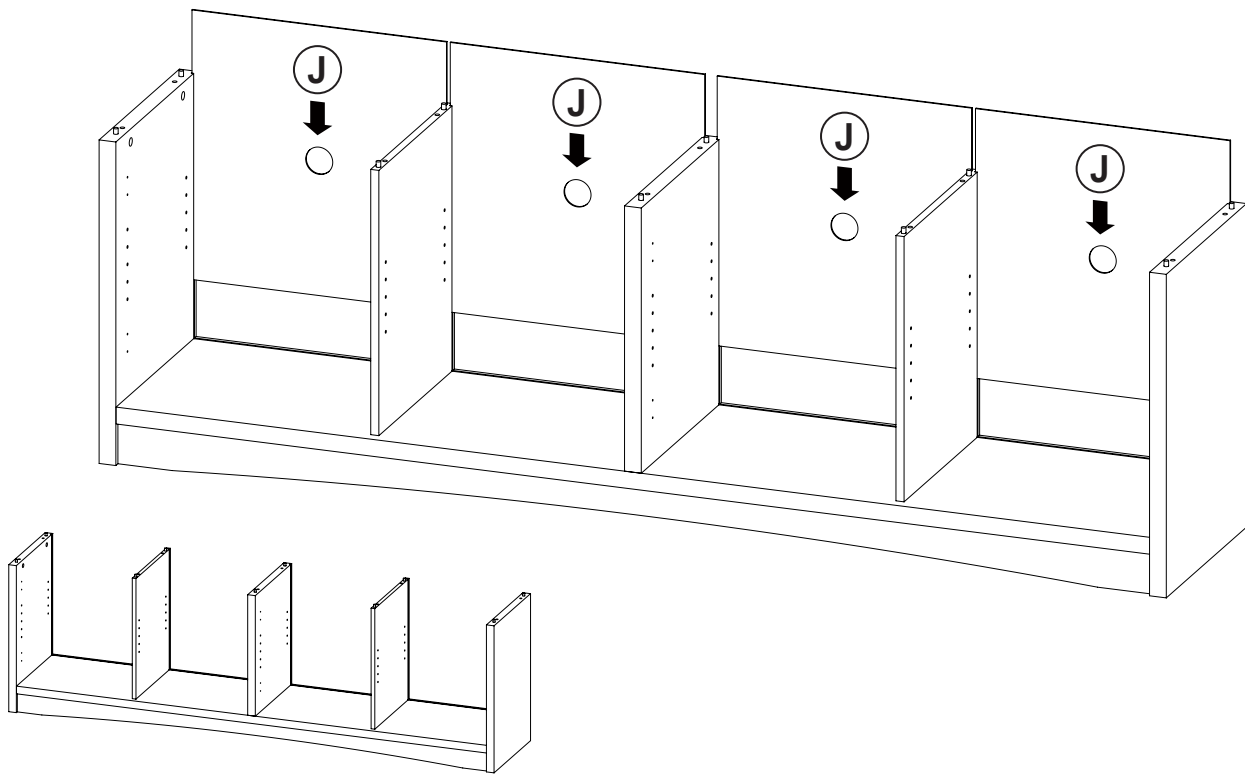

STEP 7

Apply glue on all wooden dowels to ensure integrity of the structure.

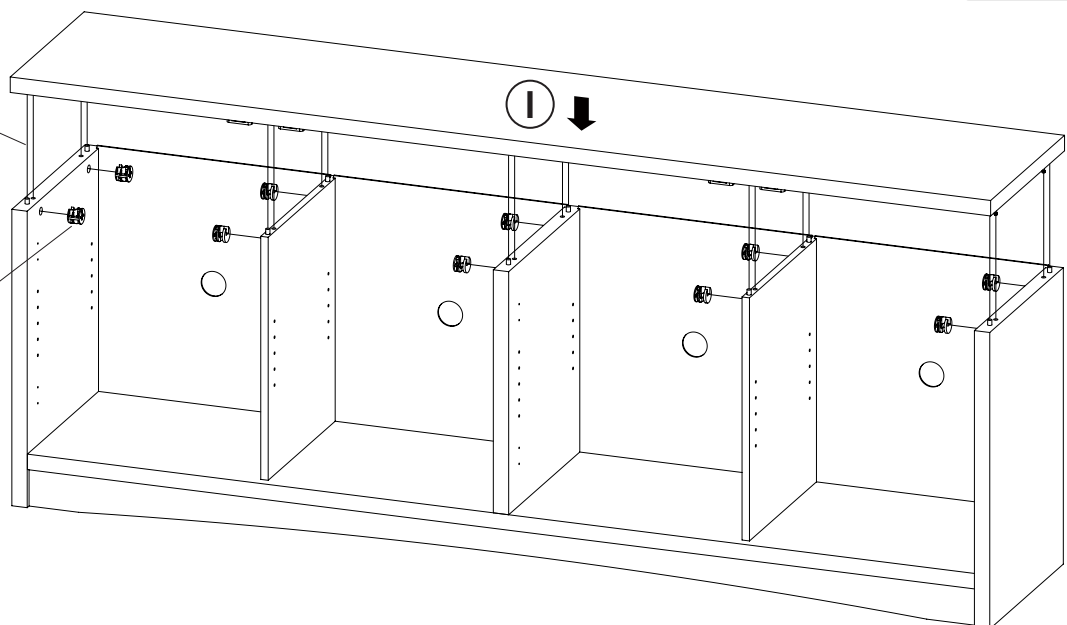
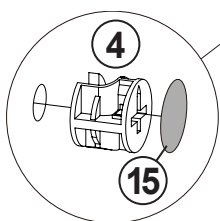
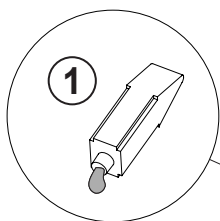
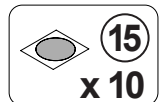
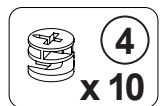

STEP 8

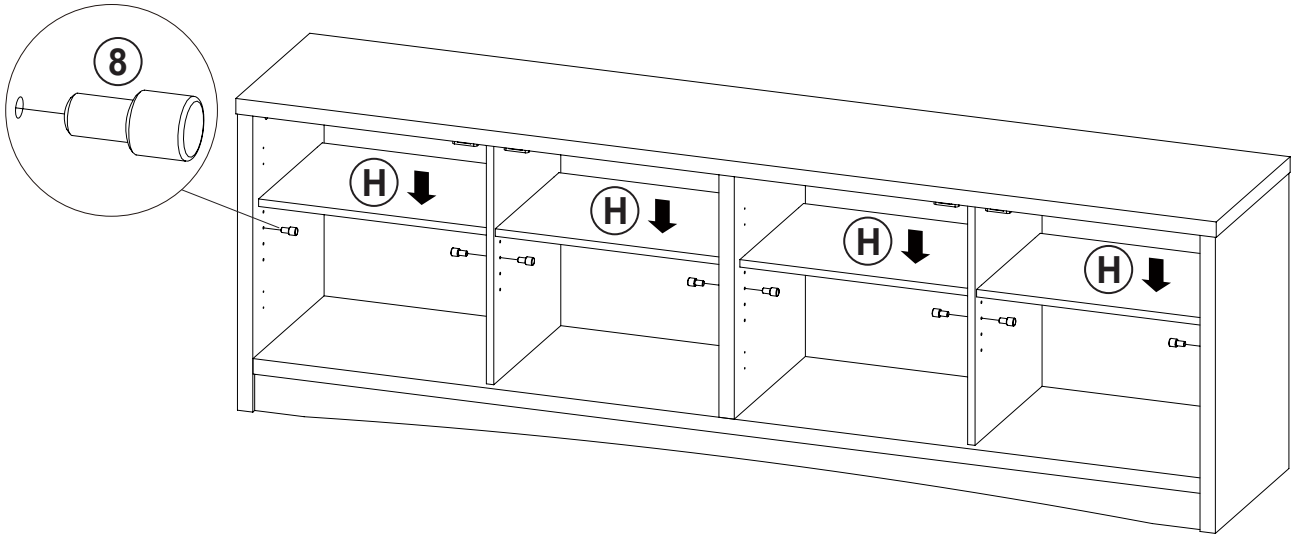
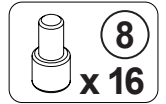

STEP 9

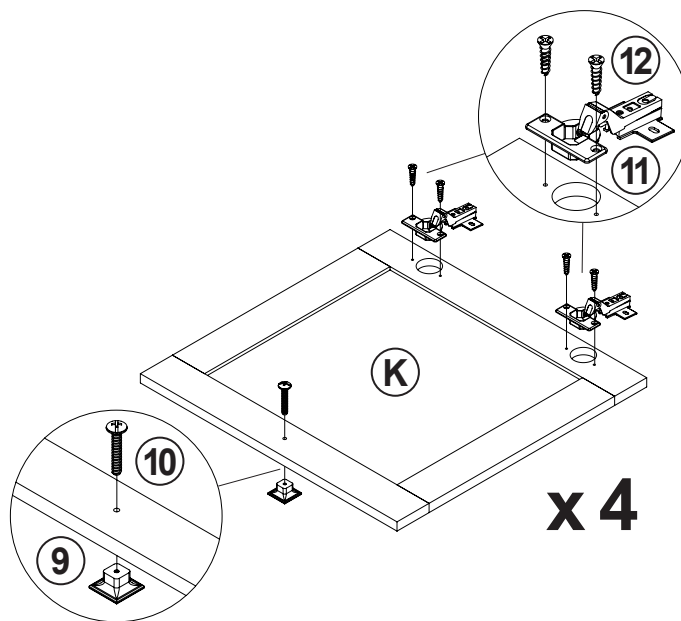
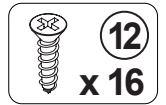
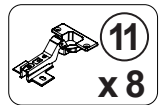
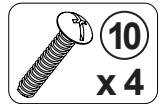
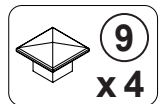

STEP 10

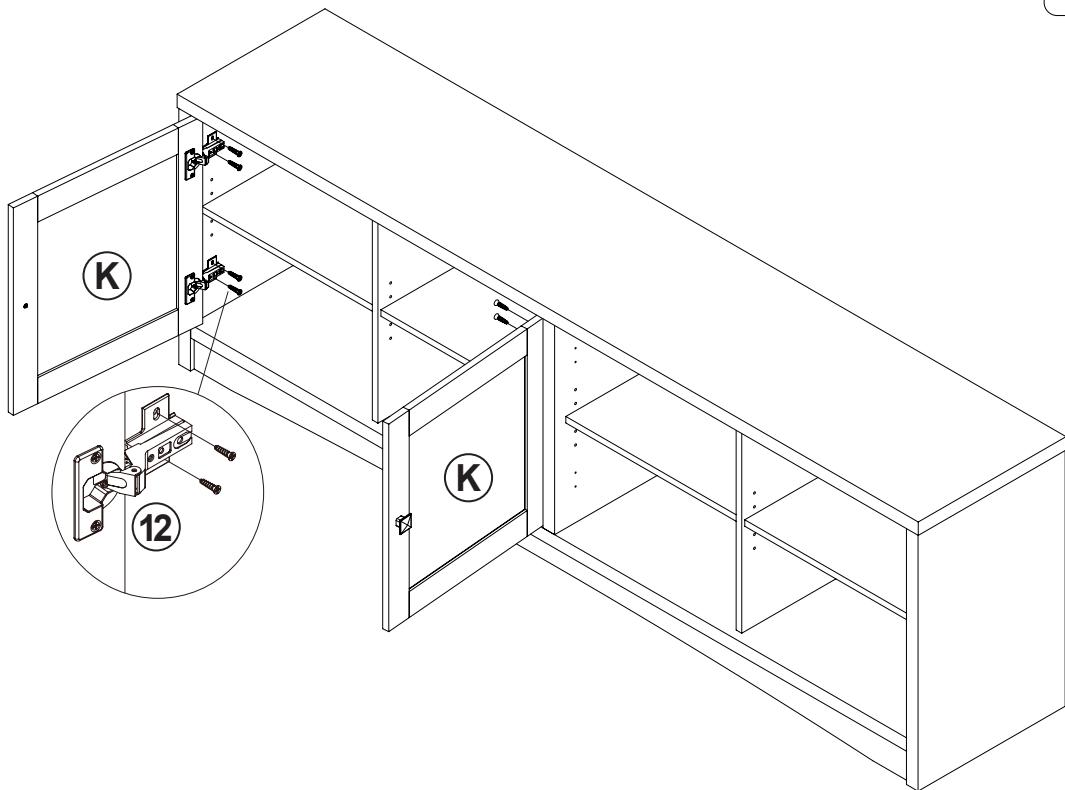
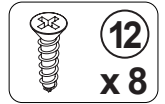

STEP 11

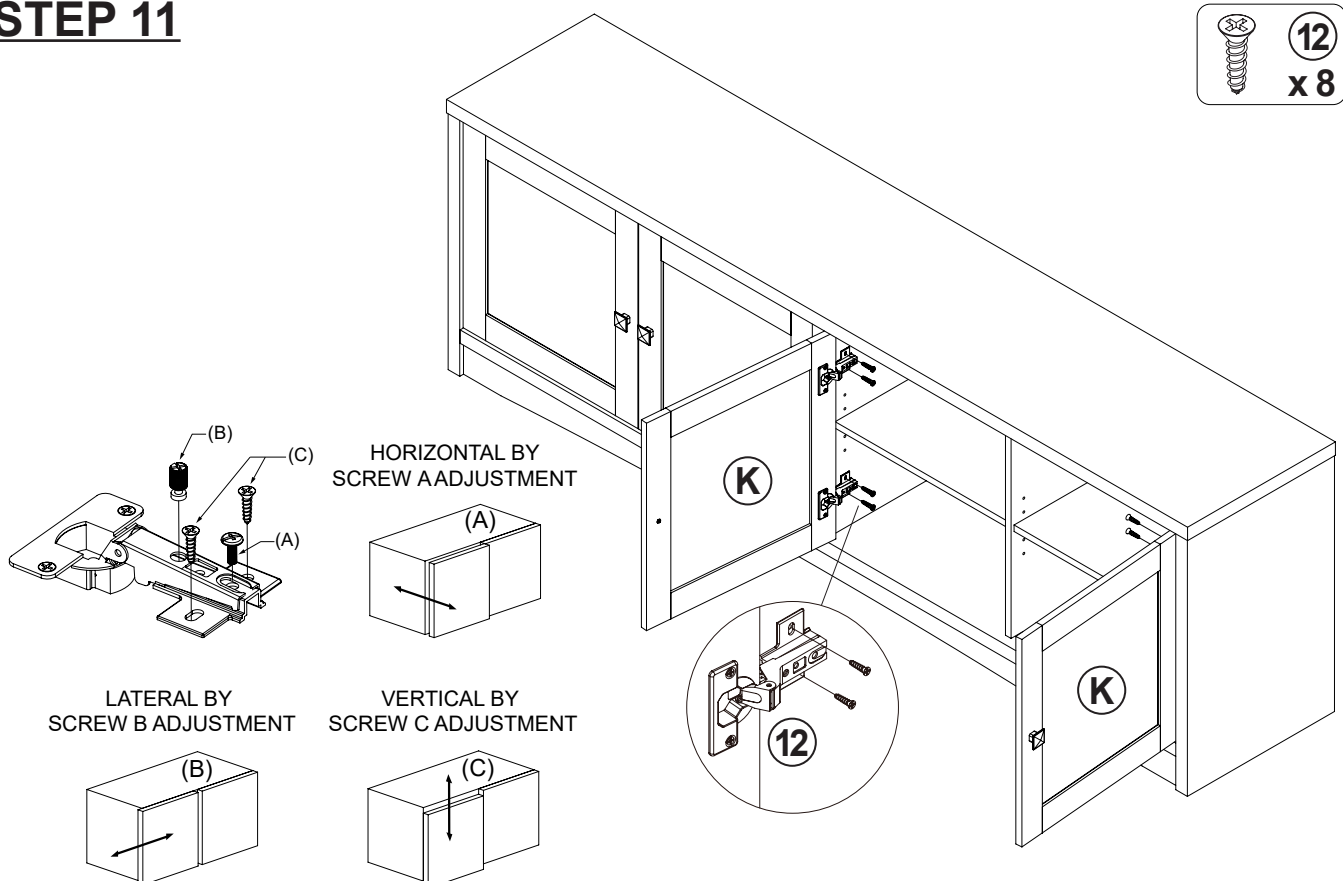
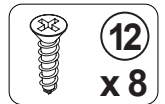

STEP 12

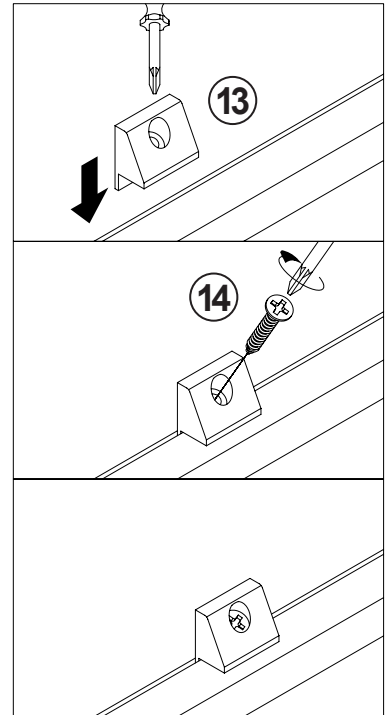
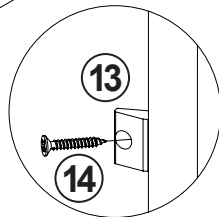
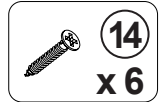
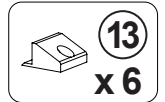
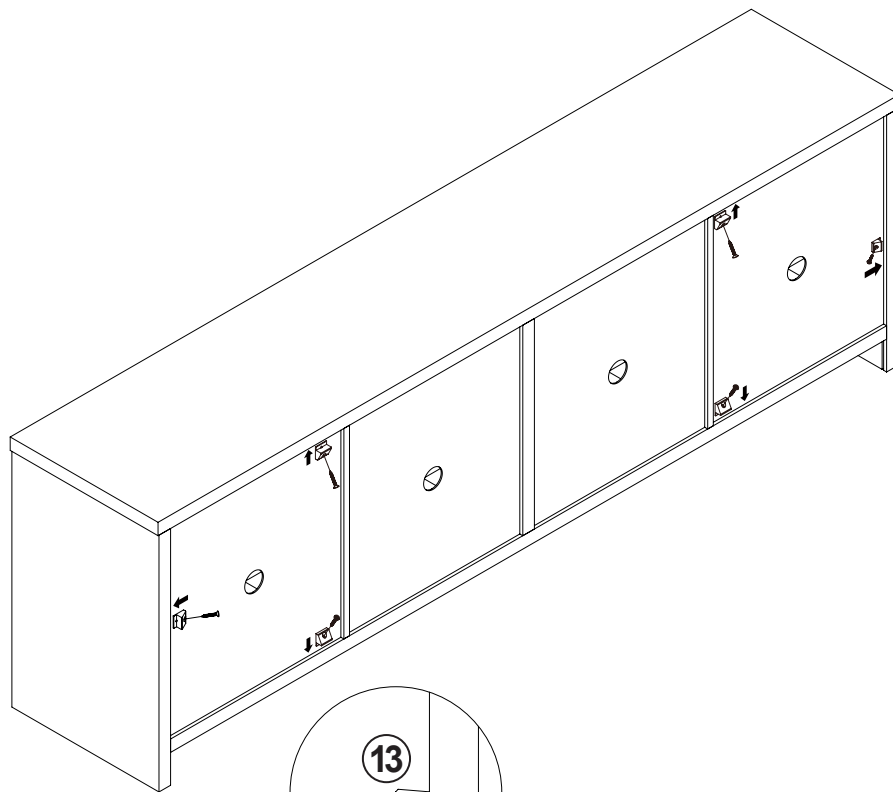

STEP 13

COMPLETE

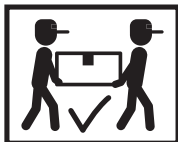
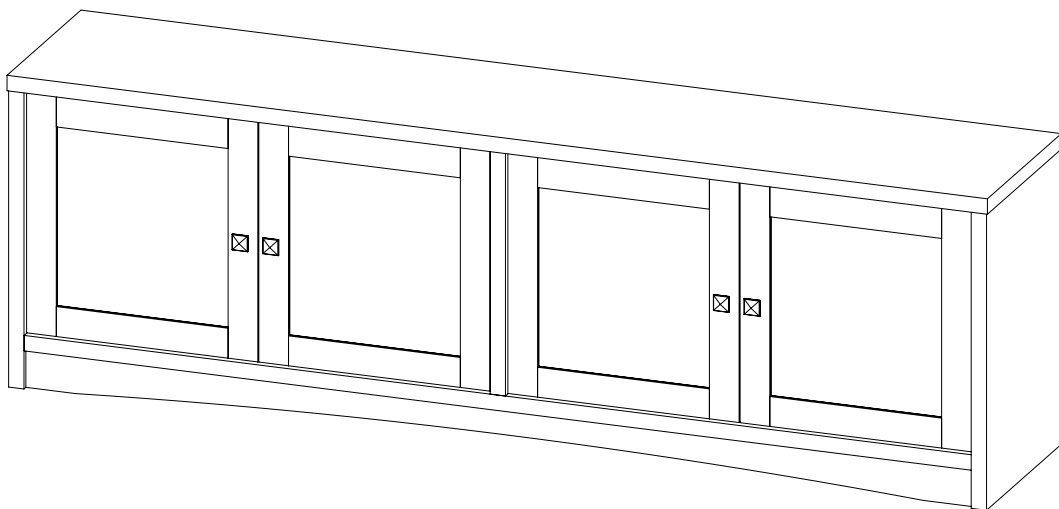

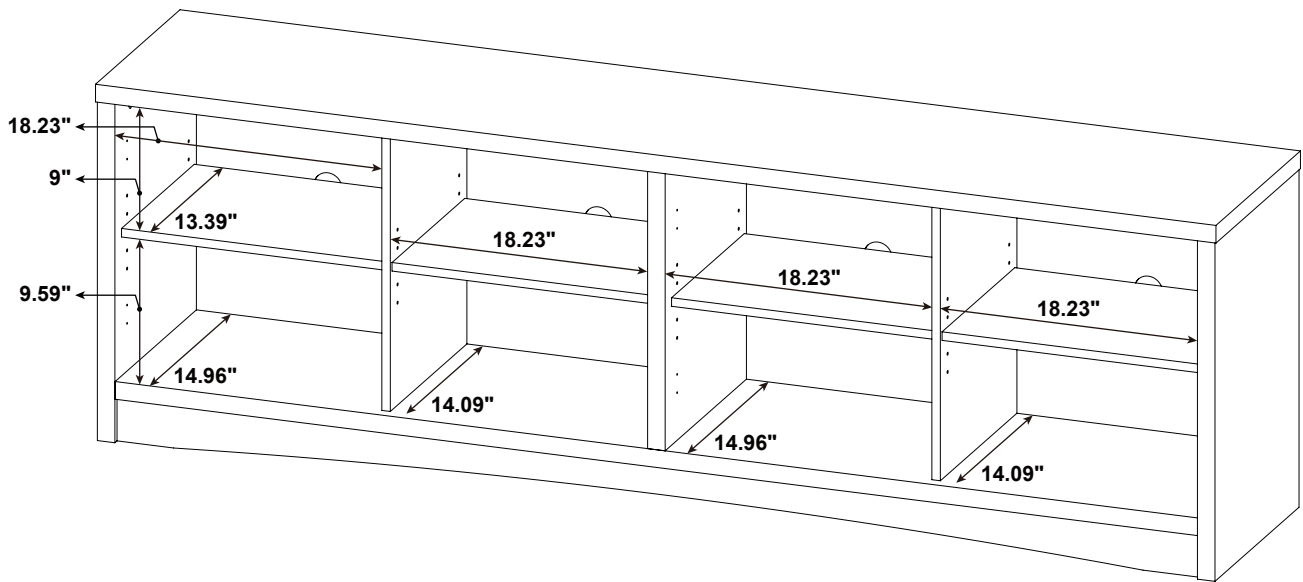
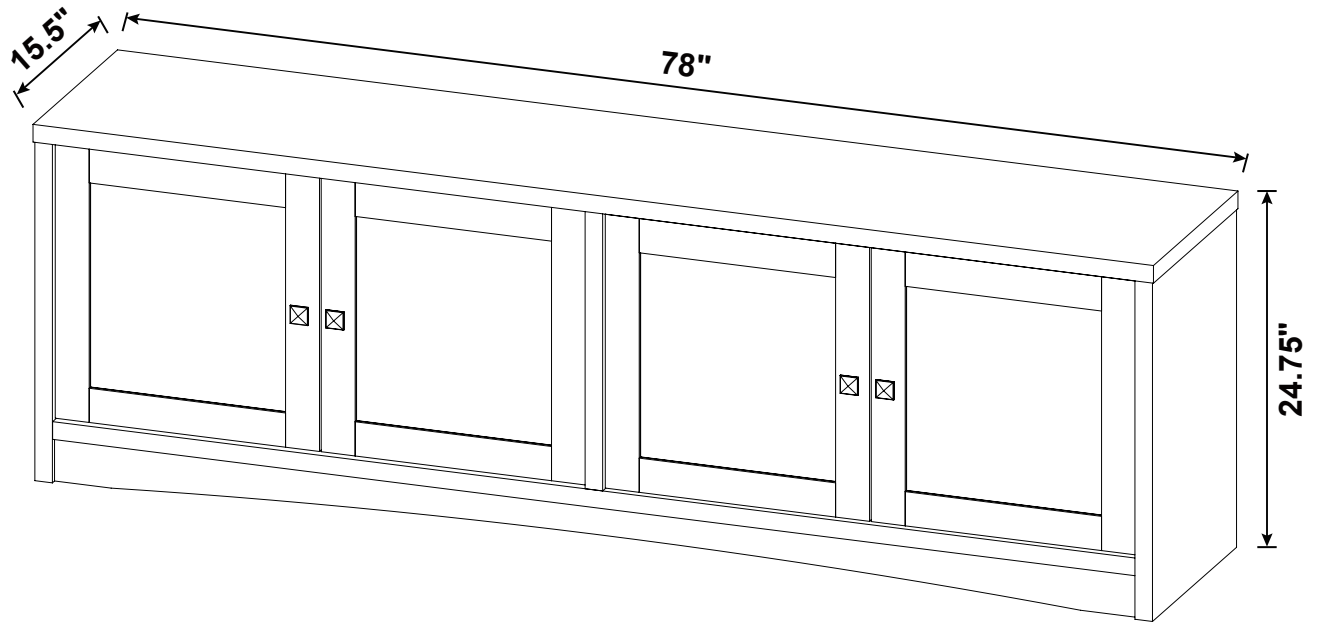

Note : Dimension tolerance $\pm 5\%$