

Recommended Maximum Weight

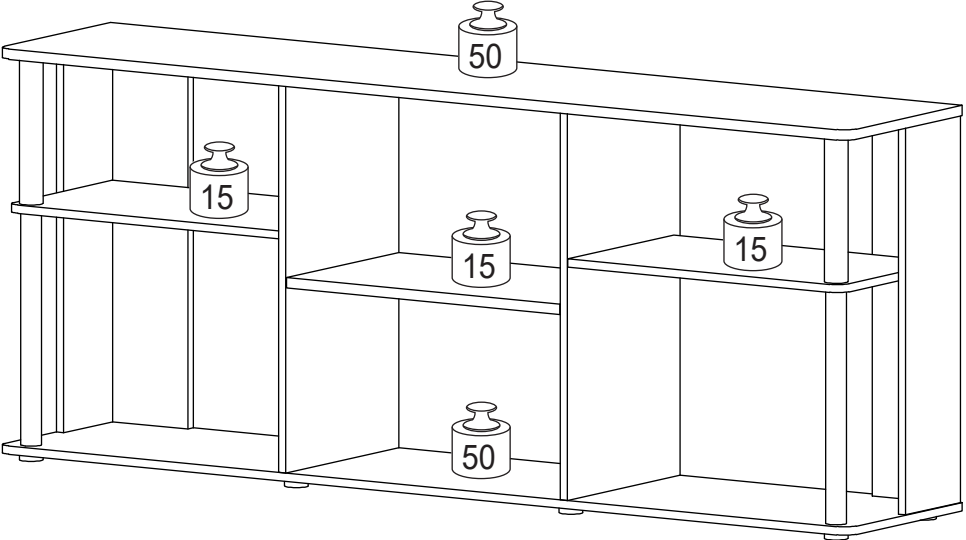

*Unit in Pound(lbs.)

WARNING:

- >This unit has been designed to support the maximum loads shown. Exceeding these load limits could cause sagging, instability, product collapse, and/or serious injury.
- >DO NOT allow children to climb on unit.
- > Put heavier items on lower shelves.

00:35
Approx. 35 minutes

Recomm. 2 Person





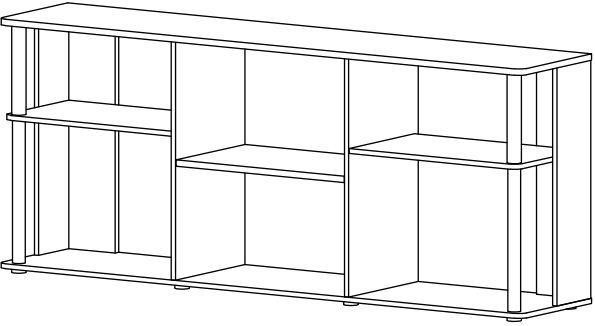

Tools Required

Assembly Instruction

TV Stand

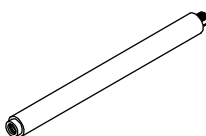
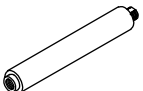

HARDWARE & PARTS LIST

NO	HARDWARE LIST	QTY
1	MINIFIX 1a  1b 	10sets
2	POZIHEAD SCREW 	20pcs
3	LONG POLE 	2pcs
4	MEDIUM POLE 	2pcs
5	MINI ROUND LEG 	8pcs
6	PVC ROUND RING 	4pcs
7	SHELF SUPPORT 	4pcs

NO	PARTS LIST	QTY
A	TOP PANEL	1pc
B	BOTTOM PANEL	1pc
C	LEFT SIDE PANEL	1pc
D	RIGHT SIDE PANEL	1pc
E	LEFT PARTITION PANEL	1pc
F	RIGHT PARTITION PANEL	1pc
G	SHELF PANEL	1pc
H	LEFT SHELF PANEL	1pc
I	RIGHT SHELF PANEL	1pc
J	LEFT BACK PANEL	1pc
K	RIGHT BACK PANEL	1pc

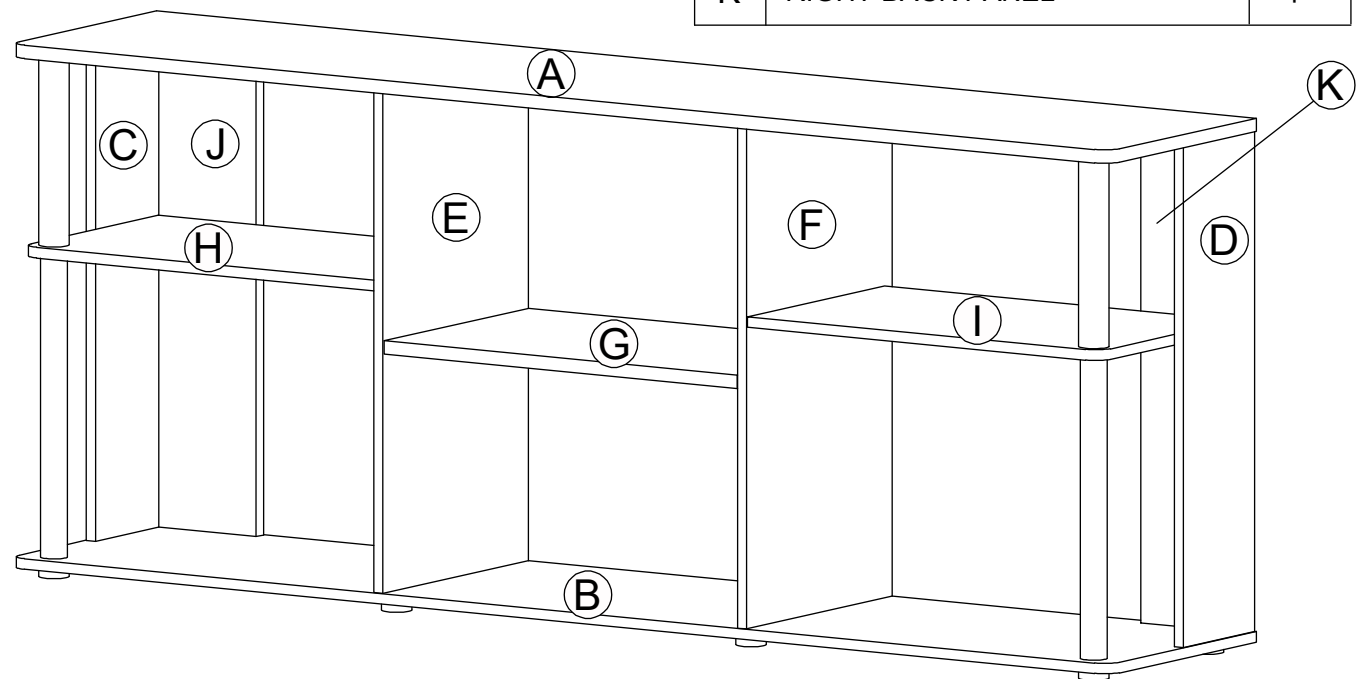

USEFUL HINTS BEFORE YOU START:

1. Read each step carefully before starting.
2. It is important that each step is performed in correct order to avoid difficulties.
3. Identify, sort and count the parts before assembly.
4. Assemble your furniture on packaging cardboard to prevent scratch or damage.
5. Clean the product with mild cleanser using soft dampened cloth. Do not use harsh or abrasive cleanser.
6. Using incompatible hardware might cause damage to product.

STEP 8

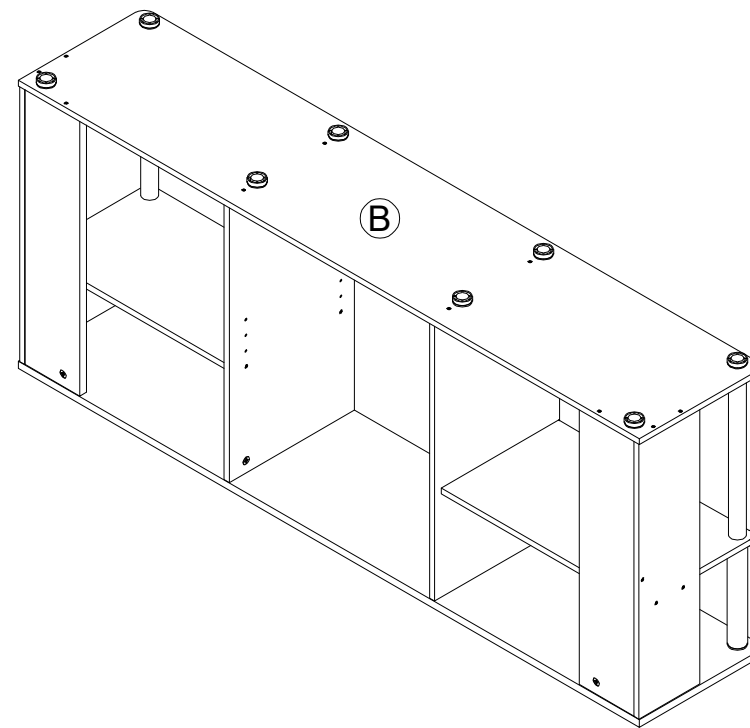

TURN 180°

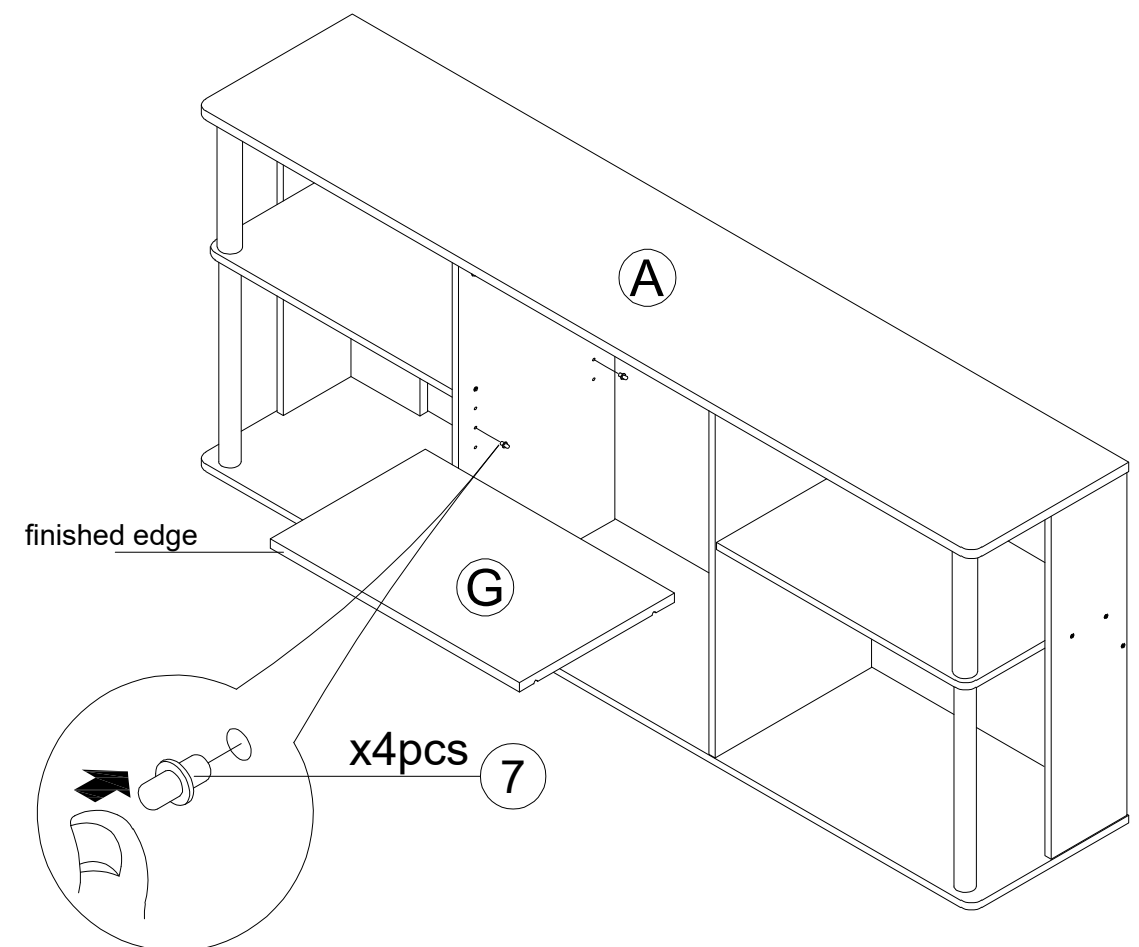

STEP 6

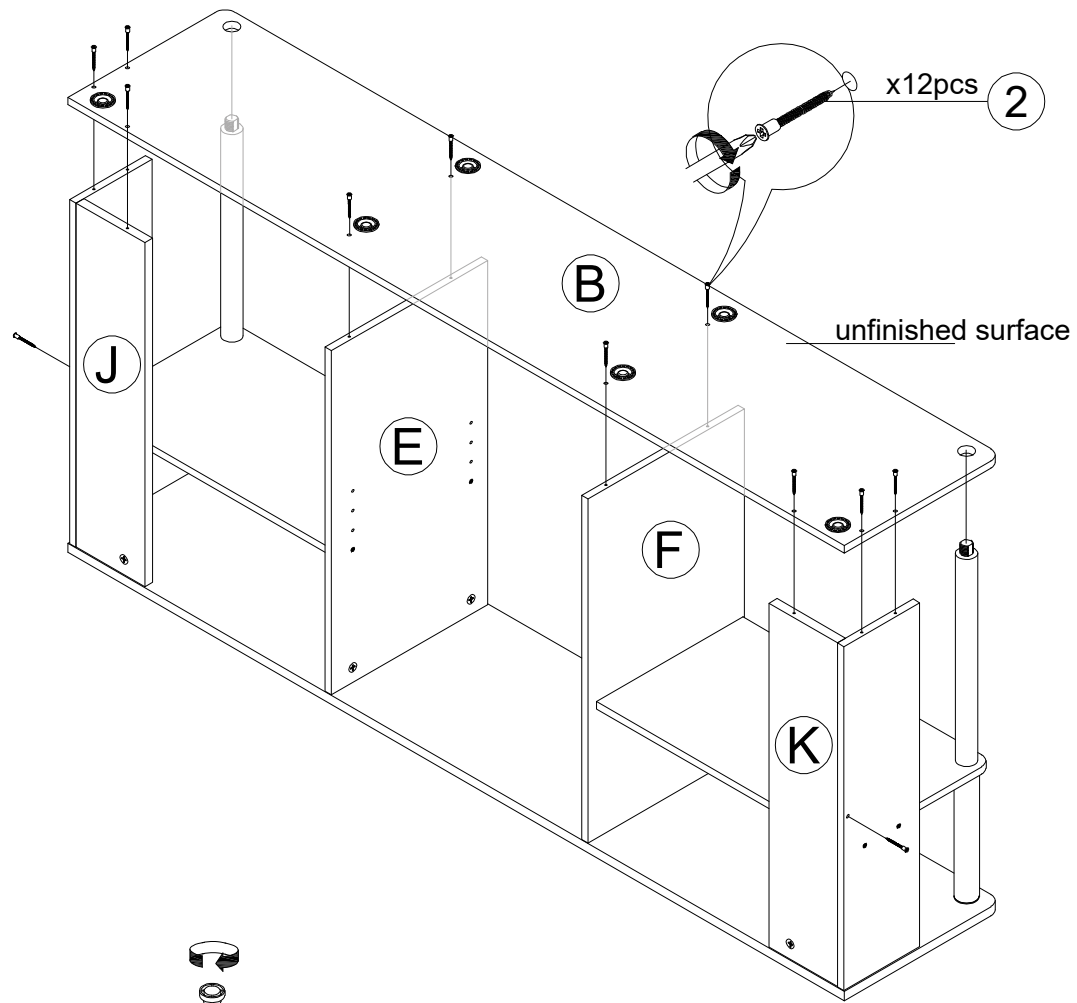

STEP 7

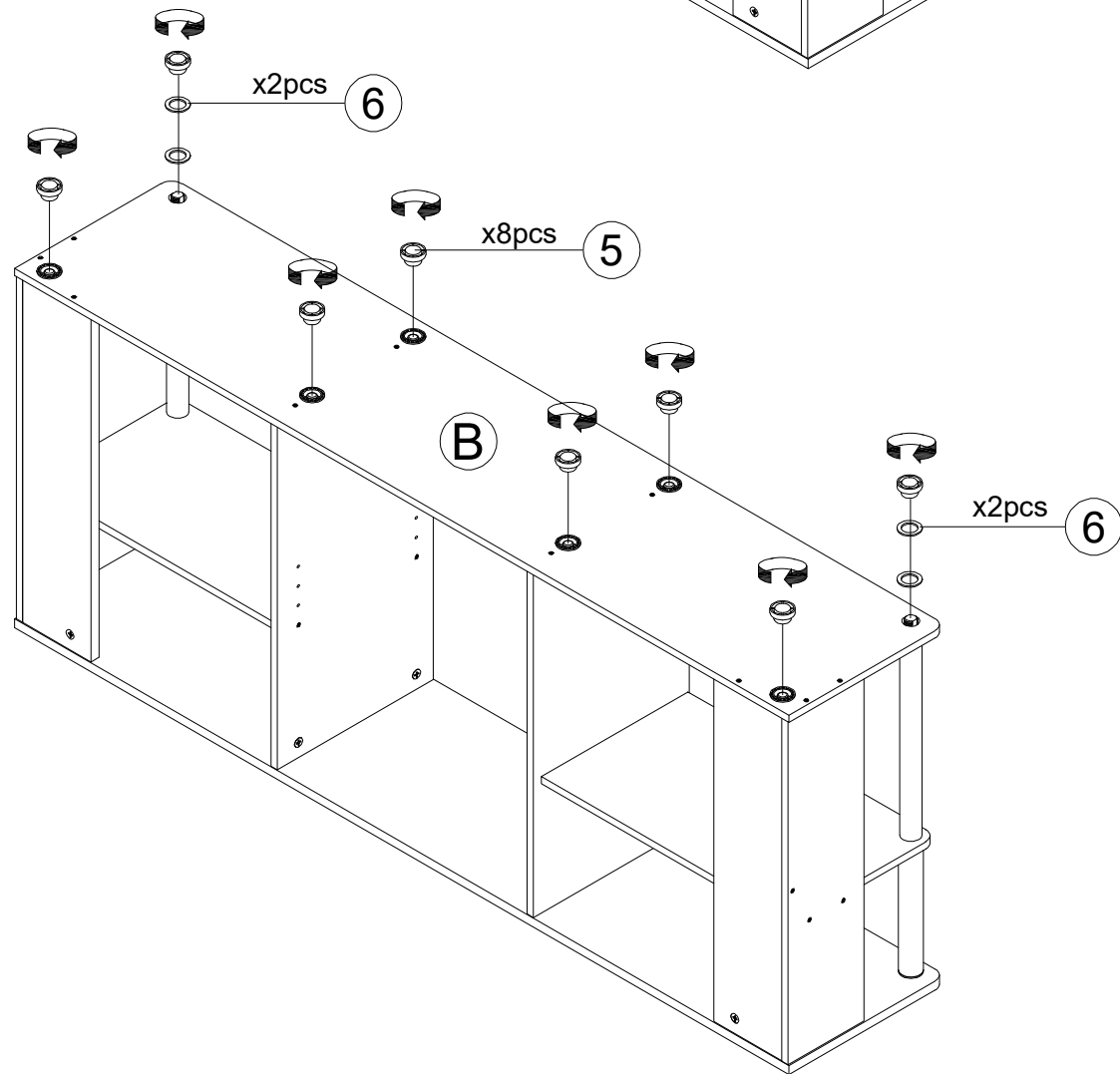

ASSEMBLY INSTRUCTIONS

BEFORE YOU BEGIN, PLEASE READ ASSEMBLY INSTRUCTIONS CAREFULLY,
FOLLOW THEM STEP BY STEP.

STEP 1

*keep for Step 3

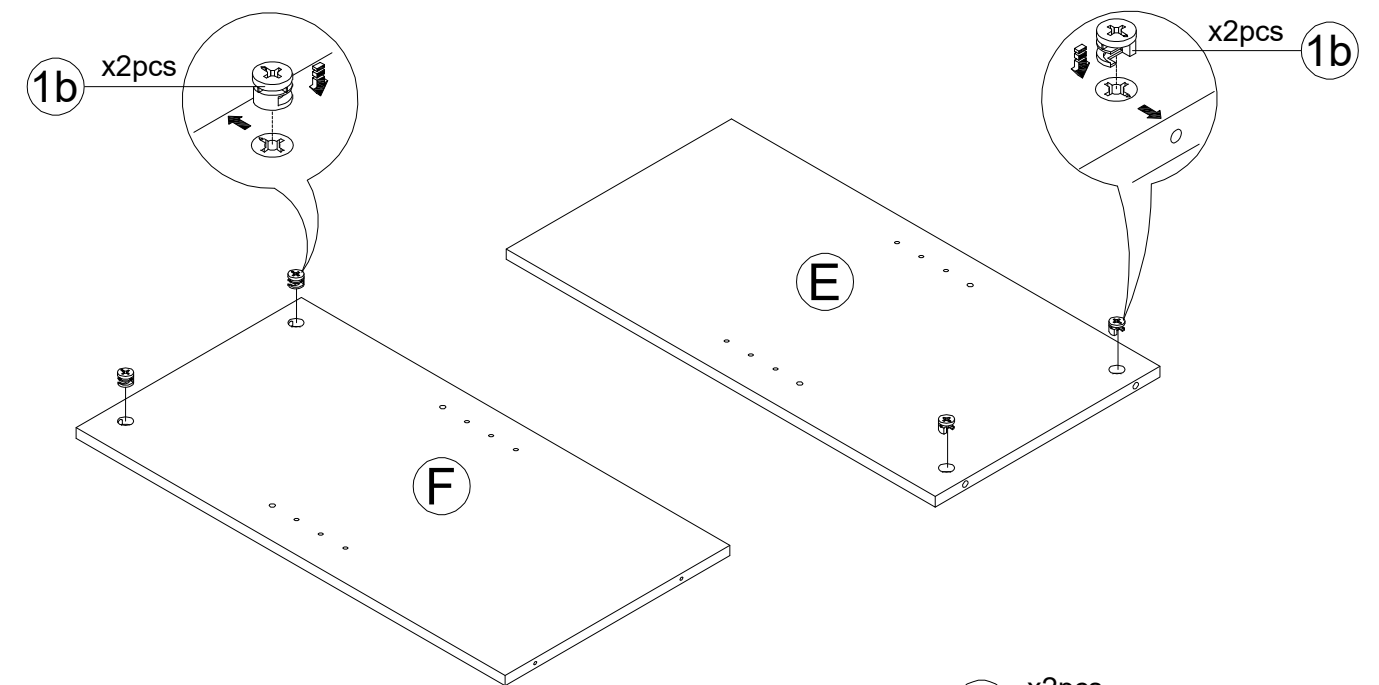

*keep for Step 3

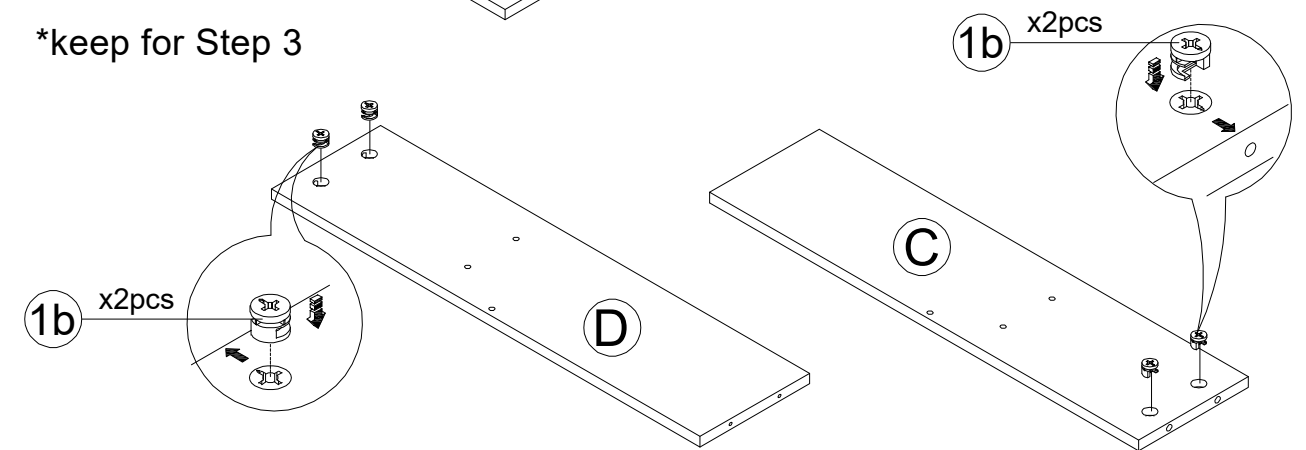

*keep for Step 5

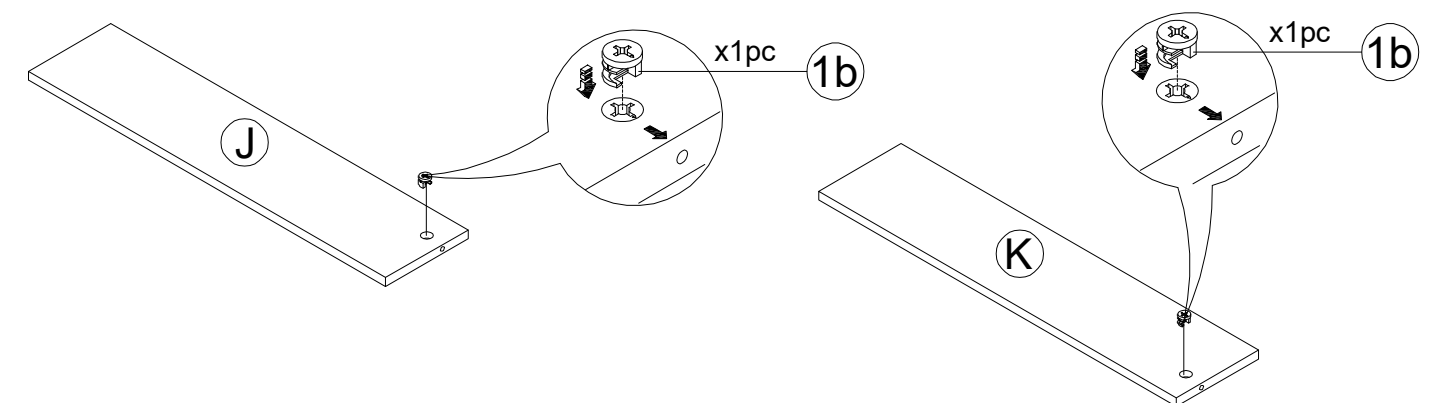

STEP 2

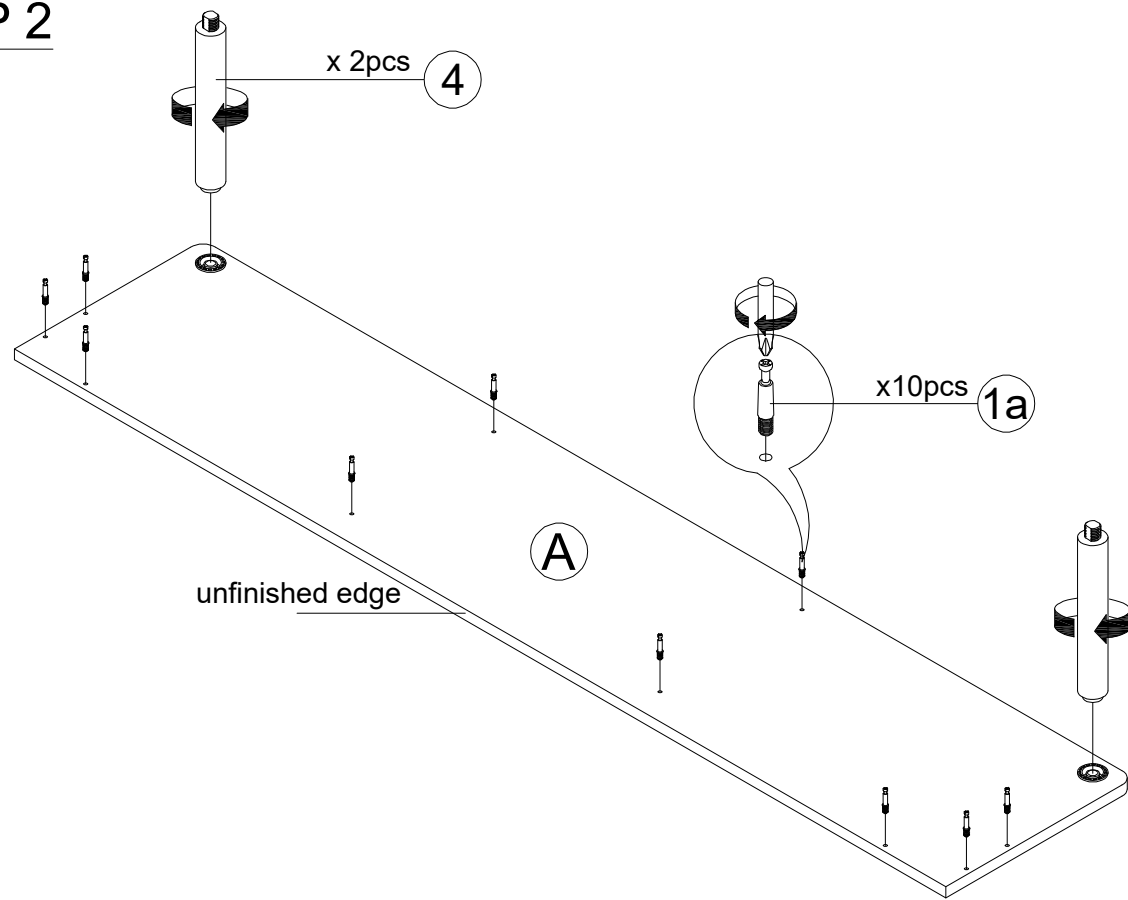

STEP 3

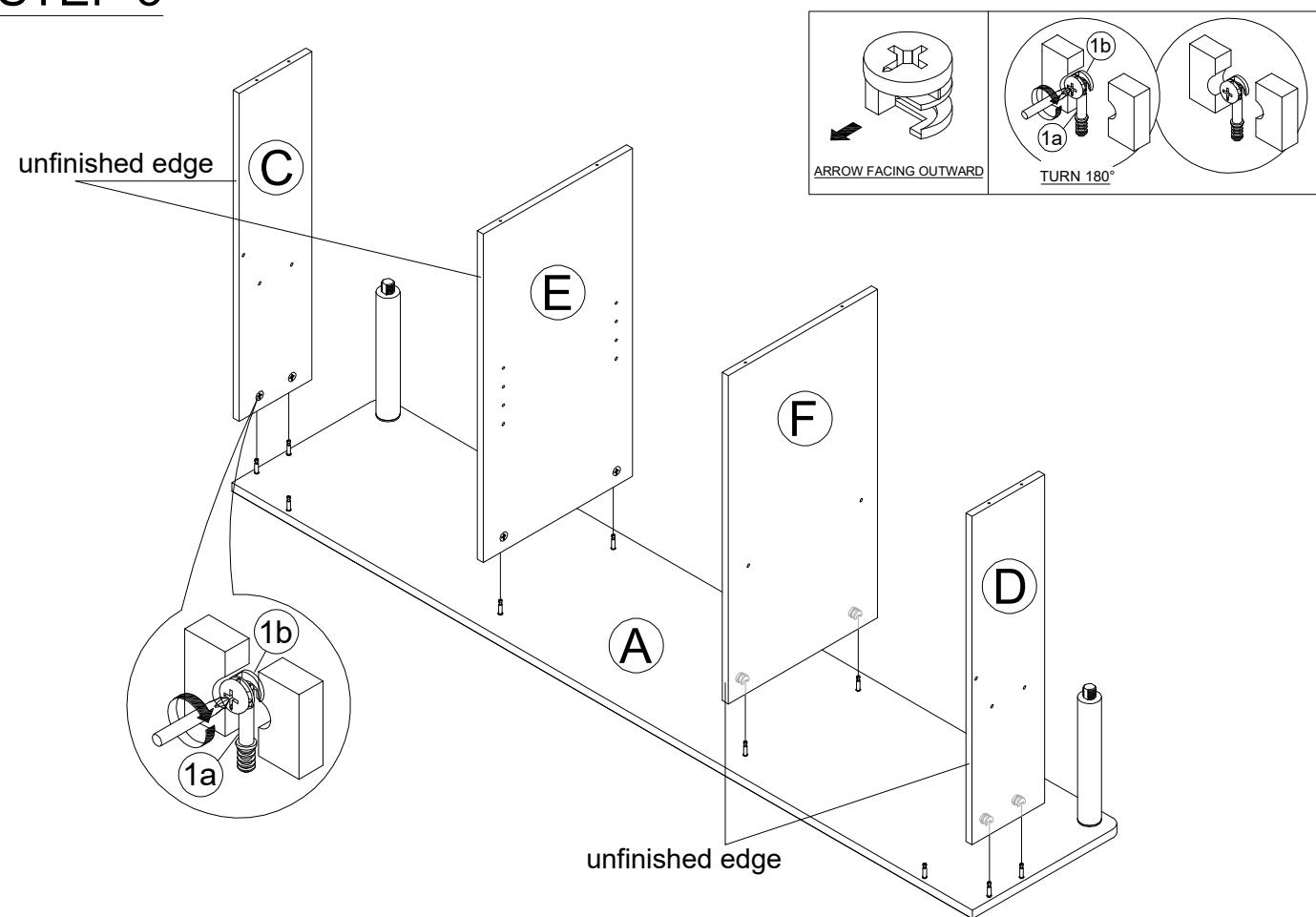

3

STEP 4

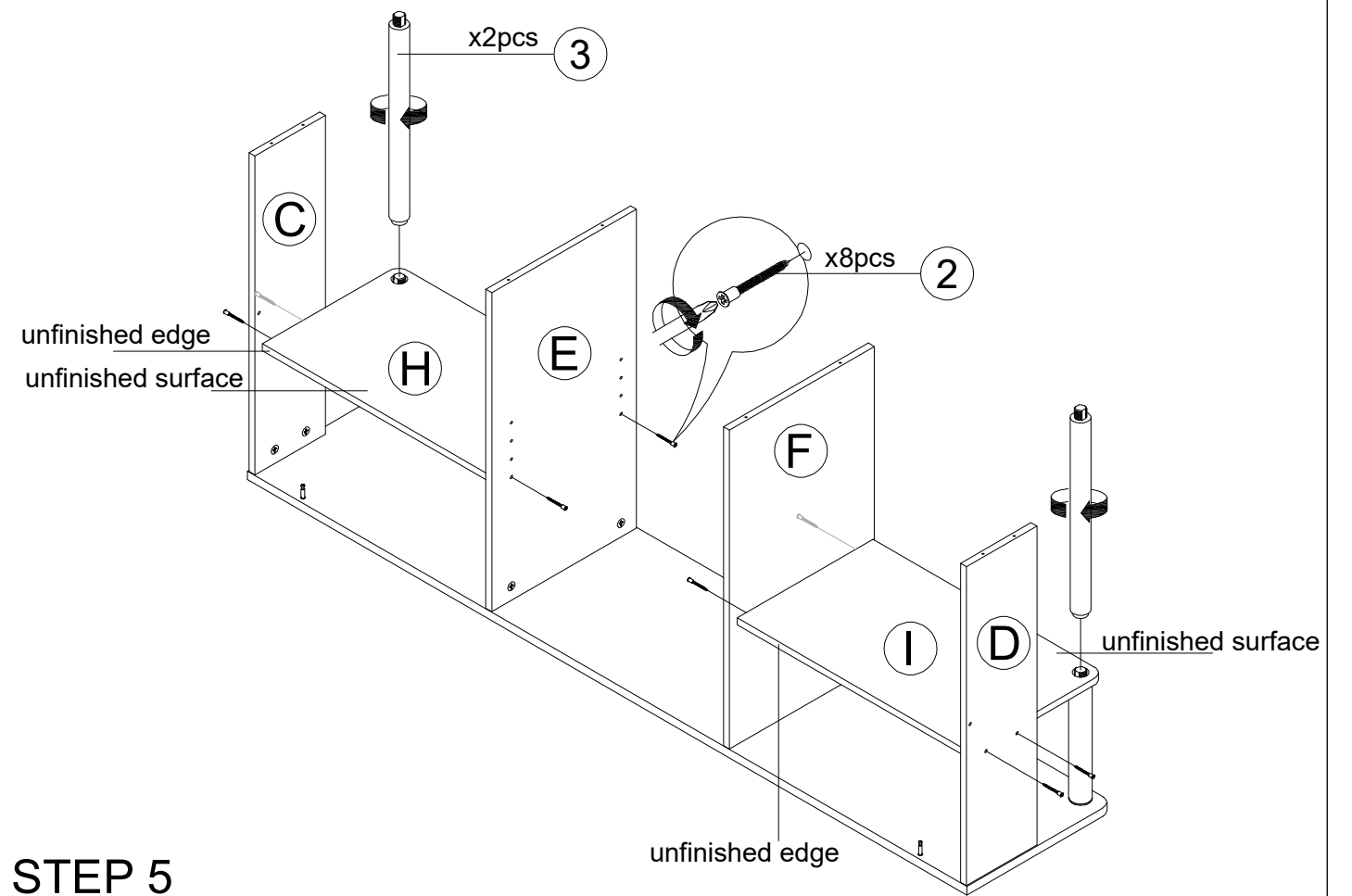

STEP 5

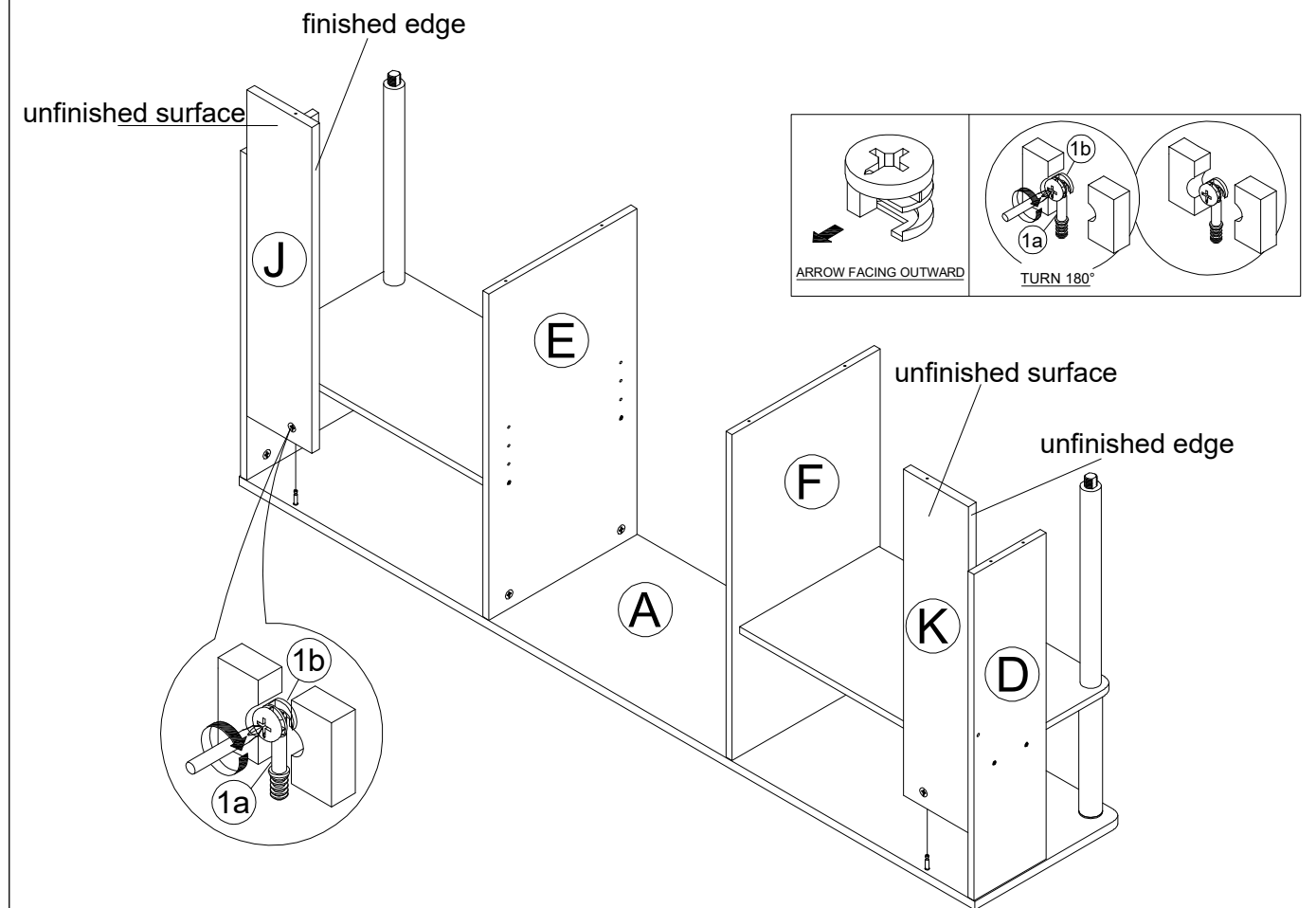

4