















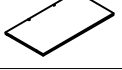

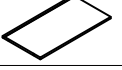





1



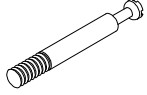

Parts List

NO.	Drawing	Dimension	QTY
1		800*400*15mm	1
2		800*400*15mm	1
3		342*380*15mm	1
4		580*380*18mm	1
5		580*380*18mm	1
6		342*380*15mm	1
7		427*380*15mm	1
8		714*380*15mm	1
9		427*380*15mm	1
10		714*380*15mm	1
11		434*409*15mm	1

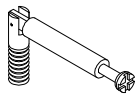
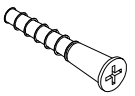
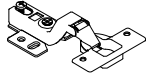
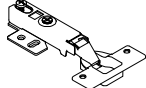
NO.	Drawing	Dimension	QTY
12		434*409*15mm	1
13		434*60*15mm	1
14		434*60*15mm	1
15		457*422*15mm	1
16		457*422*15mm	1
17		310*356*15mm	1
18		310*356*15mm	1
19		714*120*15mm	1
20		724*280*4mm	1
21		714*160*15mm	1
22		714*50*15mm	1

Hardware Fitting

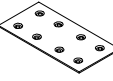
NO.	Drawing	QTY
A		50
B		58
C		8
D	 7*38mm	8
E		4
F		4

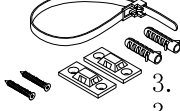
NO.	Drawing	QTY
G	 3.5*14mm	52
H		8
I	 3.0*14mm	8
J	 90*45mm	2
K		1
L	 3.5*35mm 3.5*14mm	2

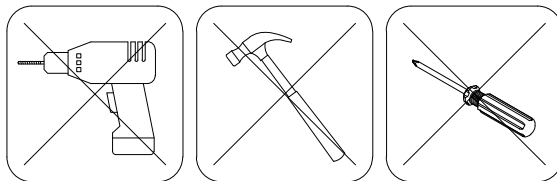

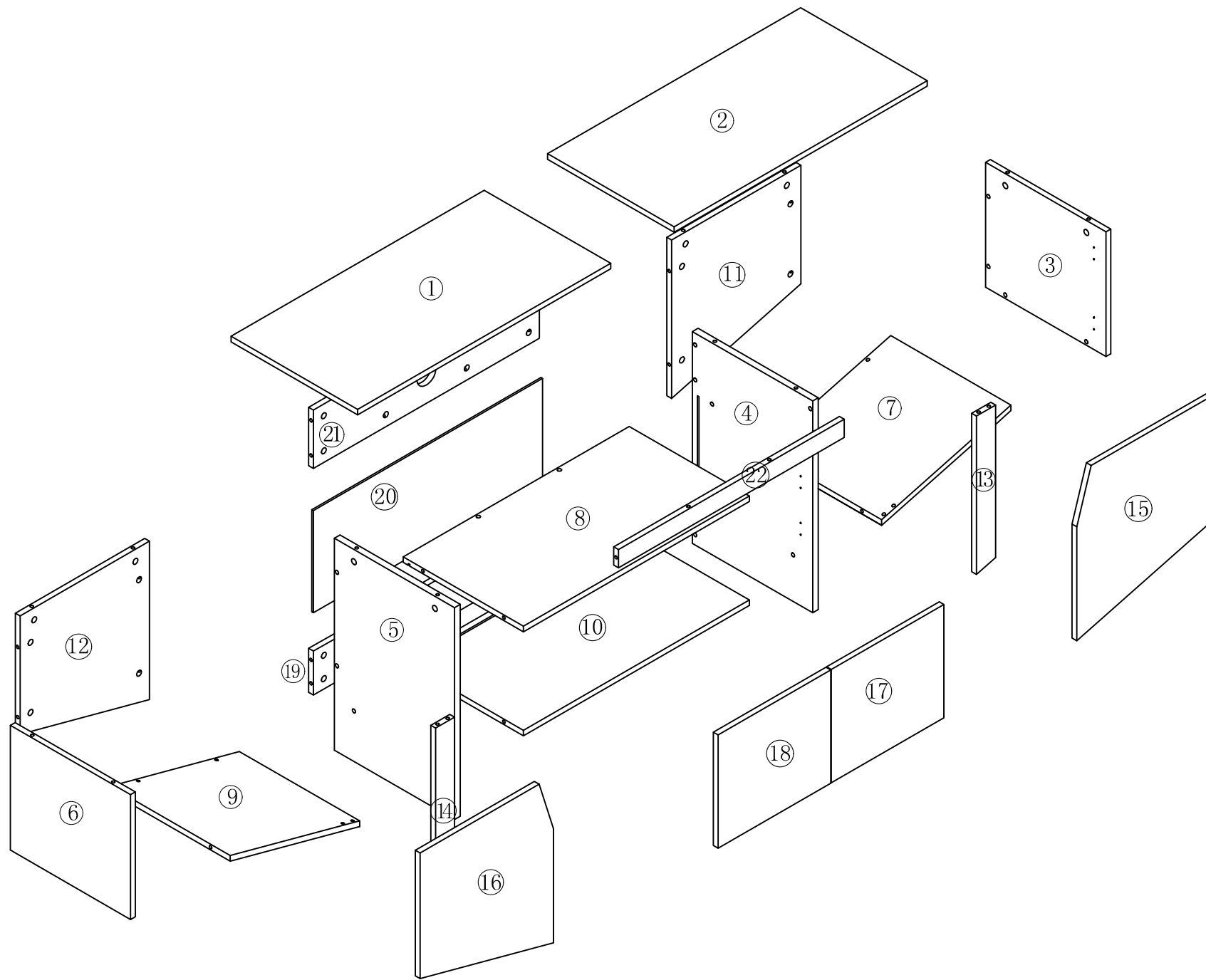

Cam Coupling Using Methods

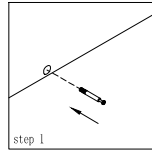

Step1.

Connect the cam coupling A as directed in the assembly instructions using hand.

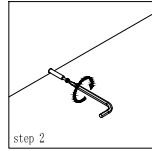

Step2.

Screw the cam coupling A as directed in the assembly instructions.

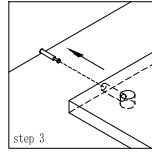

Step3.

Push the cam coupling A into the entry hole.

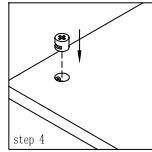

Step4.

Insert the cam coupling B as shown in the instructions.

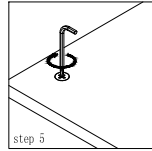

Step5.

Turn the cam coupling B clockwise with a screwdriver

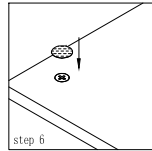

Step6.

Put on Beautycam.

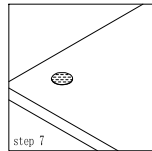



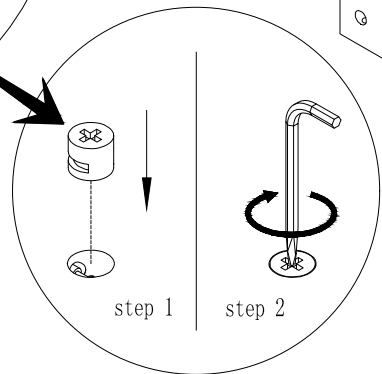
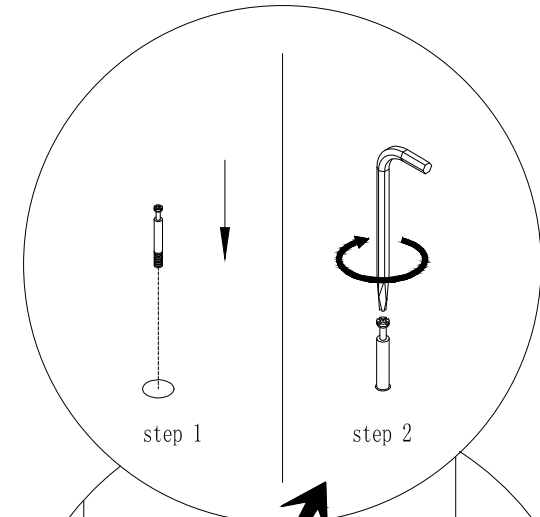
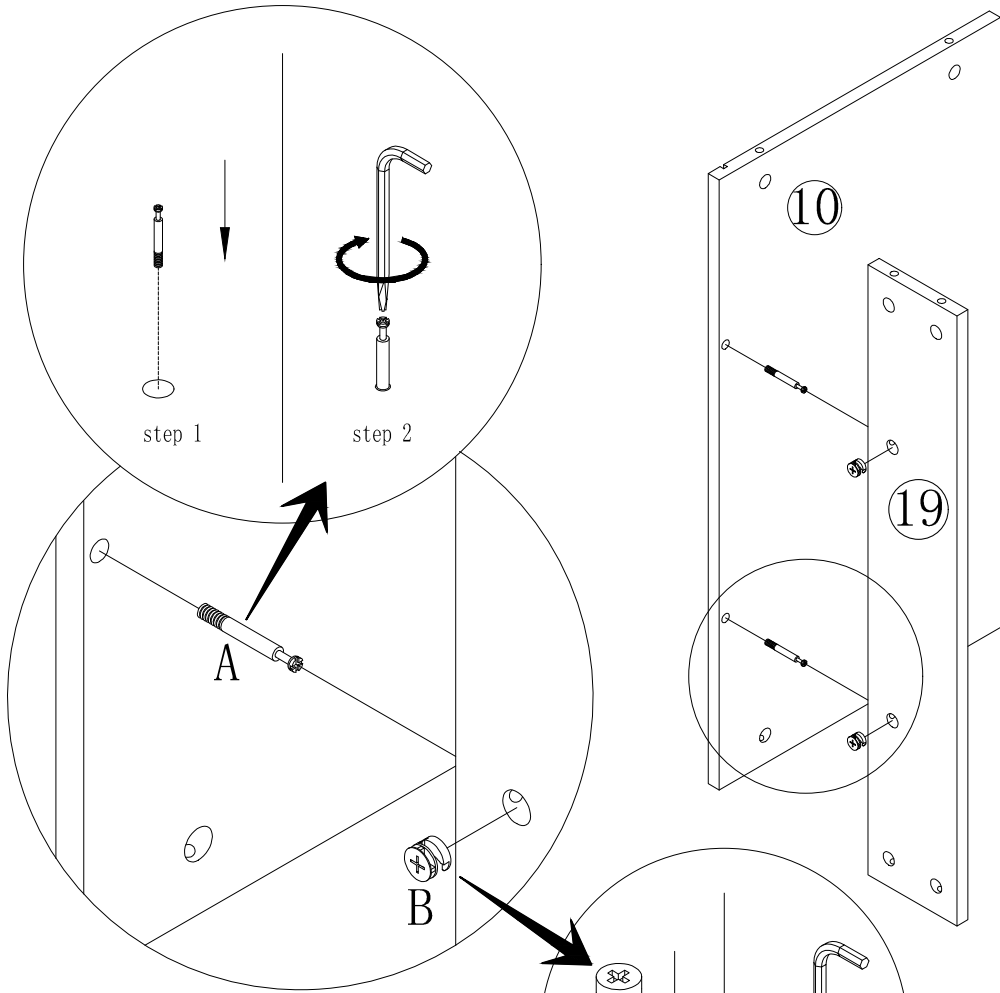

Step7.

Finished.

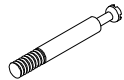
You should feel a click when the camlock is locked in place.
The joint is now secure.



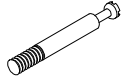

A		2
B		2

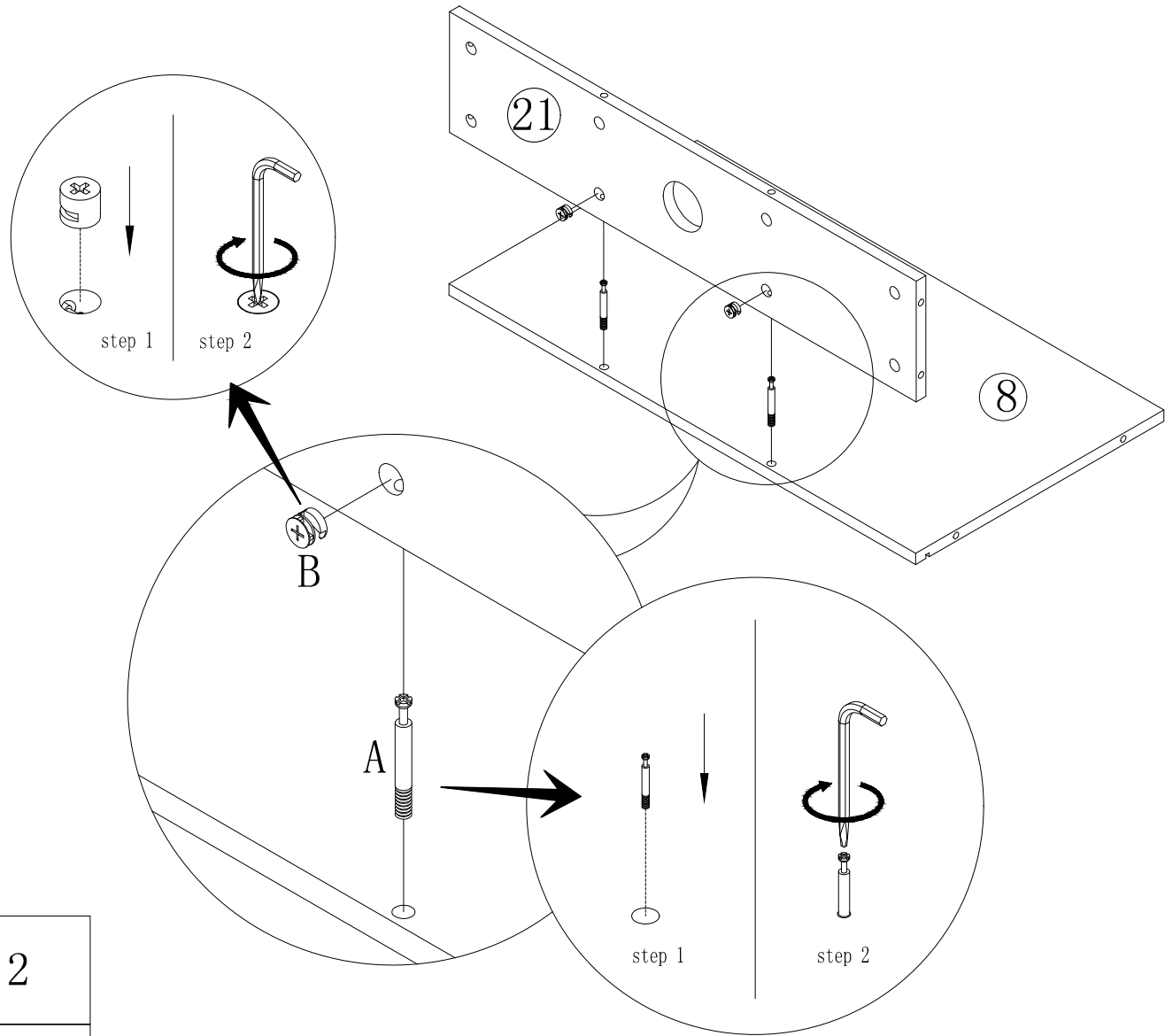
A		2
B		2

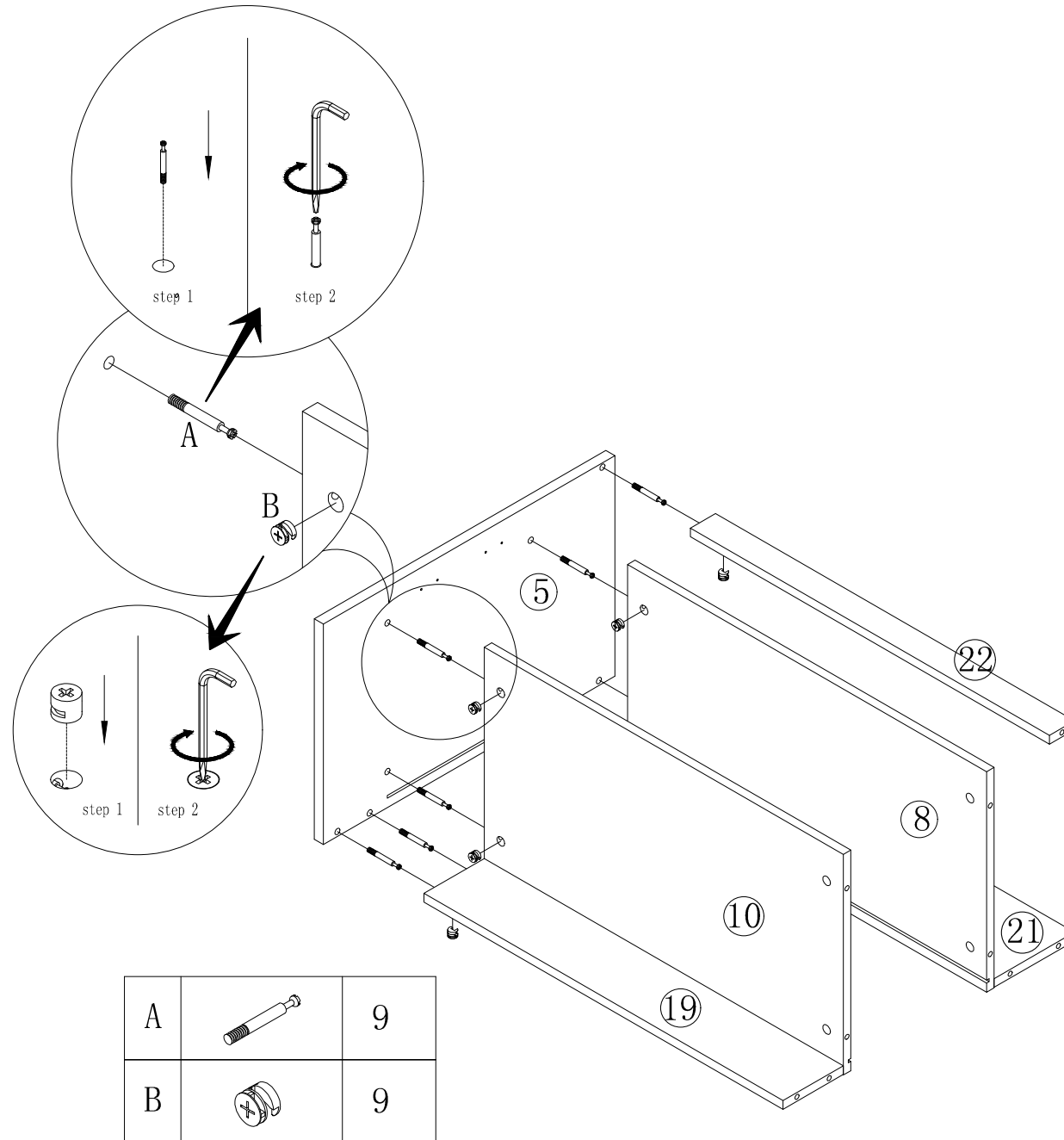



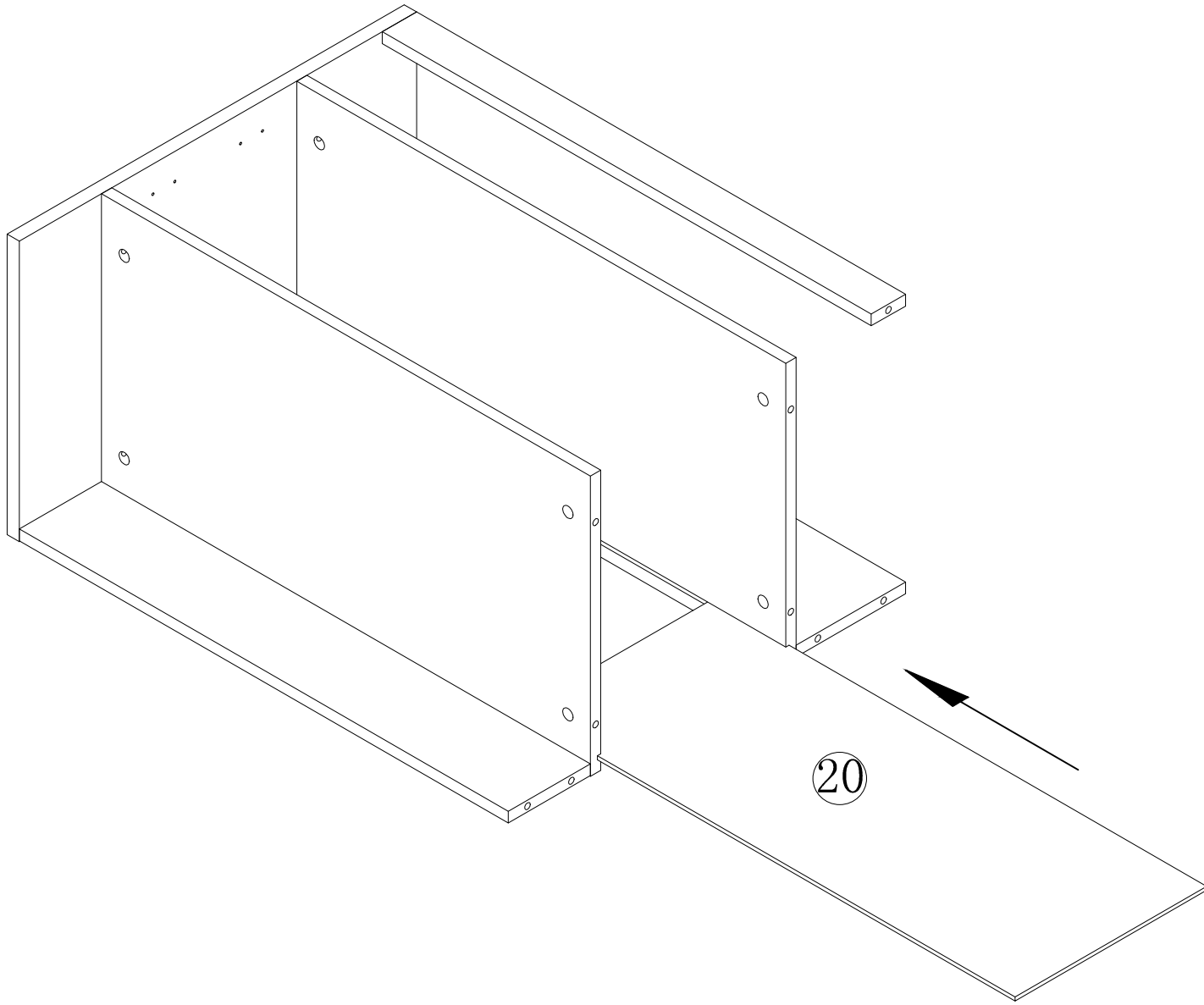

A		9
B		9

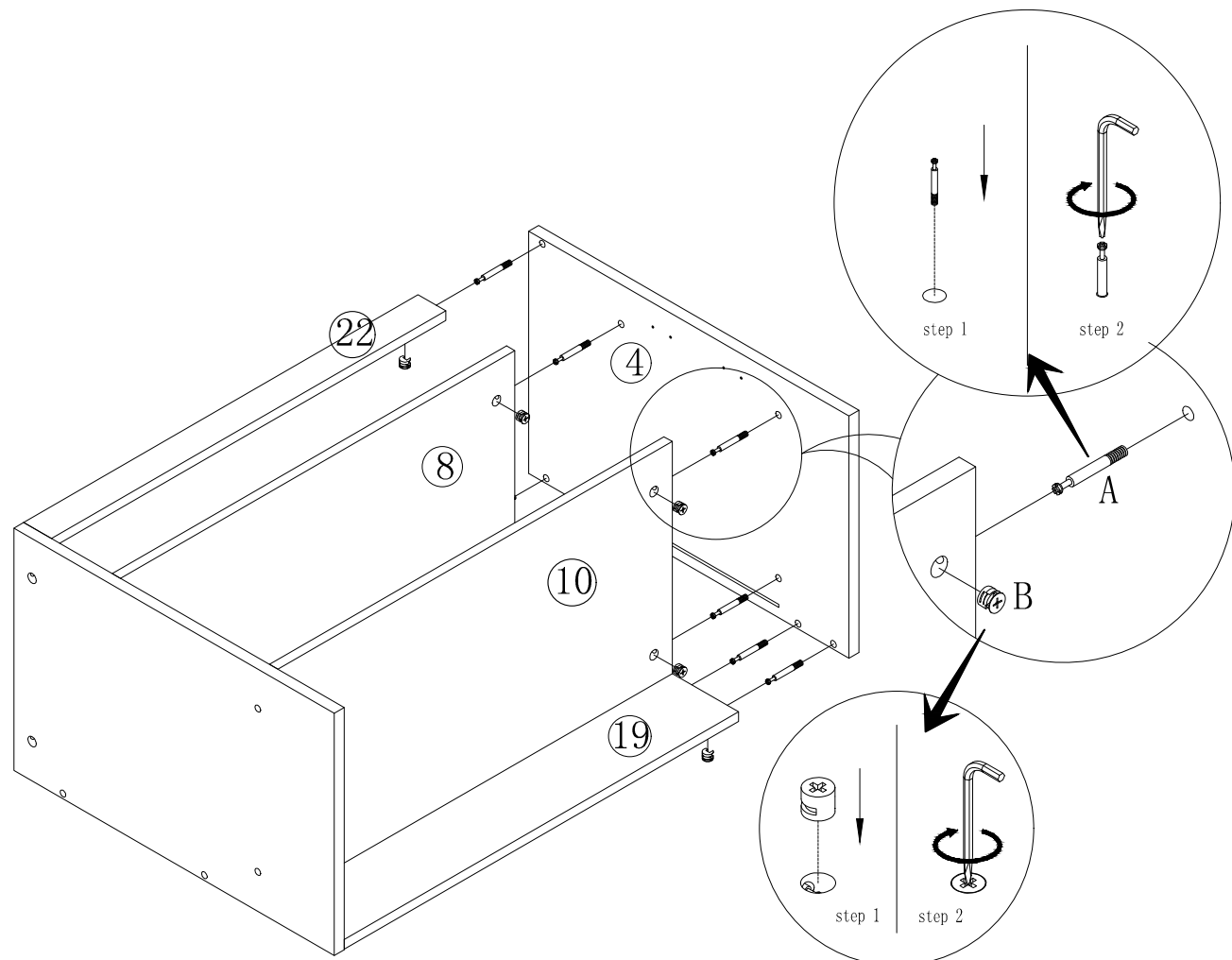





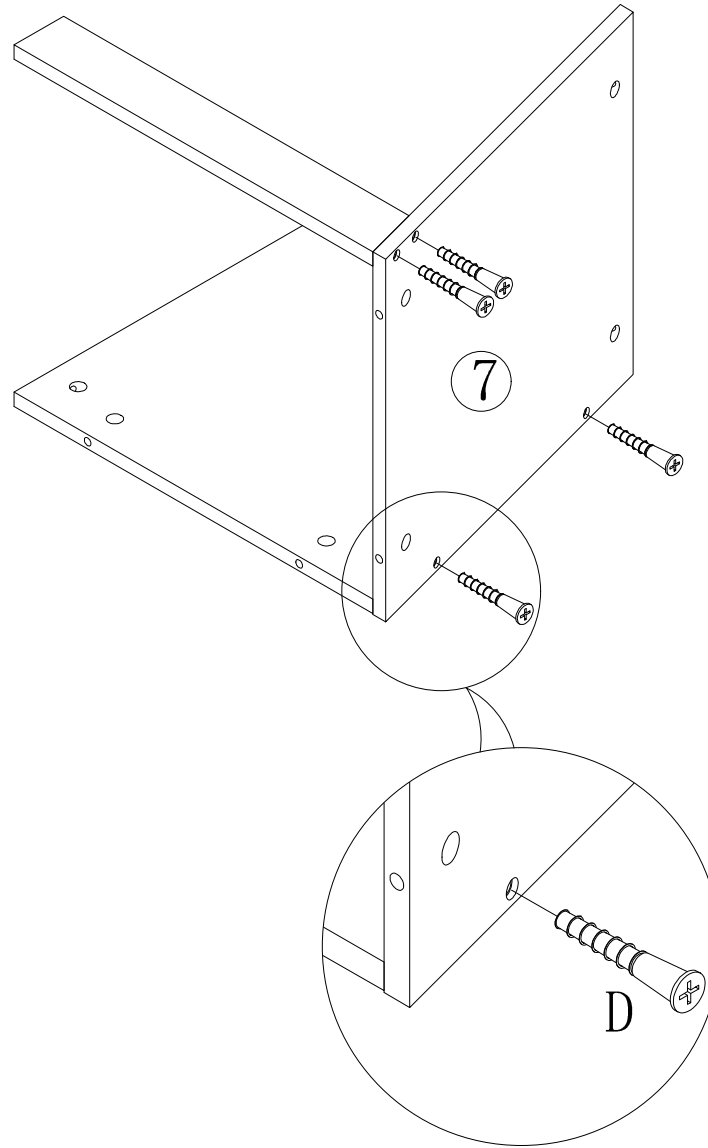
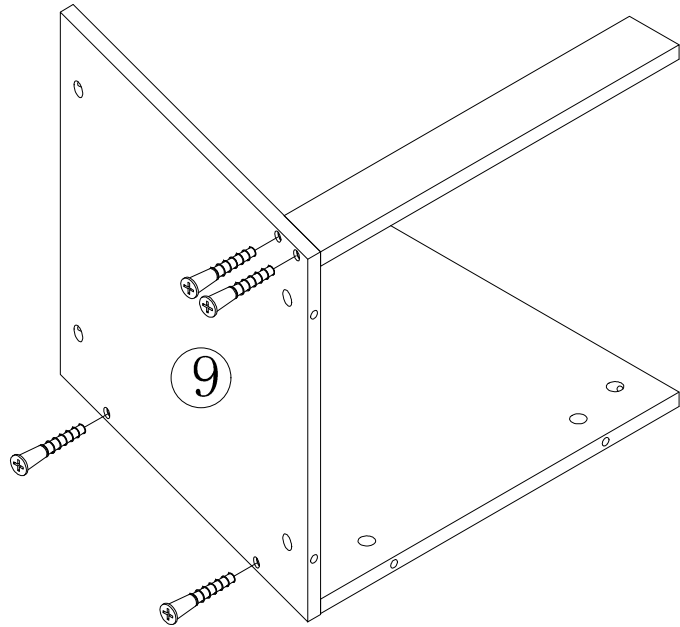

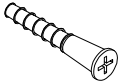
A		9
B		9

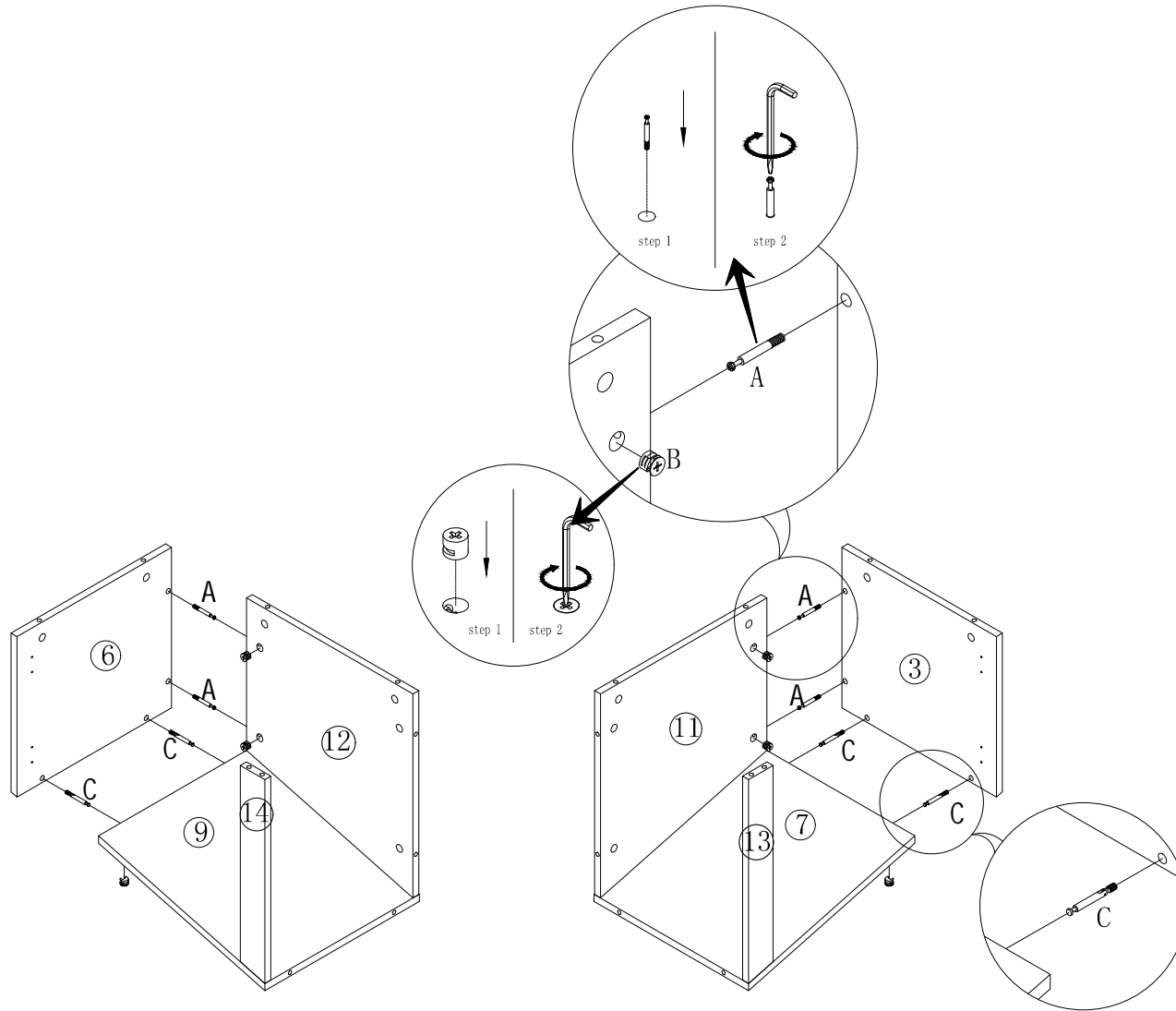

D		8
---	---	---



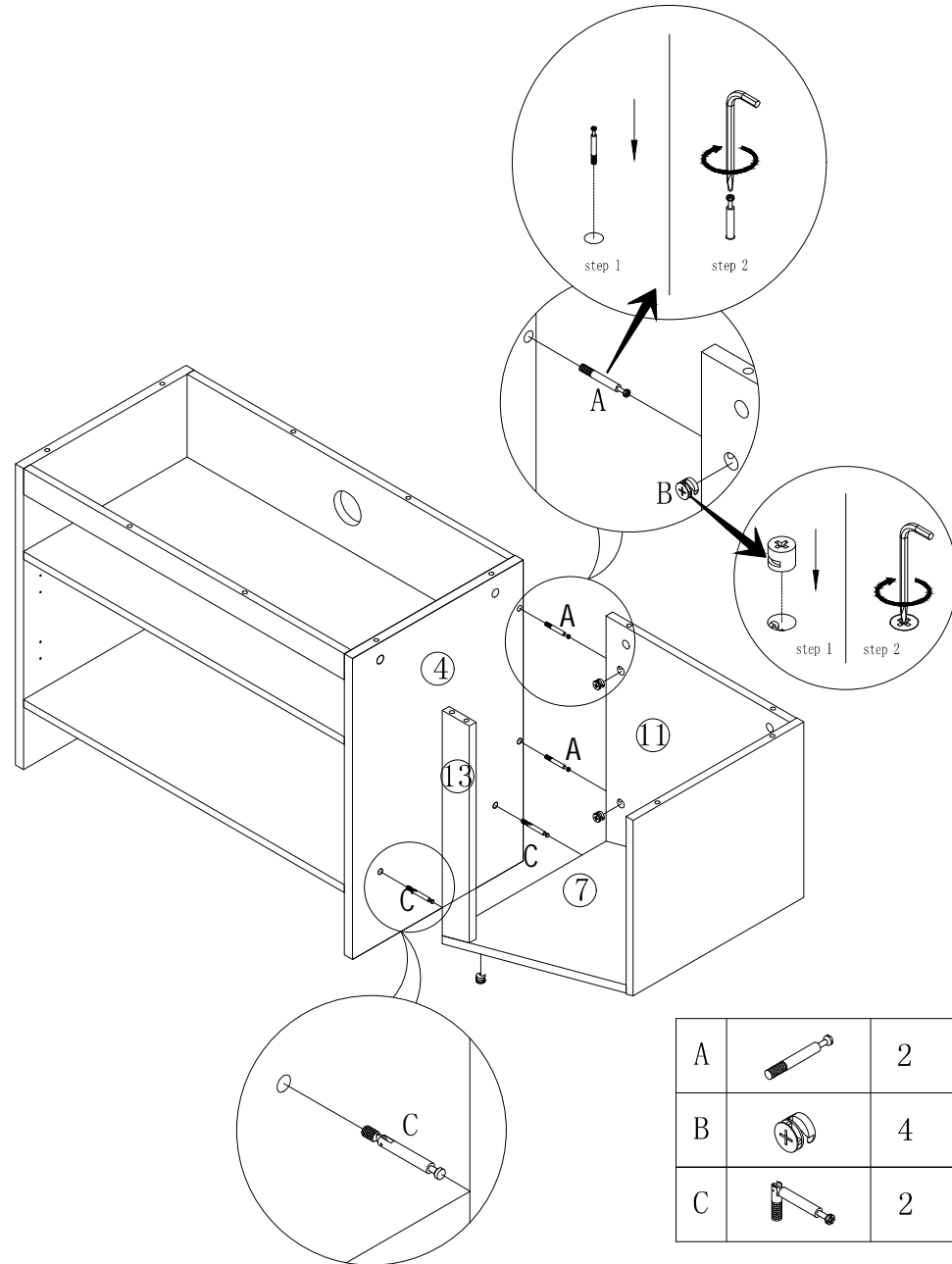

A		4
B		8
C		4

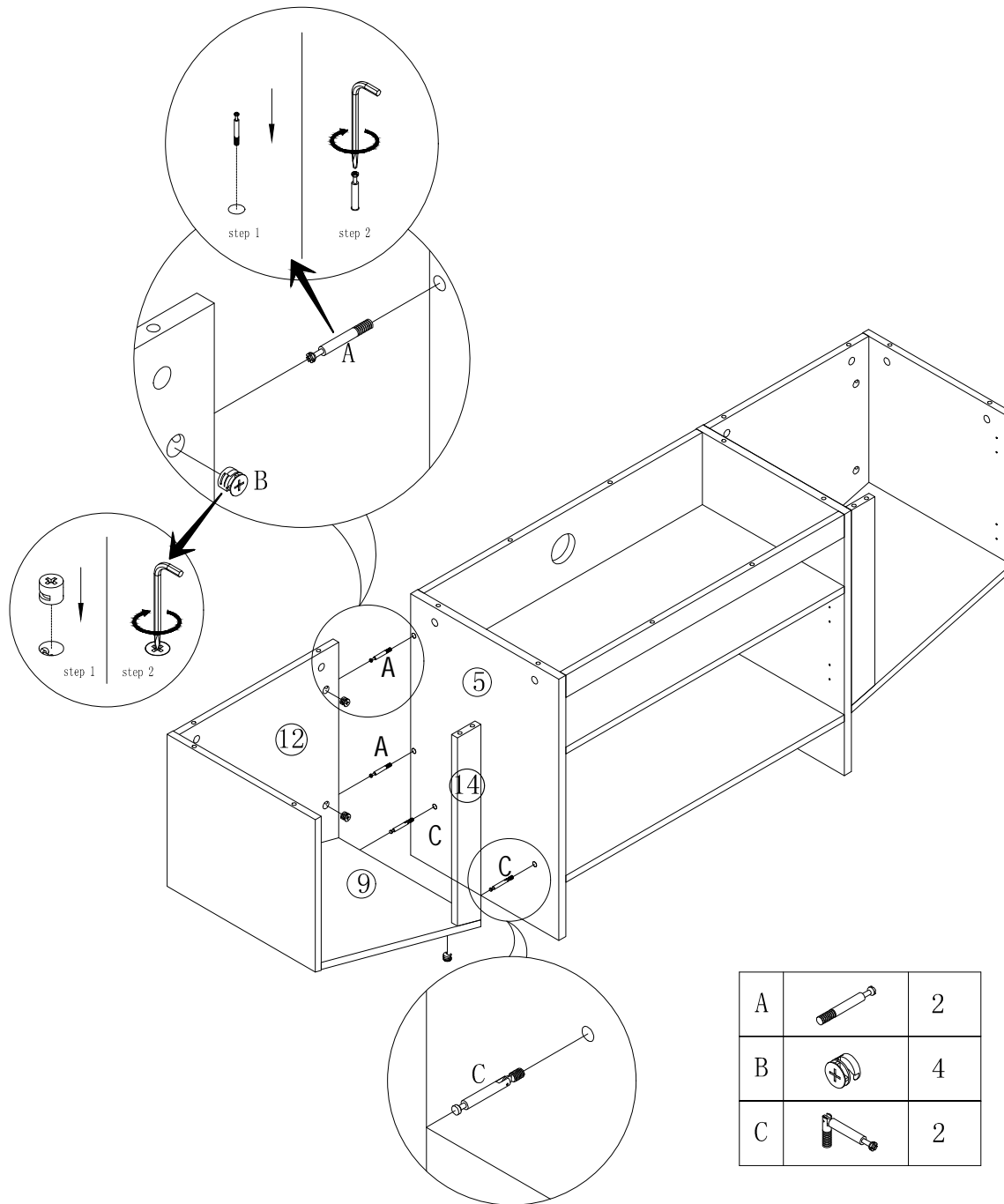

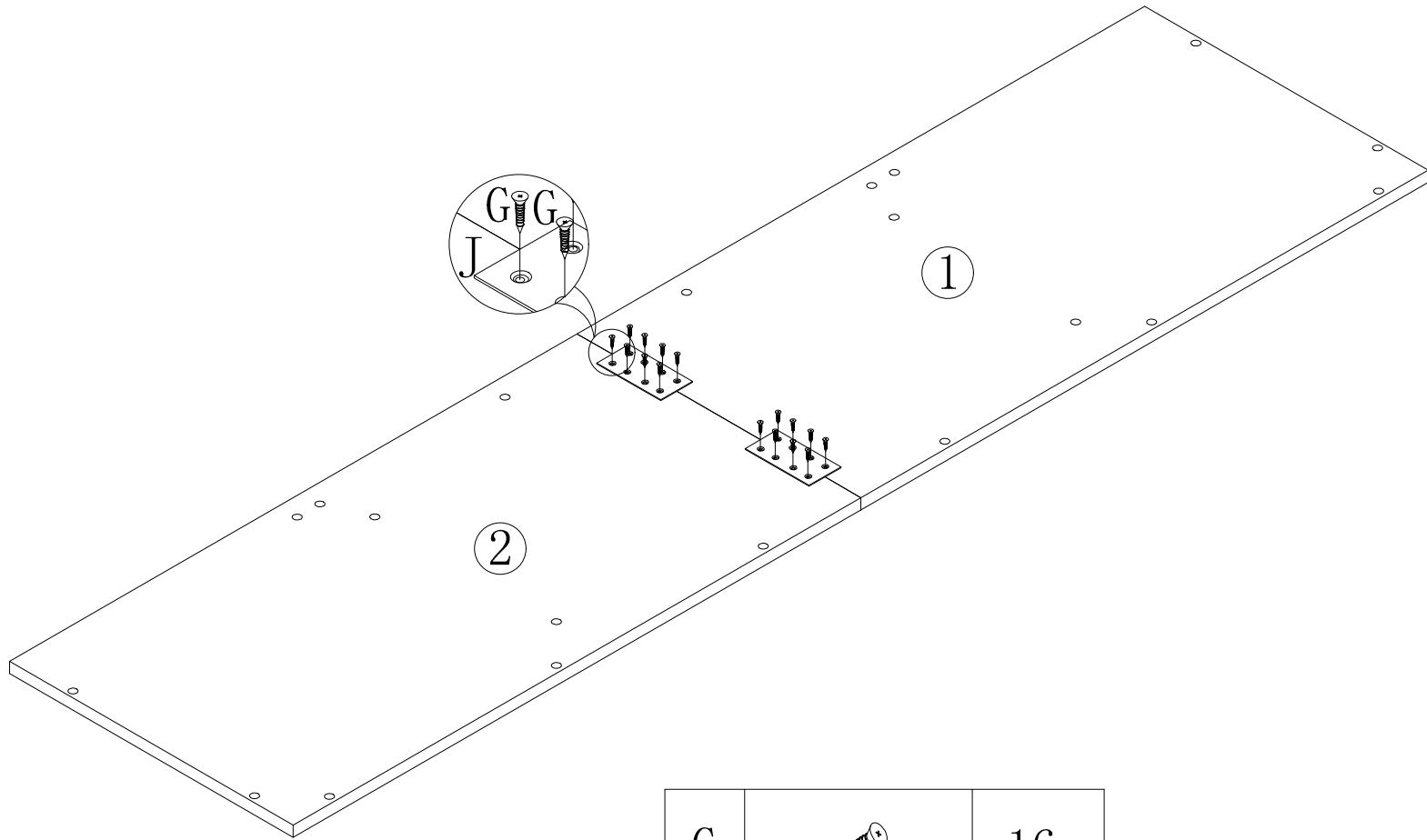





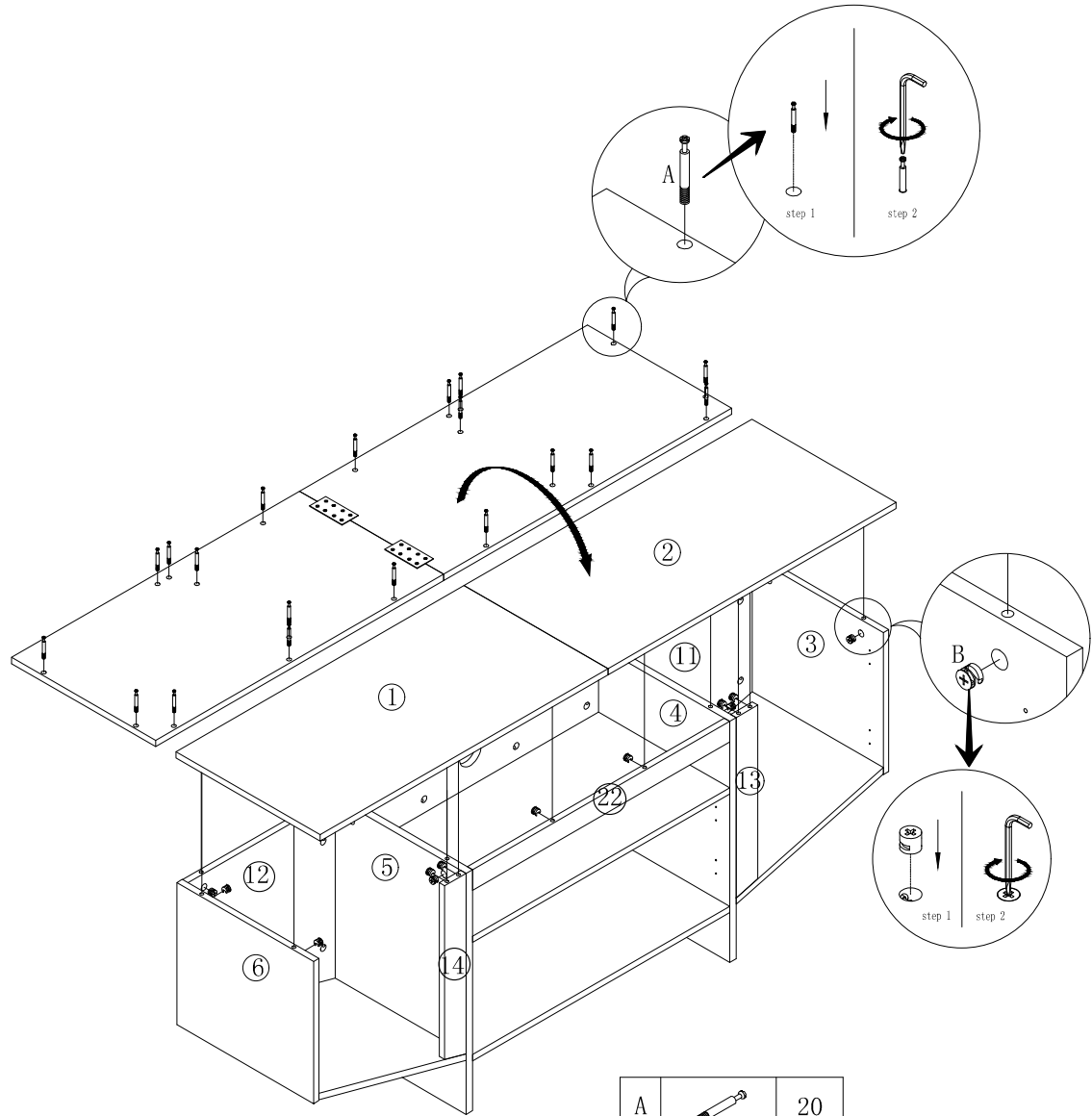

G	 3.5*14mm	16
J	 90*45mm	2



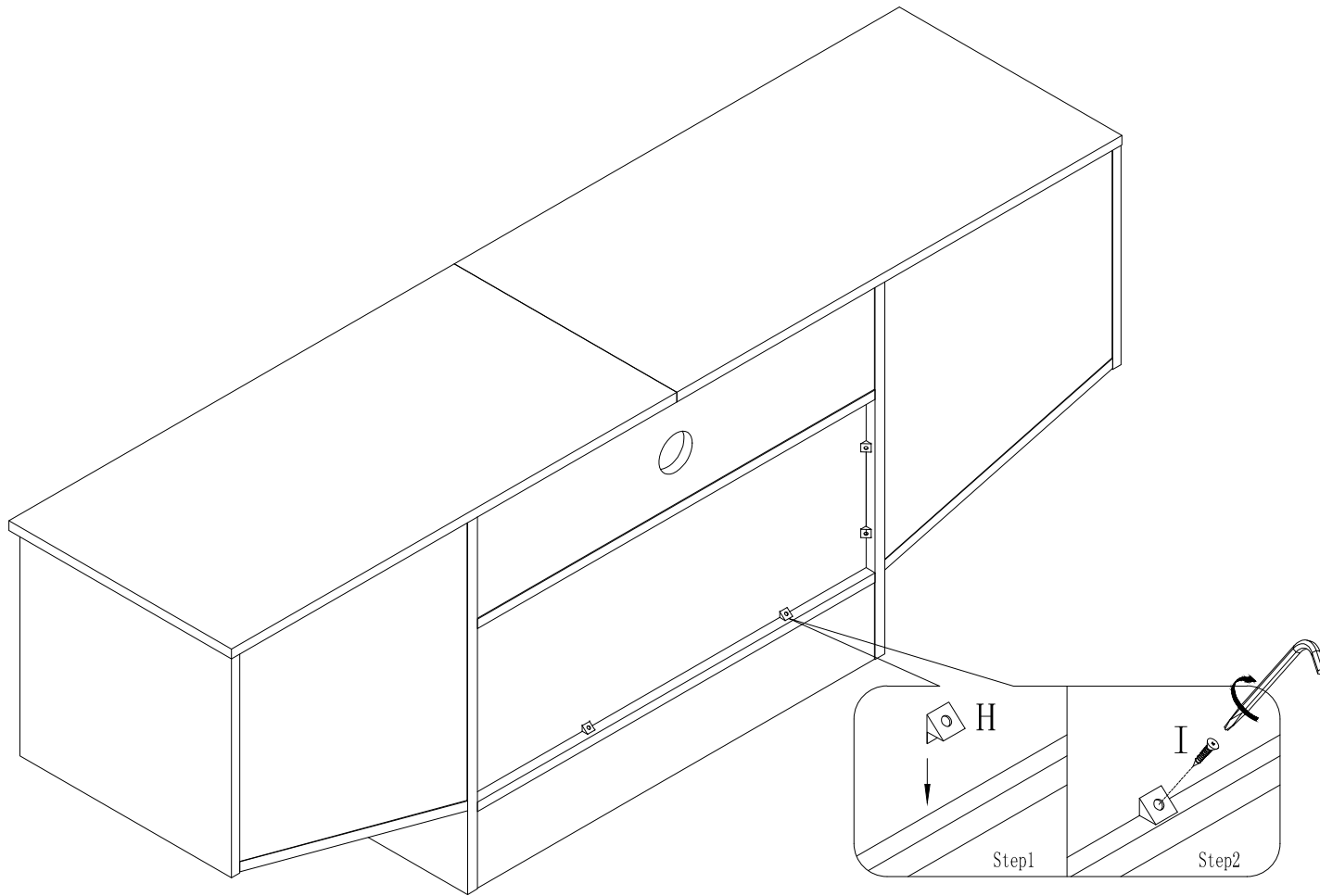

A		20
B		20



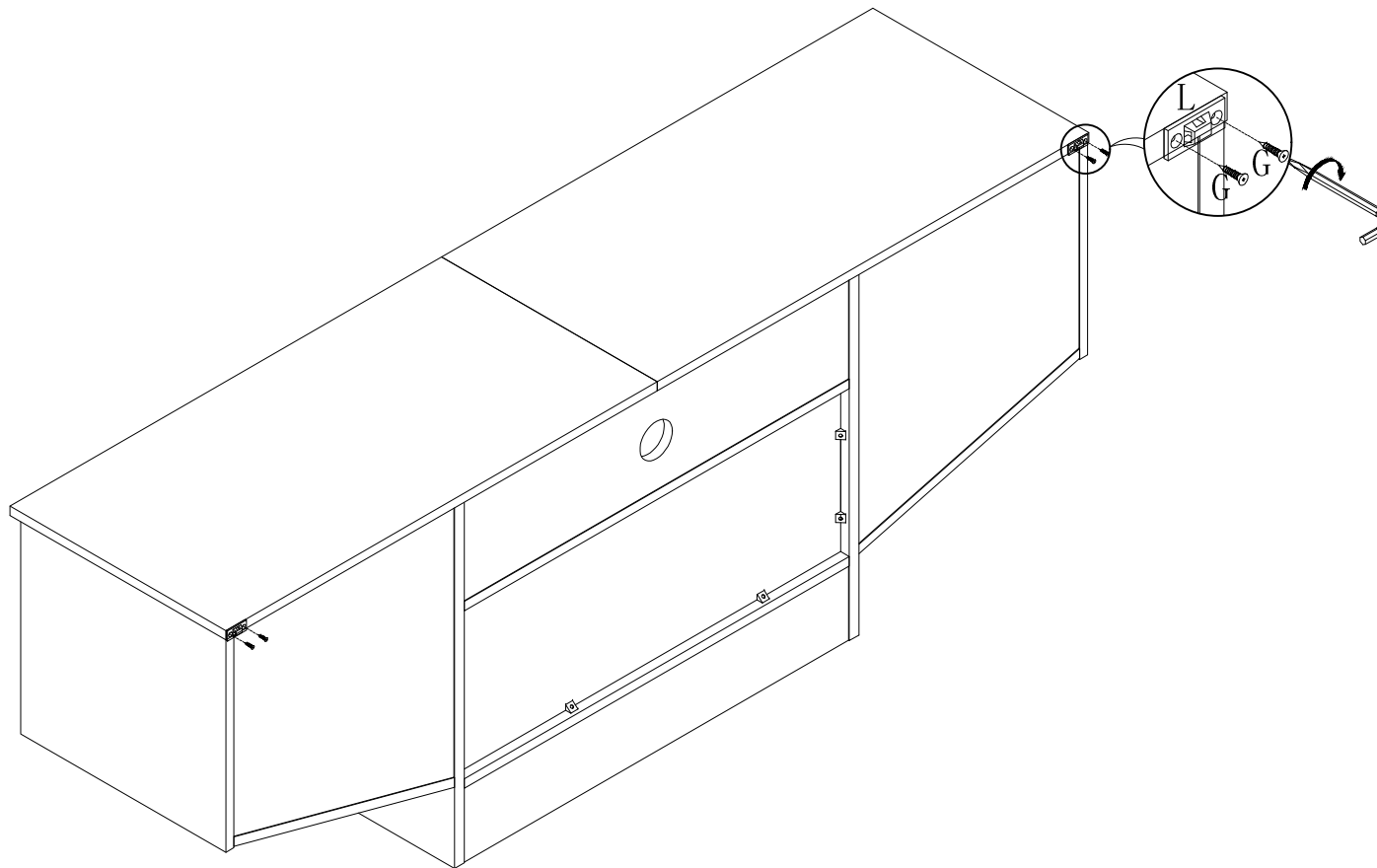

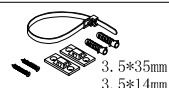
H		8
I	 3.0*14mm	8

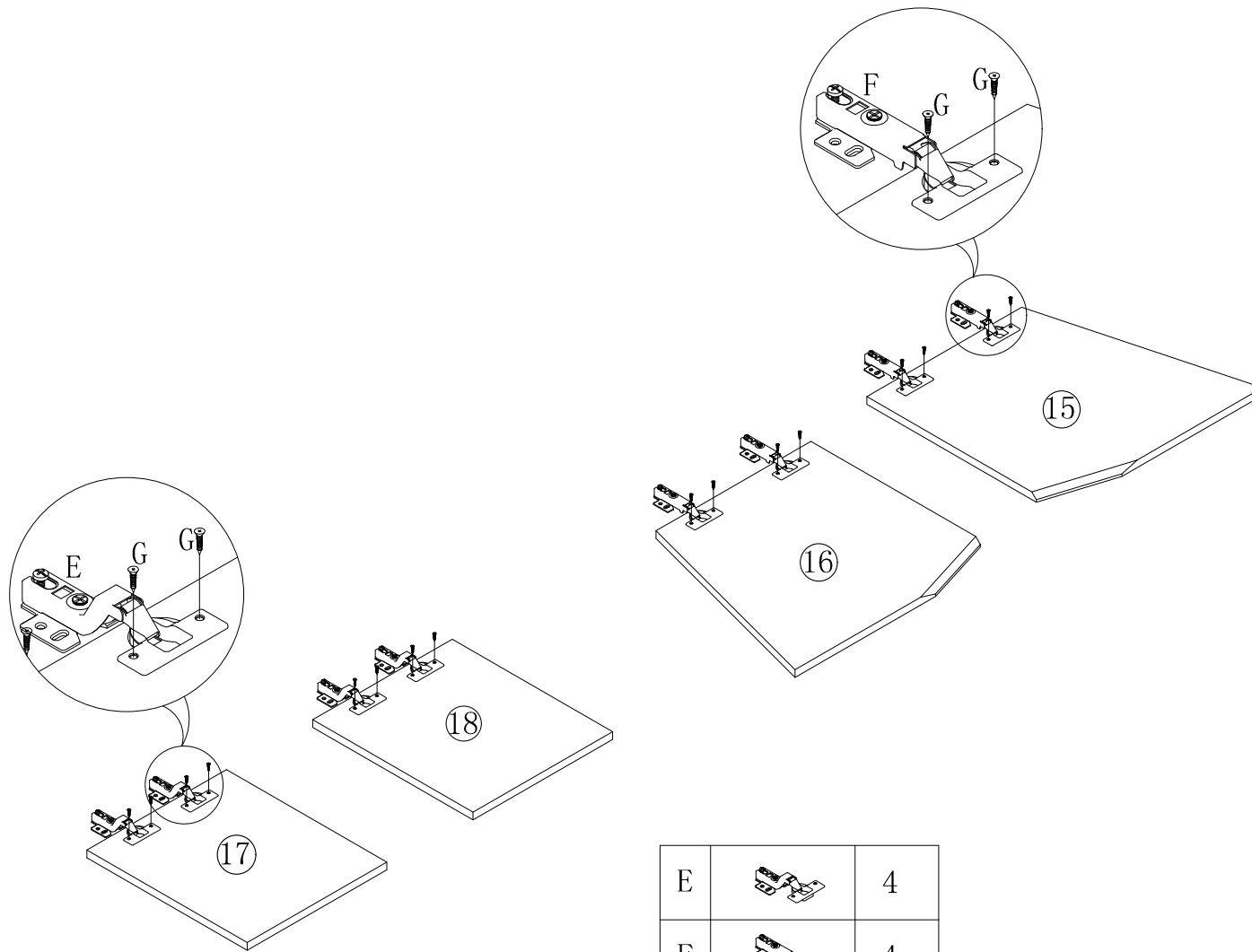

L	 3. 5*35mm 3. 5*14mm	2
G	 3. 5*14mm	4



E		4
F		4
G	 3.5*1.4mm	16

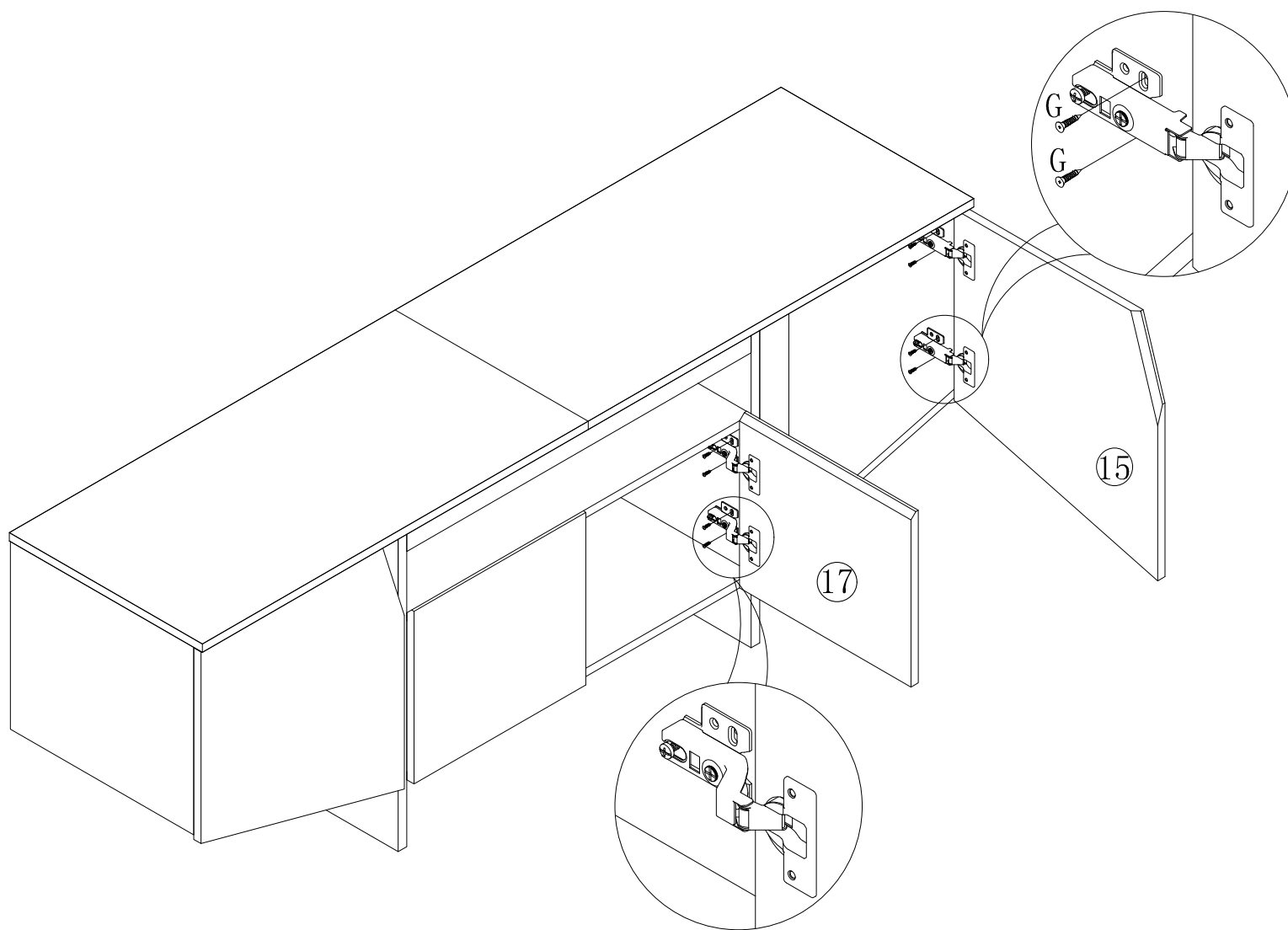

G	 3.5*14mm	16
---	---	----

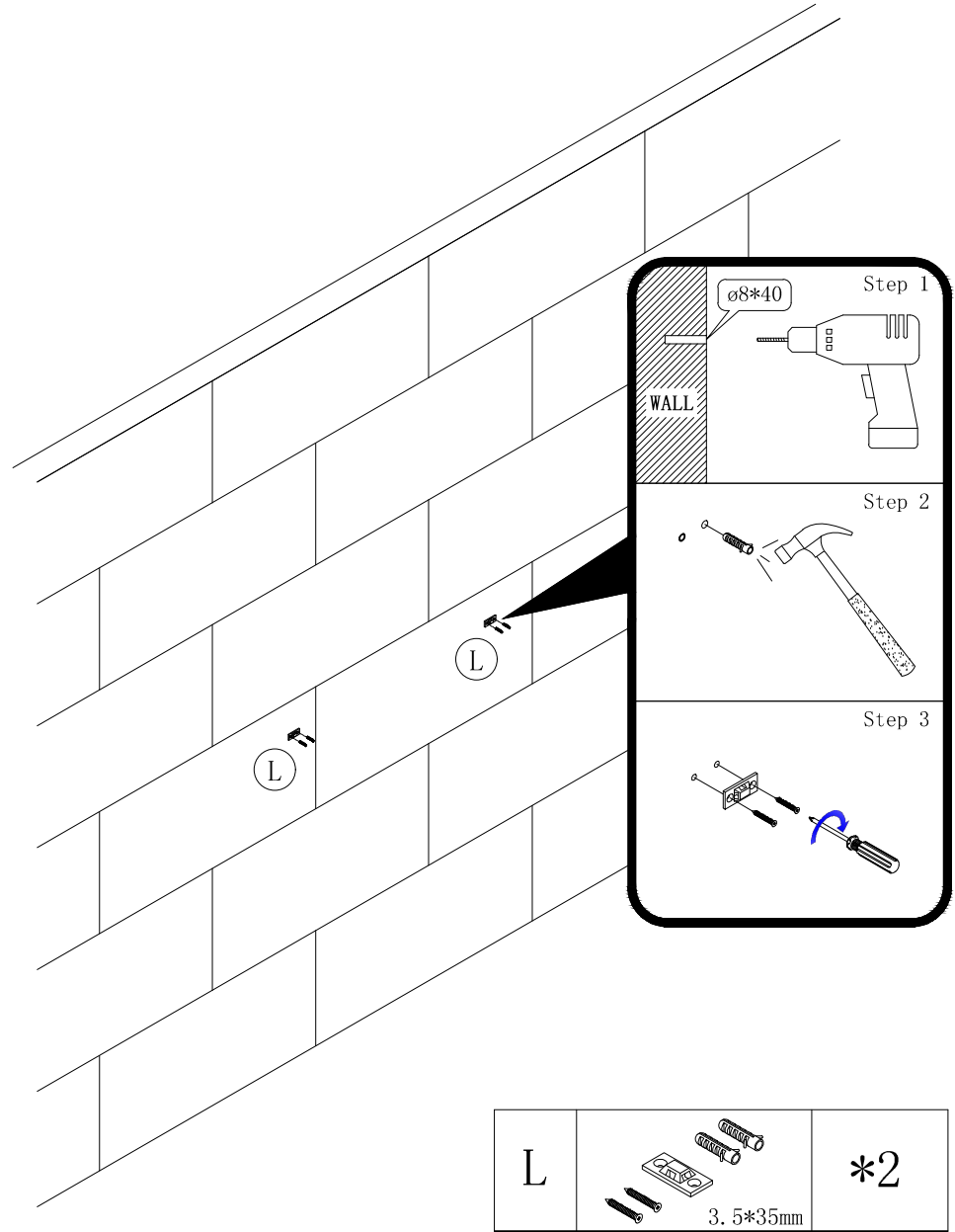

Step 1

ø8*40

WALL

Step 2

Step 3

L	<p>3.5*35mm</p>	*2
---	-----------------	----

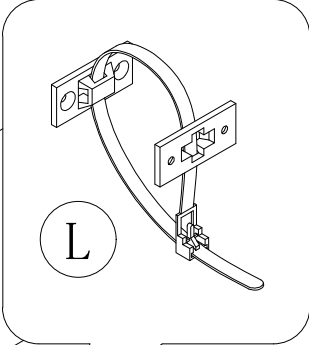
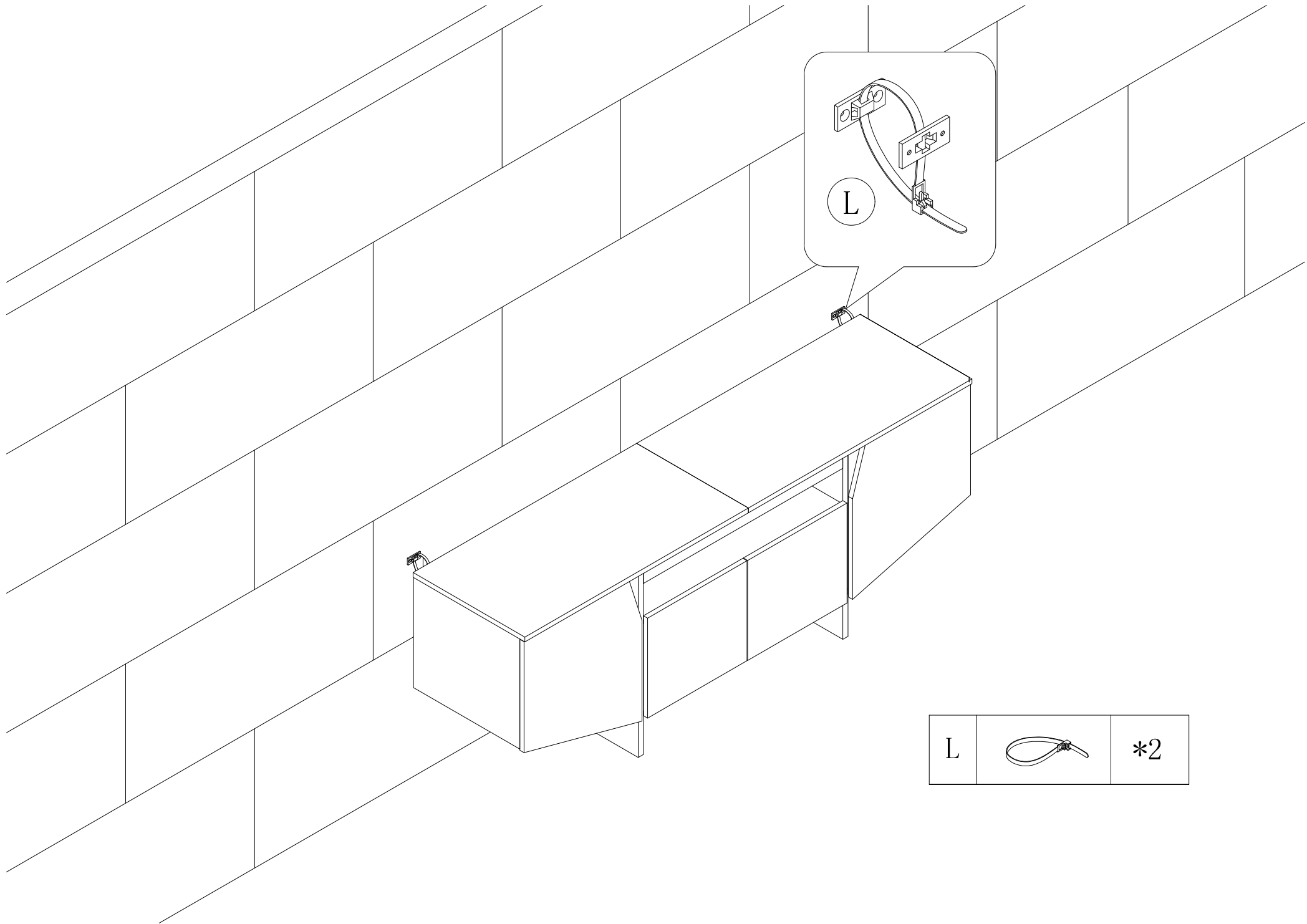

L

L		*2
---	---	----