

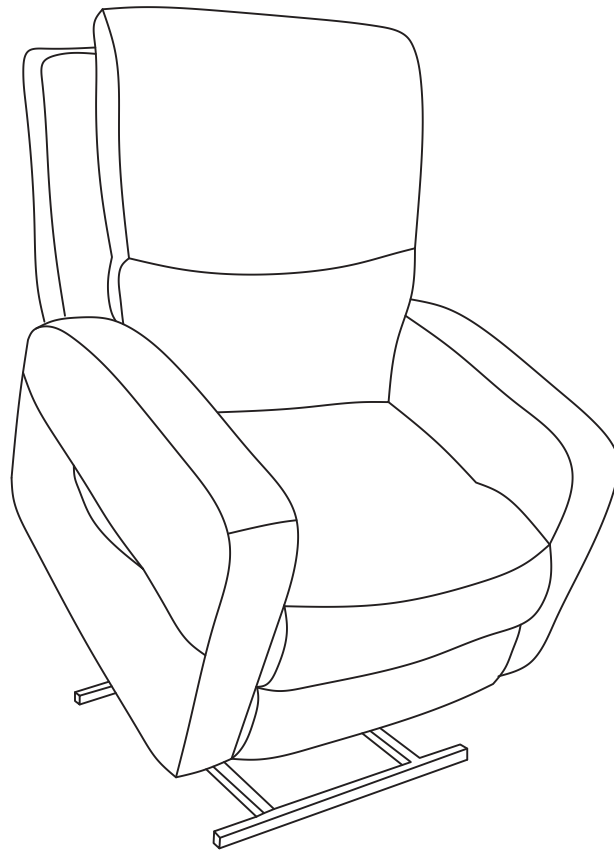

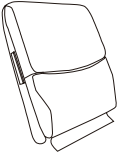

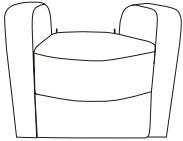



Assembly Manual

Power Lift Chair with Massage

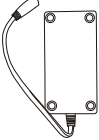

Count parts before assembling.



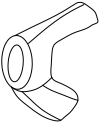
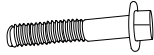



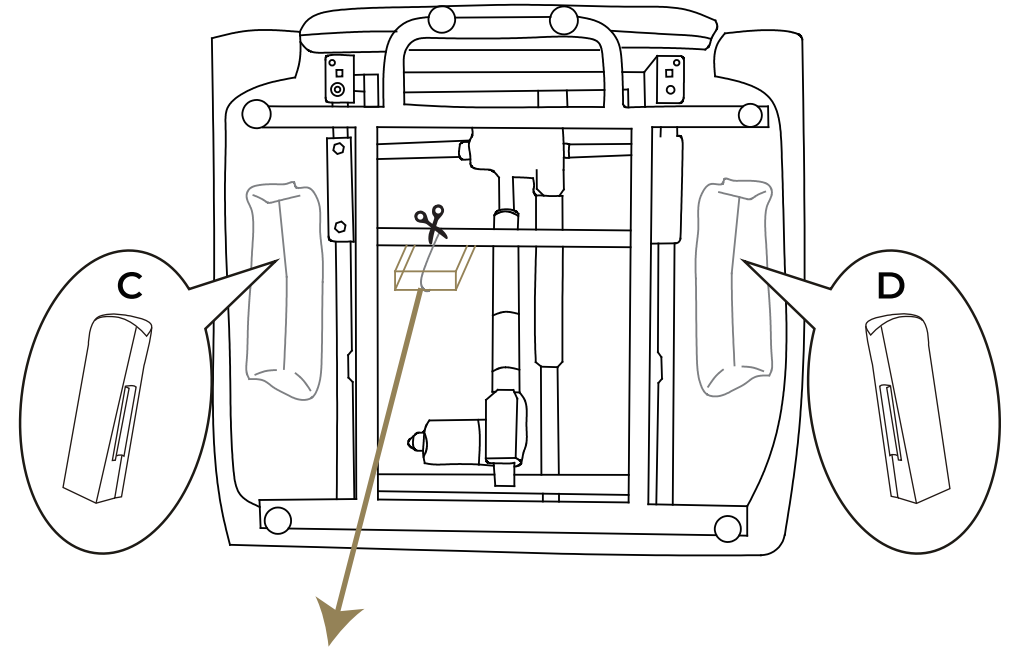

A	1pc	B	1pc	C	1pc	D	1pc
							
Backrest		Seat		Left Side Panel		Right Side Panel	

E	1pc	F	1pc	G	1pc	H	1pc
							
Remote Control for Lifting & Reclining		Remote Control for Massage		Power Adapter		Power Cord for Massage	
I	1pc	J	2pc	K	4pc	L	4pc
							
Power Cord for Adapter		Foot		Butterfly Nut		Bolt	

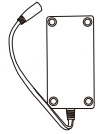
Step 1

Flip the chair to take out Left Side Panel and Right Side Panel from the bottom of Seat. Cut the plastic ties to take out the hardware pack (Includes: Remote Control for Lifting & Reclining, Remote Control for Massage, Power Adapter, Power Cord for Massage, Power Cord for Adapter, 2 pieces of Feet, 4 pieces of Butterfly Nuts, 4 pieces of Bolts).



- | | | | | | | | |
|----------|---|----------|---|----------|---|----------|---|
| E |  | F |  | G |  | H |  |
| | Remote Control for Lifting & Reclining(x1) | | Remote Control for Massage(x1) | | Power Adapter(x1) | | Power Cord for Massage(x1) |
| I |  | J |  | K |  | L |  |
| | Power Cord for Adapter(x1) | | Foot(x2) | | Butterfly Nut(x4) | | Bolt(x4) |

Step 2

Locate the four holes at the back of the seat base and attach the feet(J) using Bolts(L) and Butterfly Nuts(K). Fully tighten.

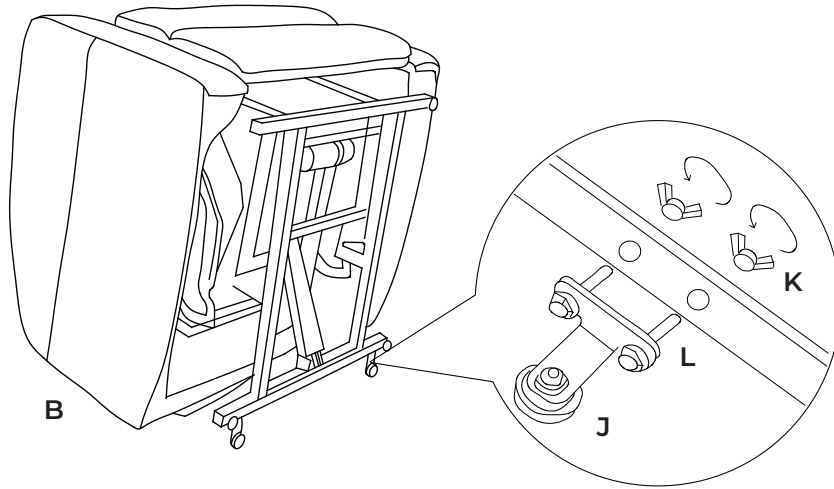

Step 4

Slide the backrest into the metallic quick connectors of the seat. Push down the back firmly until each side is locked into place and an audible "click" is heard.

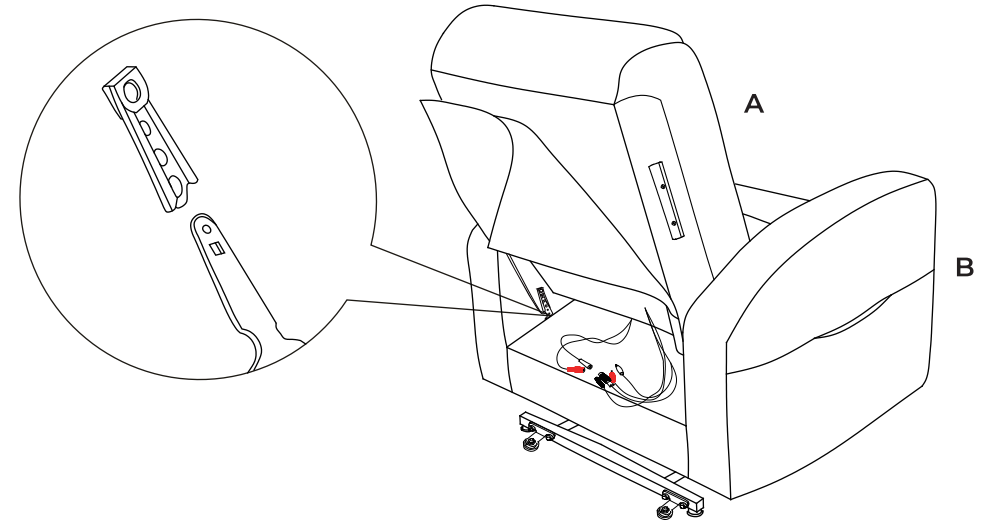

Step 3

Zip up the bottom of the backrest the seat together.

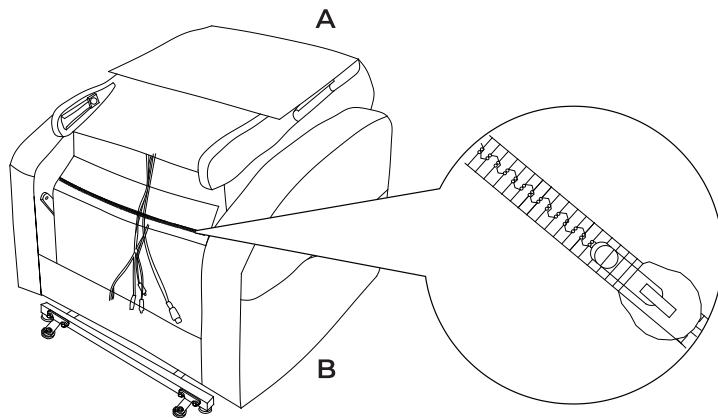

Step 5

Slide Left Side Panel(C) and Right Side Panel(D) into Backrest(A).

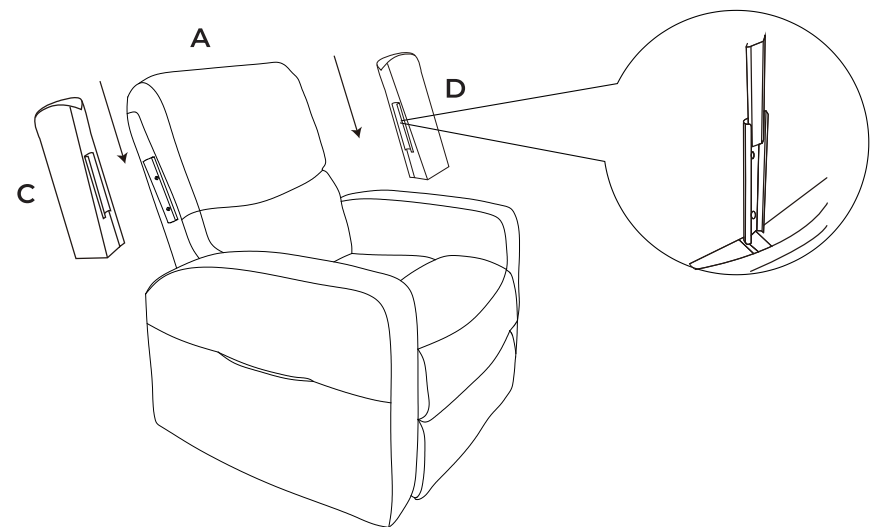

Step 6

Connect the white and red wires from the backrest to the corresponding wires on the seat. Make sure the corresponding colors match (white with white & red with red).

Locate the Remote Control for Massage(F) and connect to its corresponding receiver on the backrest. Make sure the corresponding sizes match.

Locate the Power Cord for Massage(H) and connect to its corresponding receiver on the backrest. Make sure the corresponding sizes match.

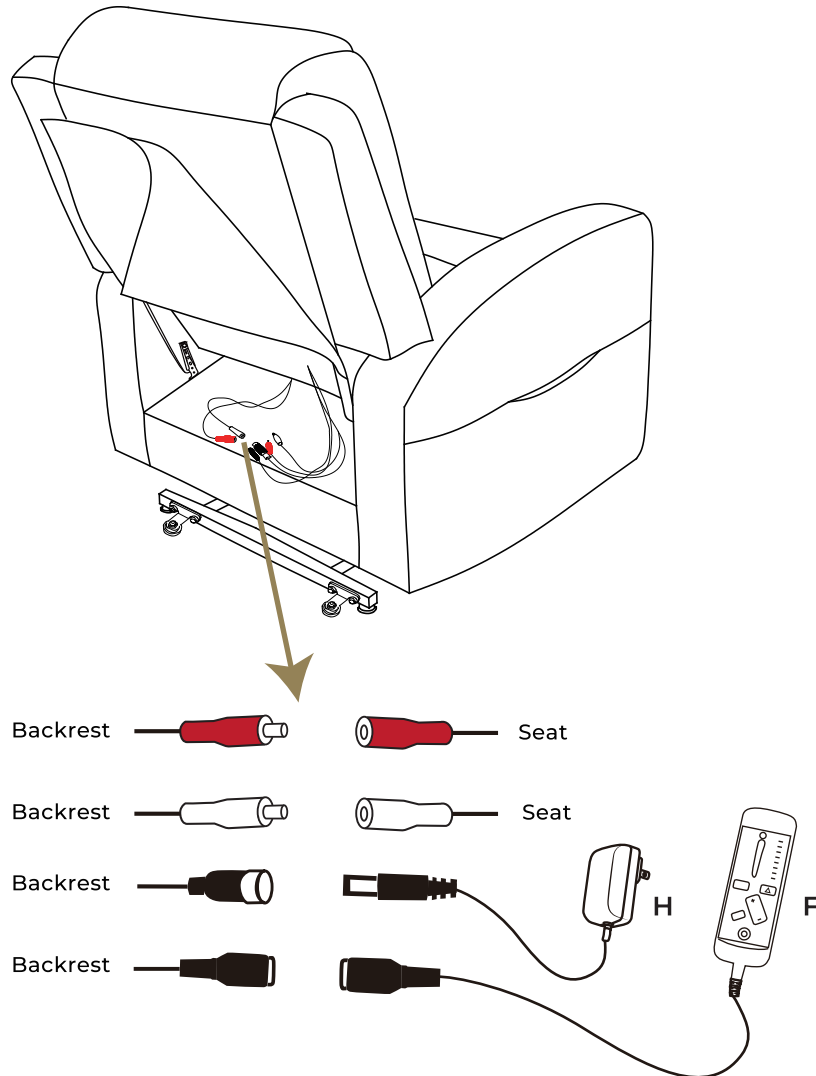

05

Step 7

Locate the Remote Control for Lifting & Reclining(E) and connect to its corresponding receiver on the base of the seat.

Locate the Power Adapter and connect to its corresponding receiver on the base of the seat.

Connect one end of the Power Cord for Adapter(I) into the Power Adaptor(G).

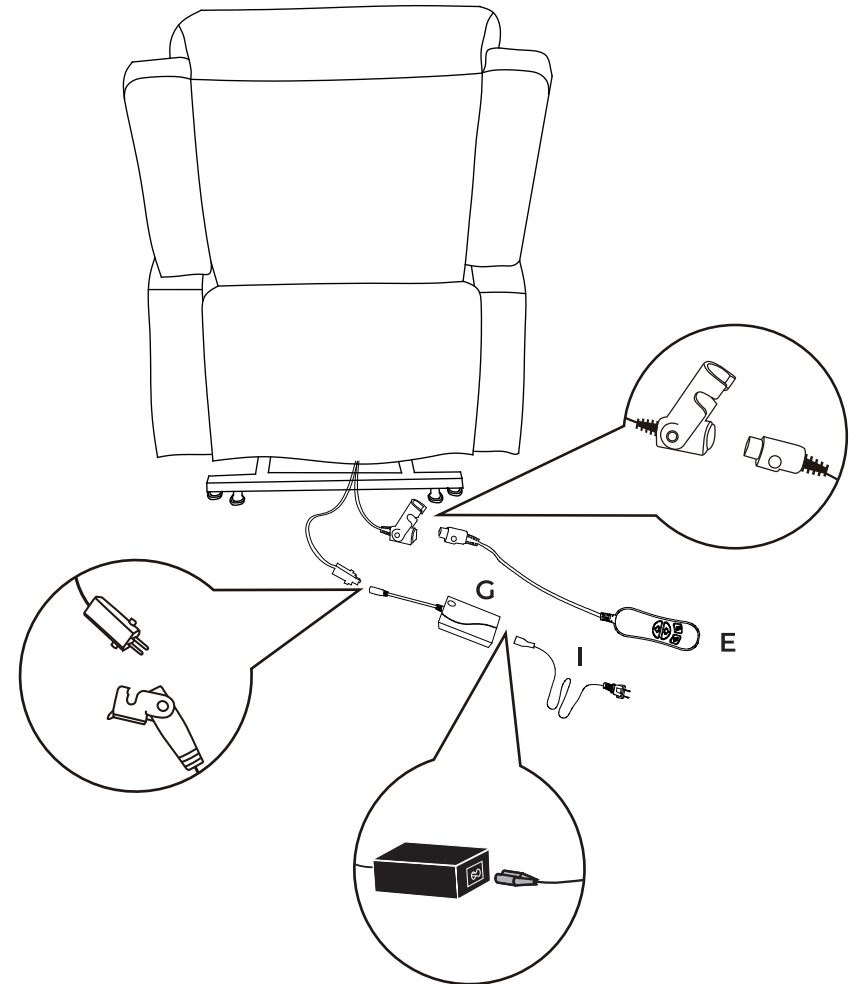

06

Step 8

Attach the back cover to the bottom of the seat with Velcro.

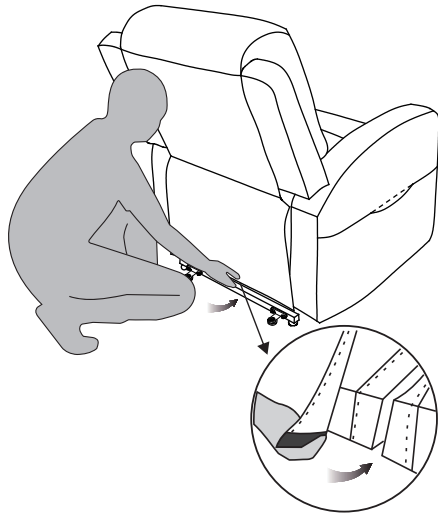

Step 9

Plug Power Cord for Adapter into the power outlet.

Note: After all the connections are made, the green LED will be lit up.

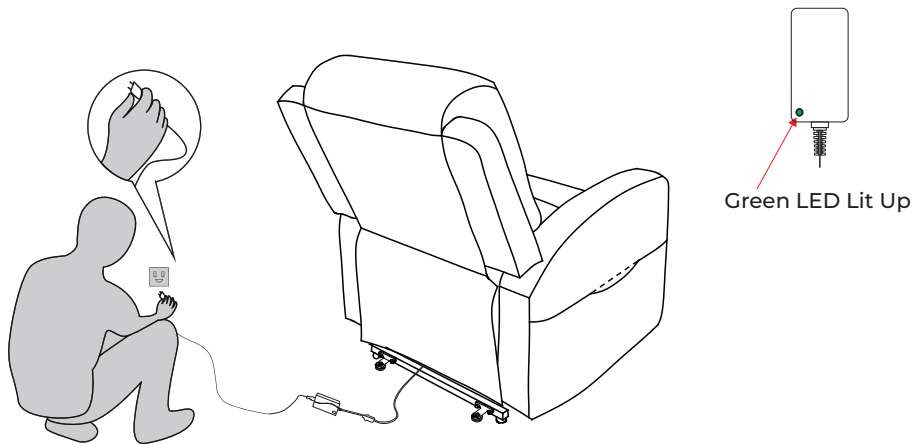

07

How to Operate

Remote Control for Lifting & Reclining

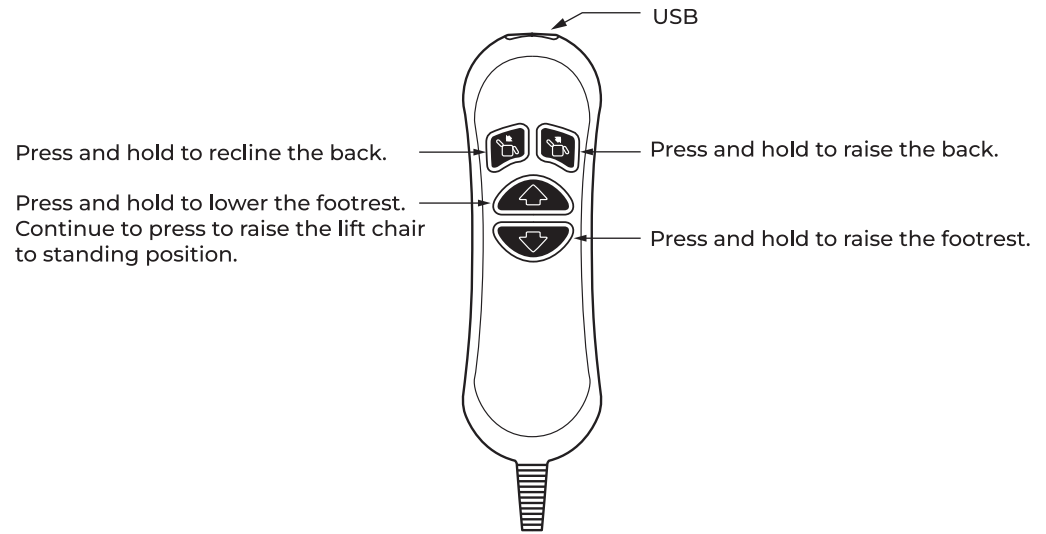

Remote Control for Massage

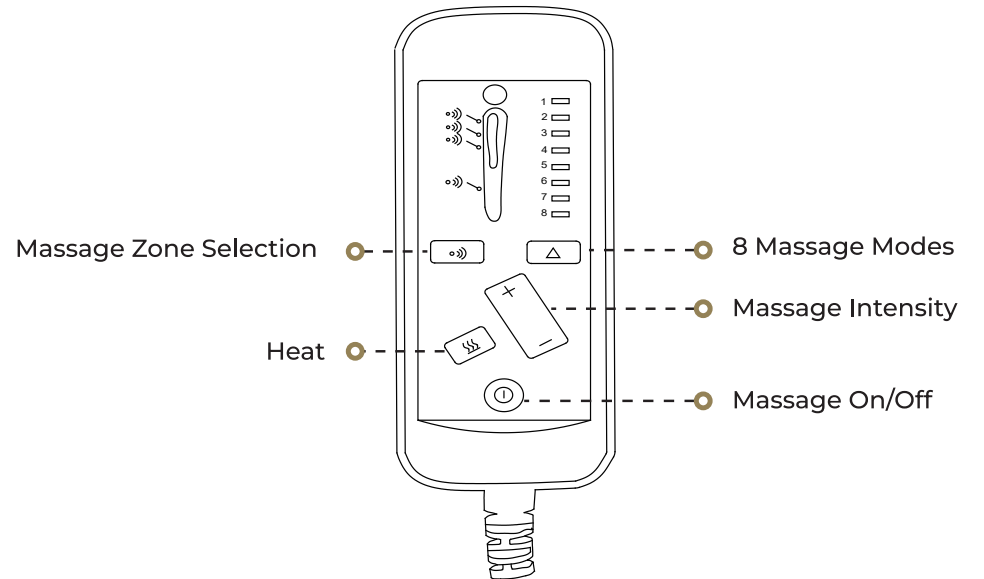

08