

OWNER'S MANUAL

**SMALL POWER LIFT
RECLINER**

Hello,
Thank you for choosing
Let's get started

○ PURCHASER'S AGREEMENT

By accepting delivery of this product, you promise that you will not change, alter, or modify this product or remove or render inoperable or unsafe any guards, shields or other safety features of this product.

You will not refuse or neglect any retrofit kits that we may provide to enhance and preserve the safe use of this product.

CONTENTS

I	SAFETY GUIDELINES	- 01	VI	DISASSEMBLY INSTRUCTION	- 23
	<ul style="list-style-type: none">• Mandatory• Danger• Warning• Symbols information• Disclaimer			<ul style="list-style-type: none">• Disconnect all Connections• Disassemble Backrest• Disassemble Armrests	
II	ASSEMBLY INSTRUCTIONS	- 04	VII	WARRANTY	- 25
	<ul style="list-style-type: none">• Product Parameters• Part List• Assembly Steps				
III	OPERATING INSTRUCTIONS	- 11	VIII	RETURN / REPLACEMENT POLICY	- 26
	<ul style="list-style-type: none">• Operation Precautions• Lift Remote Operation Instruction• Massage Remote Operation Instruction				
IV	CARE AND MAINTENANCE	- 14	IX	CUSTOMER SUPPORT	- 27
	<ul style="list-style-type: none">• Fabric Care• Faux Leather Care• Electronics Care• Disposal & Recycling				
V	TROUBLESHOOTING	- 16	X	VOICE OF CUSTOMER	- 28

I. SAFETY GUIDELINES

1. Mandatory

Read the safety and other instructions thoroughly before using your product. Failure to follow the guidelines, warnings in this manual and those located on your product can result in personal injury or product damage and will void the product warranty. Keep this manual for future reference.

2. Danger

- To prevent suffocation, keep plastic bags away from children.
- Do not allow children to play on or near the chair when in use. Serious injury or death could occur if a child is under the chair when the chair is in motion.
- Keep cord out of reach of small children, and do not use where it may be a trip hazard.
- Plug directly into a wall outlet. Do not use an extension cord or adapter.
- Do not use this product if it is wet, in water, around water or any liquid.
- Always leave in an upright and closed position. Keep hands and feet clear of mechanism and all moving parts. Footrest must be completely closed before getting in or out of the chair. Only the occupant should operate the chair.
- Before moving or troubleshooting, unplug power cords from outlet and secure the mechanism to prevent unexpected movement of the chair.

3. Warning

- Weight Capacity: 320 lbs.
- Do not use outdoors. INDOOR USE ONLY.
- To avoid tip over, do not put your weight against the back of the chair.
- Do not stand, sit, or place extra weight on the arms, back or open footrest.
- Do not use this product if it is damaged. Do not use attachments or substitute parts.
- Avoid exposing upholstered chair to burning cigarettes or cigars, open flames, and high temperatures.

- Do not operate the unit until the back is installed and locked.
- Do not attempt to disassemble or repair the actuator or pump; no serviceable parts are inside.
- Do not allow electrical cord to be pinched between moving parts or between the frame and the floor. Do not place cord under carpet or in a location where it could become worn.
- Do not attempt to disconnect the power plug by pulling the power cord. Always hold the power plug and pull it out.
- Closely supervise children and disabled persons using this product.
- To reduce the risk of head entrapment and other injuries, keep children and pets away from openings and moving parts in and around furniture.
- This product has many moving parts, serious injury can occur if not used properly. Keep hands, fingers, and body parts away from the mechanism.
- To exit the unit safely and prevent a tripping hazard, bring the back upright and close the footrest.
- Place tables and area rugs at a distance to allow the footrest to fully extend without rubbing or interference.
- Check the condition of the power supplies, electrical cords, plugs, and connectors often. Keep the power supplies and electrical cords away from heat sources. Never operate the unit with a damaged power supply, electrical cord, plug or connector.
- Do not charge your device into the USB charge ports over 24hours.
- Do not charge any devices over 5V/2A with the USB charge ports.
- Do not overlay the USB charge ports with other heat-dissipating electronic products. This may prevent heat dissipation and cause overheating or melting.
- Unplug the power cord immediately if you detect strange odors or fumes coming from the chair. Contact your Customer Support.
- The chair is intended for a single occupant, not exceeding 320 pounds. Do not operate the chair with more than one occupant in or on any part of the chair.
- If you give this product to someone else, must include this owner's manual.

4. Symbols Information

The symbols below represent labels used on the product to identify warnings, mandatory actions, and prohibited actions. It is especially important for you to read and understand these symbols completely. Do not remove these labels from your product. Please note that not all the symbols may be used on your chair.

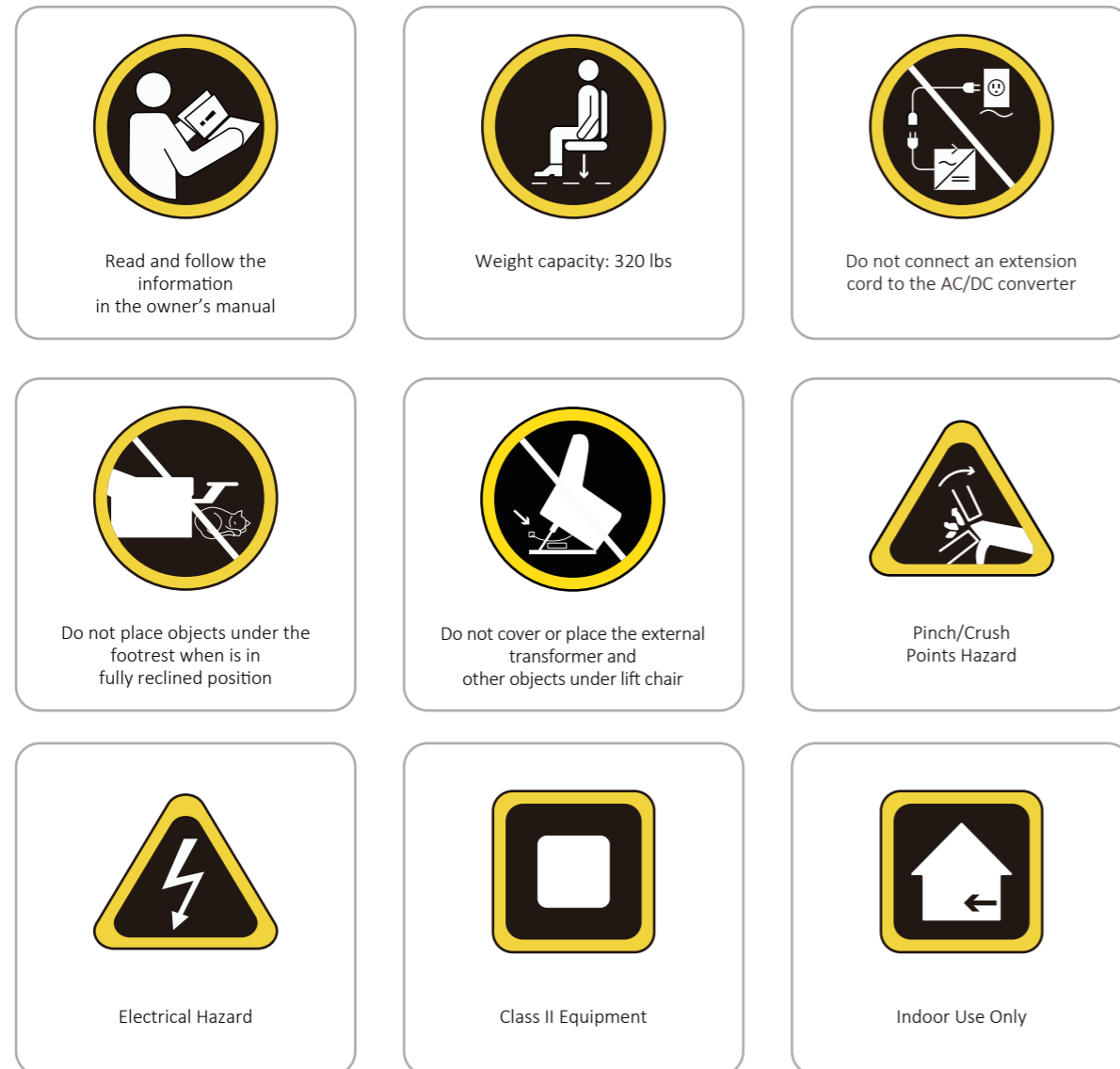

5. Disclaimer

Make sure you read and understand this manual completely before using your Product. We are not and cannot be held responsible for any damage or injury incurred due to improper or unsafe use of the Product. We specifically disclaim responsibility for any bodily injury or property damage that may occur during any use that does not comply with applicable federal, state, or local laws or ordinances.

II. ASSEMBLY INSTRUCTIONS

■ Notice

- Please read these instruction thoroughly before using.
- Do not plug the power supply in until assembly complete.
- Choose a location for the lift chair that is close to an electrical outlet (1 power outlet required).

1. Product Parameters

Specification		Description	
Rated Voltage		100~240V	
Rated Current		1.5A	
Out put Voltage		29V	
Overall Dimension		31.5*35.4*42.1 inch	
Reclining Angle		140°	
Weight Capacity		320lbs	
Package Quantity		2	
USB power specifications	Voltage	5V	
	Power	Single	10W
		Dual	5W

2. Part List

● Notice

- Use our parts only for all replacements.

Box 1 of 2

A Base x1

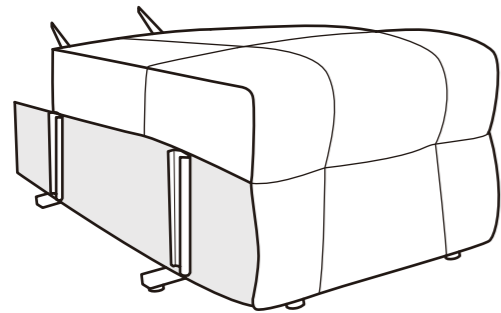

C1 Right Armrest with USB x1



Box 2 of 2

B Backrest x1

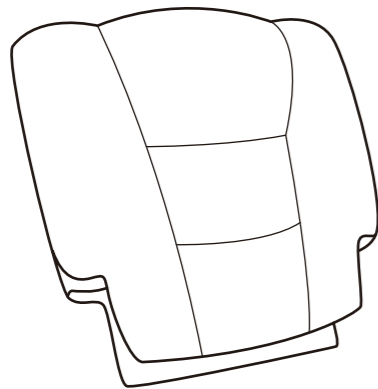

C2 Left Armrest x1

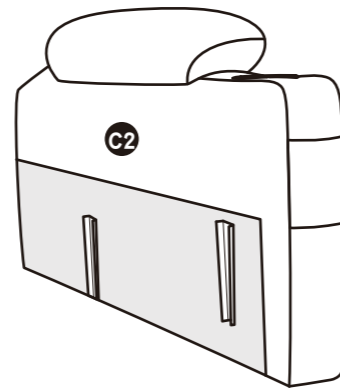

D Parts Box

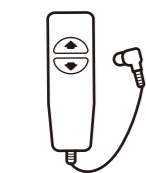

Lift Remote x1

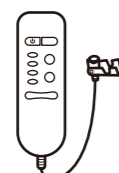

Massage Remote x1

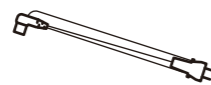

Angle Power Cord x1

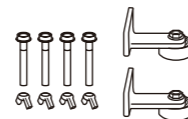

Anti-back-tipping x2



Rack circular gasket x2
(Spare parts)

3. Assembly Steps

Step1 - Armrest Assembly

1. Ensure the armrest which has USB charge port is located on right of base.
2. Slide the left and right armrest into the brackets of the base.
3. Press each armrest down as far as it will go (Figure).

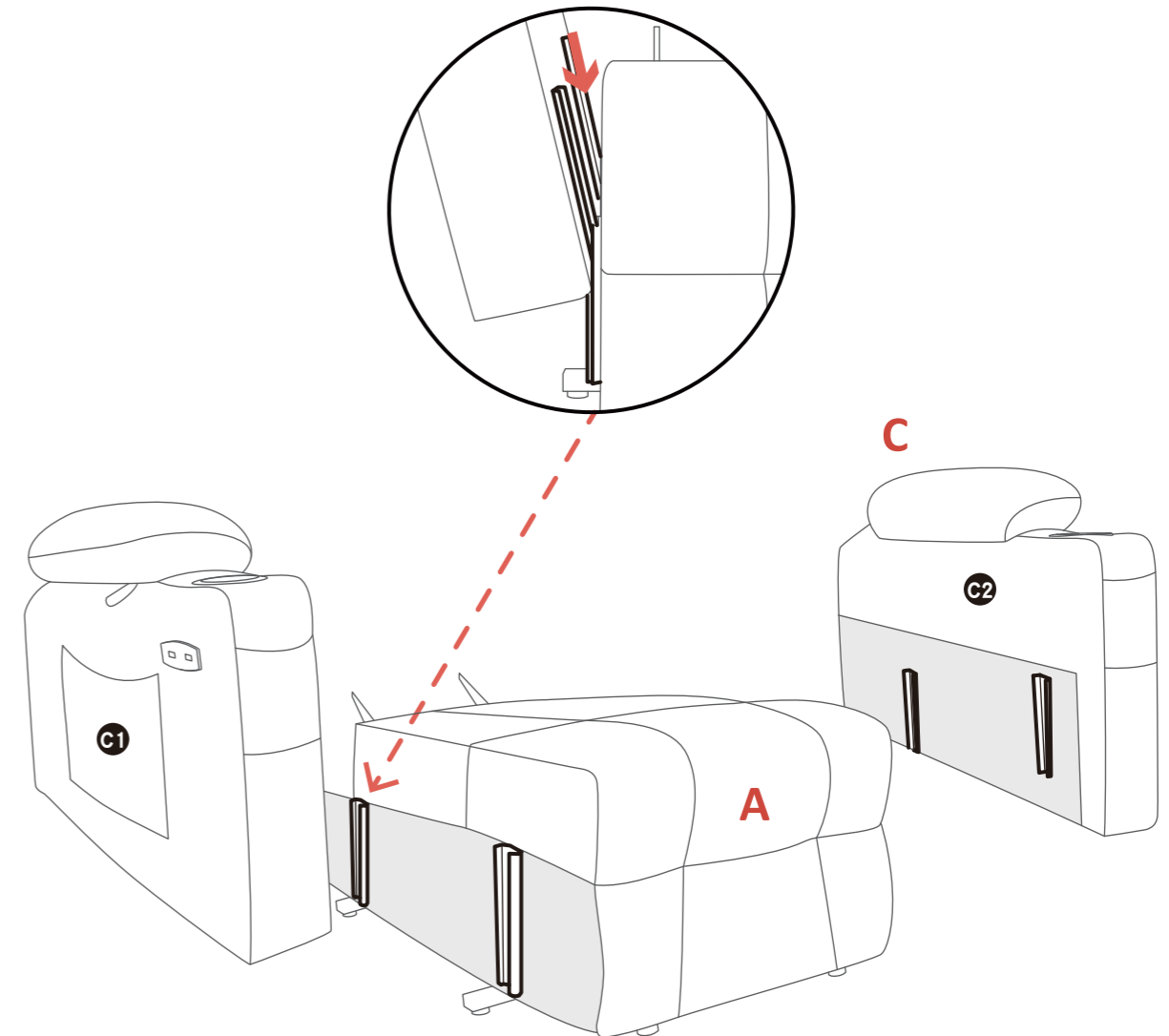

ATTENTION

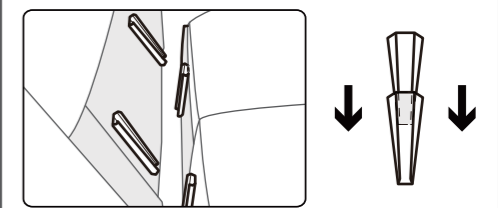

Ensure the two connections on each armrest are all inserted into the seat tightly.

NOTE: Ensure the two connections on each armrest are both inserted into the seat tightly.

Step2 - Backrest Assembly

1. Align the brackets of backrest at the clips of seat-back (Figure).
2. Push the brackets into the seat-back tightly. Listen for a “click” sound on each side to ensure the backrest is locked in properly.

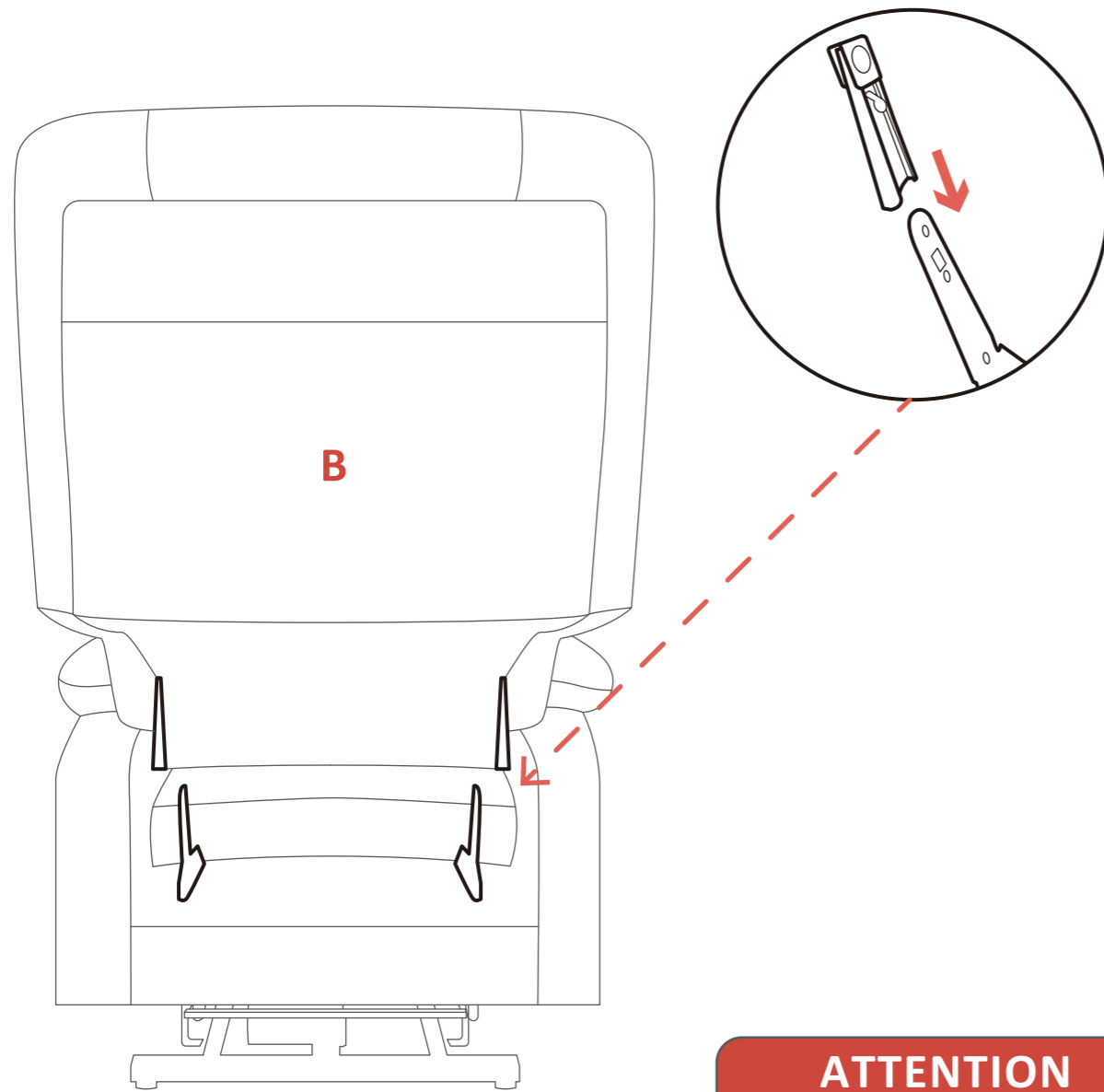

NOTE: Pull up the backrest to check if it is locked in place.

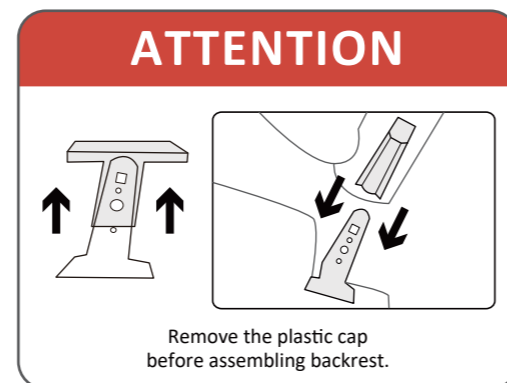

Step3 - Lift Connections

1. Connect the chairs according to the following wiring diagram (Figure).
2. Attach the chair-back to the velcro on the bottom of the chair base.

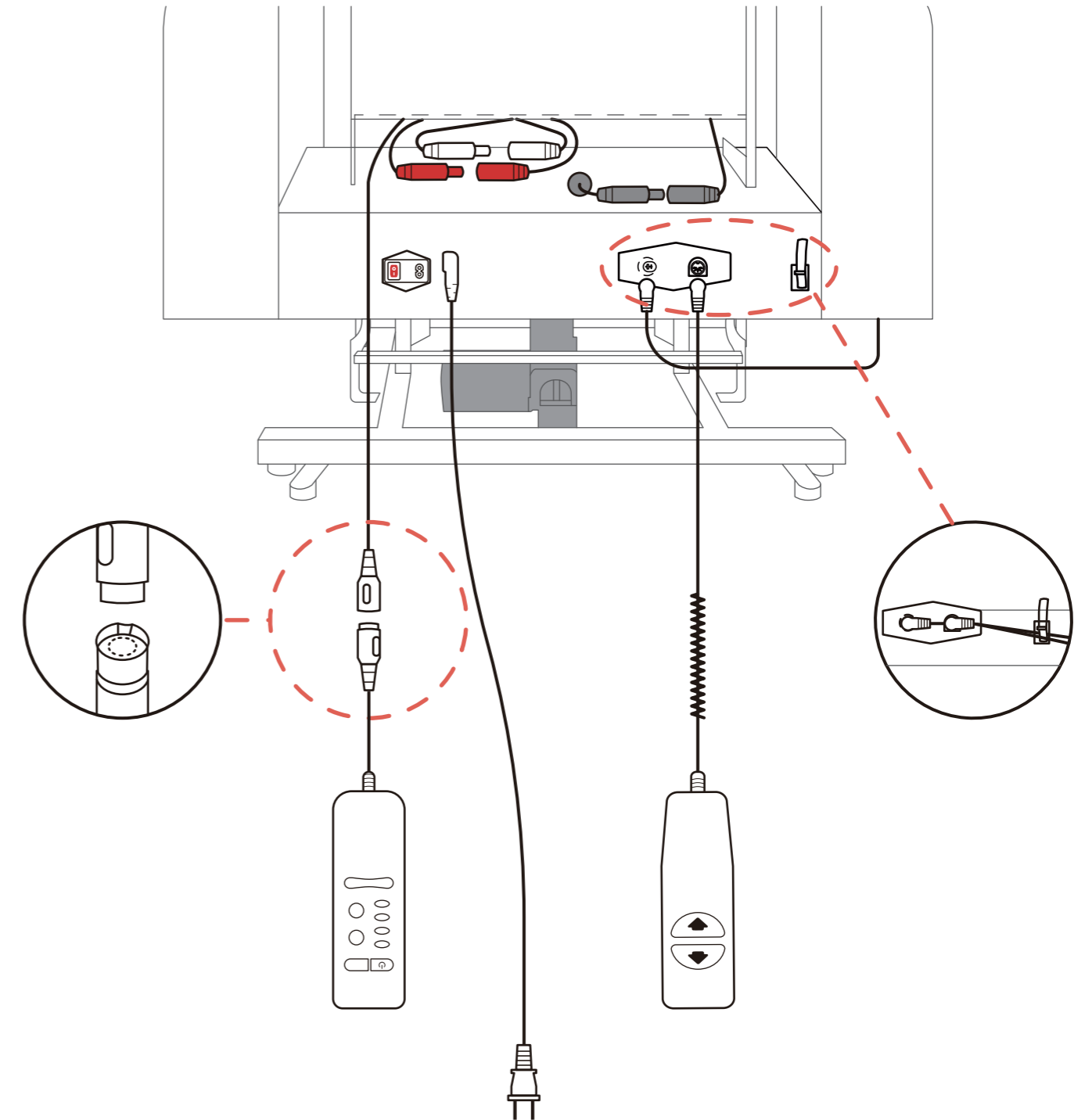

Step4 - Anti-back-tipping Part Assembly

1. Place the Anti-back-tipping parts (D) near the bottom of base.
2. Align the screws with the holes then tighten the wing screws (Figure).

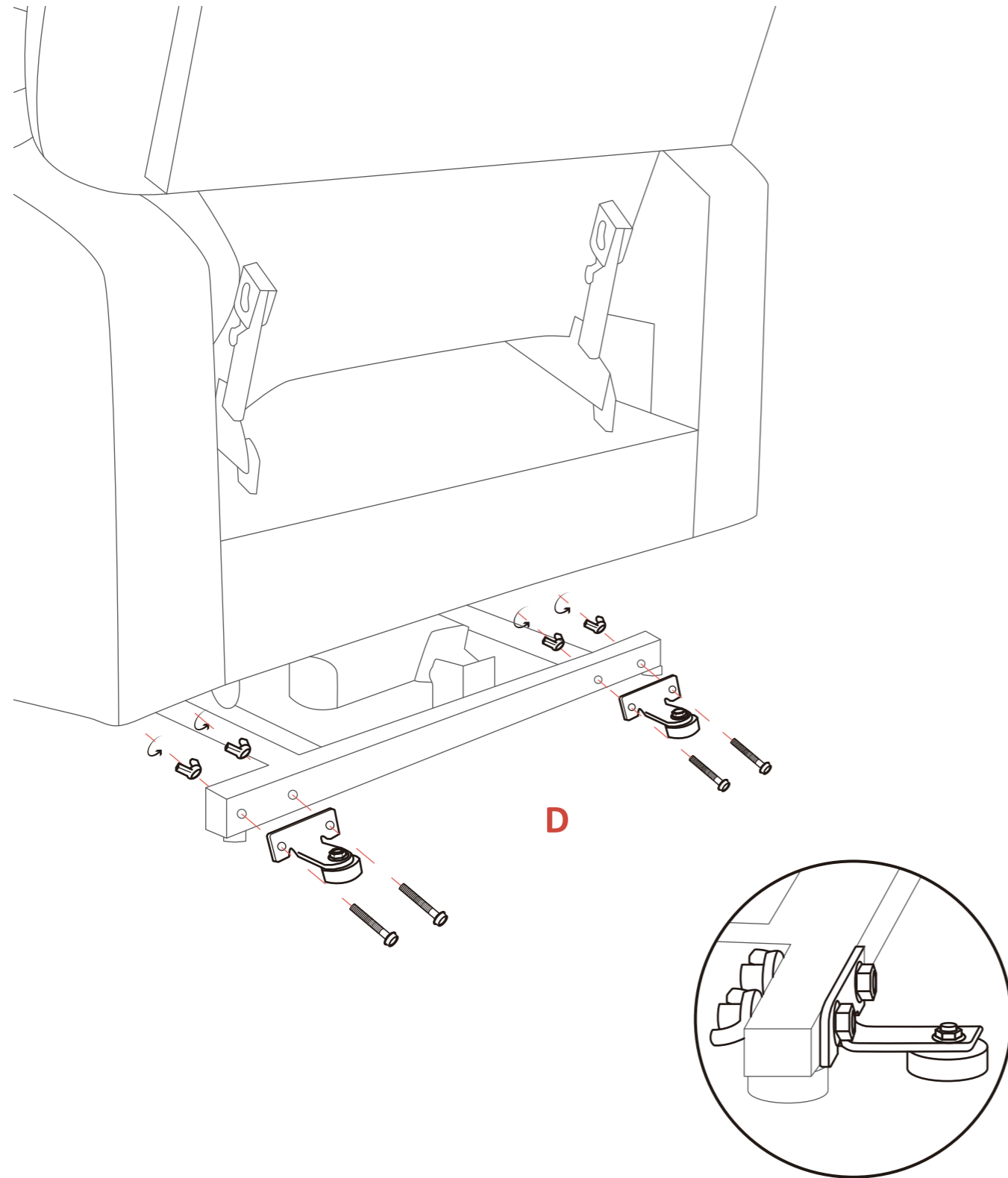

Step5 - Final Check

1. Make sure both metal brackets on each armrest are mounted on the base.
(There are two metal brackets on each side of the base, it looks like assembly finished when you insert armrest into only one bracket instead of two, however all pressure will apply to one bracket, that is one likely reason that the armrest fall apart from the seat.)
2. Make sure the backrest inserts are locked to the base.
(Pull up the backrest to check if it is locked in place.)
3. Make sure all wires are connected tightly.
4. Make sure all wires are not placed on the bottom of the rack and will not be pressed by frame.
(If the wire is pressed by the frame, the wire will be broken by the frame and the chair will stop working.)
5. Make sure the anti-tilt fitting screws are tightened.

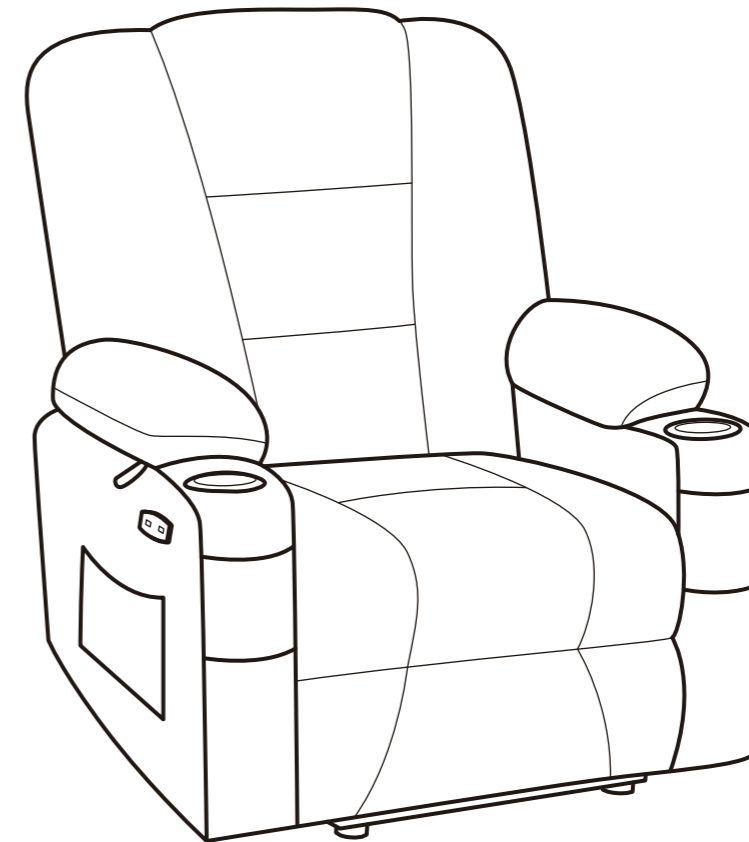

III. OPERATING INSTRUCTIONS

1. Operation Precautions

- Do not use an extension cord.
- Do not exceed recommended weight limit.
- Do not use attachments not recommended by the manufacturer.
- Do not use outdoors. INDOOR USE ONLY.
- Stay away the backrest from wall at least 16 inches before using.
- Use this lift only for its intended use as described in the operating.
- Keep dry. Do not operate in a wet or moist environment.
- Keep all cords away from heated surfaces and pinch points.
- Ensure the hand control is out of the way before sitting in the chair.
- Always leave the lift chair in an upright and closed position when not in use.
- Periodically check the hand control and all power cords for visible damage.
- Do not use the footrest as a seat, or for purposes outside its intended use.
- Do not lean or apply downward force to the chair-back while in recline position.

NOTE:

If you discover a problem at any point during the setup and positioning of your lift chair, stop and contact the Customer Support immediately. To avoid personal injury and/or product damage, do not plug the unit into the electrical outlet until the problem is corrected and do not attempt to fix electrical problems by yourself.

2. Lift Remote Operation Instruction

^ LIFT (UP)

Press and hold the UP button to raise the chair to the full-lift position.

Press and hold the UP button to return to the seated position from the reclined position.

∨ LIFT (DOWN)

Press and hold the DOWN button to lower the chair to the seated position.

Press and hold the DOWN button to raise the footrest and recline the chair back.

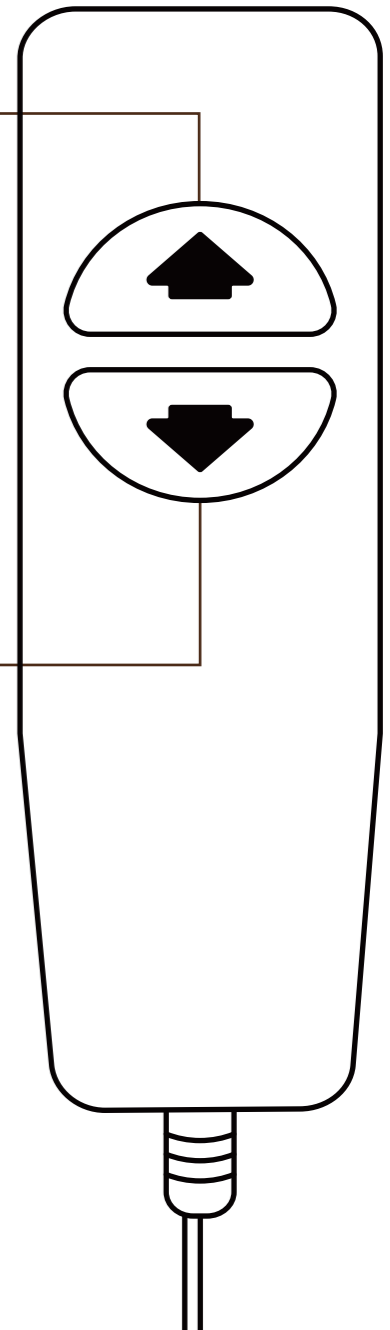

3. Massage Remote Operation Instruction

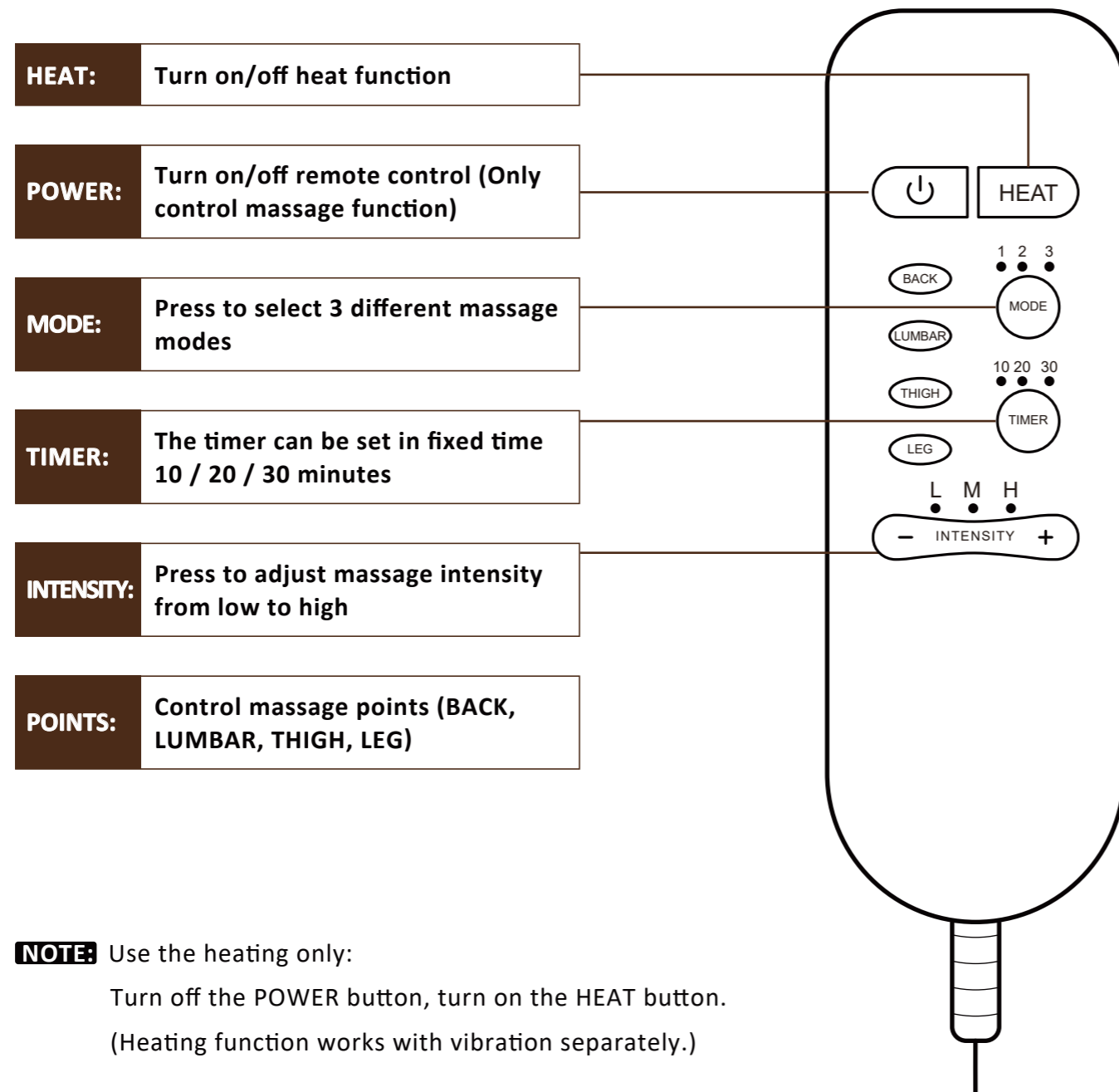

IV. CARE AND MAINTENANCE

Your product will provide years of superior performance and satisfaction with regular care and maintenance. To maintain the finish quality of your "assistant", please follow the guidelines and cleaning procedures provided below.

■ Notice

- Do not place your chair in direct sunlight, as sunlight causes fading.
- Do not smoke cigarettes while sitting in or using your chair.
- Avoid extreme changes in temperature by arranging chair away from radiators, heat and air vents.
- Do not use solvent-type cleaners to spot clean.
- Do not saturate fabric.
- Please be careful that pet scratch may cause fabric or leather break.

1. Fabric Care

- Inspect the fabric on a regular basis for any pulls, tears, or gaps.
- Frequent vacuuming or light brushing with a nonmetallic, stiff bristle brush to remove dust and grime is recommended.
- When liquid spills onto the fabric, please immediately wipe off liquid spills with a dry or lightly dampened clean white cloth, sponge, or paper towel.

2. Faux Leather Care

- Wipe leather down regularly with a clean, dry microfiber cloth.
- For more stubborn dust, dampen the cloth with distilled water. Make sure that the cloth is not soaking wet. Never let water soak into leather.
- Always be sure to use a soft cloth and never use an abrasive brush or scrubber as this can scratch and damage the leather.

3. Electronics Care

- Inspect all wiring harnesses to make sure they are not damaged or stuck under chair.
- Keep all the electronics free from moisture and temperature extremes.
- Check electrical components frequently for signs of corrosion and replace as necessary.
- Contact Customer Support if damage is present, do not fix it by yourself.

4. Disposal & Recycling

Your power recliner sofa must be disposed of according to applicable local and national statutory disposal regulations. Contact your local waste disposal agency for information on proper disposal of recliner sofa packaging, metal/wood frame components, fabric, electronic components.

V. TROUBLESHOOTING

The following troubleshooting FAQs should summarize what you need to know about your power recliner sofa. If at any time you do not feel comfortable performing the troubleshooting steps listed in this manual, please contact Customer Support for service.

Questions	Answers
What if my lift chair does not operate at all?	<ul style="list-style-type: none">• Make sure all the connections at the bottom of the chair are secured; refer to the Assembly Instructions.• Make sure the GREEN light of the lift remote is on.• Check if the GREEN light on the power adapter is on.• Check all the electrical cords are not crimped or pinched.
What if the massage and heat do not work?	<ul style="list-style-type: none">• Make sure the light of the massage remote is on.• Check whether the USB light is on to determine whether there is a problem with the connecting box.• Check all the electrical cords are not crimped or pinched.• Check if the GREEN light of the power adapter is on.
What if the USB charge ports do not work?	<ul style="list-style-type: none">• Check if the GREEN light at the power adapter is on.• Make sure the USB cable coming out of the right armrest is properly connected to the connecting box behind the bottom of the chair; refer to the Step 3 lift connection in the "Assembly Instructions".

Questions	Answers
What if my lift chair is wobbly?	<ul style="list-style-type: none"> • Check the base of chair to make sure all the rubber seat retainers are not broken. • Make sure the armrests are installed tightly; refer to the Assembly Instructions.
What if the armrest falls apart from seat?	<ul style="list-style-type: none"> • Ensure the two connections on each armrest are all inserted onto the base tightly. • Check the brackets of armrest and base to ensure there is no defects.
What if my lift chair makes a clicking noise?	<ul style="list-style-type: none"> • Check the lift motor and make sure the end of lift motor at the center of pivot point. • Make sure the weight capacity of 320 lbs has not been exceeded.
What if my lift chair tilted to one side?	<ul style="list-style-type: none"> • Check the brackets of backrest are installed into seat tightly. • Make sure the rack of lift chair is in a good condition without any distortion. • Use lift chair on the flat carpet, not smooth floor.
What if the remote is very hot?	<ul style="list-style-type: none"> • Check all wiring harnesses to make sure they are not damaged or frayed. • If all cords are in a good condition, please unplug the remote and cool it for a while before using it. • If there is a burning smell, unplug the remote and contact support to replacement.
Can I add a battery backup for my lift chair?	<ul style="list-style-type: none"> • For safety, we do not recommend adding any battery backup for lift chair.

NOTE:

If the lift recliner still does not operate properly, please contact the Customer Support for help and never attempt to make any repairs or adjustments yourself.

lift motor replacement:

NOTE:

1. Take an original bottom picture for reference before disassembling.
2. The disassembled small parts need to be put away to prevent falling into the rack.

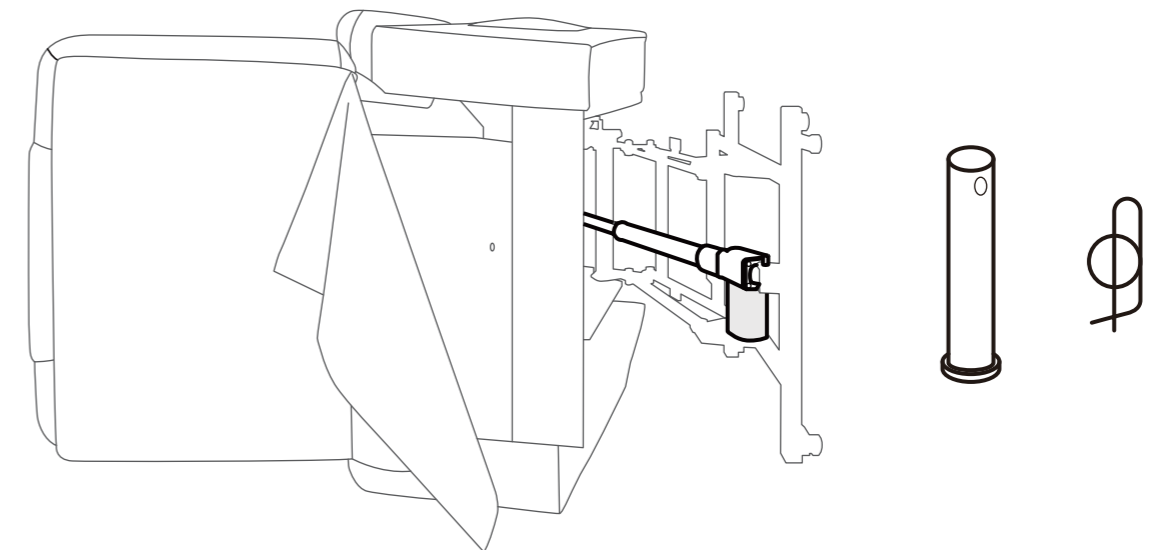

Step1 - Turn the Chair to the Left

First turn the chair to the left, the right armrest is upward, be careful not to break the wire of USB charge ports.

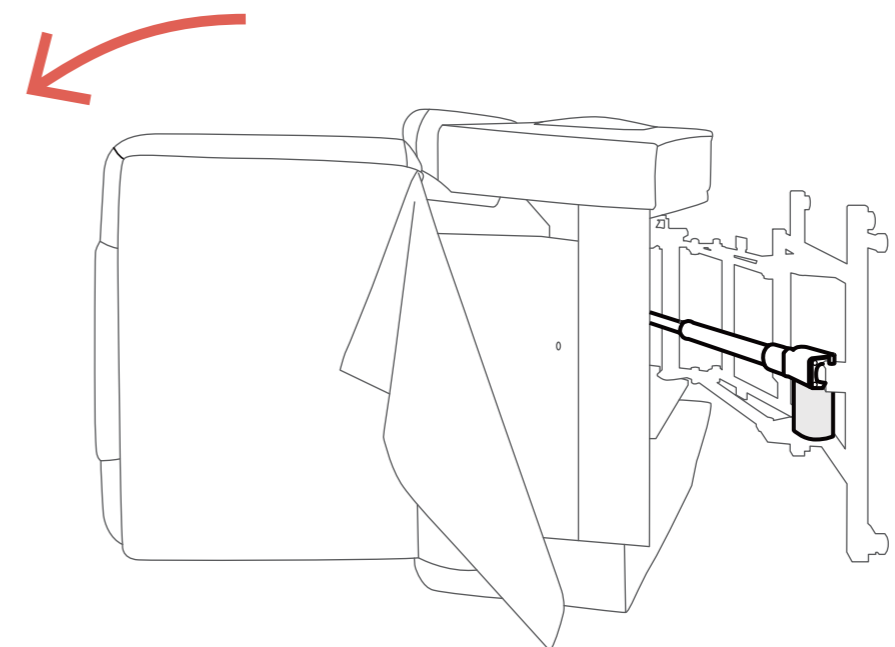

Step2 - Remove Bolts

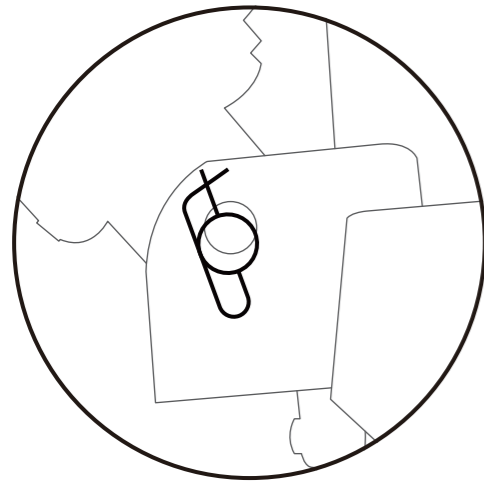

1. The original position of the paper clip

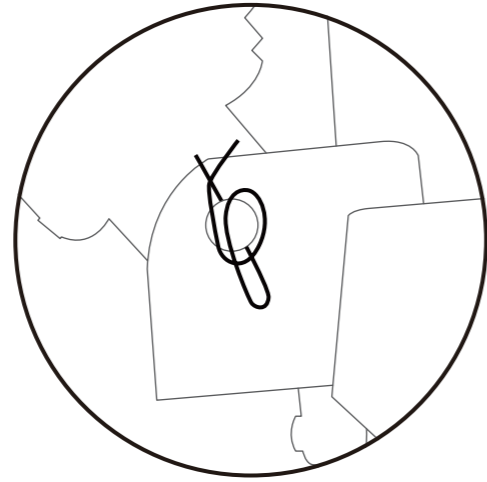

2. Twist the paper clip

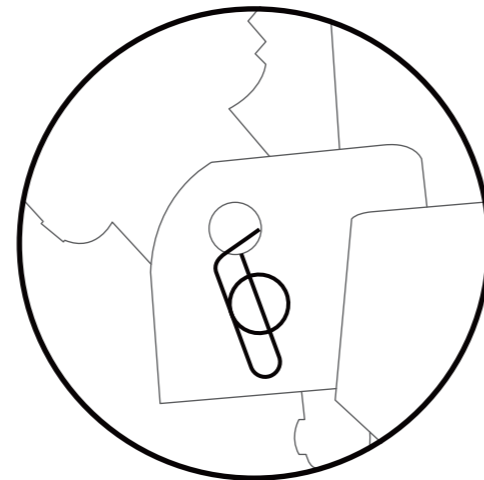

3. Pull out the paper clip

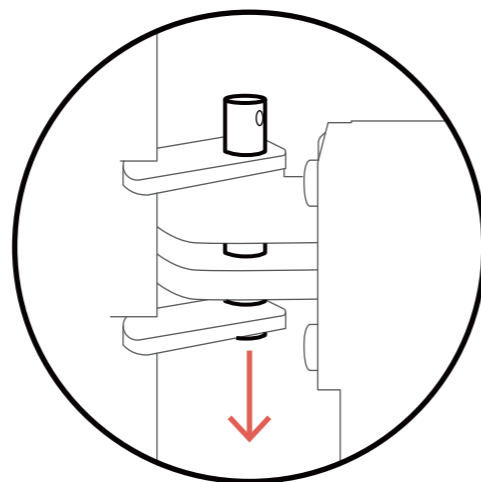

4. Pull out the bolt

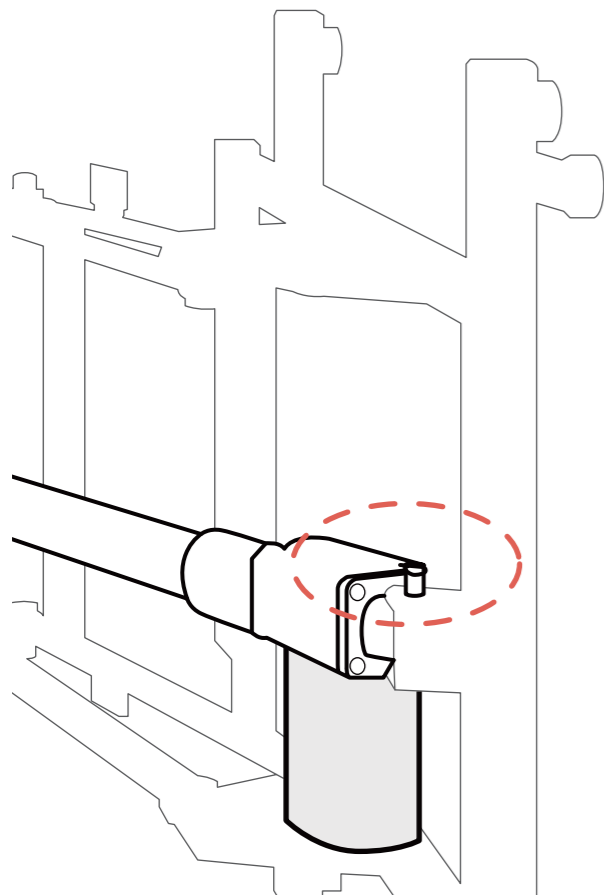

Step3 - Remove Old Lift Motor

Repeat "Step 2" with the other end of the lift motor.

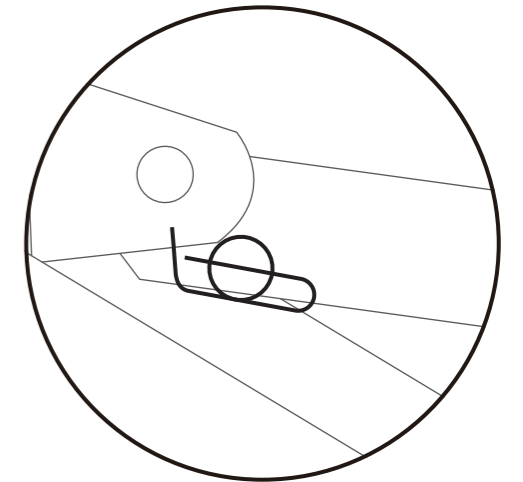
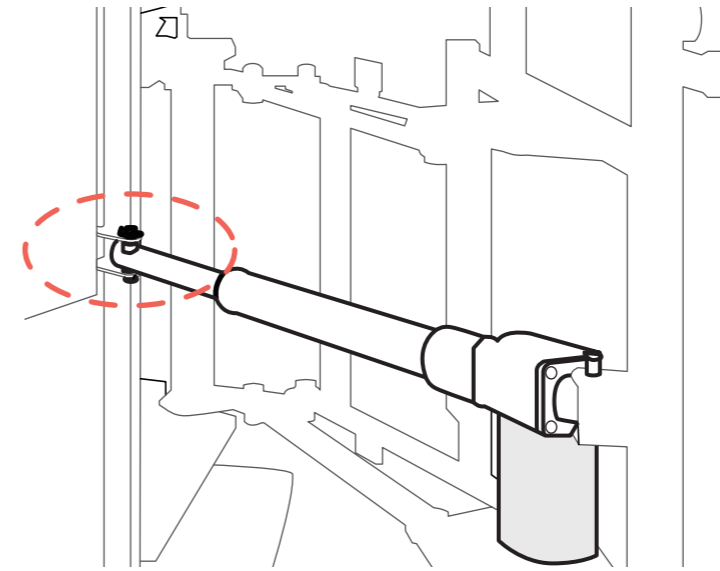

Step4 - Replace the New Lift Motor

Replace the new lift motor.

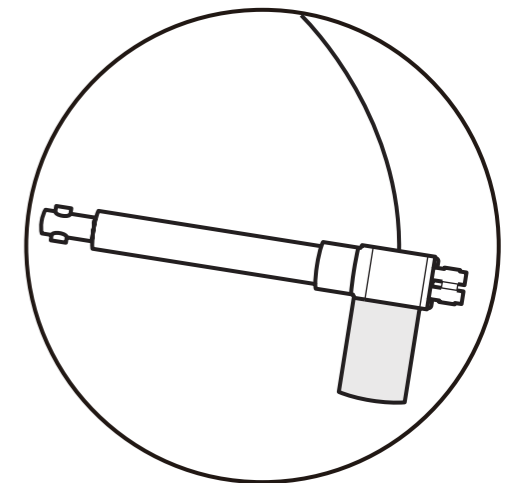
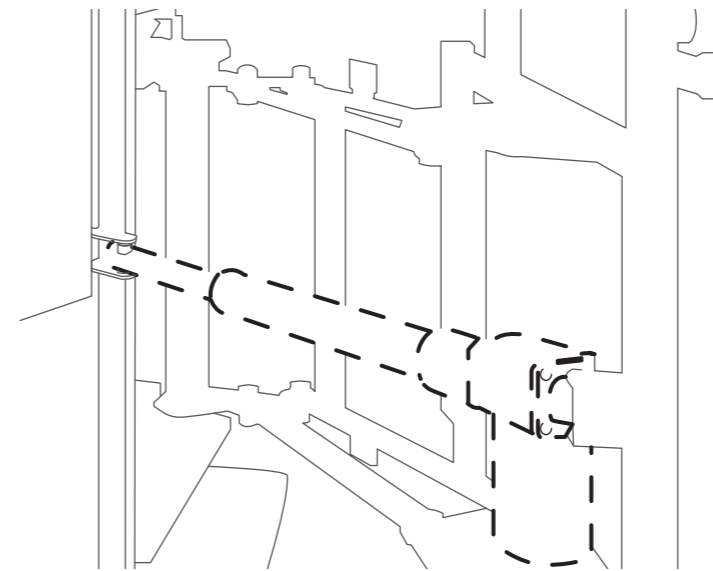

NOTE:

Please note that the motor of the lift motor is facing ground, be careful not to install it backwards, otherwise the lift motor will break.

Step5 - Install Bolts

Insert bolts and paper clips at both ends of the lift motor.

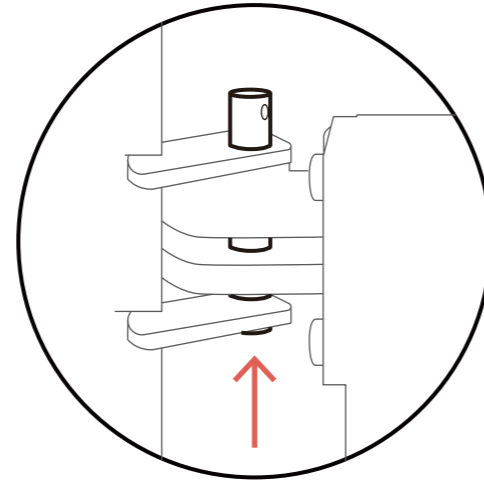
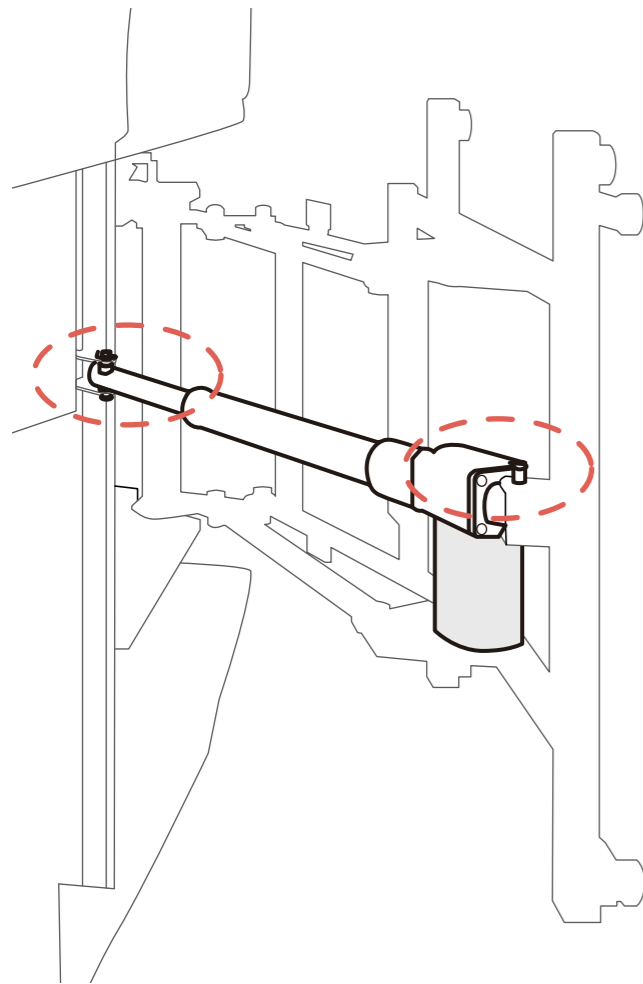

1. Insert the bolt

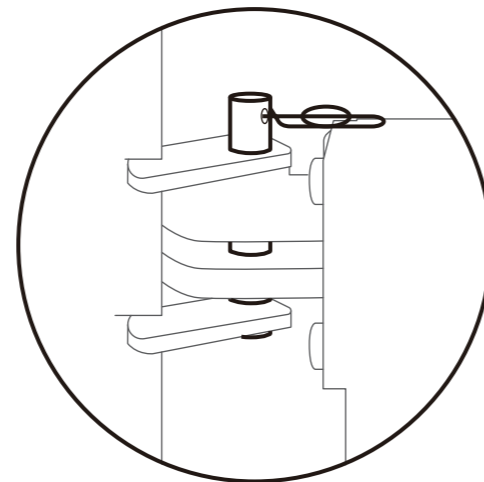

2. Insert the paperclip

Step6 - Final Check

Check & Confirm

1. Make sure bolts and paper clips are fully inserted.
2. Make sure the lift motor is installed in the correct direction.
3. Make sure the wires are not crushed by the seat frame.

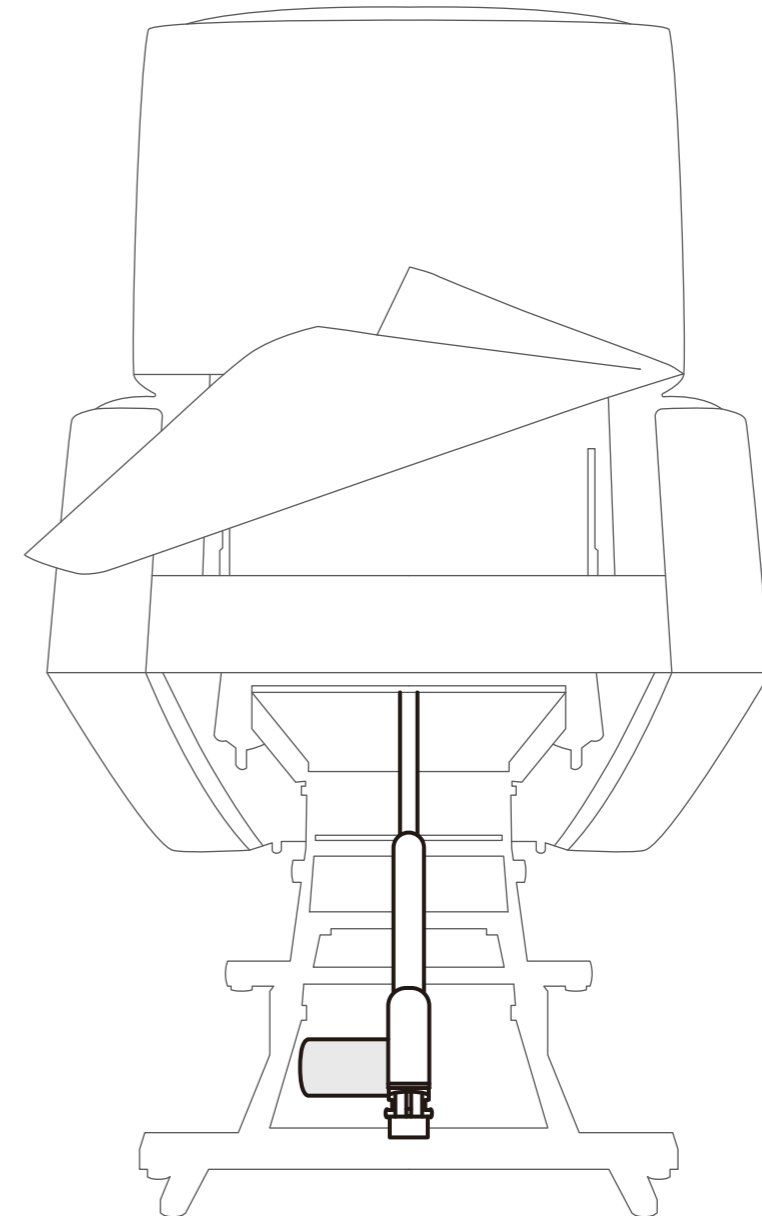

VI. DISASSEMBLY INSTRUCTIONS

■ Notice

- Ensure the chair is in seated position and its footrest return to original position.
- Please unplug the power cord before disassembling.
- Please refer to the installation steps from back to front and disassemble the chair in reverse order.

Step1 - Disconnect all Connections

Please disconnect all connections on the chair base and backrest before disassembling.

Step2 - Disassemble Backrest

1. Pushing the metal ears of the backrest inserts outward (Refer to arrow direction).
2. After unlocking the metal lugs on both sides of the backrest, hold the bottom part of the backrest marked in the picture below and pull it vertically upward.

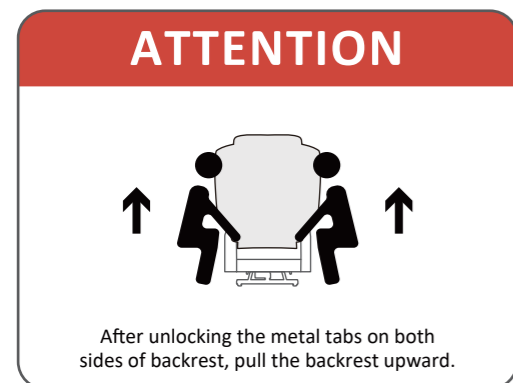
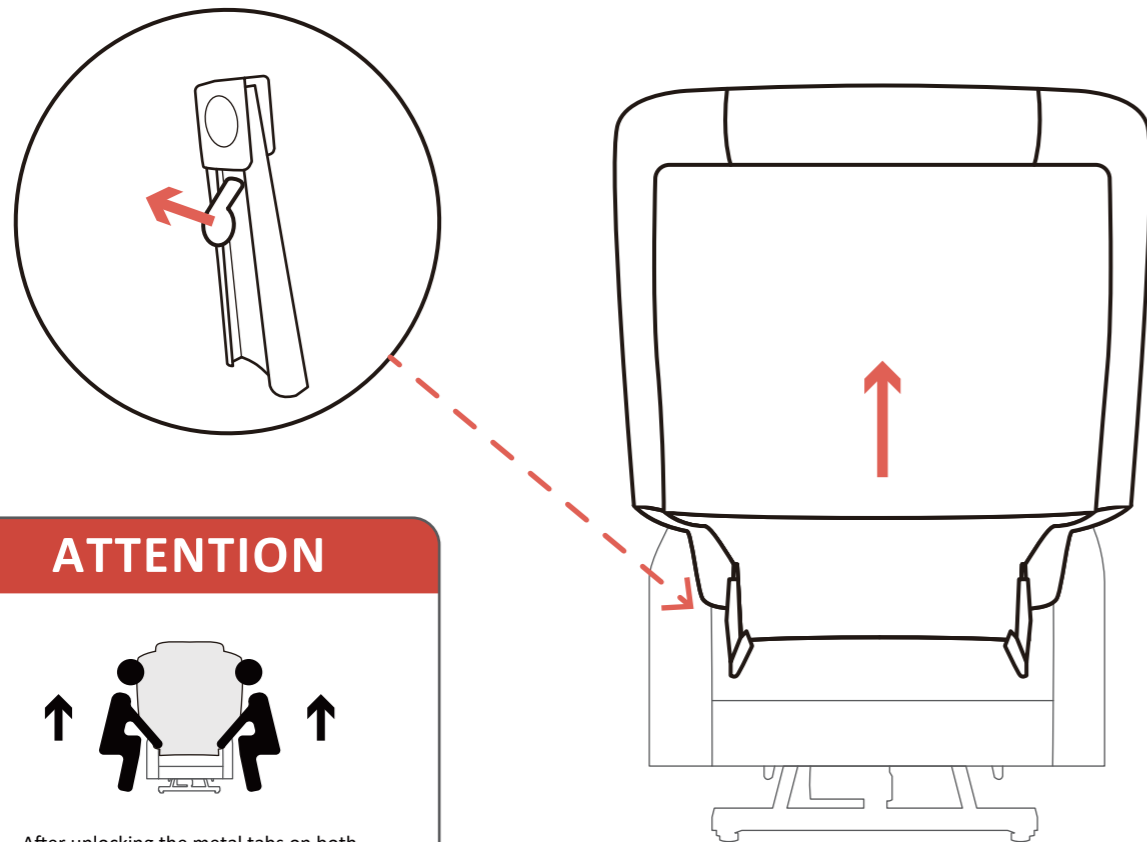

Step3 - Disassemble Armrests

NOTE:

- Need to remove the backrest first.
- It is best to remove armrest by two people.
- When lifting the armrest, be sure to hold the bottom of the armrest to avoid damaging the handrail bag and cup holder.

1. Use your knees to find a support point on the seat and press on the base with your own strength.
2. Hold the two marked positions at the bottom of the armrest and lift the armrest vertically upward. (Refer to arrow direction and the circular marking area.)

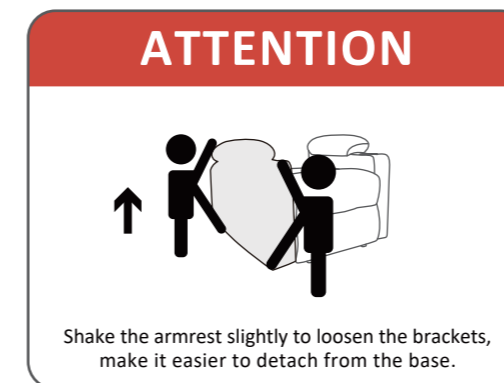
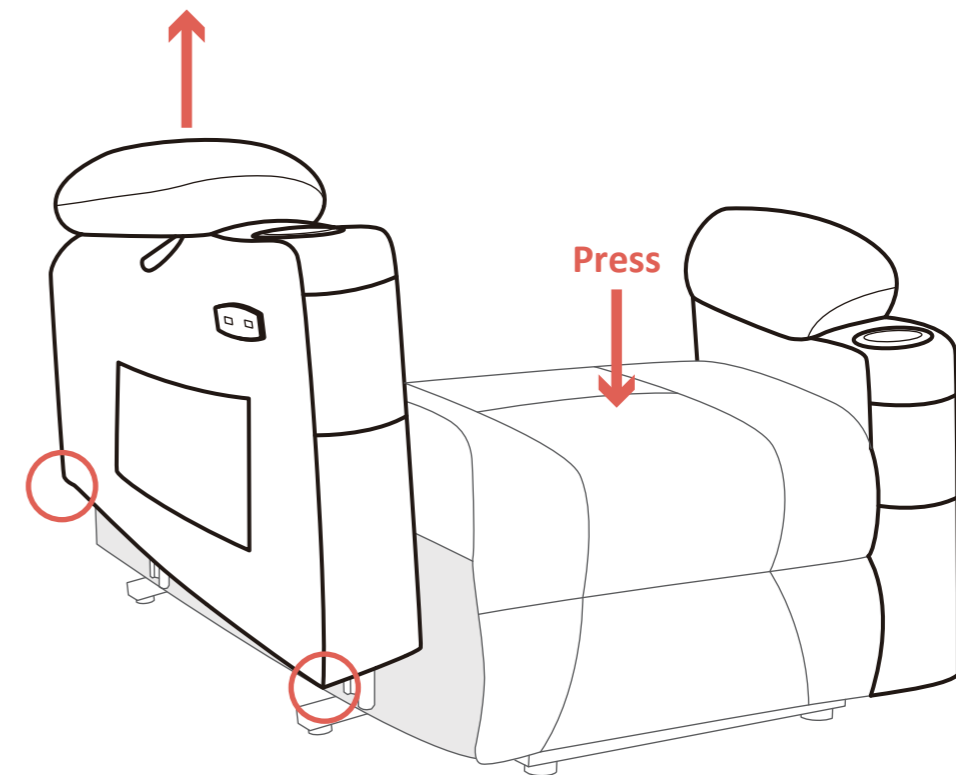

VII. WARRANTY

■ Notice

- For product beyond the limited manufacturer warranty period and scope, we can also provide replacement service, but a basic charge will be charged according to the circumstances.
- The warranty only applies to products and does not include any accessories or enhancements.
- Warranties are only valid in the 48 contiguous United States and are contingent upon the consumer operating the product according to the corresponding instruction manual.

Reclining Mechanism	★ 1 Year
Upholstery Material	★ 1 Year
Metal/ Wood Chair Frame	★ 1 Year
Electronic Parts	★ 1 Year

CONSUMER WARRANTY LIMITATIONS AND EXCLUSIONS

All warranties begin on the date of delivery.
All warranties are to the original purchaser ONLY.

- We will replace the defective parts or send replacement product provided that the warranty parts have not been subjected to misuse, abuse or improper service by the consumer, for example, damaged wire arising in consequence of negligence or improper operation.
- Exclusions also include components with damage caused by:
 - Contamination
 - Abuse, misuse, accident, or negligence
 - Commercial use, or use other than normal
 - Improper operation, maintenance, or storage

NOTE:

We will pay standard shipping rates on all warranted parts for the first year. We can also sell you replacement part for a discount price when your product is out of warranty policy.

VIII. RETURN/ REPLACEMENT POLICY

■ Notice

Why don't we recommend returning the item by yourself?

- Huge cost- UPS/FedEx oversize fee.
- Need you to take the box to UPS/FedEx facility.

Return/ Replacement Policy

You have 30 days from the date of purchase to return any item purchased from our store. Please securely pack the item in its original packaging, including any accessories or manuals that came with the product. To initiate a return, please contact our customer service team for any help.

Return Conditions

We accept the return of items that are in new, unused condition, with original tags attached and all original packaging and other components included. Refunds will be issued in the original form of payment for the price of the item, including taxes.

- Please keep the original packaging in case the product needs to be returned. If the original packaging is not available, the newly found packaging needs to meet the following size standard:
UPS/FedEx packaging size standard: (width+ height) * 2+ length < 128 inch.
- Please disassemble the product before you return it, otherwise there will be a huge cost as oversized and it could even exceed your order amount.
- Please do not purchase return label for a damaged/defective product by yourself.
- If you have any problem to return the product, please contact us immediately, we will do our best to help you with a reasonable solution.