

NOTICE

*Please make sure that you have all parts indicated and they are in good condition before you begin assembly of this item. Refer to part list and hardware list below for guidance.

*This item should be assembled on a soft surface to prevent scratching the finish during assembly.

*This item may require periodic tightening.

*If you are having difficulty, our friendly Customer Care team is always here to help.

PREPARATION

*Before beginning assembly of product, make sure all parts are present. Compare parts with package contents list and hardware contents list.

*If any part is missing or damaged, do not attempt to assemble the product.

*Estimated Assembly Time: 20 minutes.







*Tools required for Assembly (included): Allen Key

CARE AND MAINTENANCE

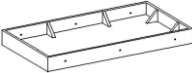
Always use felt pads under all articles to prevent discoloration or softening of the lacquer. Plastic and rubber bases on items can discolor wood. Wipe up spills immediately and avoid common hazards such as hot dishes, harsh solvents and abrasives. Cleaning should be done with a soft lint free cotton cloth dampened with water or furniture polish.

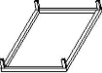
On highly used surfaces we recommend applying a quality paste wax which should be used on a regular basis to provide additional protection from scratches and spills. How often you apply the wax depends on how much wear the furniture receives.

Part List and Hardware List

PIECE	DESCRIPTION	PICTURE	QUANTITY
A	Table top		1x
B	Crossbeam		2x
C	Crossbeam		2x
D	Leg frame		2x
HW1	Hex bolt: 6x0.5x10mm		16x
HW2	Hex bolt: 6x0.5x30mm		6x
HW3	Flat washer: 6mm		22x
HW4	Allen key		1x

Product Dimension: 44.9Wx25.2Dx16.5H"

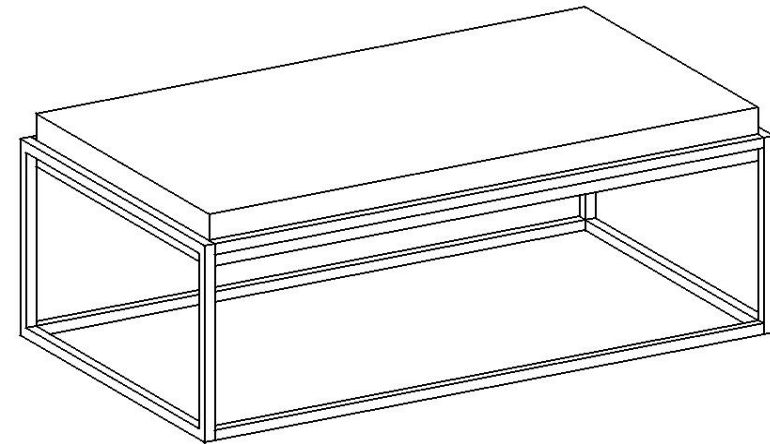

Weight Capacity : 110 LBS
Warning : Do not stand on table
Warning : Do not over torque bolts

PREPARATION

- *Before beginning assembly of product, make sure all parts are present. Compare parts with package contents list and hardware contents list.
- *If any part is missing or damaged, do not attempt to assemble the product.
- *Estimated Assembly Time: 20 minutes.
- *Tools required for Assembly (included): Allen Key
- *If you are having difficulty, our friendly Customer Care team is always here to help.

Hardware is located inside the box. You can find them placed near the sign 'HARDWARE INSIDE'

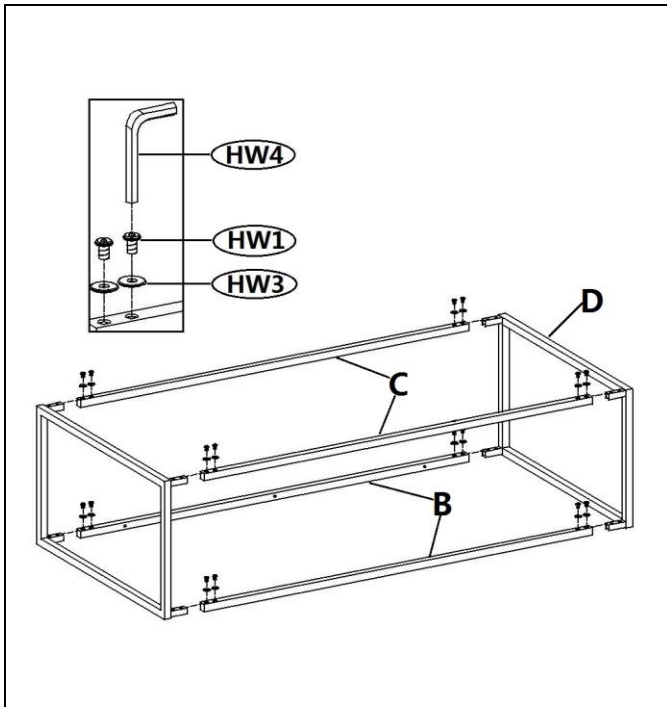

Step 1: Put the Flat washer(HW3) on the Hex bolt(HW1), insert the Crossbeam(B and C) into Leg frame(D) in order. Insert the Hex bolts into the mounting position and tighten them by using Allen key(HW4).

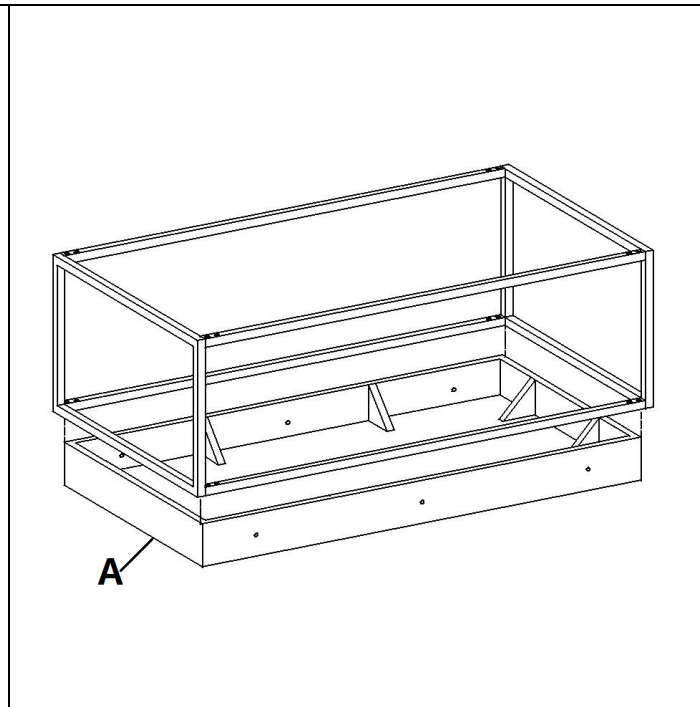

Step 2: Put the Leg frame on Table Top(A), make the mounting positions aligned.

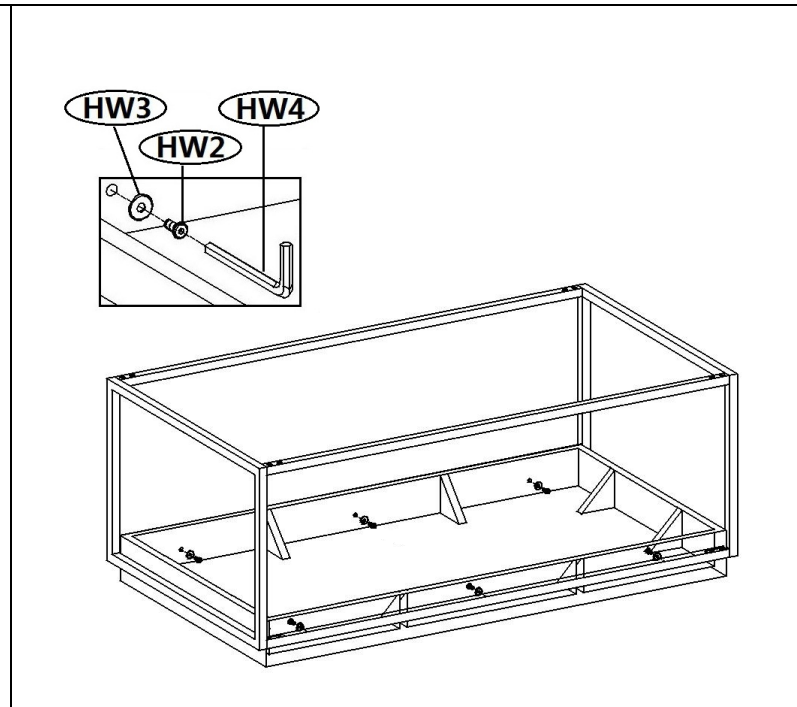

Step 3: Put the Flat washer(HW3) on Hex bolt(HW2), insert them into the mounting positions on the Table top(A), tighten then by using Allen key(HW4).