

Metal Storage Shed Owner Manual & Assemble Guide_SS16245

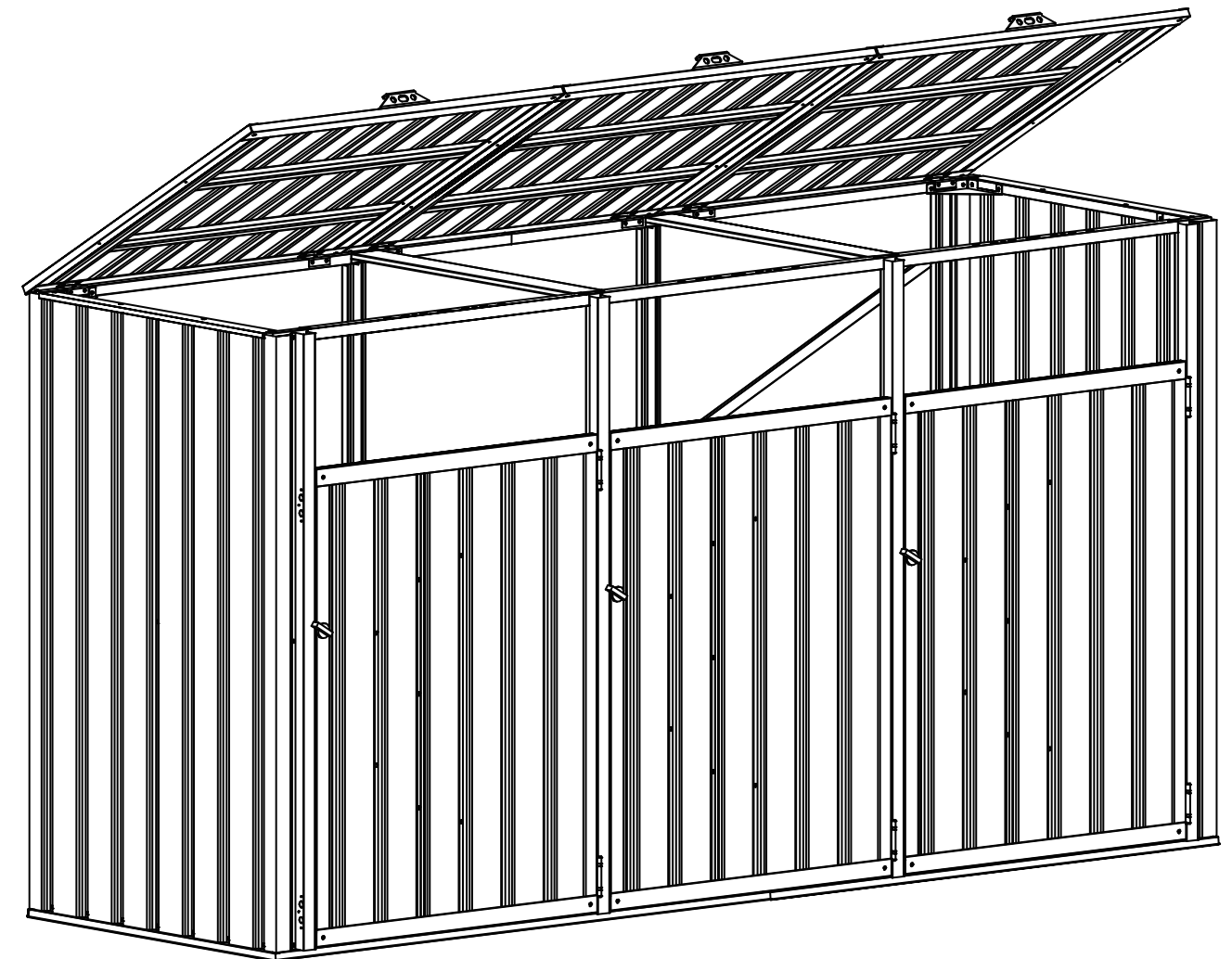

Customer Service:

If you have any problem, please contact us through the online platform.

All parts are packed in one box, please note that refer to the parts list to check if all parts are received.

Please prepare below tools before installation. (Not Included)

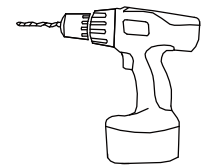

Electric Screwdriver

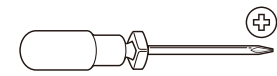

+ Manual Screwdriver



Ladder

Package included Tools



Gloves x 1Pair

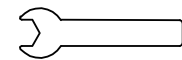

Spanner x 1

ATTENTION

Care **MUST** be taken when handling various pieces of your building since many contain sharp edges.

Do NOT attempt to assemble your building before double checking that you have all parts indicated in the parts lists. Any building left partially assembled may be seriously damaged by even light winds.

Do NOT attempt to assemble your building on a windy day, the large panels can catch the wind like a "sail", making construction difficult and unsafe. **Watch the weather closely.**

Keep children and pets away from the worksite during construction and until the building is completely assembled. This will help avoid distractions and any accidents which may occur. Never concentrate your weight on the roof of the building.

Before assembling any parts, your base should be constructed and an anchoring system should be ready to use. Your building must be anchored to prevent wind damage.

ASSEMBLY

The best location is a level area with good drainage.

Allow enough space outside the building to be able to access the roof with a ladder.

USE TEAMWORK: Two or more people are required to assemble your building.

CARE & MAINTENANCE

Do NOT use power washing to clean your shed.

Combustibles and corrosives must be stored in air tight containers designed for chemical and/or combustible storage.

Rust Protection Precautions

Avoid nicking or scraping the coating surface, inside and out.





PLEASE KEEP THIS INSTRUCTION FOR FUTURE REFERENCE.





Part List

PART	NO.	QTY.
	L38-1L	2
	L38-1R	2
	L38-2	2
	L38-0	2
	L38-3	2
	L38-4L	1
	L38-4M	1
	L38-4R	1
	L38-5L	1
	L38-5M	1
	L38-5R	1
	L38-6	3
	L38-7	2
	L38-9	3
	L38-10	3
	L38-11	6
	L38-12	6
	L38-13	4

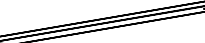
PART	NO.	QTY.
	L38-DX1	6
	DXF4	3
	L38-UA1	1
	L38-UA2	3
	L38-UA3	4
	GB	3
	T-F	8
	DJ	6
	T-G	4
	DH2	6
	GM	3
	F1	349
	V2	42
	F2	24
	SL	60
	M20	1
	ST	2
	L38-8M	3

Part List

PART	NO.	QTY.
	L38-14	2
	L38-15	2
	L38-DLA1	3
	L38-DRA1	3
	DDAJ	6

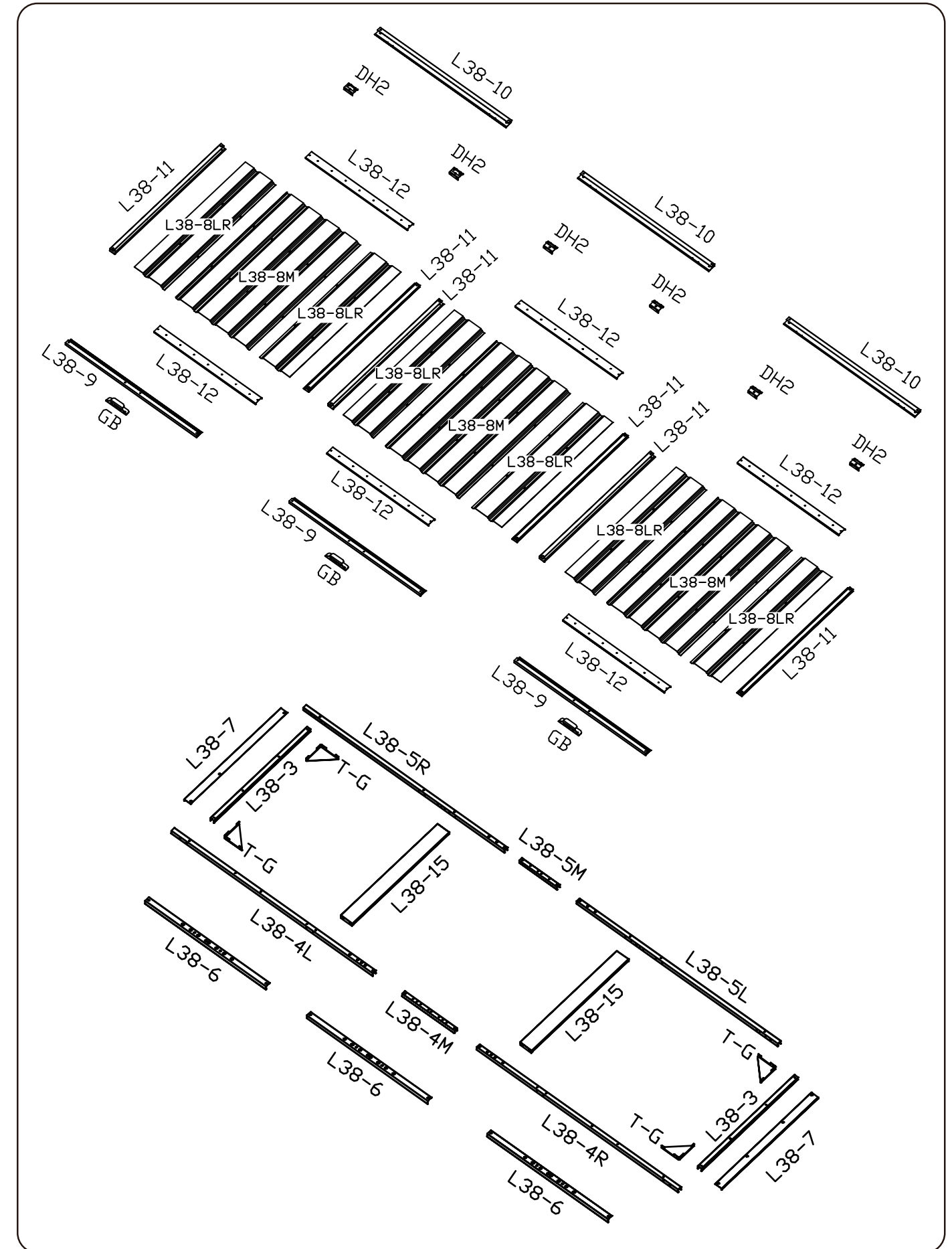

PART	NO.	QTY.
	L38-8LR	6
	W5-CG	4
	L38-W5X	3
	L38-W3HX	3

Part List

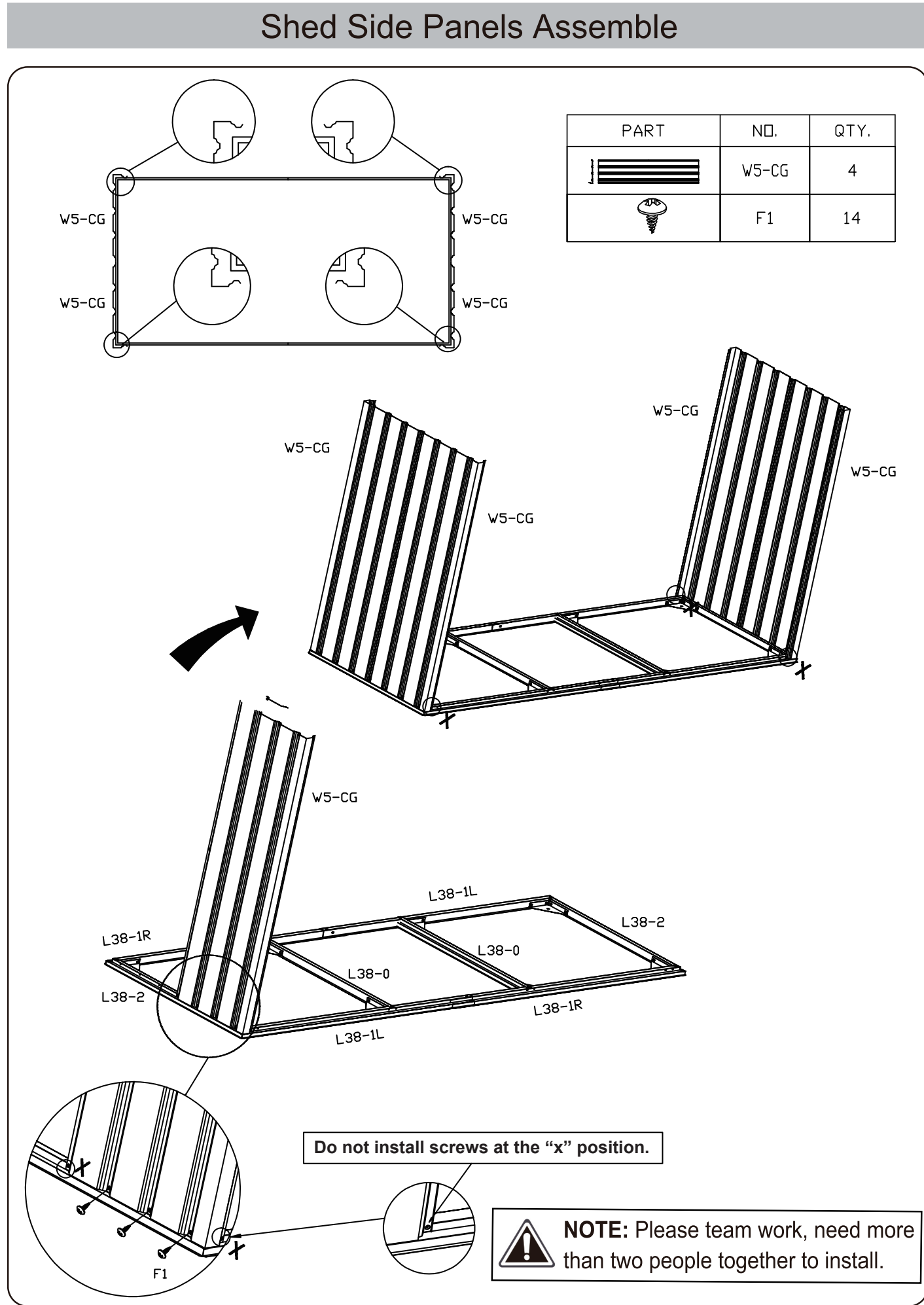
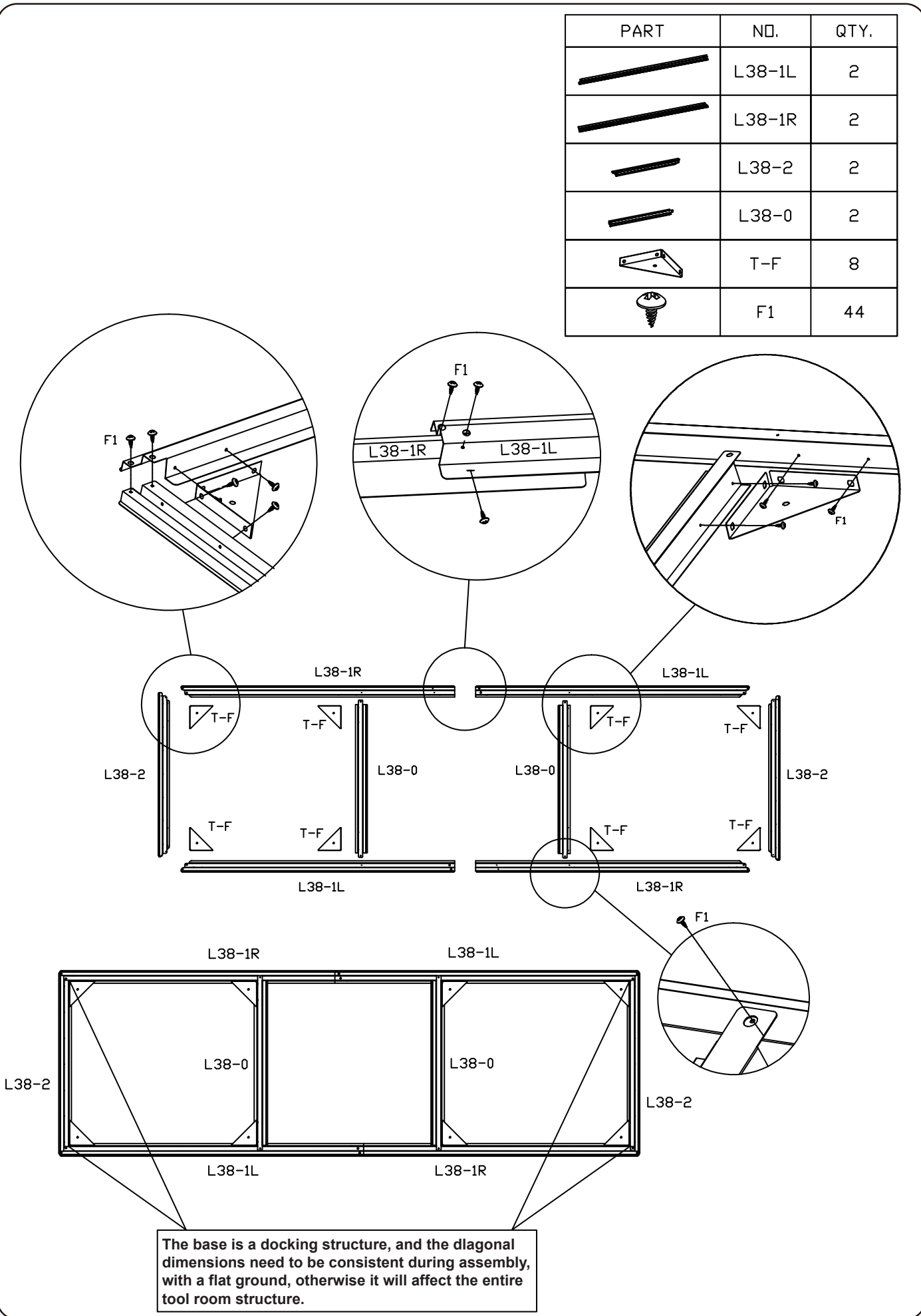



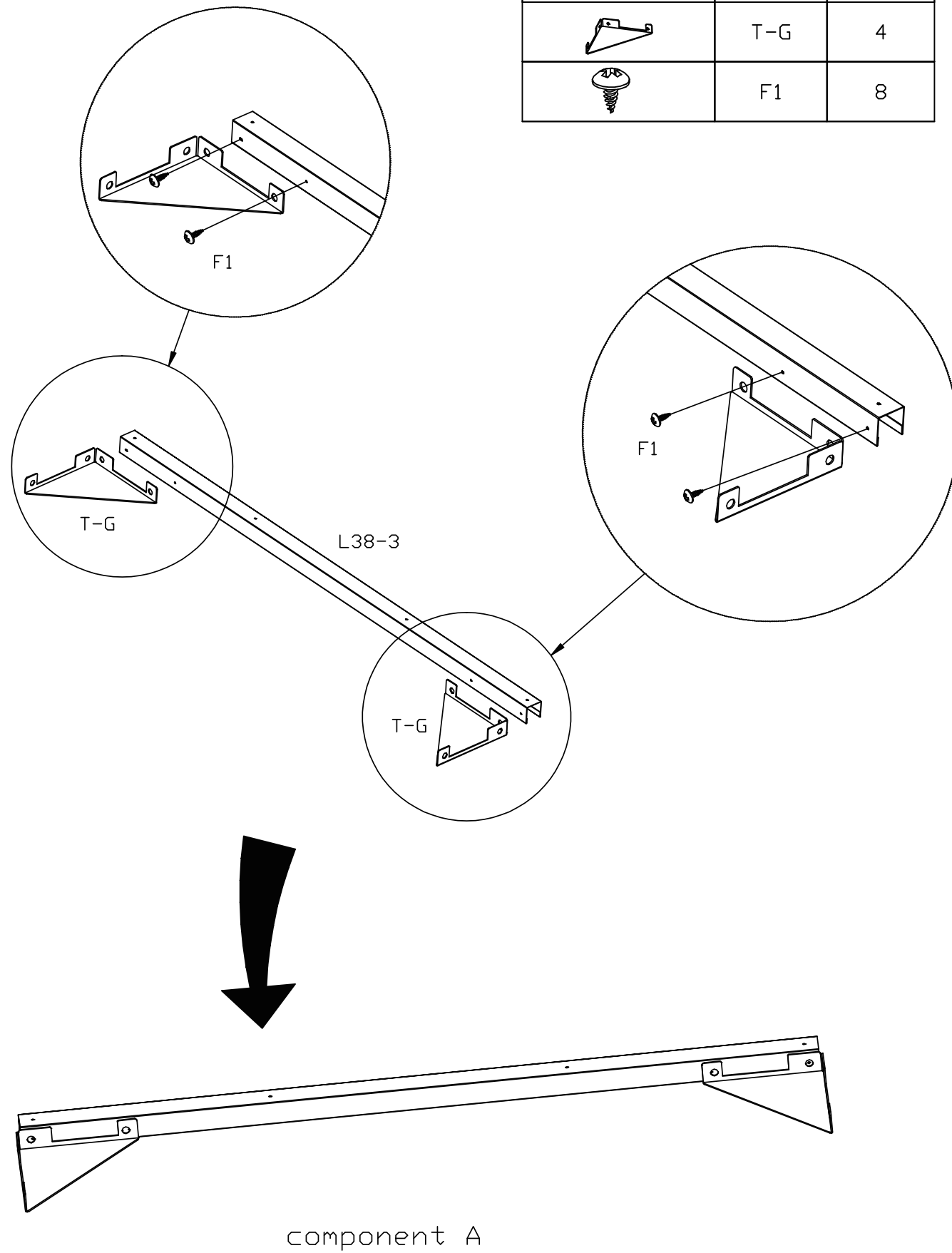

2 Groups

PART	NO.	QTY.
	L38-3	2
	T-G	4
	F1	8





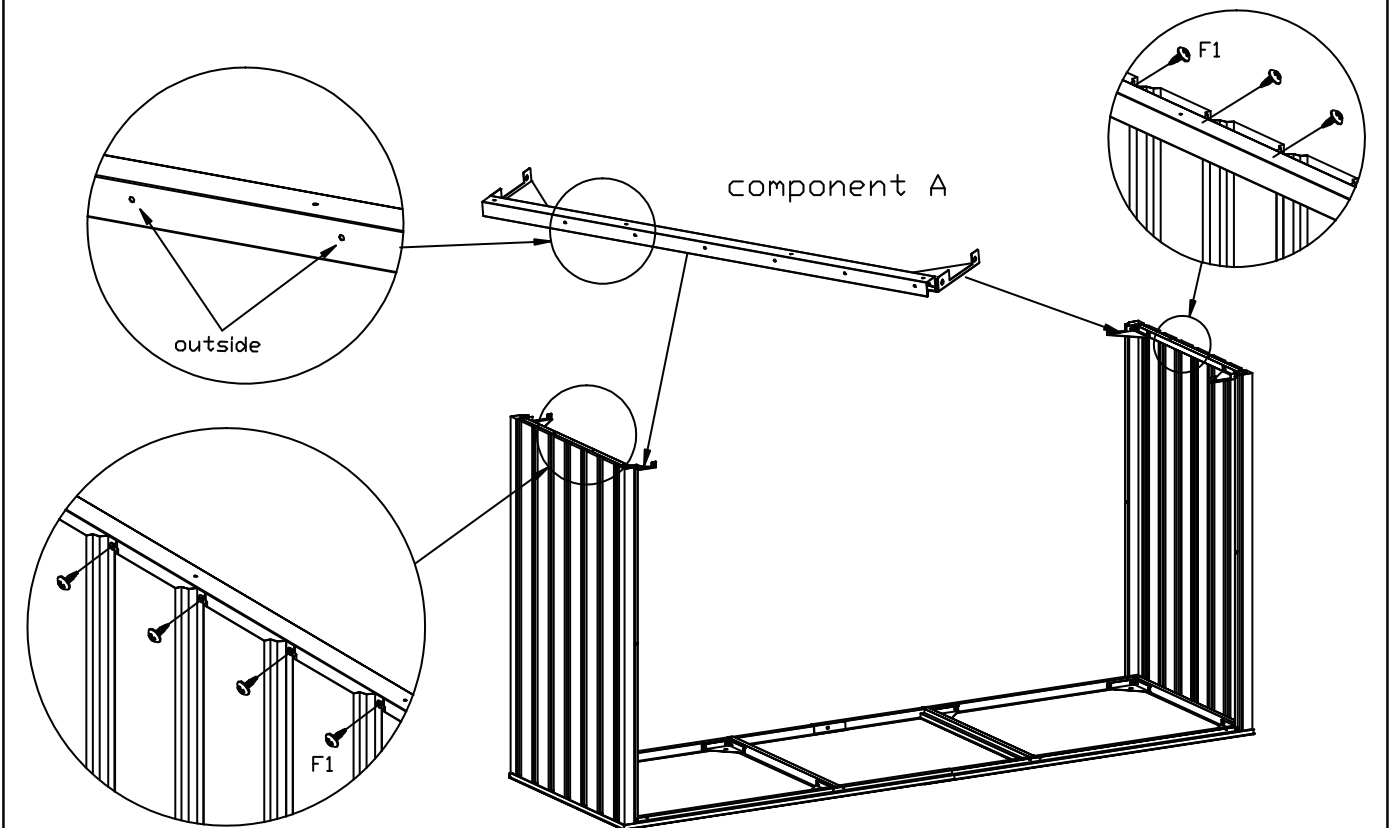

10

PART	NO.	QTY.
	component A	2
	F1	14



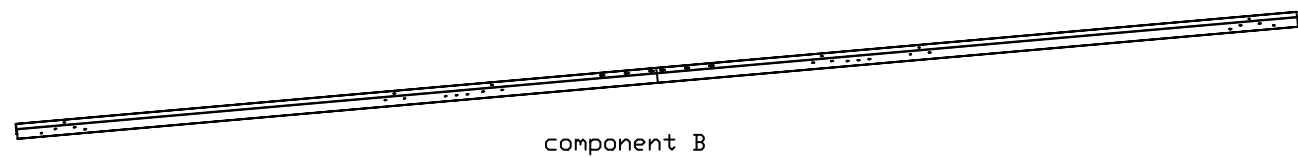
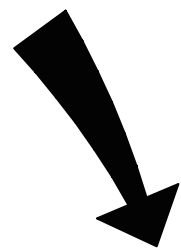
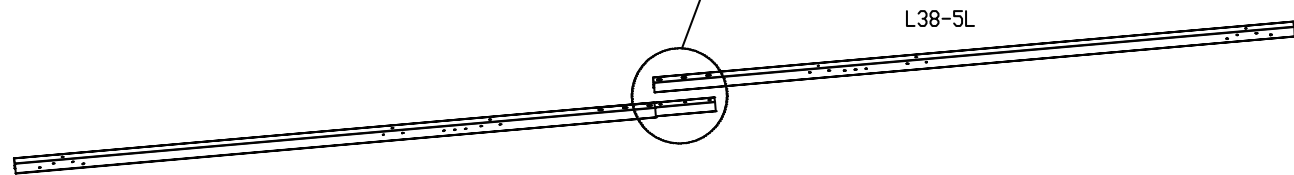
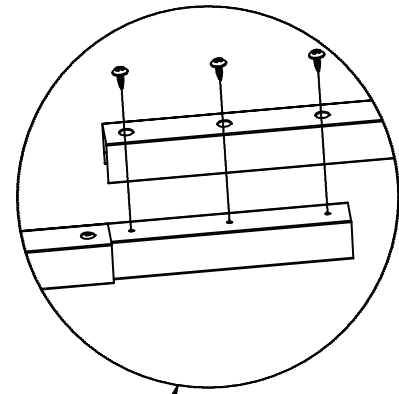
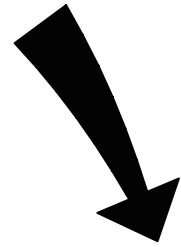
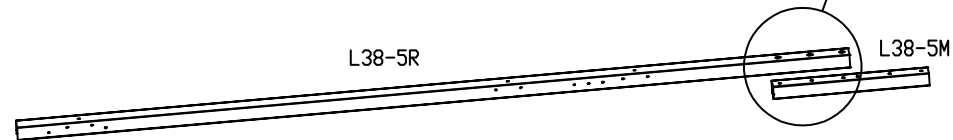
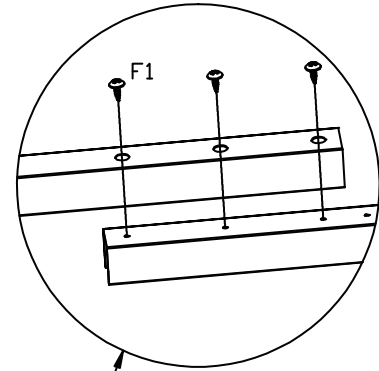

11

PART	NO.	QTY.
	L38-5L	1
	L38-5M	1
	L38-5R	1
	F1	6



12



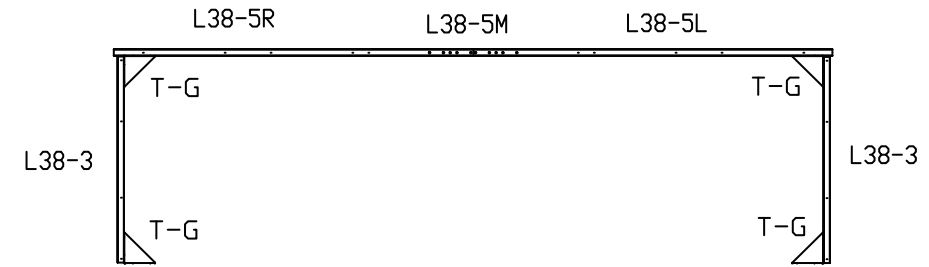

PART	NO.	QTY.
	component B	1
	F1	4

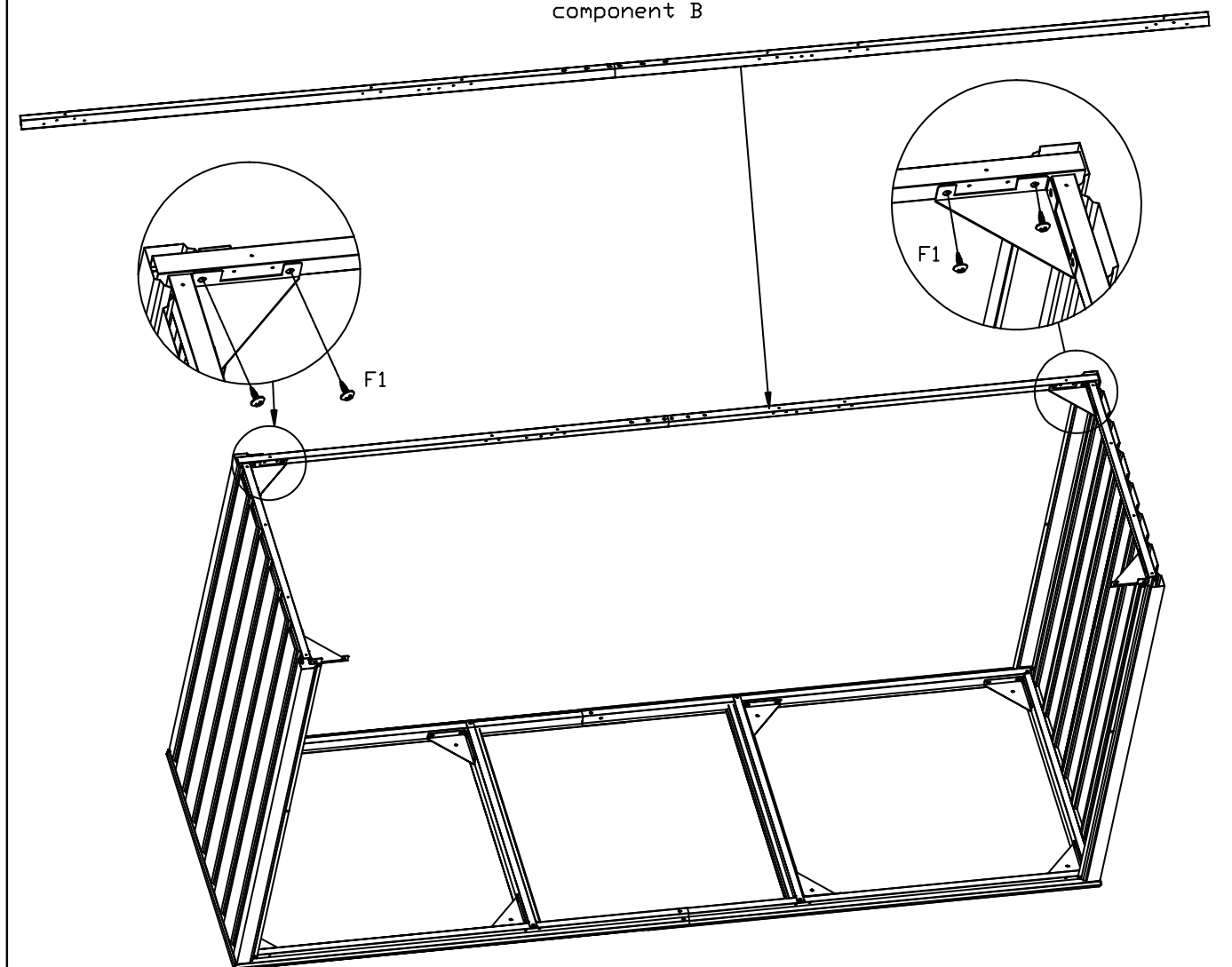



component B

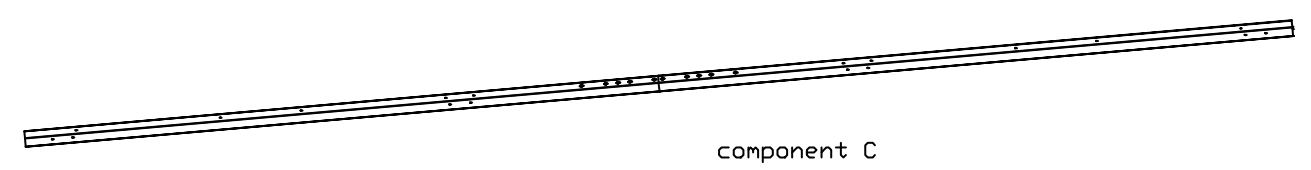
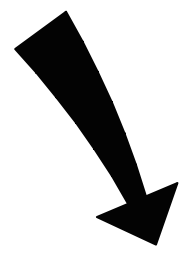
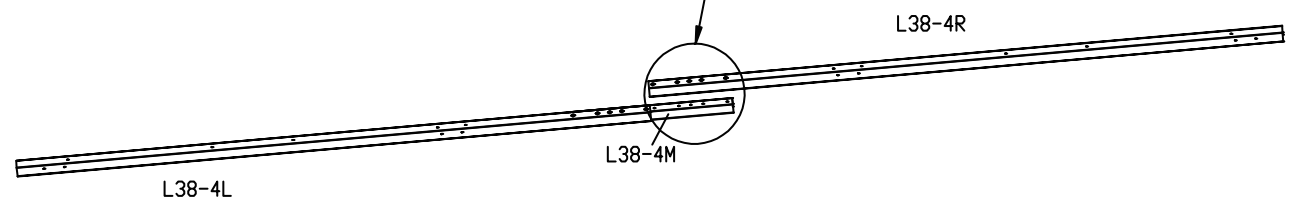
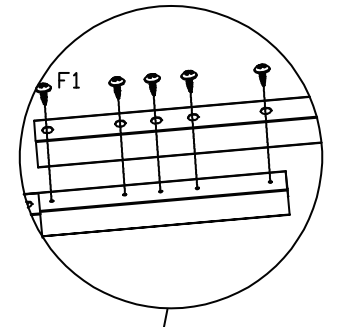
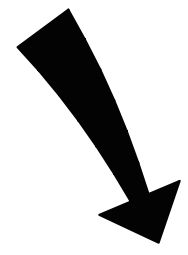
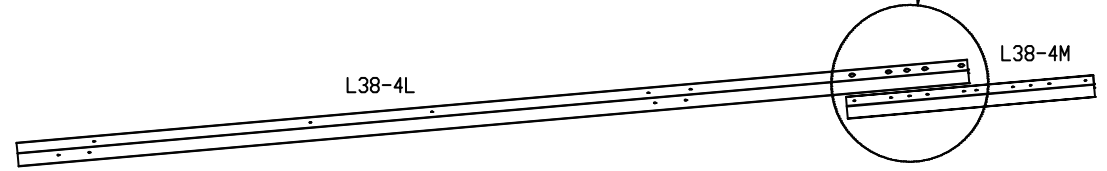
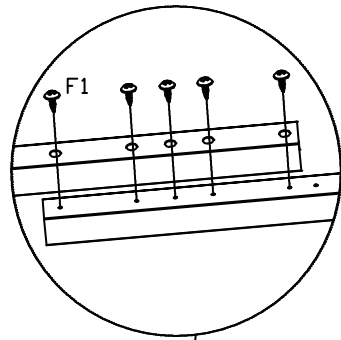

13

PART	NO.	QTY.
	L38-4L	1
	L38-4M	1
	L38-4R	1
	F1	10



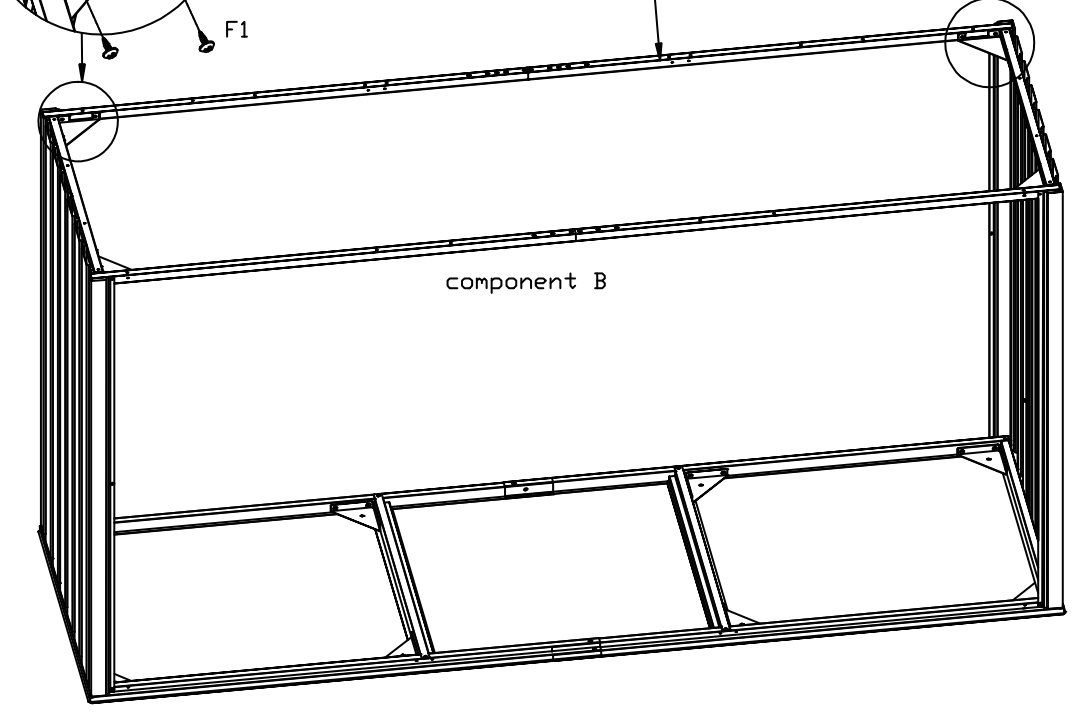
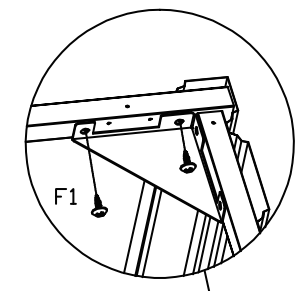
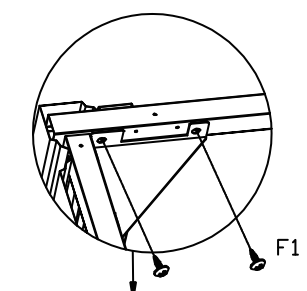
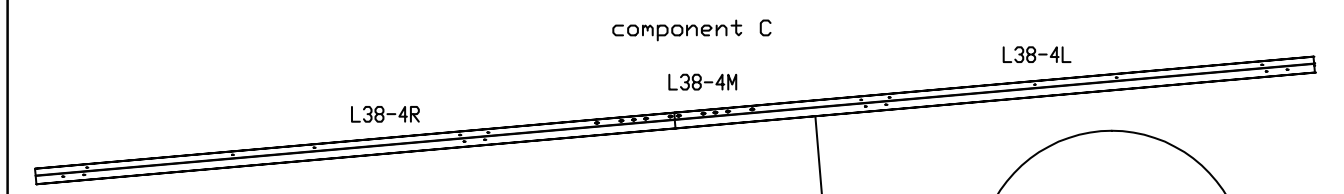
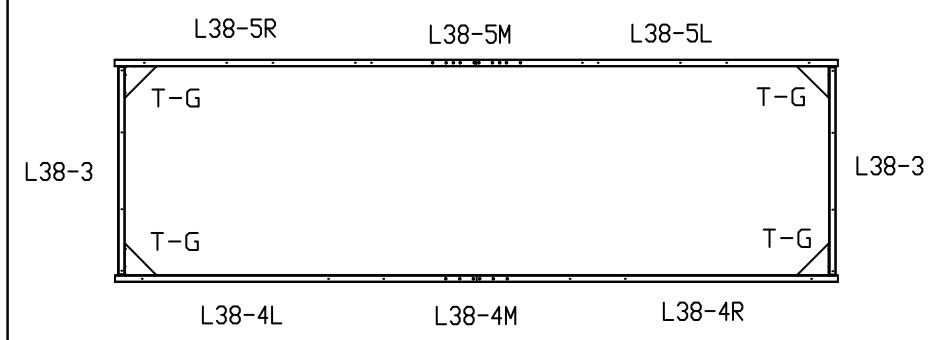

PART	NO.	QTY.
	component C	1
	F1	4

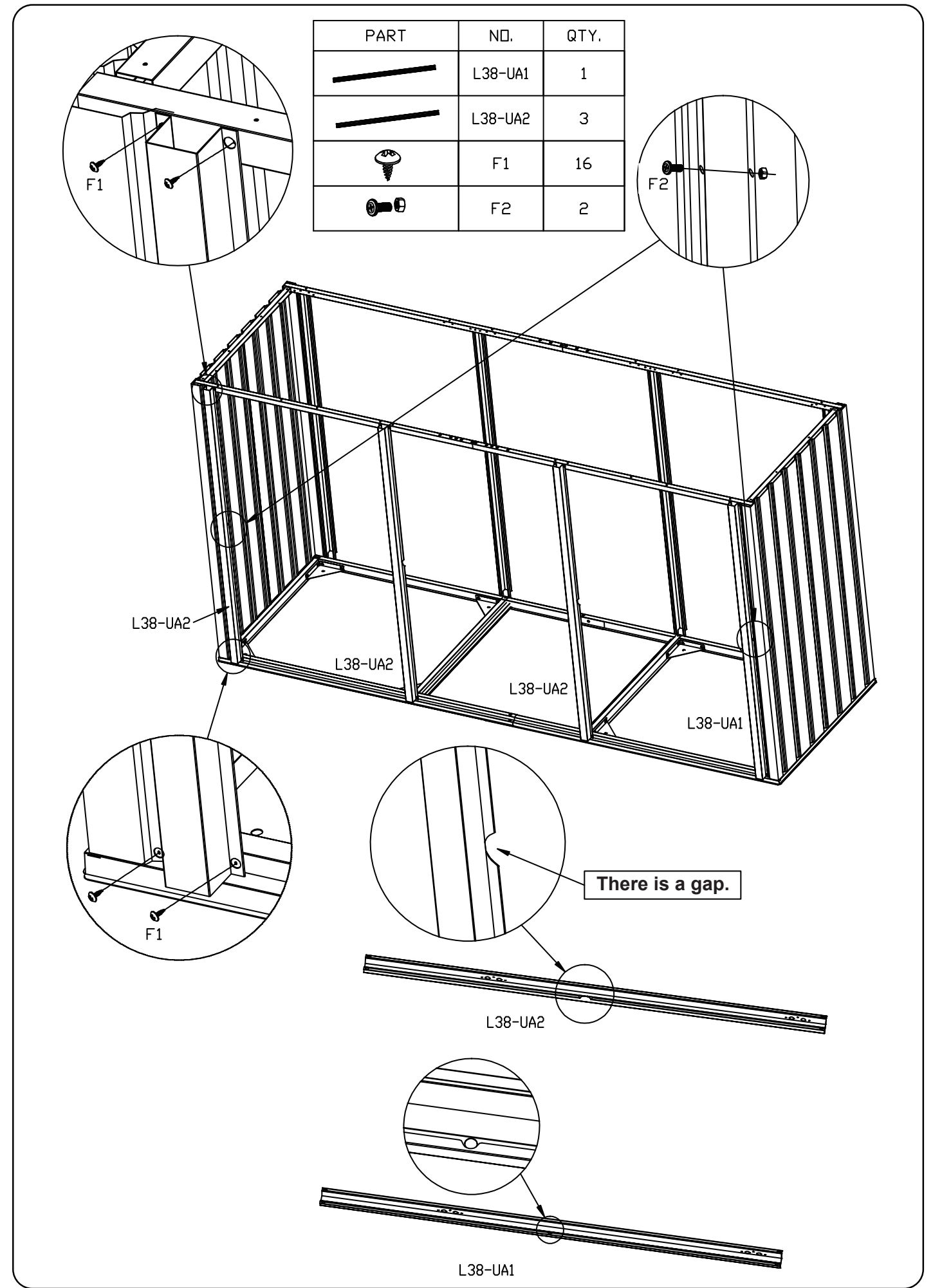
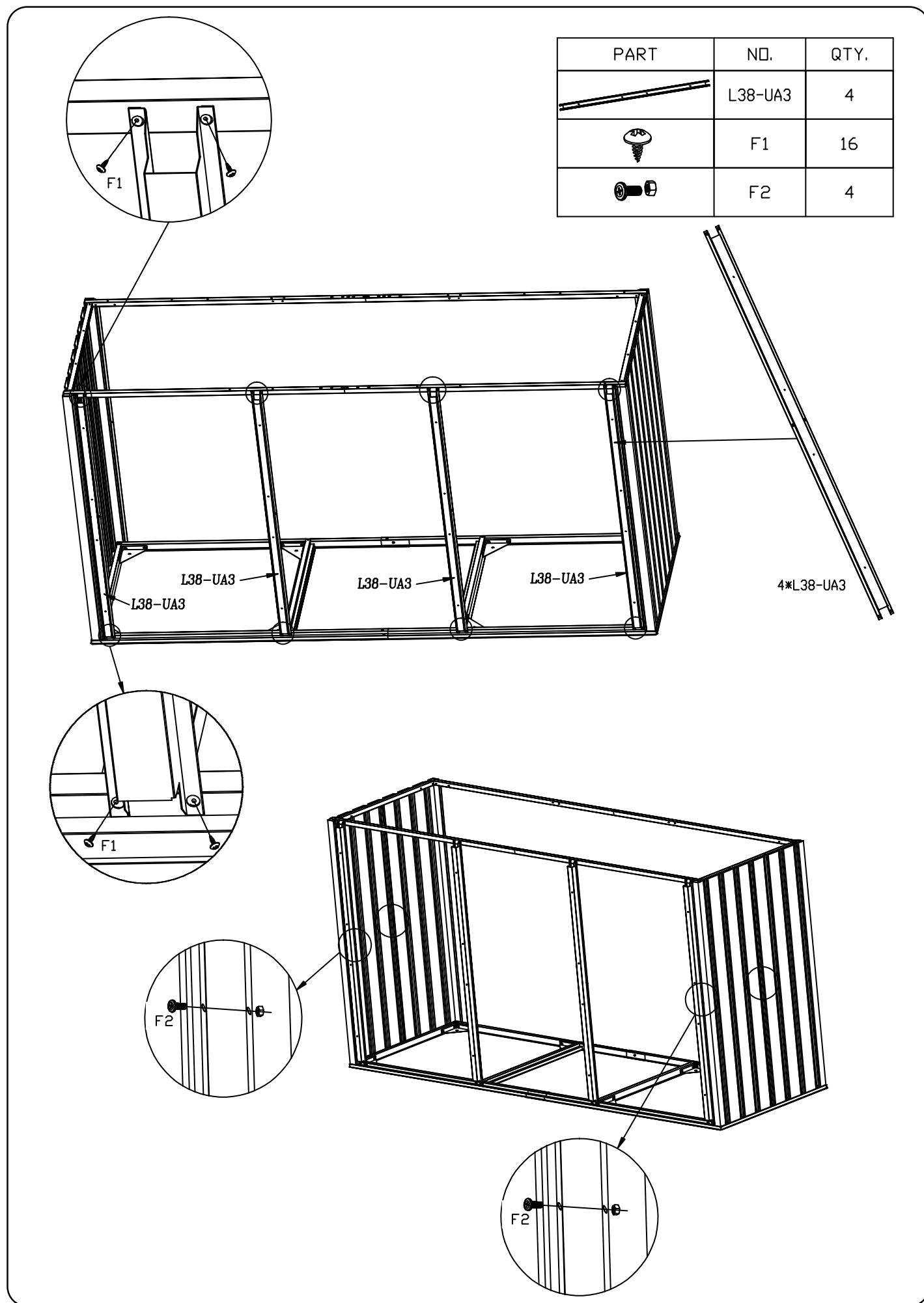





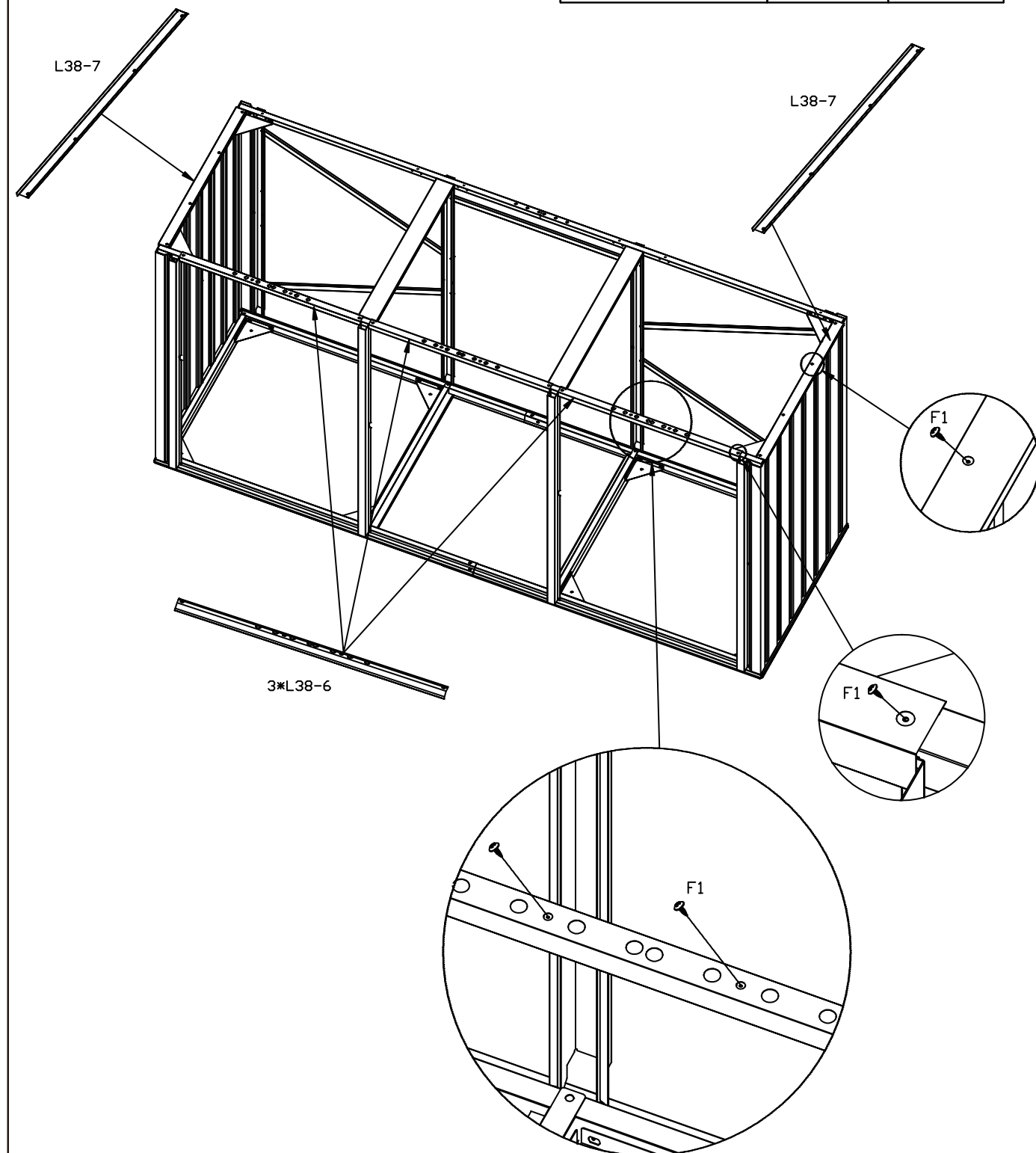

Shed Top Assemble

PART	NO.	QTY.
	L38-7	2
	L38-6	3
	F1	16

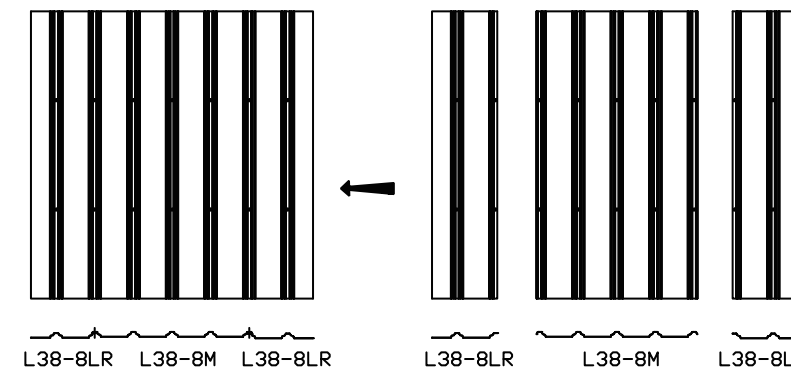

20

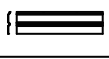
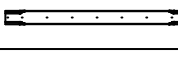

PART	NO.	QTY.
	L38-8M	3
	L38-8LR	6
	L38-12	6
	F1	42
	V2	42

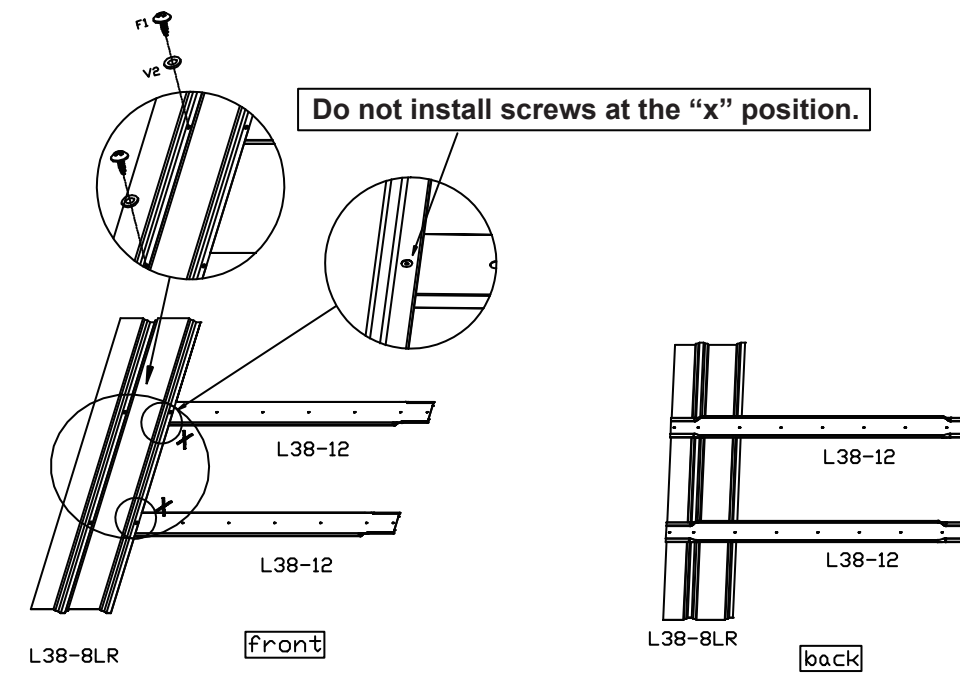

3 Groups

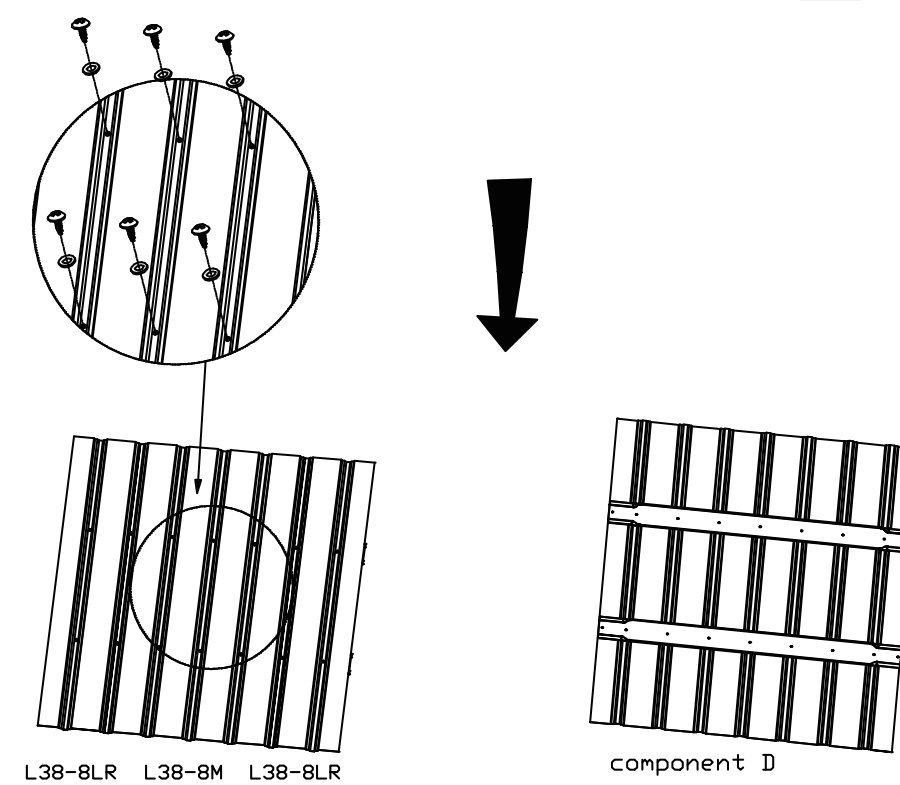

21

3 Groups

PART	NO.	QTY.
	L38-9	3
	L38-10	3
	L38-11	6
	component D	3
	F1	36

Attention: Assemble the connecting rod according to the hole positions shown in the diagram.

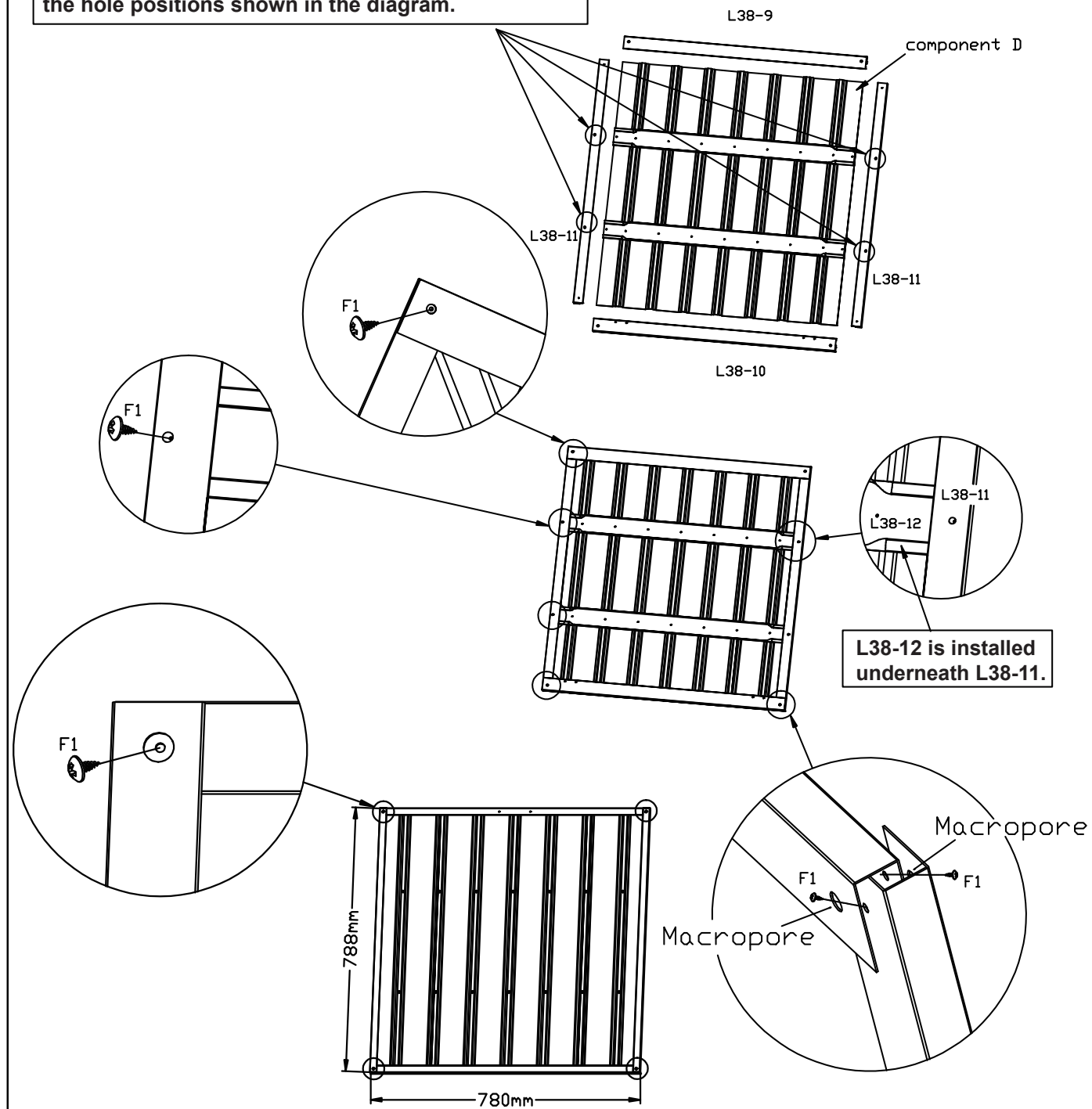

3 Groups

PART	NO.	QTY.
	GB	3
	DH2	6
	F1	18

Front

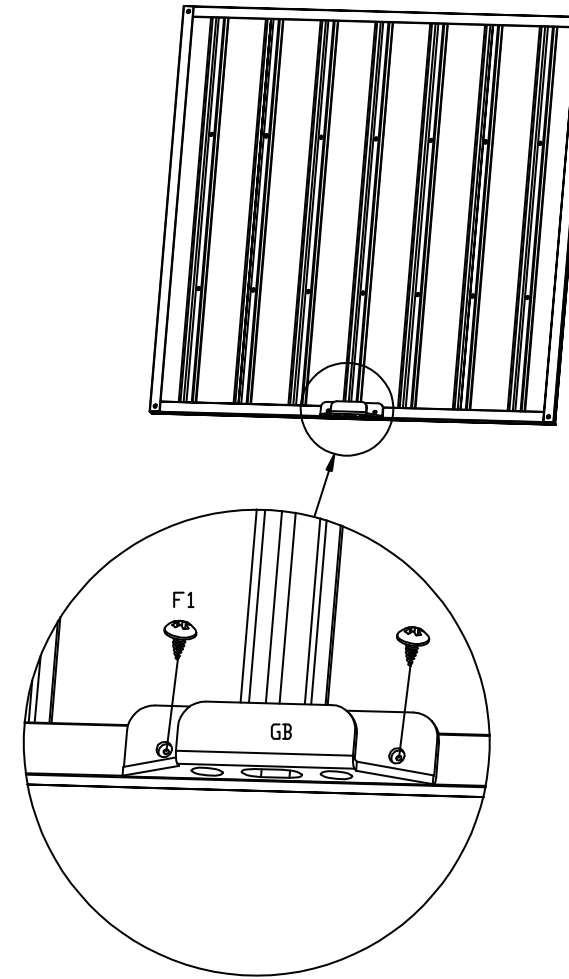

Back

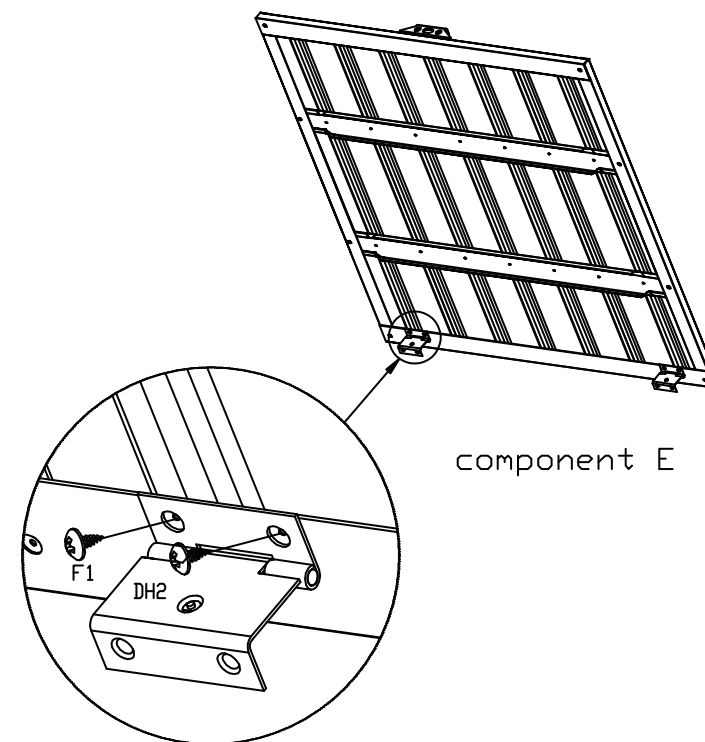





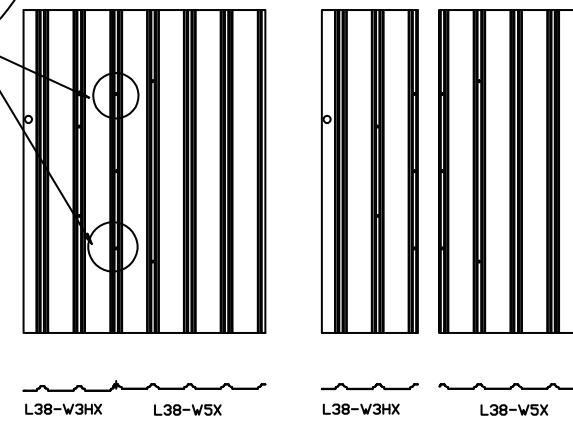
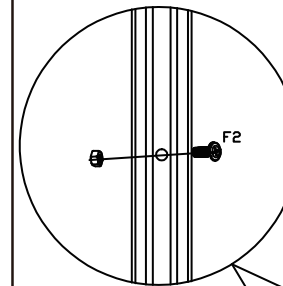

Door Assemble

DL

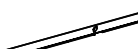
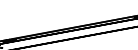

 View from the front, the vertical rod covers the horizontal rod. The larger hole is always covers over small ones.

3 Groups



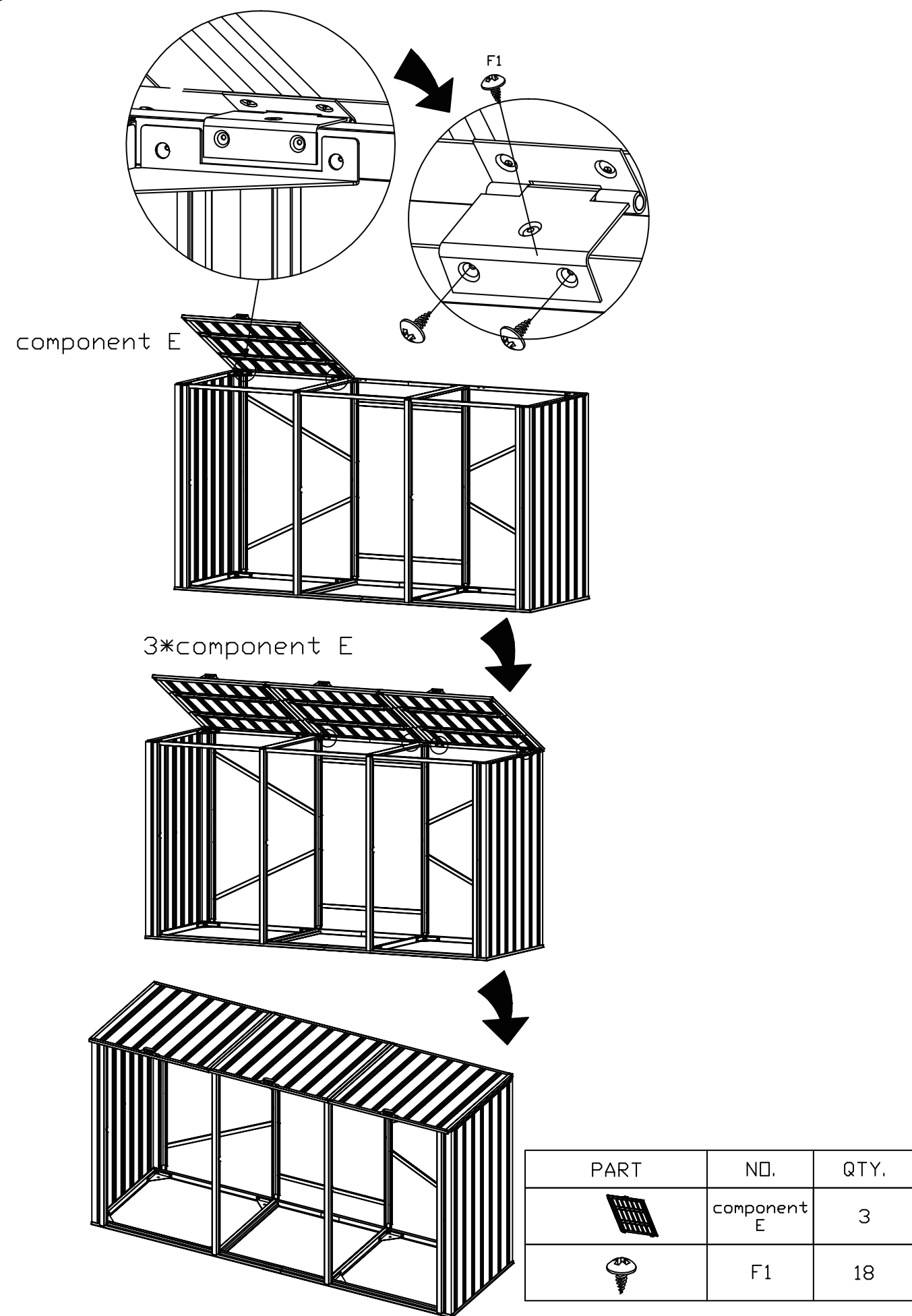
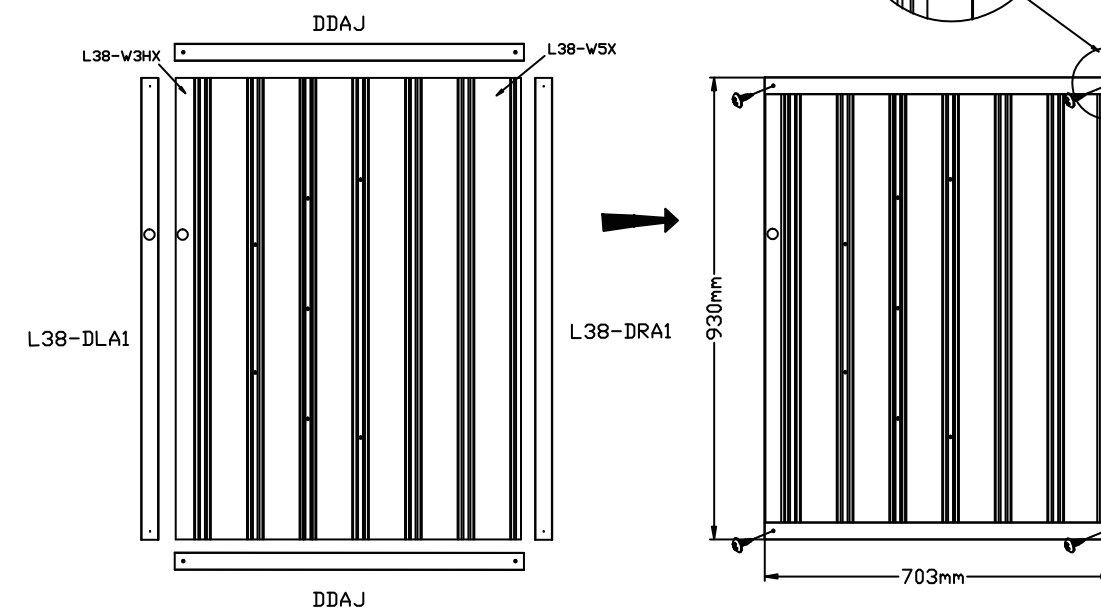
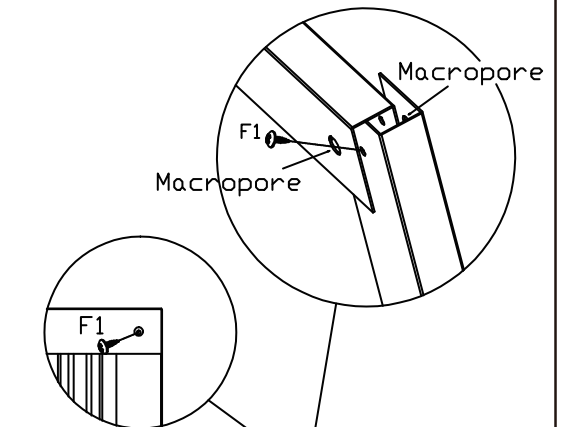



PART	NO.	QTY.
	L38-W5X	3
	L38-W3HX	3
	L38-DLA1	3
	L38-DRA1	3
	DDAJ	6
	F1	12
	F2	6

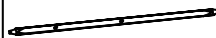

PART	NO.	QTY.
	component E	3
	F1	18

3 Groups

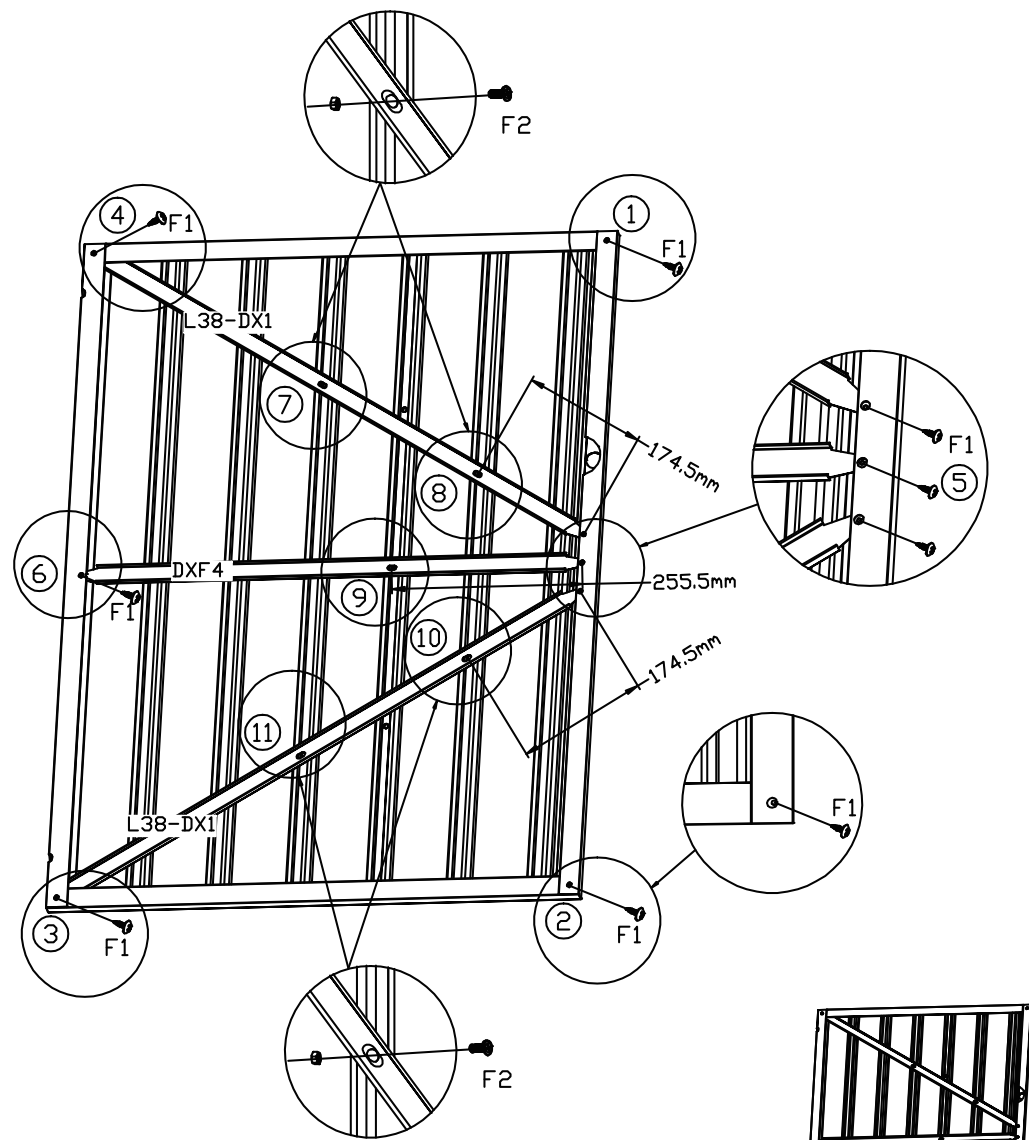

PART	NO.	QTY.
	L38-DX1	6
	DXF4	3
	F1	24
	F2	15

Attention: Installation sequence of screws ①→②→③→④→⑤→⑥→⑦→⑧→⑨→⑩→⑪





The cross pole L38-DX1 must be installed underneath DDAJ and L38-DRA1.

3 Groups

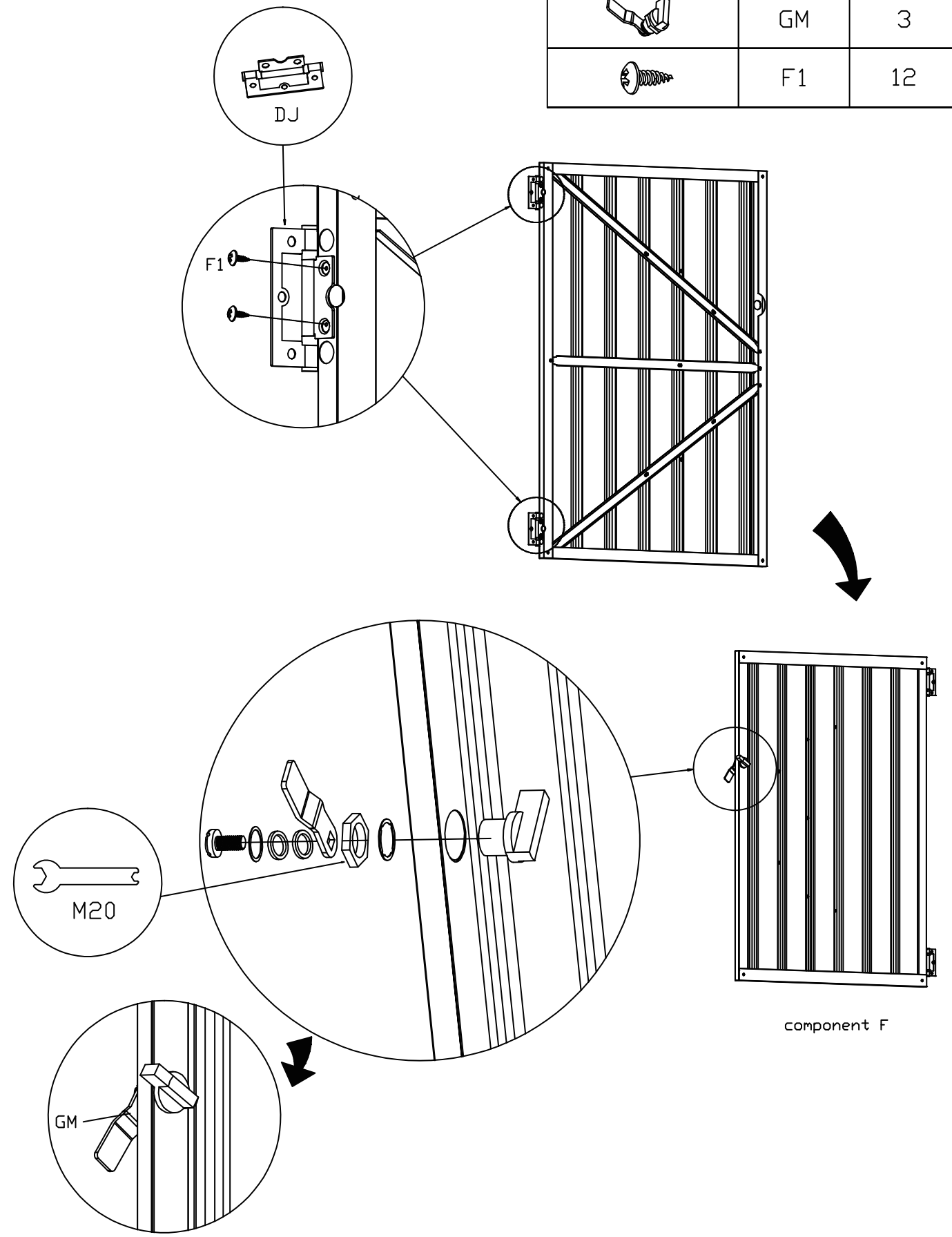
PART	NO.	QTY.
	DJ	6
	GM	3
	F1	12



PART	NO.	QTY.
	component F	3
	F1	18

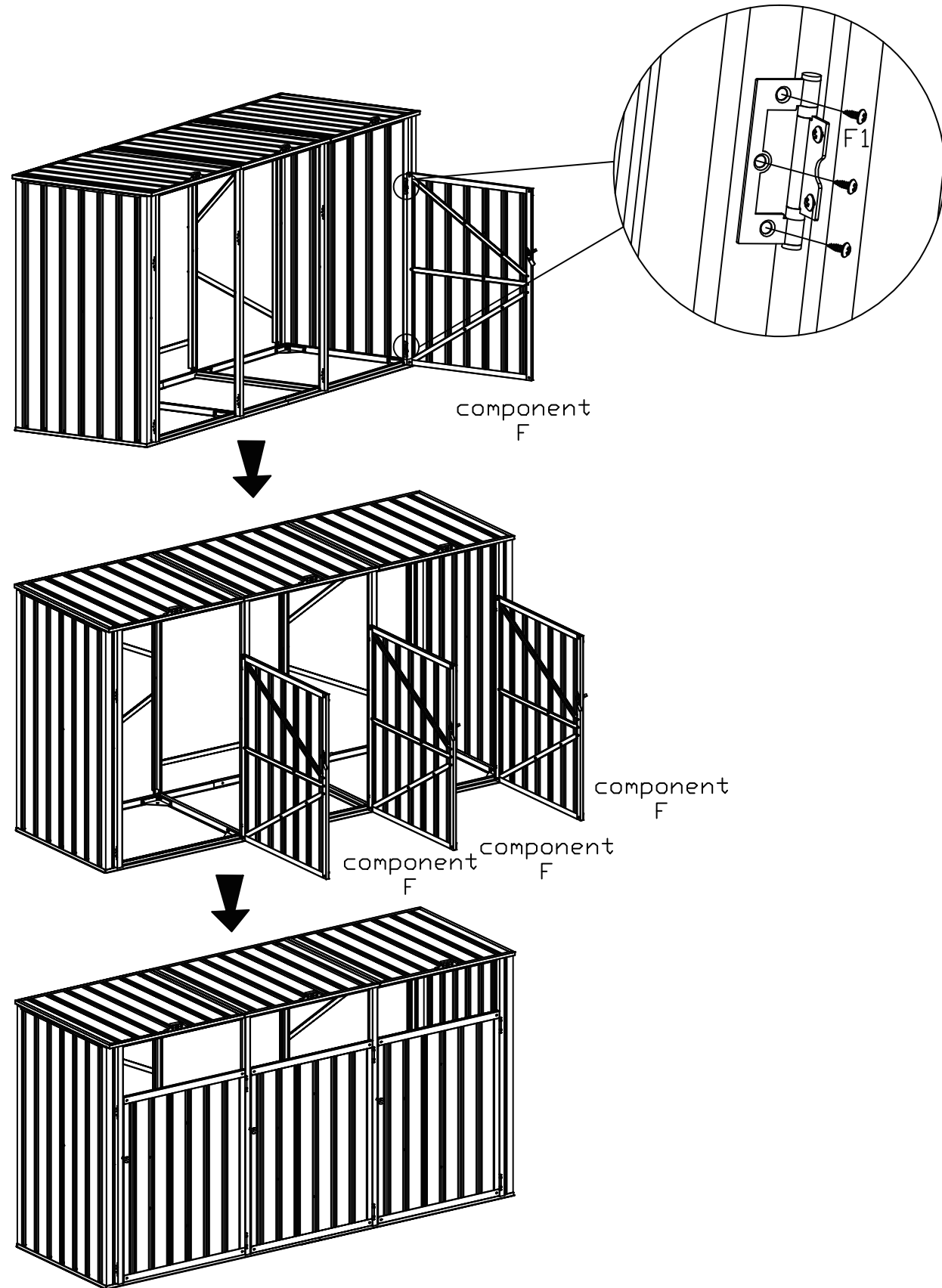

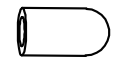
PART	NO.	QTY.
	SL	60

The exposed part of the top cover screw needs to be covered with a plastic protective cap.

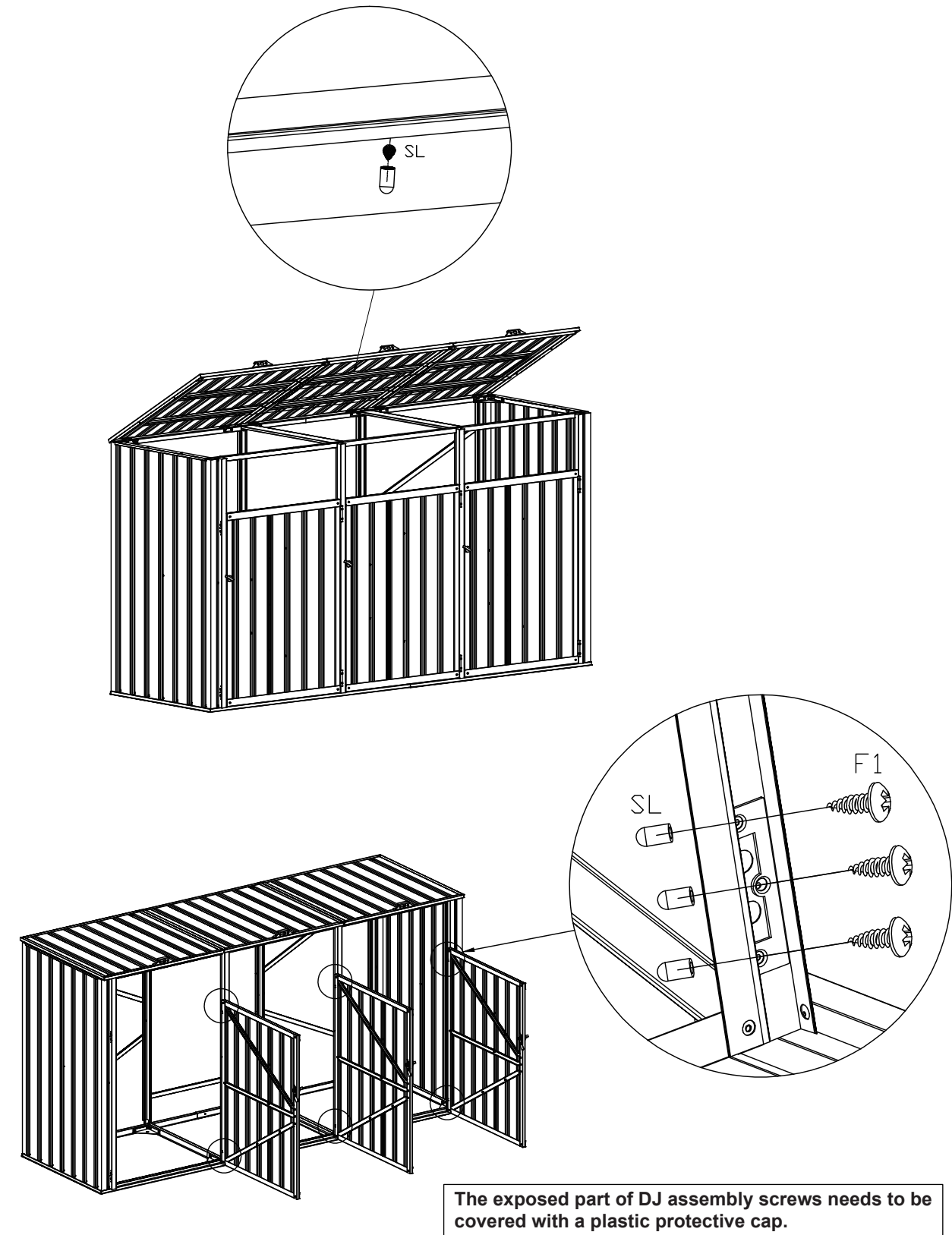

The exposed part of DJ assembly screws needs to be covered with a plastic protective cap.