

# INSTALLATION INSTRUCTION

## LED DISC

### FM-304

#### WARNING

IMPORTANT: NEVER attempt any work without shutting off the electricity.

- Read all instructions before installing.
- System is intended for installation by a qualified electrician in accordance with the National Electrical Code and local regulations.
- Go to the main fuse box, or circuit breaker. Place the main power switch in the "OFF" position and unscrew the fuse(s) or switch "OFF" the circuit breaker switch(es) that control the power to the fixture or room that you are working on.
- Place the wall switch in the "OFF" position.
- Supply conductors (Power Wires) Connecting the fixture must be rated minimum 90°C. If uncertain, consult an electrician.

#### CAUTIONS

- These luminaires (fixtures) are designed to meet the latest NEC requirements.
- Before attempting installation, check your local electrical code, as it sets the wiring standards for your locality.

#### INSTALLATION

##### *Over standard electrical junction box*

1. Twist lens cover counter-clockwise to remove from Disk Light.
2. Install cross bar to the 4" junction box with junction box screw.

#### ELECTRICAL CONNECTION

3. Provide electrical service according to the "National Electrical Code" or your local electrical code to the outlet box.
4. Connect supply wires to fixture wires and insulate with proper size wire nuts (**Fig 1**).
  - a) Connect incoming ground wire (green or bare) to fixture ground wire (green or bare).
  - b) Connect incoming common (white) wire to fixture common (white).
  - c) Connect incoming hot (typically black) wire to fixture black wire.
5. Attach the fixture to the cross bar and outlet box by fastening supplied 1½" outlet box screws through canopy keyholes. Make sure Disk Light is flush to the ceiling. (**Fig. 1**)
6. Twist the lens clockwise on disc light metal enclosure and lock the lens in place.

**Fig. 1**

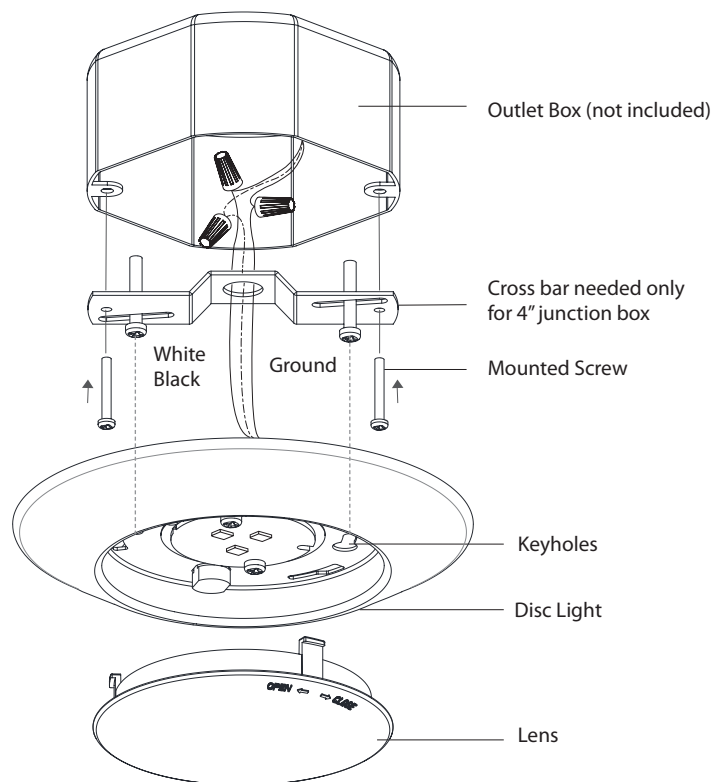

# INSTALLATION INSTRUCTION

## LED DISC

### FM-304

#### Installation onto existing 4 inch recessed housings

1. Twist lens cover counter-clockwise to remove from Disk Light.
2. Attach plastic insert to Disk Light using supplied 1/4" screws. **(Fig. 2)**
3. Detach the orange connector from socket adapter and insert black and white fixture wire into non-wired half of orange connector following color code marked. **(Fig. 3)**
4. Screw the socket adapter to socket in housing. **(Fig. 4)**
5. Plug the female connector of the disc light onto the male connector of the socket adapter assembly. **(Fig. 4)**
6. Push Disk Light through hole in plaster frame until flush with ceiling. Spring clip tension can be adjusted by bending spring clip.
7. Replace the lens back on to the Disk Light by twist the lens counter clockwise.

#### HOUSING COMPATIBILITY

| Brand     | Model                  |
|-----------|------------------------|
| Halo®     | H99T, H99RT, H99ICT    |
| All-Pro   | ET400, ET400R, ET400AT |
| Juno®     | TC1, TC1R, IC1P        |
| Capril    | R4, RR4, R4ASIC        |
| Lithonia® | L3, L3R                |
| Thomas®   | PS4, PS4RM, PS4ASIC    |

Fig. 2

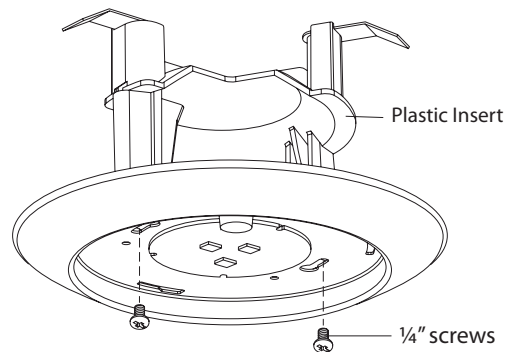

Fig. 3

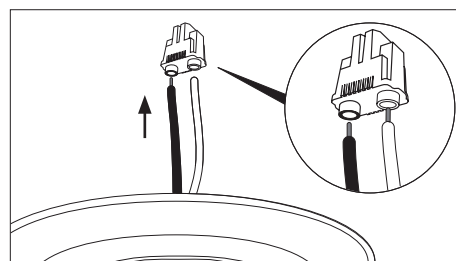

Fig. 4

