

ASSEMBLY INSTRUCTION

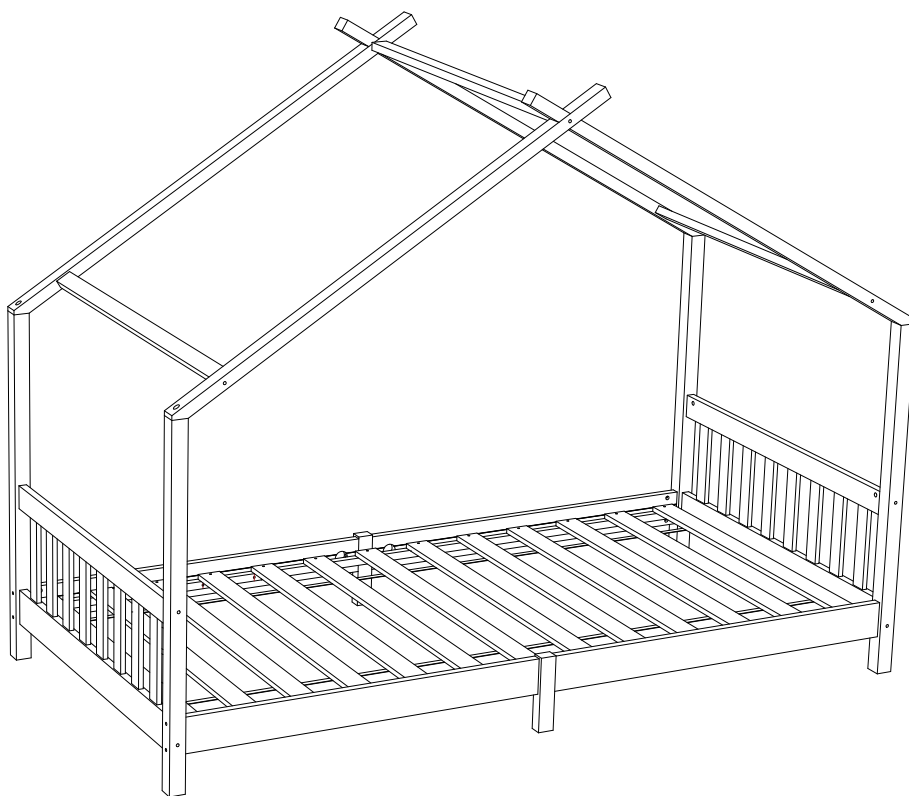

SAFETY WARNINGS

- 1.WARNING " high beds can present a serious risk of injury from strangulation if not used correctly. Never attach or hang items to any part of the bed that are not designed to be used with the bed, for example, but not limited to ropes, strings, cords, hooks, belts and bags"
- 2.WARNING " Children are not allowed to hang from the top of the bed by their hands"
- 3.Do not allow horseplay on the bed and prohibit jumping on the bed.
- 4.The bed must be used with mattress.The recommended size of the mattress to be used with the bed is **190cm x 90cm**.
- 5.The fastenings put in place on assembly should all be properly tightened and regularly checked.Retighten the fastenings as necessary.
- 6.2 people are recommended to finish.

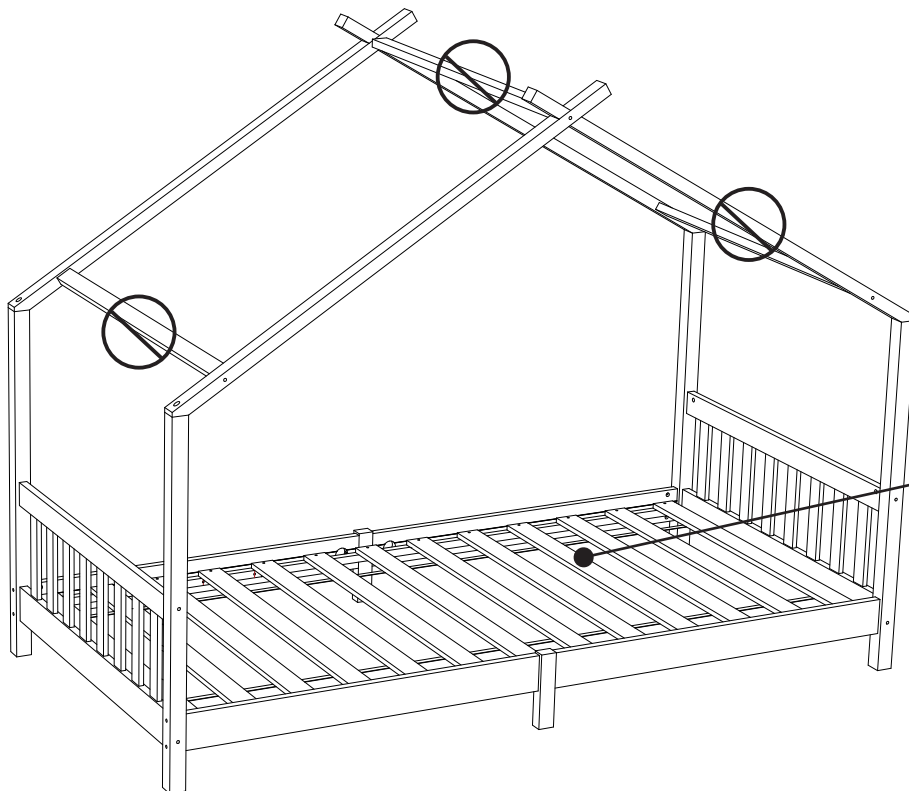







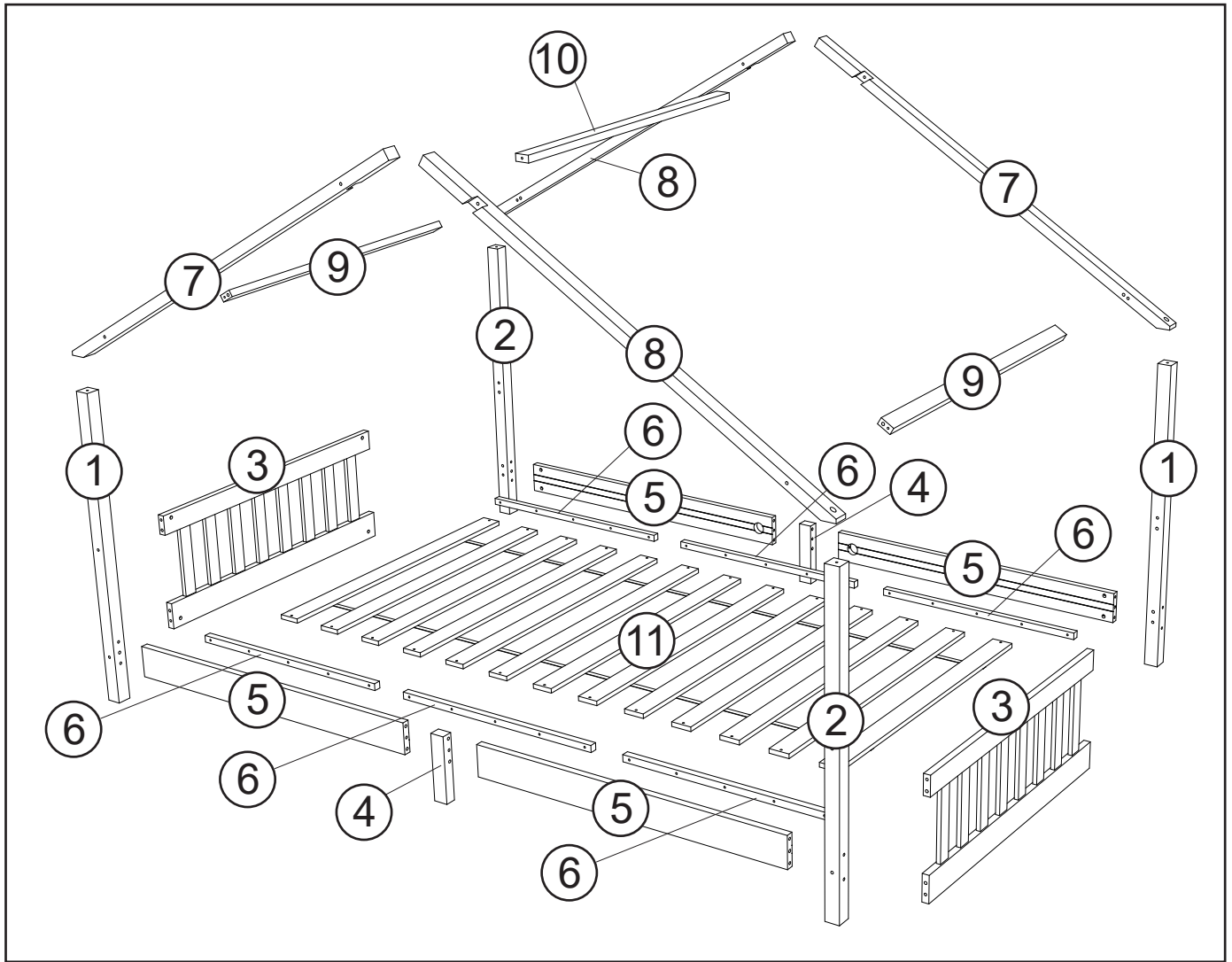





Max 100kg

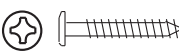
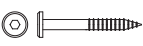

No Climbing!

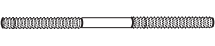

HARDWARE

A	  M6 x 80mm	16	H		4
B		16	I	 M4 x 30mm	56
C	 $\Phi 6 \times 50\text{mm}$	4	J		2
D	  $\Phi 8 \times 30\text{mm}$	24	K		1
E	 M6 x 140mm	2	L	 $\Phi 6 \times 80\text{mm}$	6
F		4	M		6
G		4			

**You will need a screwdriver(not provided)

Before that start...

Please check all hardware matches that list below.

We strongly advise that you do not use power tools.





We strongly advise that you tighten all screws to 80% and then re-tighten them to 100% after assembly.

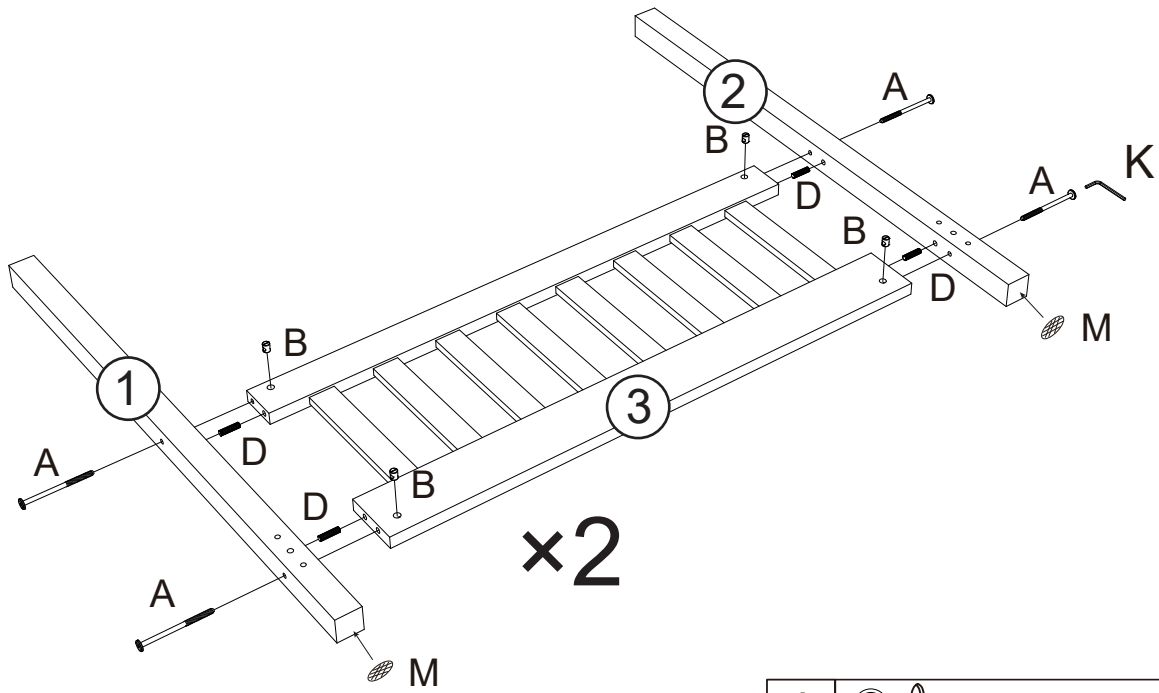

Do Not Use Power Tools







01

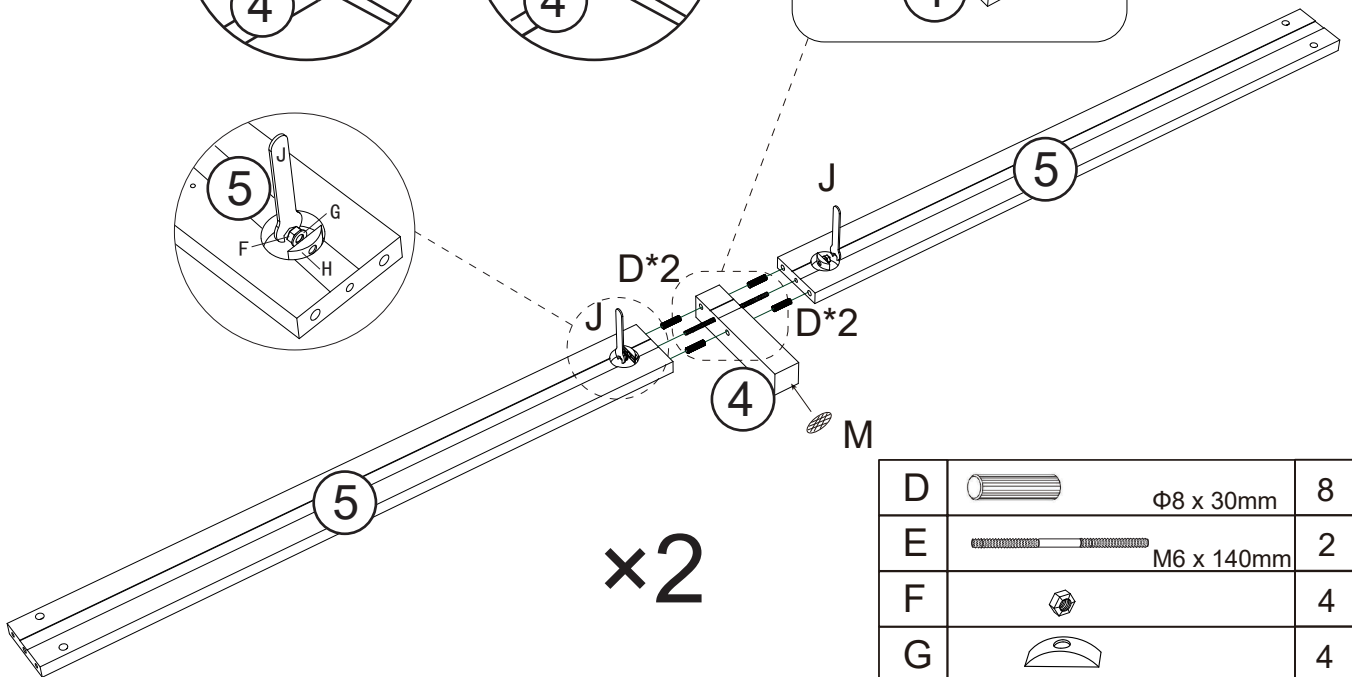
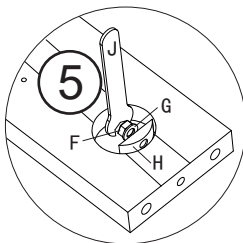
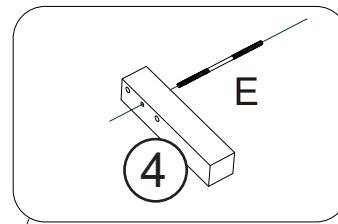
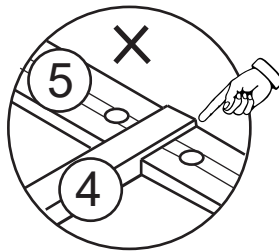
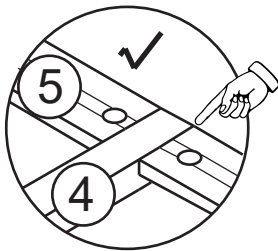

A	 M6 x 80mm	8
B		8
D	 $\Phi 8 \times 30\text{mm}$	8
M		4

02



D	 $\Phi 8 \times 30\text{mm}$	8
E	 M6 x 140mm	2
F		4
G		4
H		4
J		2
M		2

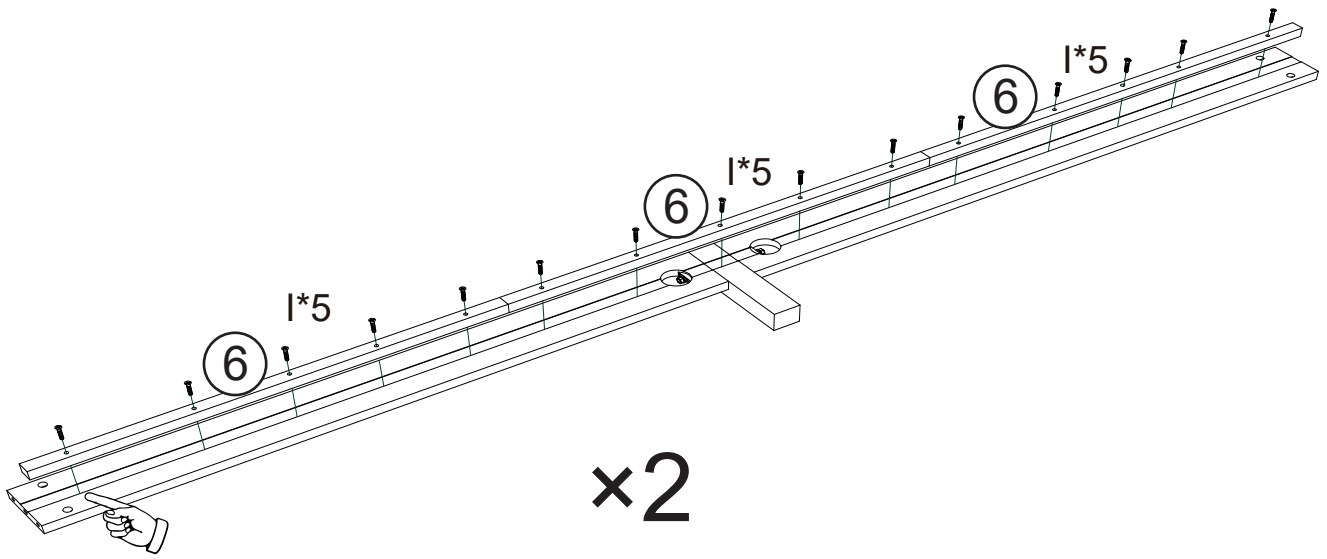

03

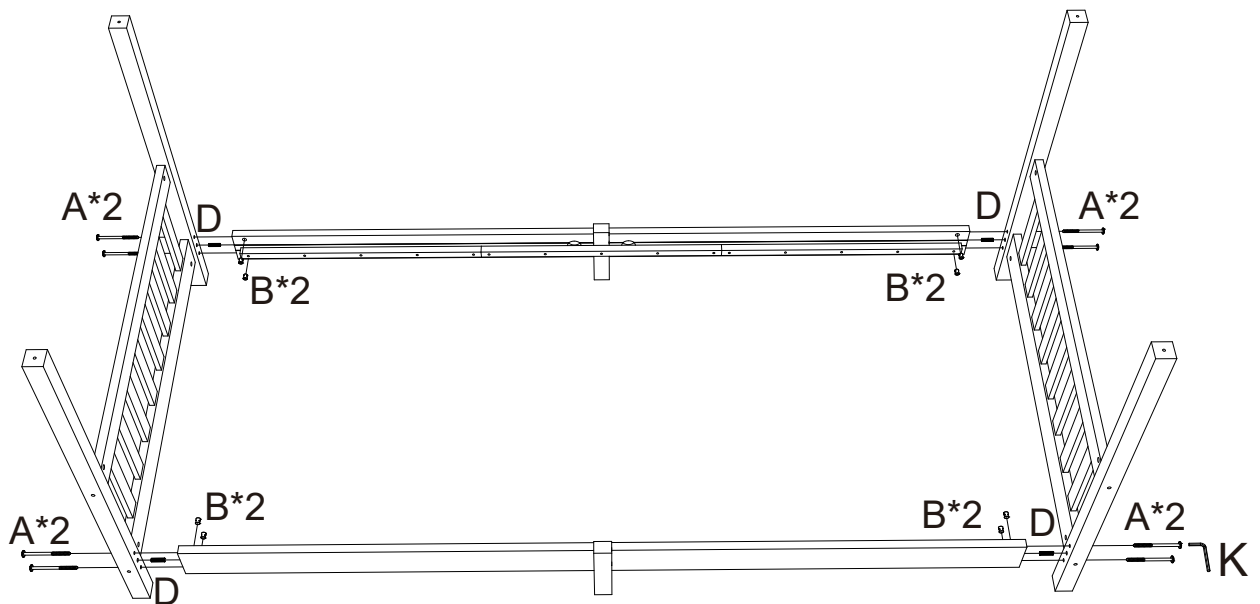

I		M4 x 30mm	30
---	---	-----------	----

04



A		M6 x 80mm	8
B			8
D		Φ8 x 30mm	4

05

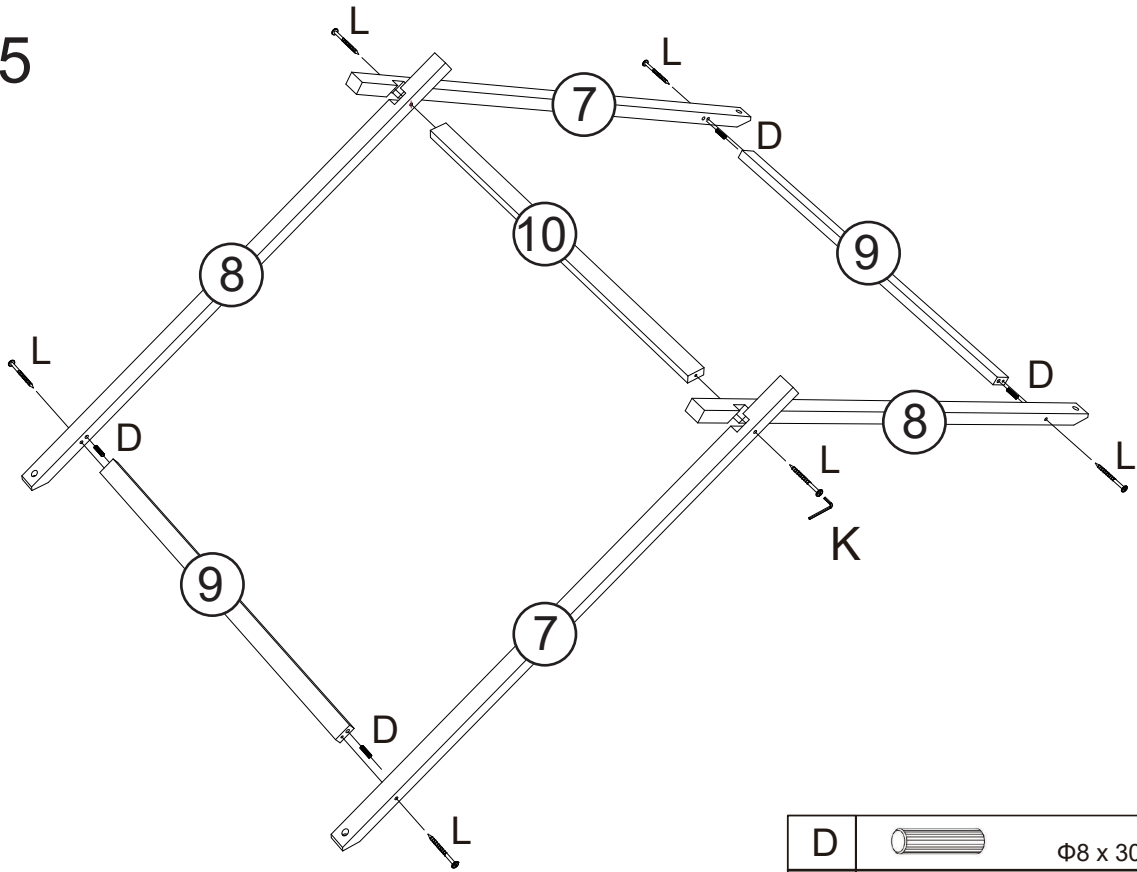

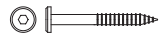
D		Φ8 x 30mm	4
L		Φ6 X 80mm	6

06

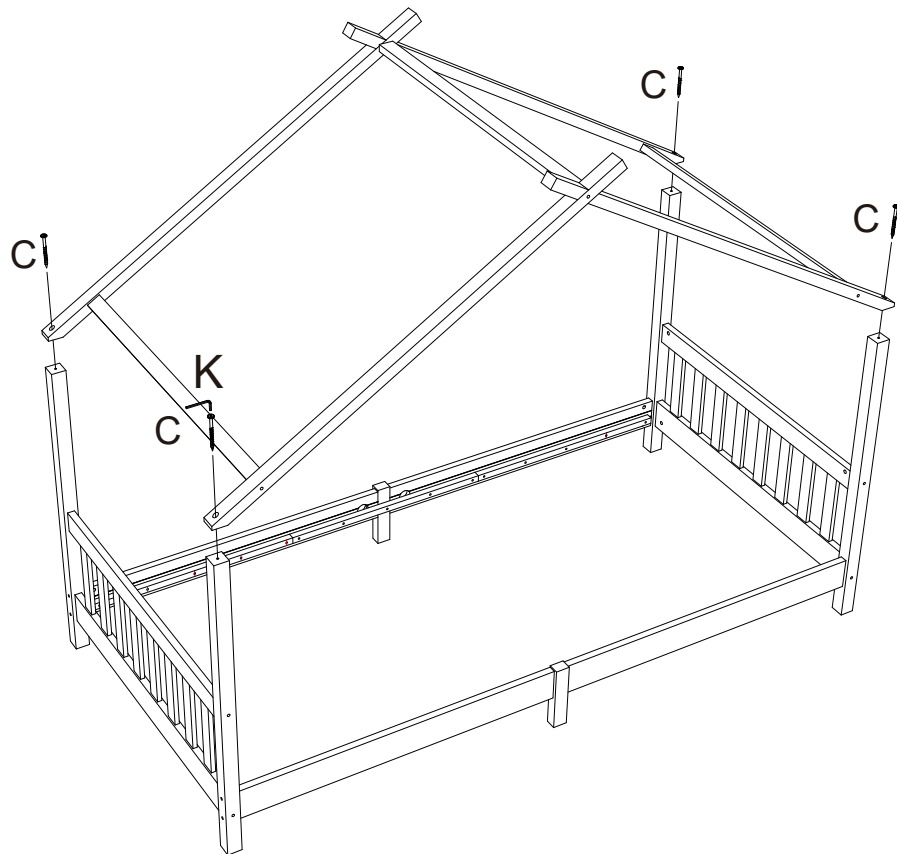

C		Φ6 X 50mm	4
---	---	-----------	---

07

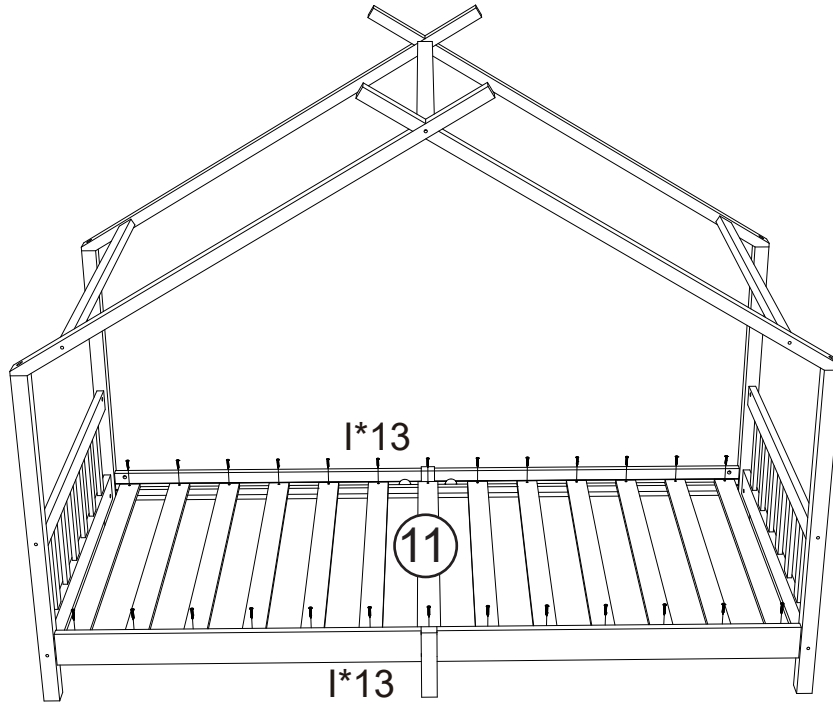

I			M4 x 30mm	26
---	---	---	-----------	----

08

