











# Assembly Instructions

**Caution : You must read this before you proceed**

## Care & Maintenance

- ⊘  ● Not for commercial use. For residential use only.
- ✓  ● Furniture may scratch floors. We recommend using furniture pads to protect your floors.
- ⊘  ● Do not put hot items directly on furniture surface.
- ⊘  ● Do not clean furniture with harsh cleansers or polish.
- ⊘  ● Do not place furniture under direct sunlight.
- ⊘  ● Do not place furniture near heating or cooling vents.
- ⊘  ● Do not write on furniture without a padded barrier to protect the surface.
- ⊘  ● Do not place furniture outside . For indoor use only.
- ⊘  ● Stains may be removed with mild soap solution and damp cloth.
- ⊘  ● Children should not climb or jump on the furniture.
- ✓  ● Dust and pick-up spills using a clean, non-colored, lint-free cloth.

Please look in carton for hardware packs an legs.

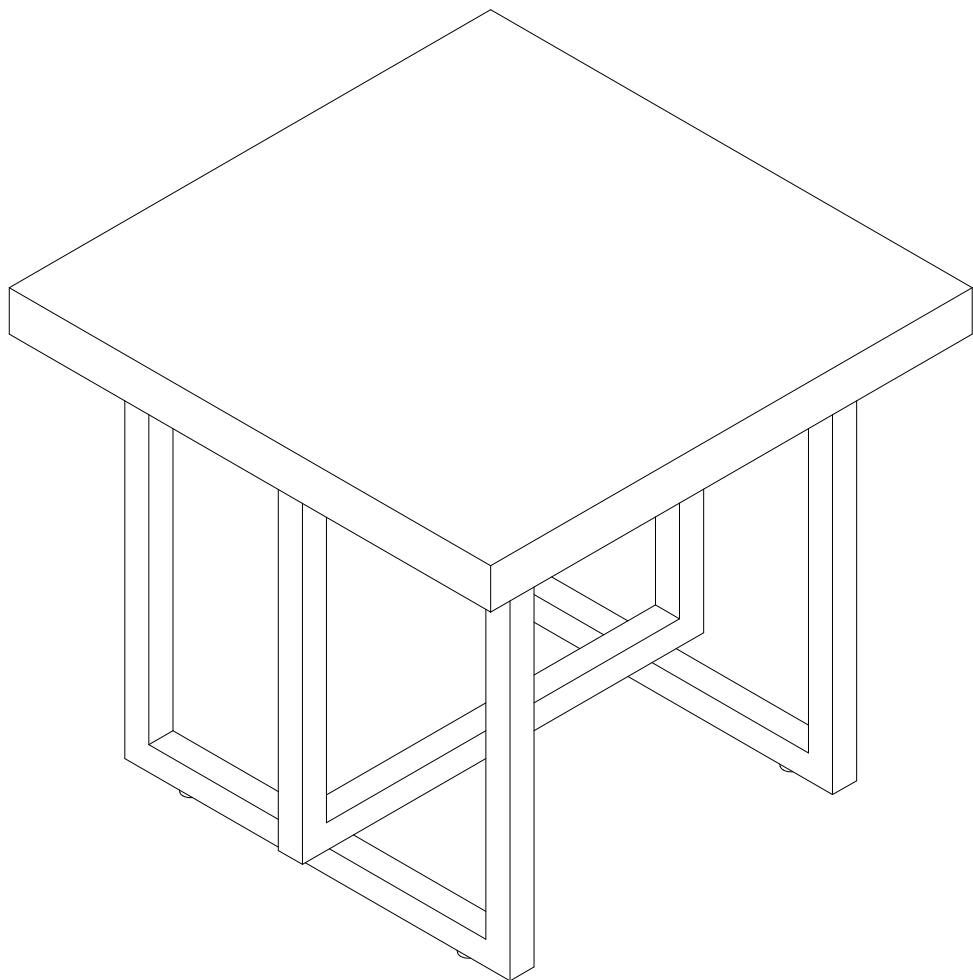

# END TABLE

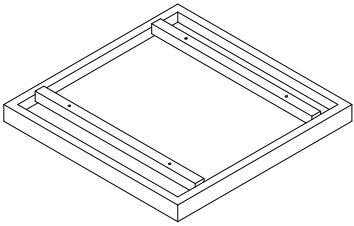
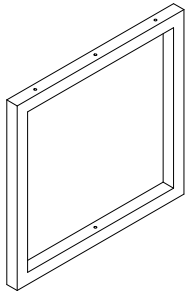
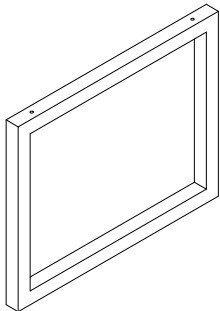

# Parts List

Label	Picture	Description	QTY
A		Table Top	1
B		Table Leg	2
C		Table Leg	1

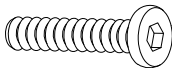
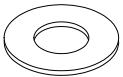
# Hardware

Label	Picture	Description	QTY
1		Bolt (M8*50mm)	9
2		Flat Washer	9
3		Hex Wrench	1
4		Adjustable Leveling Glide	4

# Assembly Preparation

Before  
Beginning  
Assembly:

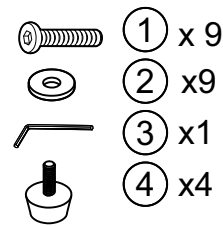
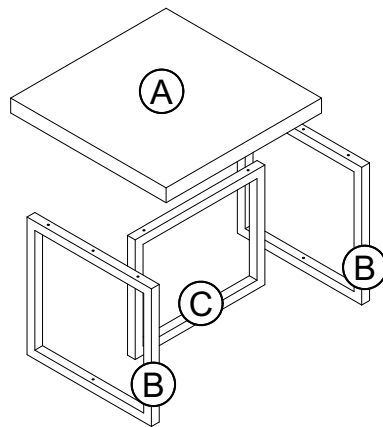

- Read instructions, cover to cover-



- Have 2 adults on hand for assembly-



- Do not assemble on flooring or carpet-

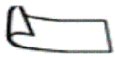

- Assemble on a clean non-marring surface (packing foam)-



- Save all packaging until finished-

# Assembly Preparation

Overview

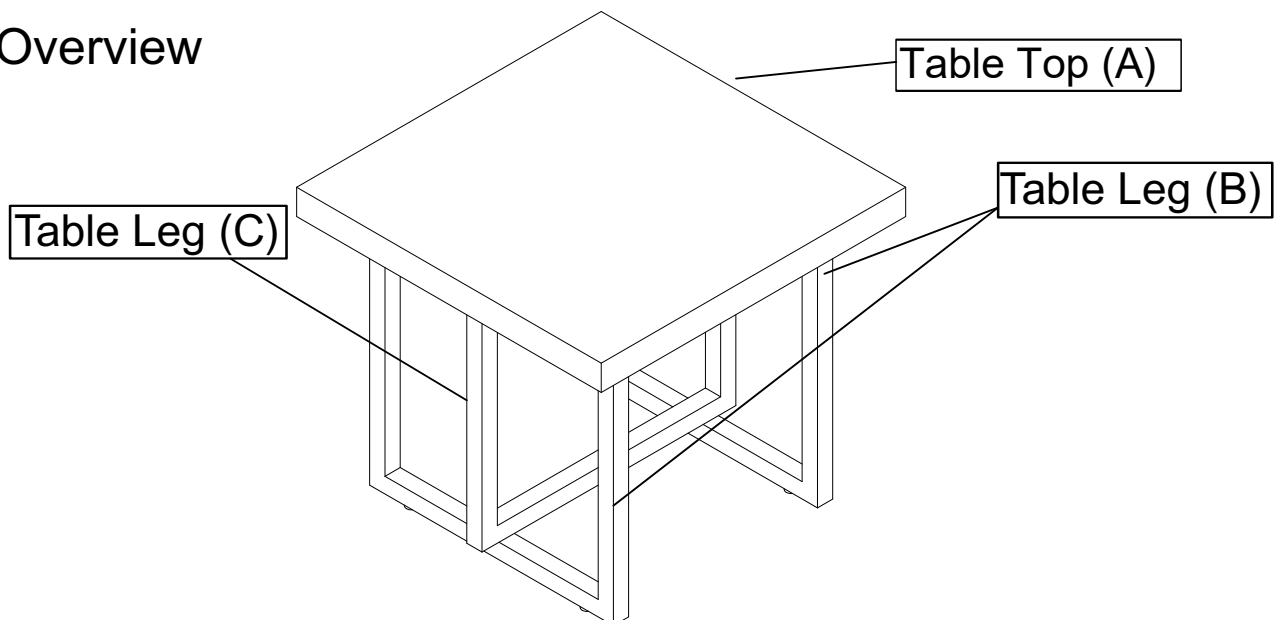

This end table has multiple parts and may require up to some 15 minutes to assemble. To give you an overview of the end table parts, the above picture is to help you put the various parts into perspective. Please read through the instructions below to familiarise yourself with the parts and steps before assembly.

## Step 1

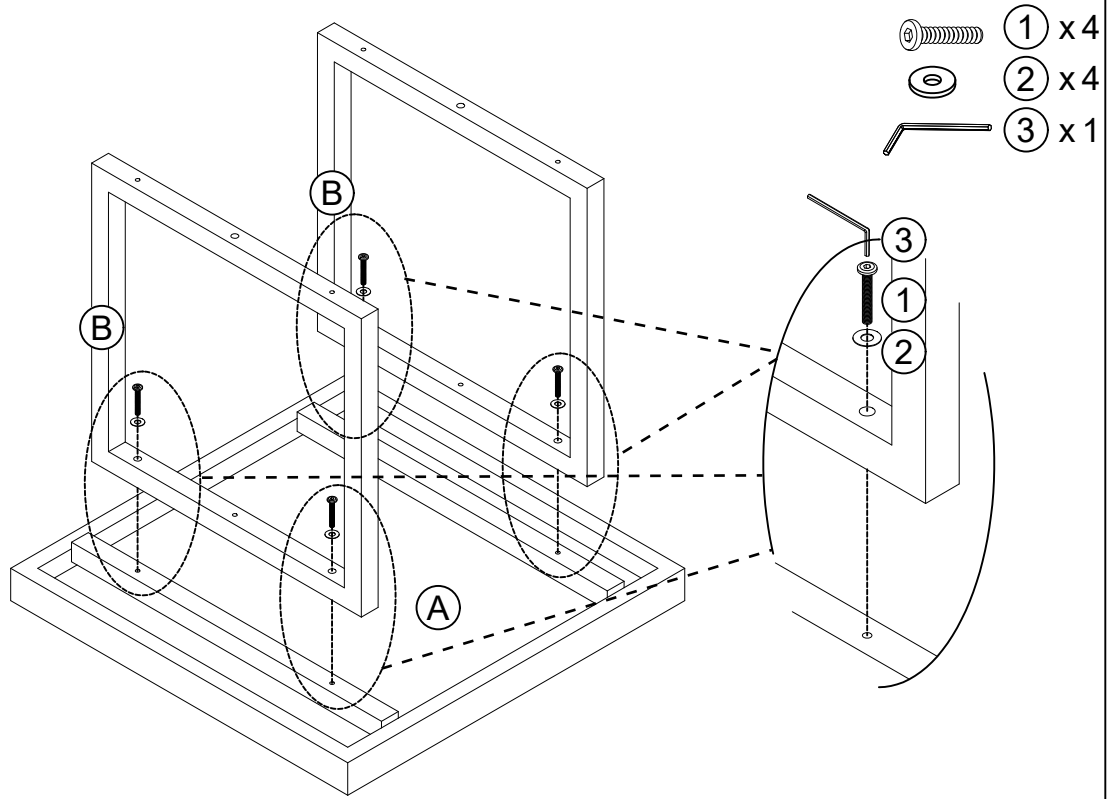

Attach table leg(B) to table top(A) with bolt(①) and flat washer(②).

## Step 2

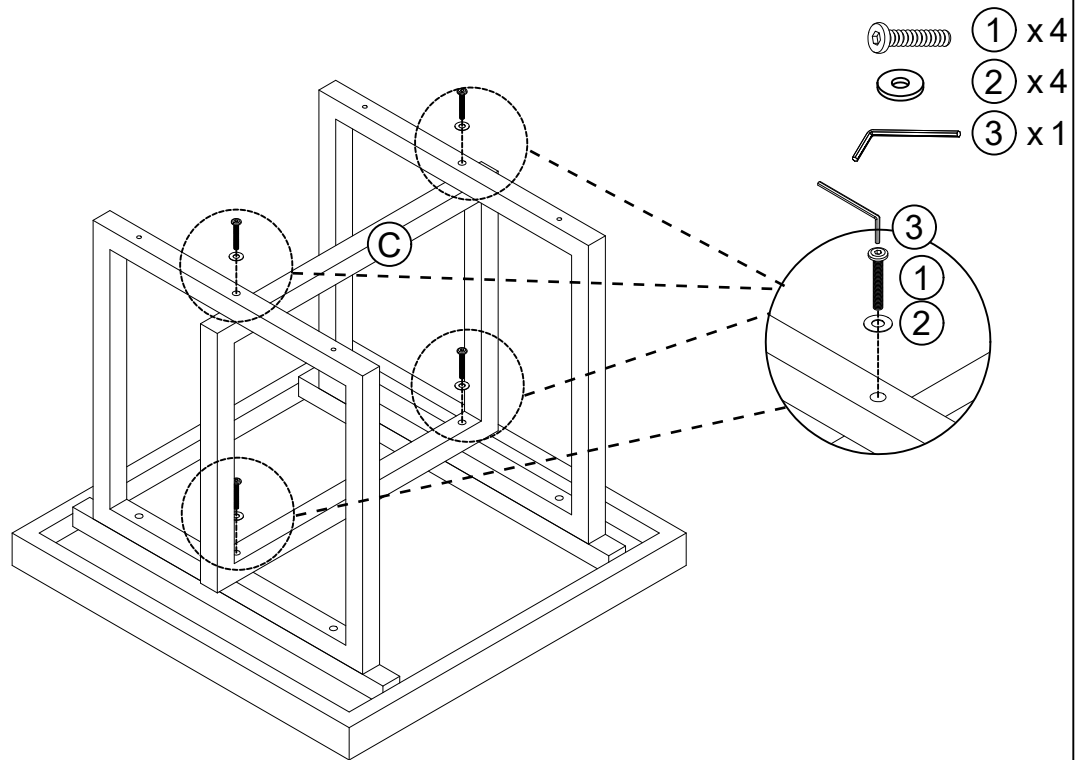

Attach table leg(C) to table leg(B) with bolt(①) and flat washer(②).

## Step 3

 ④ x 4

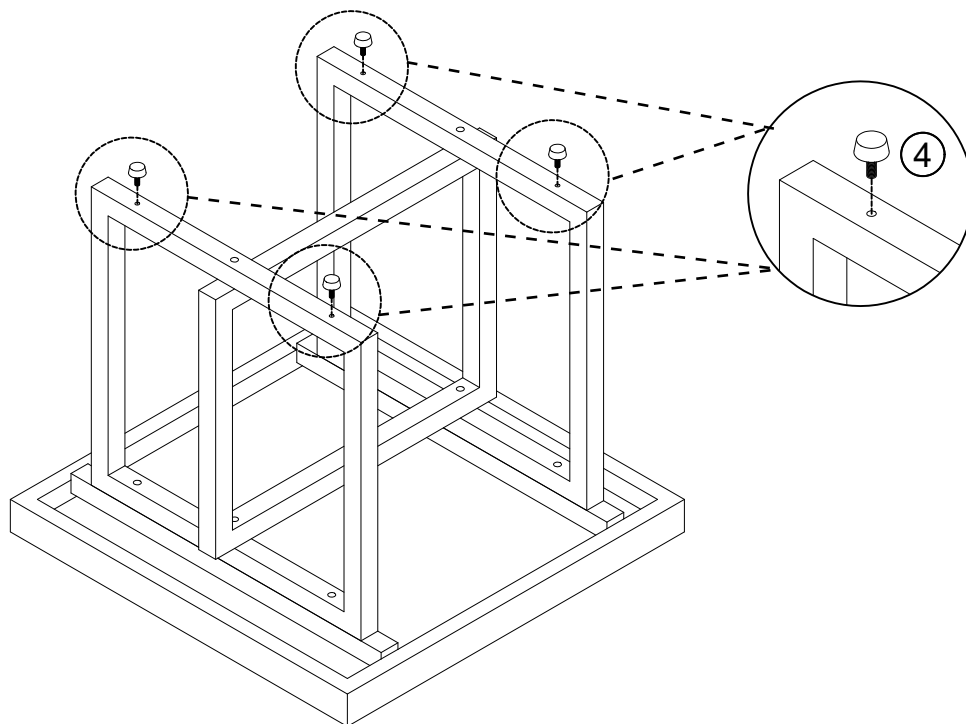

Screw adjustable leveling glide(④) to table leg(B).

## Step 4

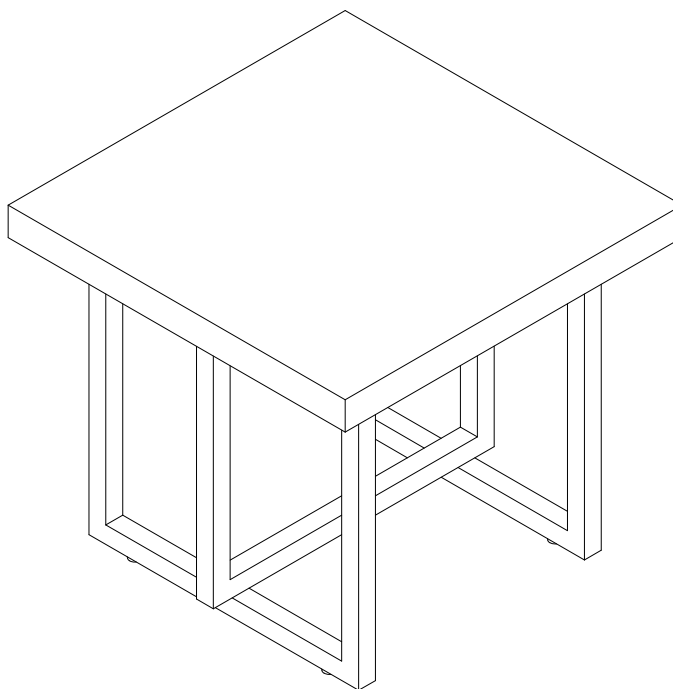

The table is ready to use.

## ”Questions & Answers about Proposition 65

- What is Proposition 65?

Proposition 65 requires businesses to provide warnings to Californians about significant exposures to chemicals that cause cancer, birth defects or other reproductive harm. These chemicals can be in the products that Californians purchase, in their homes or workplaces, or that are released into the environment. By requiring that this information be provided, Proposition 65 enables Californians to make informed decisions about their exposures to these chemicals.

Proposition 65 also prohibits California businesses from knowingly discharging significant amounts of listed chemicals into sources of drinking water.

Proposition 65 requires California to publish a list of chemicals known to cause cancer, birth defects or other reproductive harm. This list, which must be updated at least once a year, has grown to include approximately 900 chemicals since it was first published in 1987.

- What types of chemicals are on the Proposition 65 list?

The list contains a wide range of naturally occurring and synthetic chemicals that include additives or ingredients in pesticides, common household products, food, drugs, dyes, or solvents. Listed chemicals may also be used in manufacturing and construction, or they may be byproducts of chemical processes, such as motor vehicle exhaust. ”