

FLEXSTEEL®

W1031 / W1032-860

Dresser

IMPORTANT

Carefully remove all parts from the carton, and put them individually on a soft cloth to prevent damage to the parts.

We have taken great care in the design of this product and request that you carefully and accurately follow our assembly instructions to ensure proper set-up.

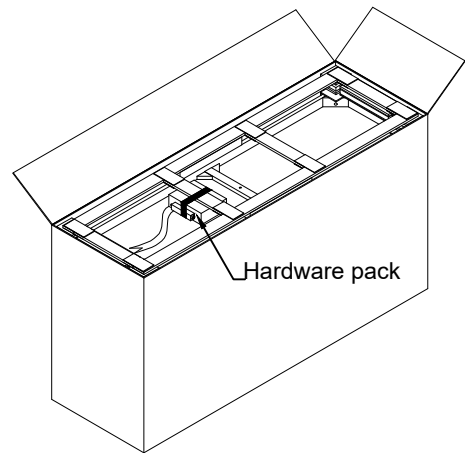
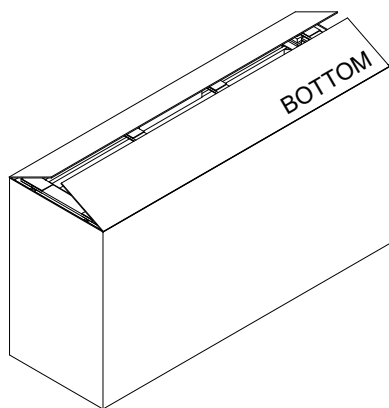
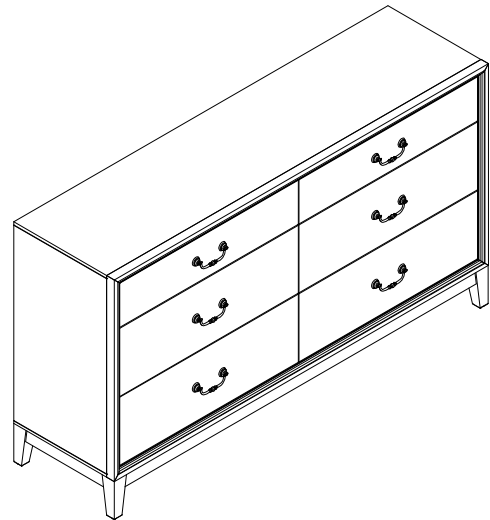

Part List

Assembly Instructions 1/3

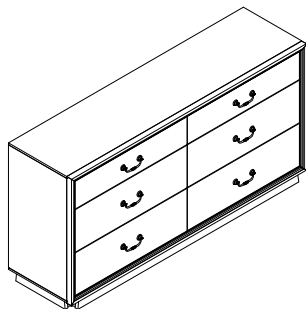

A. Box
1 piece



B. Leg
4 pieces



C. Support Leg
1 piece

Hardware List

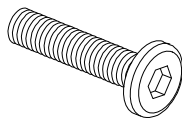

Bolt
Ø5/16" x 18 UNC x 2"
8 pieces



Spring Washer
Ø5/16" x 1.5mm
8 pieces



Flat Washer
Ø5/16" x Ø19 x 1.5mm
8 pieces

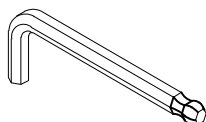

Hex Key
5/32"
1 piece

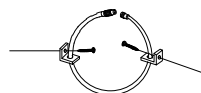

Anti-Tipping
1set

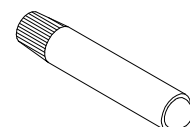

Touch-up Pen
1 piece

FLEXSTEEL®

Assembly Instructions 2/3

IMPORTANT NOTES

- Do not tighten up all the bolts until each part is properly assembled.
- Keep the Hex Key in a safe place as you may need to tighten up the bolts in the future.
- Use a soft cloth between these parts and the floor.
- We recommend this product be assembled by at least two adults.

STEP 1

Open carton box from the bottom, and take out the assembly parts where it is located - Leg (B), Support Leg (C) and Hardware pack. (See Figure 1)

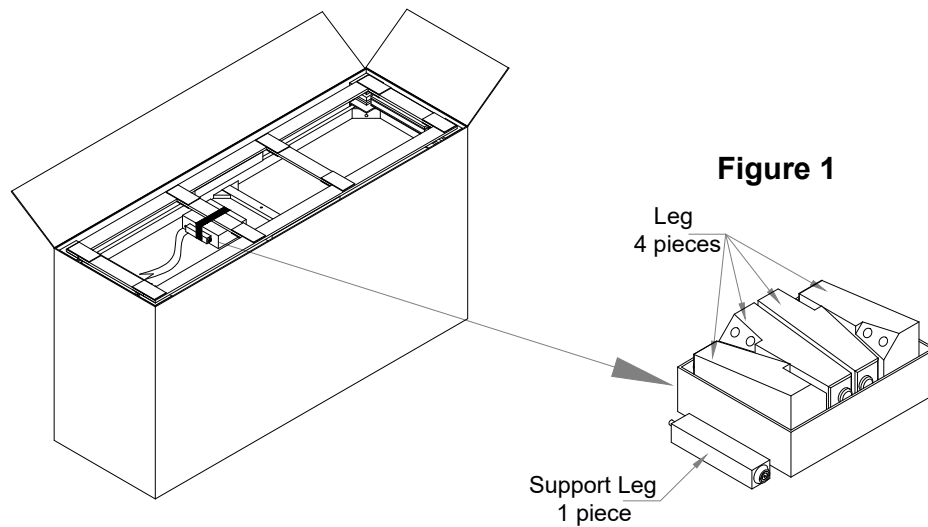

STEP 2

Fix Legs (B) to each corner of the Dresser (A). Insert Bolts, Spring Washers, Flat Washers and fully tighten bolts with Hex Key (See Figure 2). Connect the Support Leg (C) to Dresser (A) by rotating it clockwise by hand until tight. (See Figure 3)

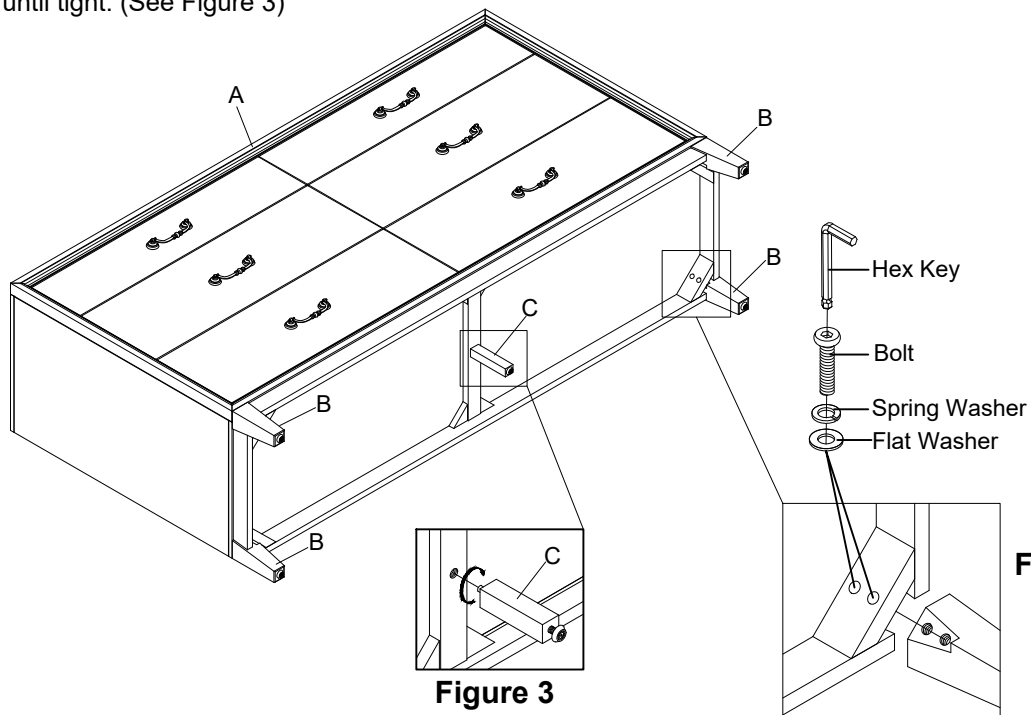

FLEXSTEEL®

Assembly Instructions 3/3

IMPORTANT NOTES

- Do not tighten up all the bolts until each part is properly assembled.
- Keep the Hex Key in a safe place as you may need to tighten up the bolts in the future.
- Use a soft cloth between these parts and the floor.
- We recommend this product be assembled by at least two adults.

STEP 3

Adjust the levelers on the legs until the furniture is leveled. (See Figure 4)

The drawers can be adjusted up or down as necessary using the adjustment knob under the drawers on the drawer glides. (See Figure 5)

Pull out the slide latch at the bottom of the drawer and lift the drawer up to remove it. (See Figure 6)

NOTE: There is a tip restraint kit provided on the back of this product. Take care to read the instructions thoroughly and install it immediately when placed in the home.

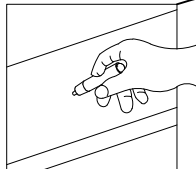
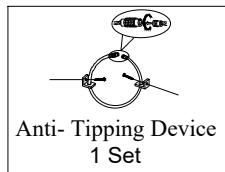

Use the touch-up pen on any minor finish imperfections. Shake the pen well before using. Color match may vary slightly due to natural wood and finish variations. Test on an inconspicuous area before use.

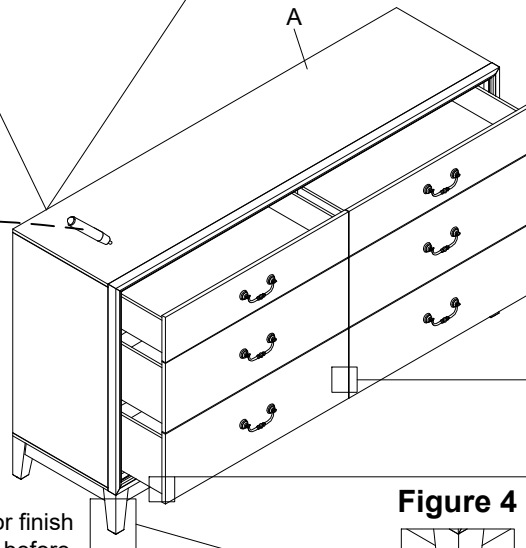
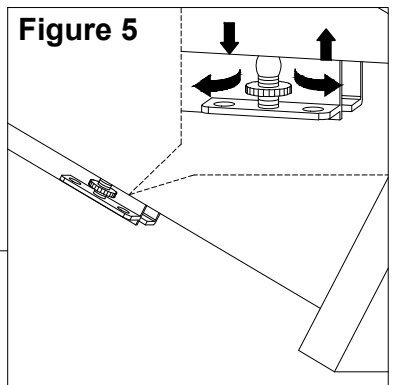
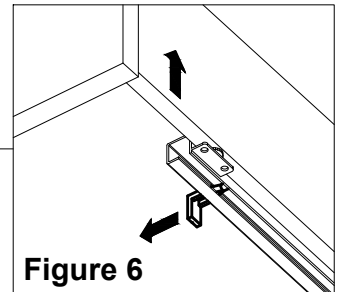

Figure 4

Adjustable leveler



CARE INSTRUCTIONS

- To avoid scratches, do not place sharp or jagged objects directly on the cabinet.
- Do not place hot items directly on the cabinet.
- Use placemats or trivets under hot items and coasters under beverages to prevent marks and stains.
- Avoid the use of harsh chemicals or abrasive cleaning materials.
- Wipe the cabinet clean with a soft, dry cloth after each use.
- Wipe up spills quickly with a soft, dry cloth.

Flexsteel Industries, Inc.

For Parts or Customer Service call

toll-free:

1-888-415-3979

Monday-Friday

8:00 a.m. -5:00 p.m.

(Central Time)

Email:

customersolutions@flexsteel.com

www.flexsteel.com