

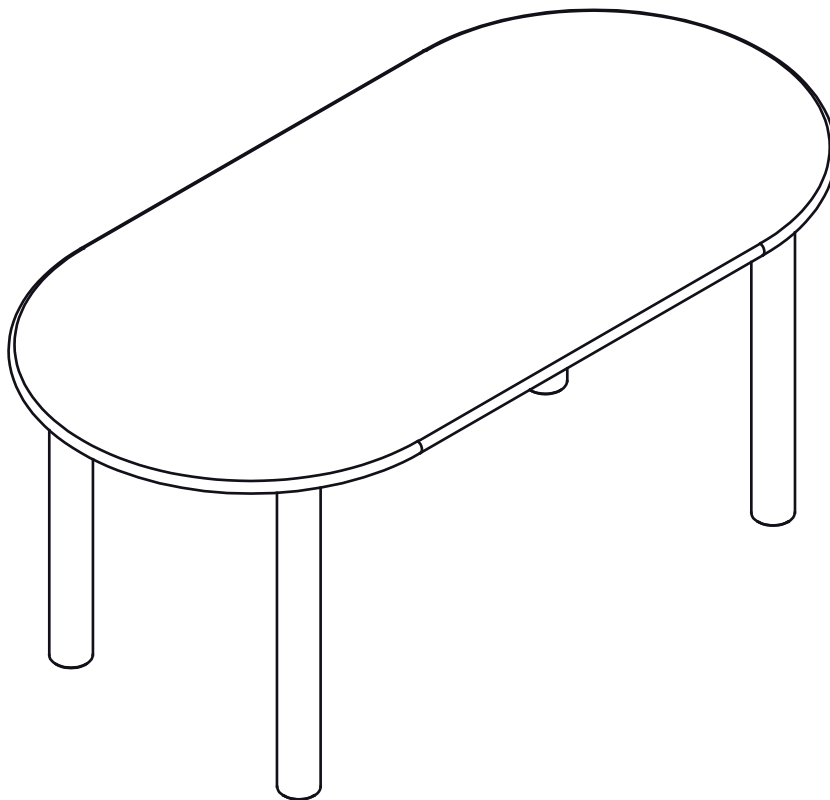

CROSLEY

FURNITURE



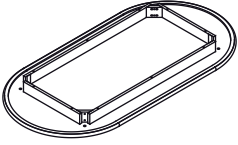

Dining Table CF2016



PART LIST



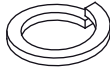

<div data-bbox="118 138 165 192" style="border: 1px solid black; padding: 2px;">A</div> 	<div data-bbox="402 138 450 192" style="border: 1px solid black; padding: 2px;">B</div> 
<p>Table Top 1 PC</p>	<p>Leg 4 PCS</p>

HARDWARE LIST

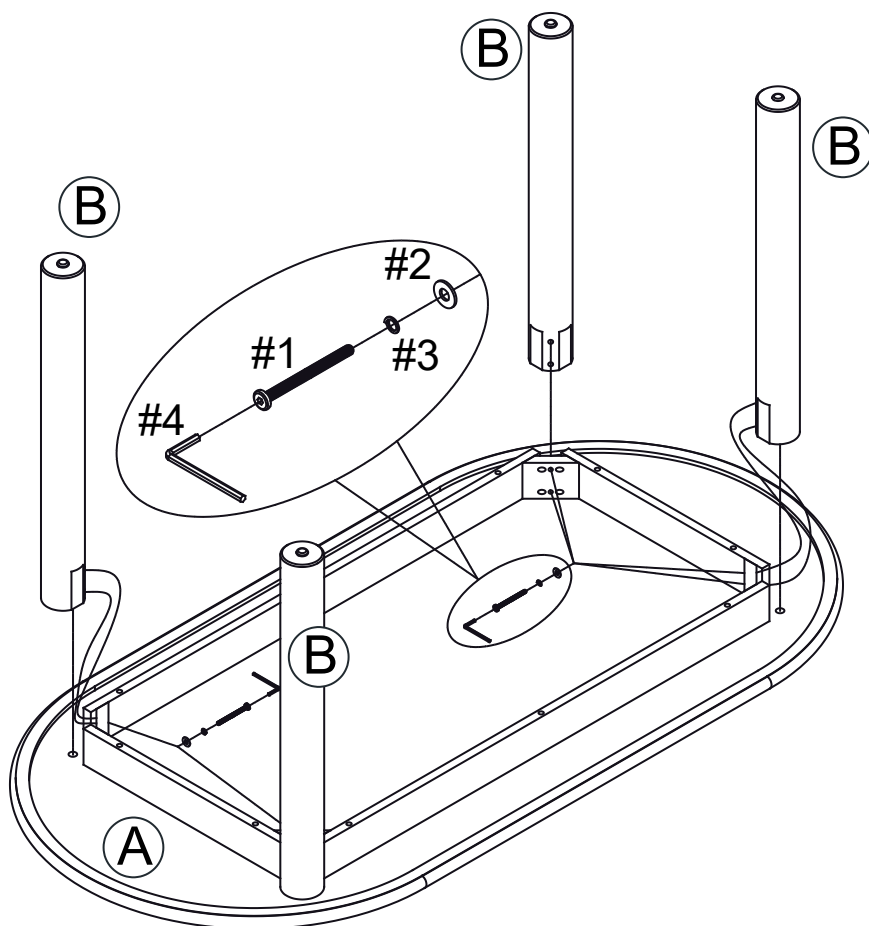
<div data-bbox="118 741 165 795" style="border: 1px solid black; padding: 2px;">#1</div>  <p>Ø1/4"*2"</p>	<div data-bbox="402 741 450 795" style="border: 1px solid black; padding: 2px;">#2</div> 	<div data-bbox="684 741 732 795" style="border: 1px solid black; padding: 2px;">#3</div> 	<div data-bbox="967 741 1015 795" style="border: 1px solid black; padding: 2px;">#4</div>  <p>4mm</p>
<p>Bolt 8 PCS (Extra 1)</p>	<p>Flat Washer 8 PCS (Extra 1)</p>	<p>Spring Washer 8 PCS (Extra 1)</p>	<p>Allen Wrench 1 PC</p>

Step 1. Attach legs (part B) to table top (part A) using bolts (part #1), flat washers (part #2), spring washers (part #3) and allen wrench (part #4).



- | | | |
|----|---|-----|
| #1 |  | x 8 |
| #2 |  | x 8 |
| #3 |  | x 8 |
| #4 |  | x 1 |

Step 2. Carefully turn unit upright.

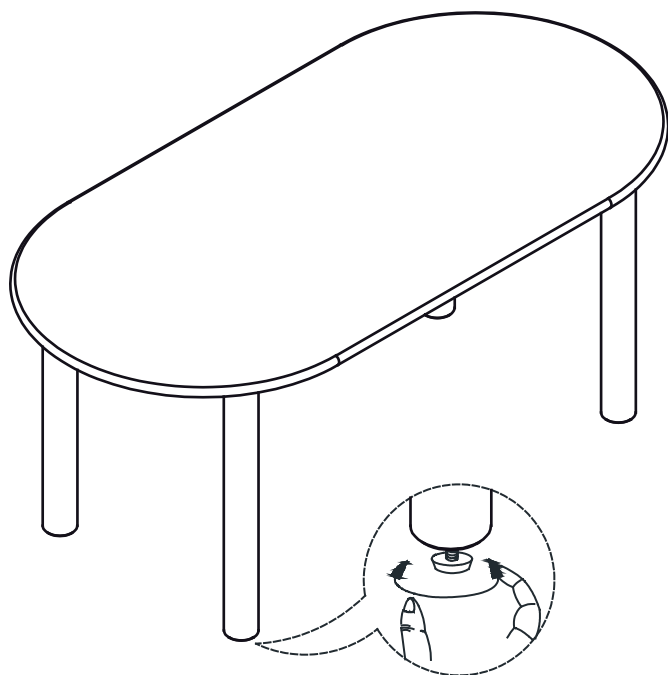

Note: It is important to adjust levelers once fully assembled and upright. Extend adjustable leveler until it's firmly in contact with the floor. If relocating, adjust leveler as needed until it's firmly in contact with the floor in new location.