

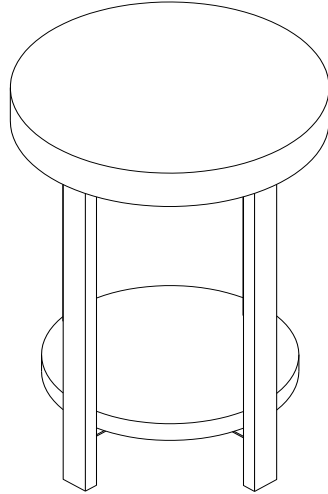



Round End Table





Thank you for purchasing our Round End Table. **We have found it helpful to have a second person present in at least one step of the assembly.**

Assembly Instructions

Lay out all parts on a "non-abrasive" surface to avoid scratching furniture.

NO.	DRAWING	DESCRIPTION	QTY.
A		TOP	1
B		SHELF	1
C		METAL BASE	2

NO.	DRAWING	DESCRIPTION	QTY.
D		M6*20mm BOLT	8
E		WRENCH	1

Step 1

Read through these instructions thoroughly before beginning assembly. We have found this to be of great value when first assembling this product.

Step 2

Remove all parts and hardware from packing material. Wooden pieces should be placed on a non

abrasive surface (like the carton or carpet) to prevent damage to the finish.

Step 3

Lay Top (A) upside down and "nest" 2 Side Panels (C) and attach to Top (A) by using 4 6M x 20mm Bolts (D).
DO NOT TIGHTEN FIRMLY AT THIS TIME.

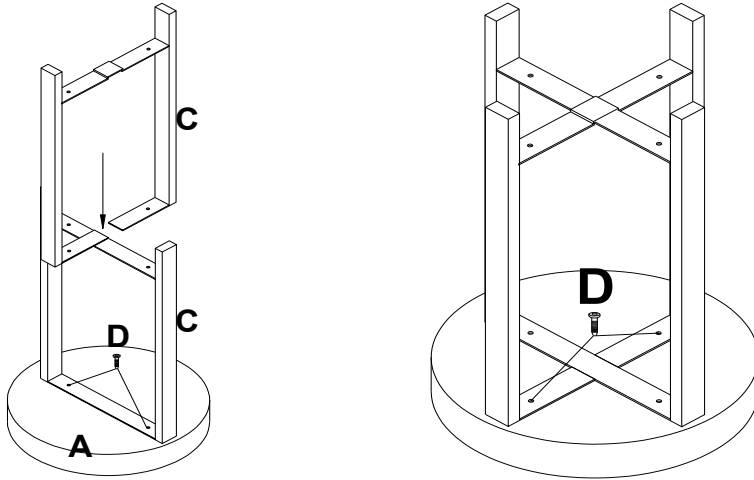

Step 4

Note: It will help to have a second person at this time to assist in assembly.

Lay on side and attach Shelf (B) to Side Panels (C) using 4 6M x 20mm Bolts (D).

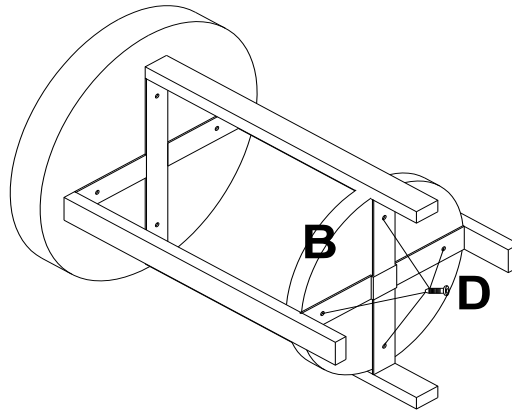

TIGHTEN ALL BOLTS FIRMLY AT THIS TIME.

CARE

Clean with mild soap and wipe dry.
