

# CH-BR31-H55

## [Chain BR31-H] Brass Rectangle Chandelier Chain

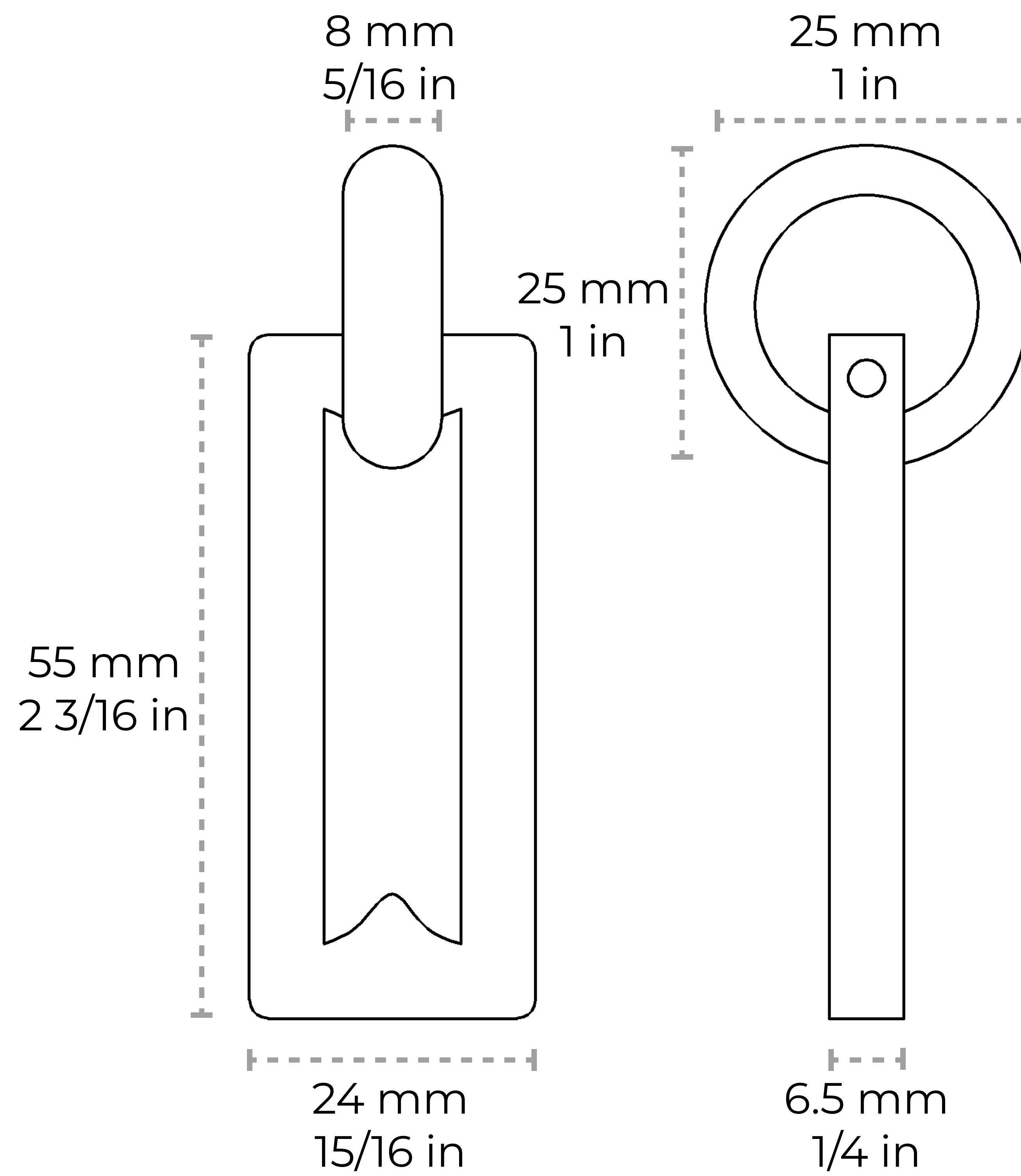

|                              |   |
|------------------------------|---|
| Material                     | Brass   |
| Welding Type                 | Hinge   |
| Max Load                     | 103 lbs   |
| Weight per Foot              | 0.5 lbs/ft  |
| Main Link Measurements       | Length: 55 mm 2 3/16 in<br>Width: 24 mm 15/16 in<br>Diameter: 6.5 mm 1/4 in |
| Connecting Link Measurements | Length: 25 mm 1 in<br>Width: 25 mm 1 in<br>Diameter: 8 mm 5/16 in           |

### Contact:

1-360-392-8121

<https://www.rchhardware.com>

