

# ASSEMBLY INSTRUCTION

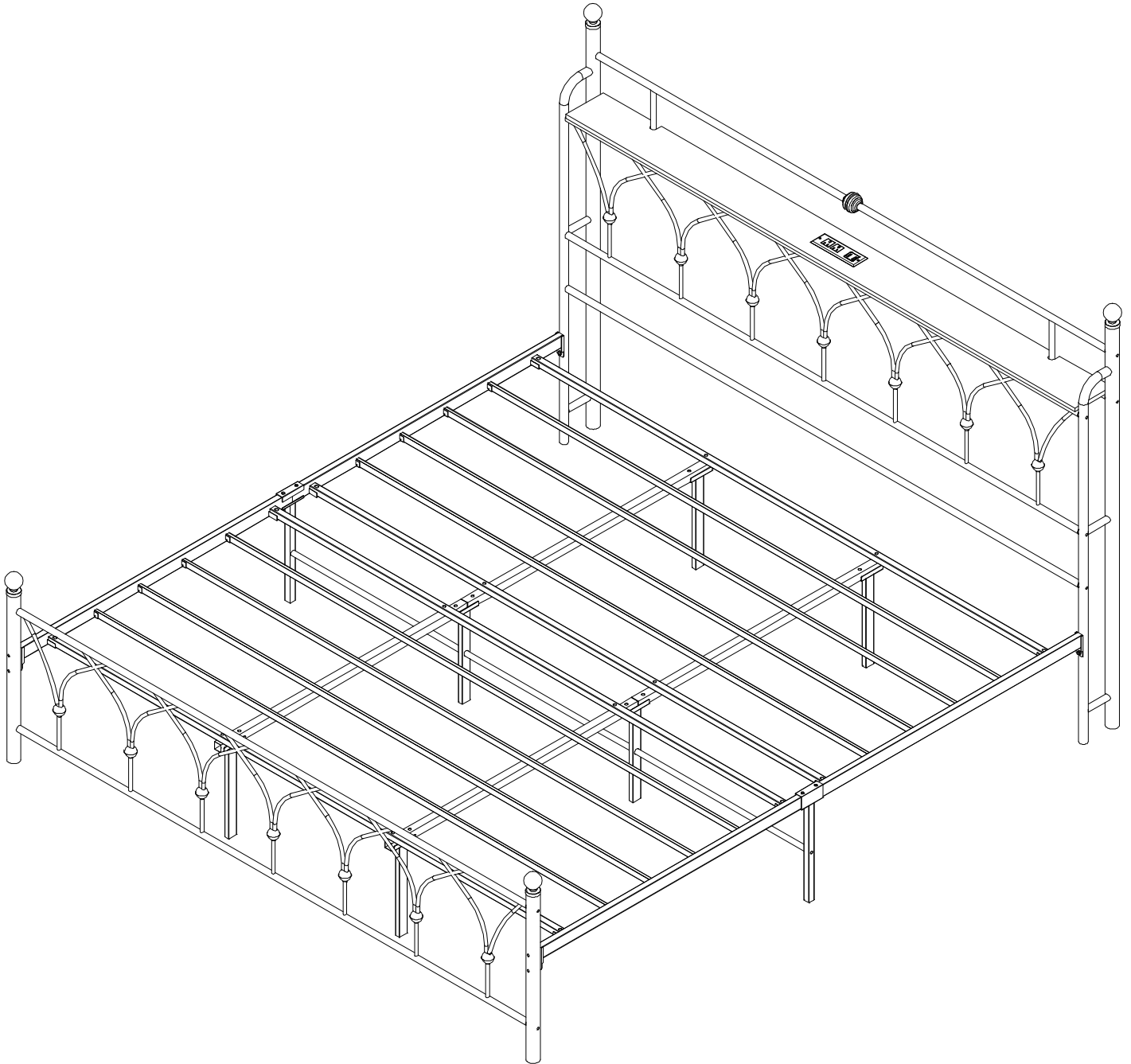



# WARNING

Need Two Or More People To Complete

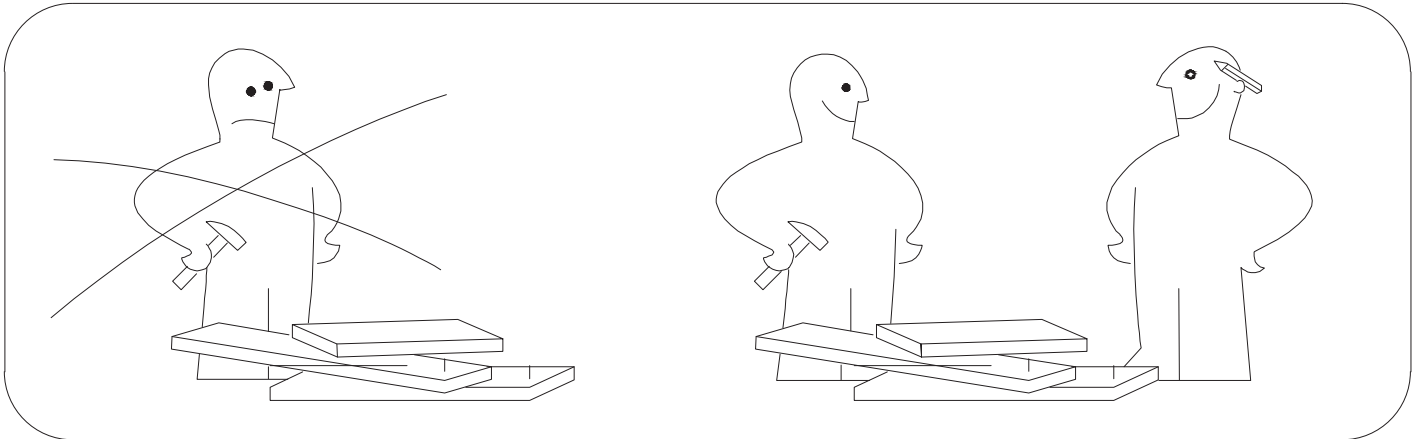

Assemble Item On a Clean Flat Surface

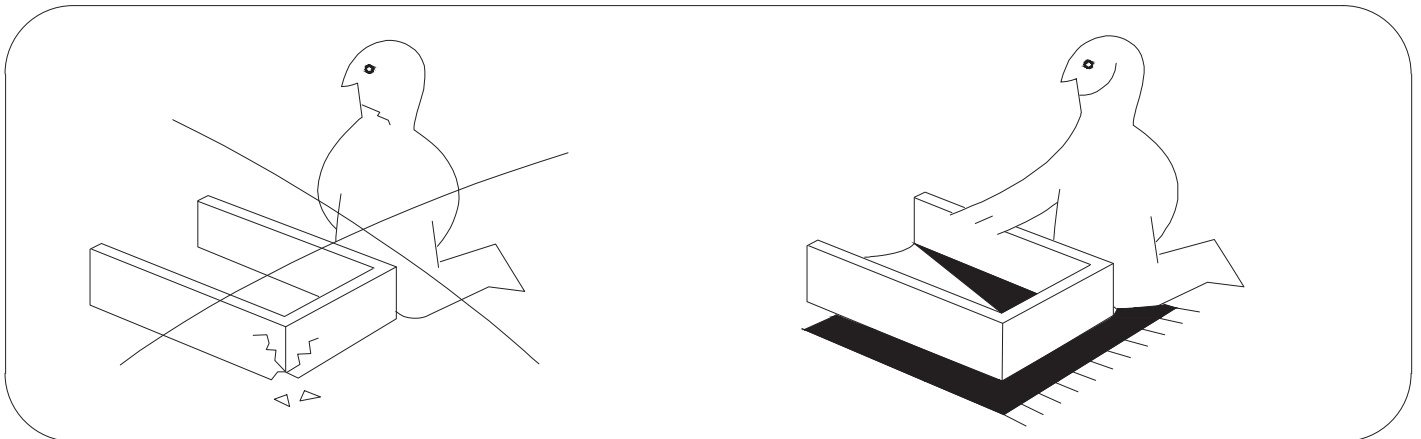

- Please check you have all hardware before assembling.
- Please ensure you have the name of the item and hardware part required and quantity.
- If you have any questions, please contact us by original purchase platform. we will reply you ASAP.
- Please don't tighten the screws completely and go back later for a final tightening of all the screws after pieces are aligned with each other.

# EXPLODED DRAWING:

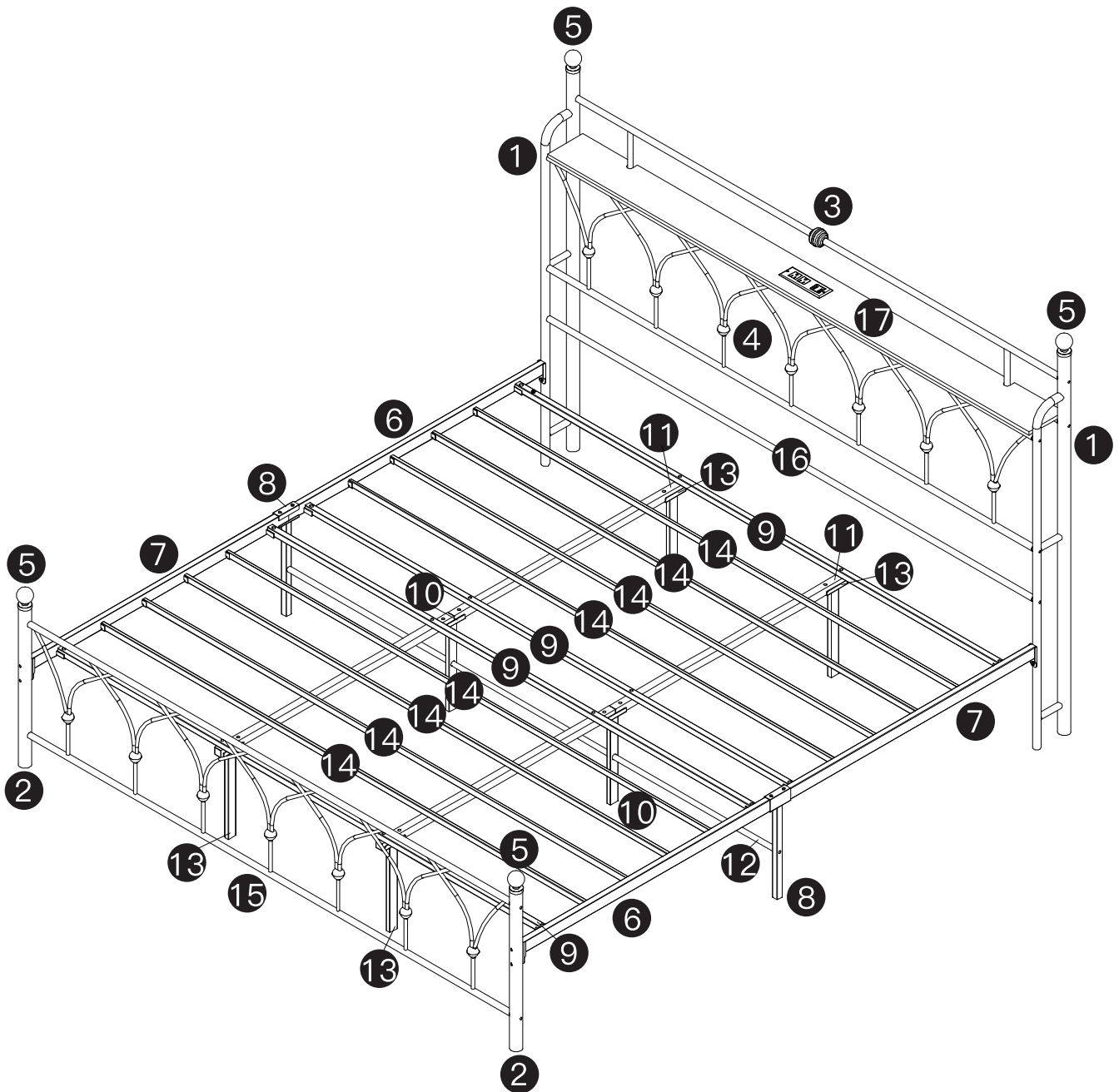

Please check all parts and accessories according to the parts list before assembling, make sure all contents are sufficient and in good condition.

If there is any parts missing or defective, please contact us with purchase platform message immediately to get replacement parts.

## PARTS:

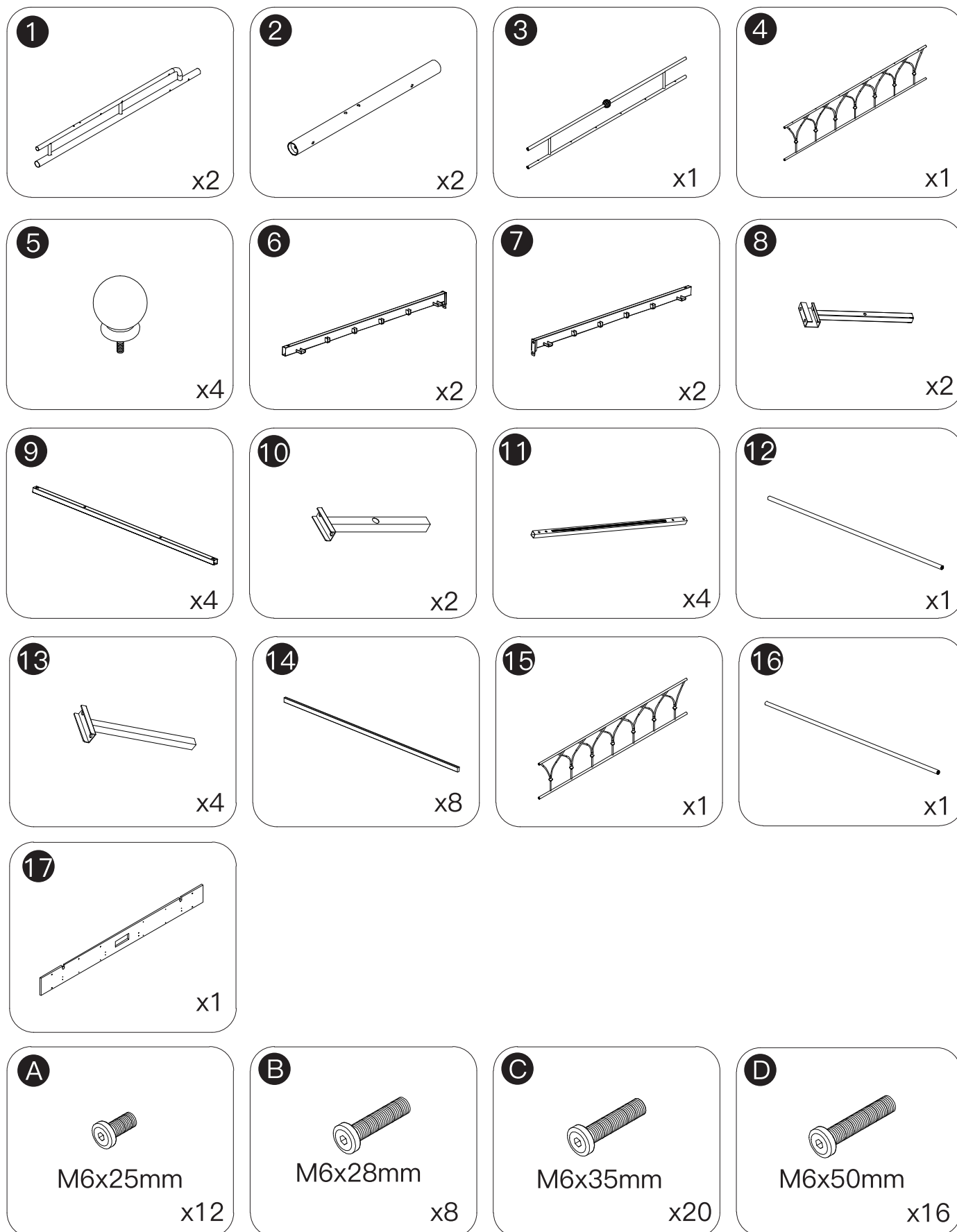

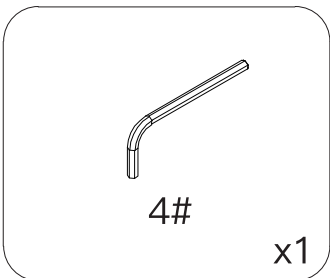
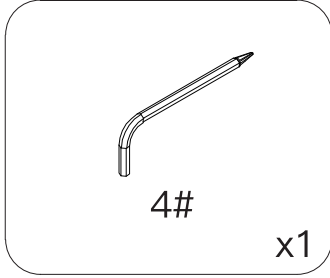
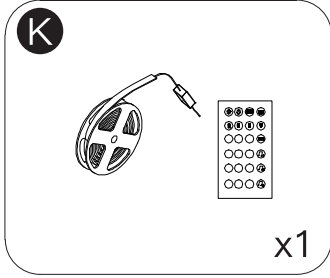
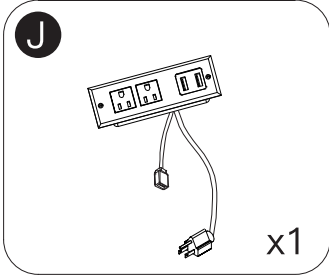
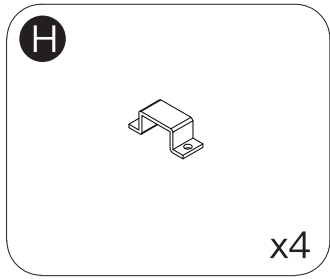
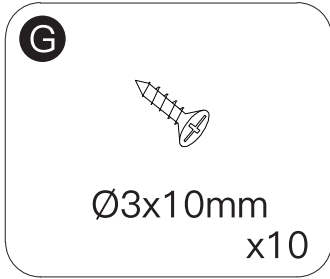
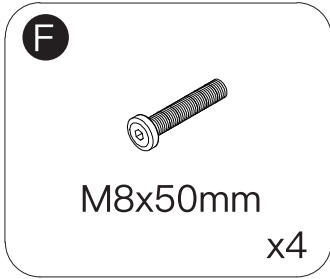
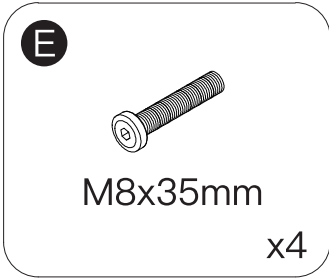

# HOW TO INSTALL

## STEP 1

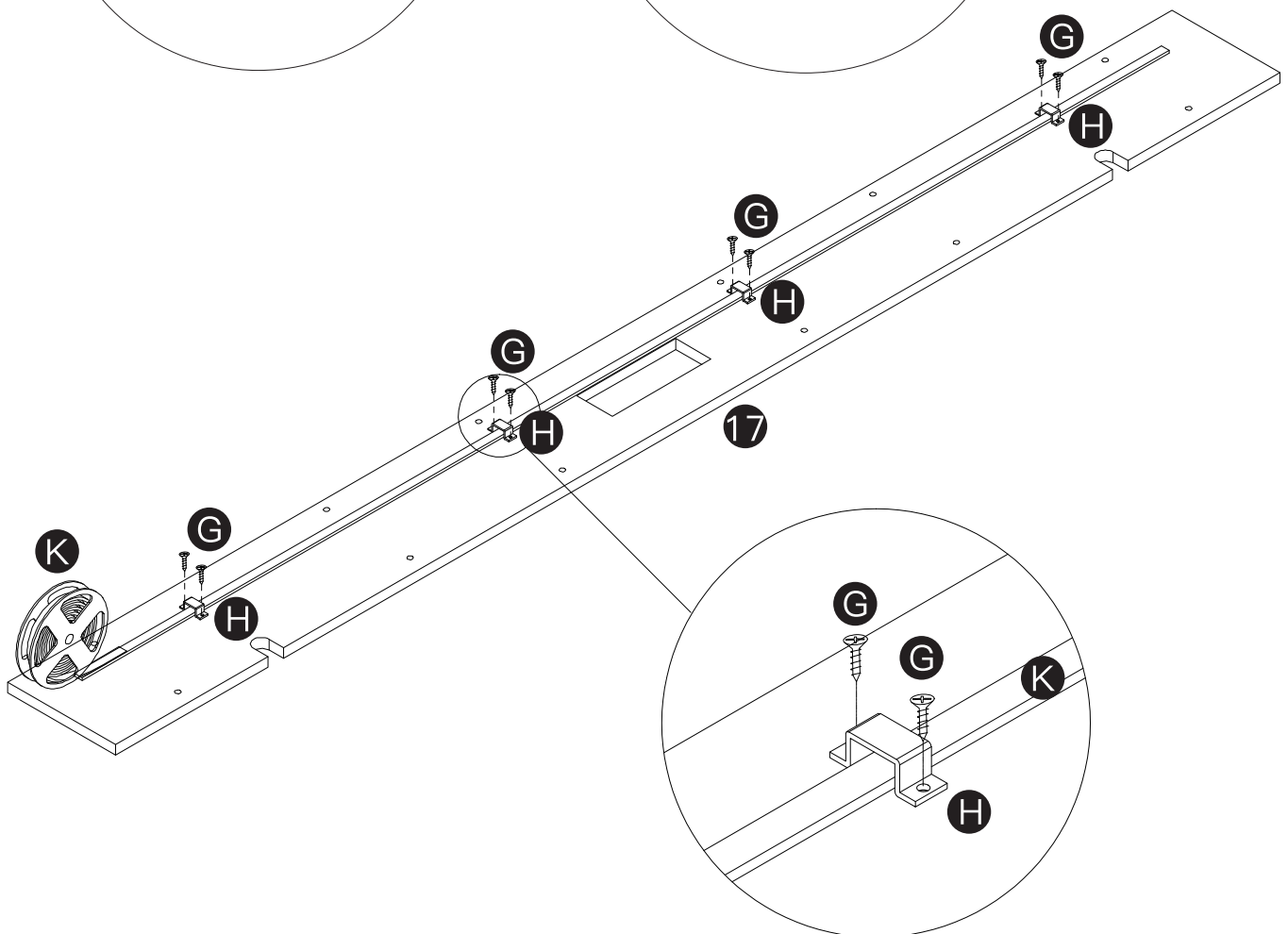
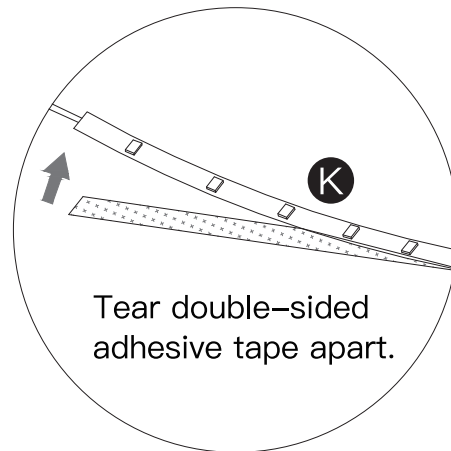
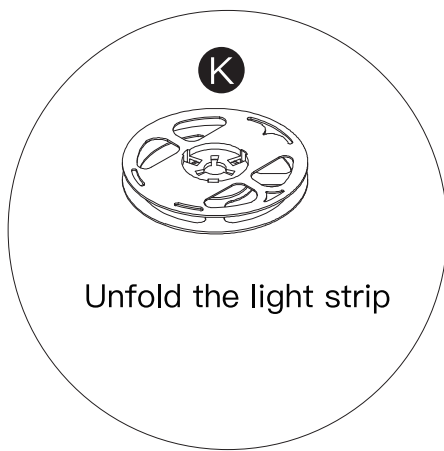
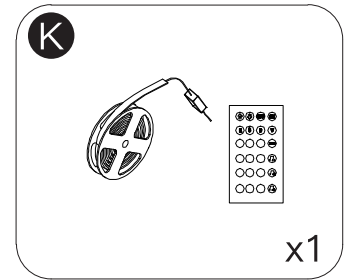
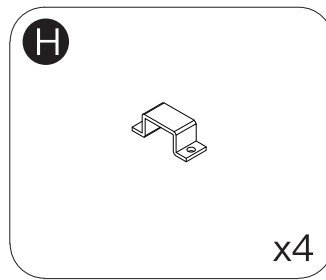
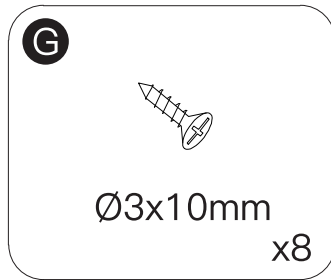
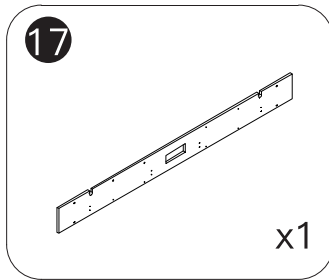

# STEP 2

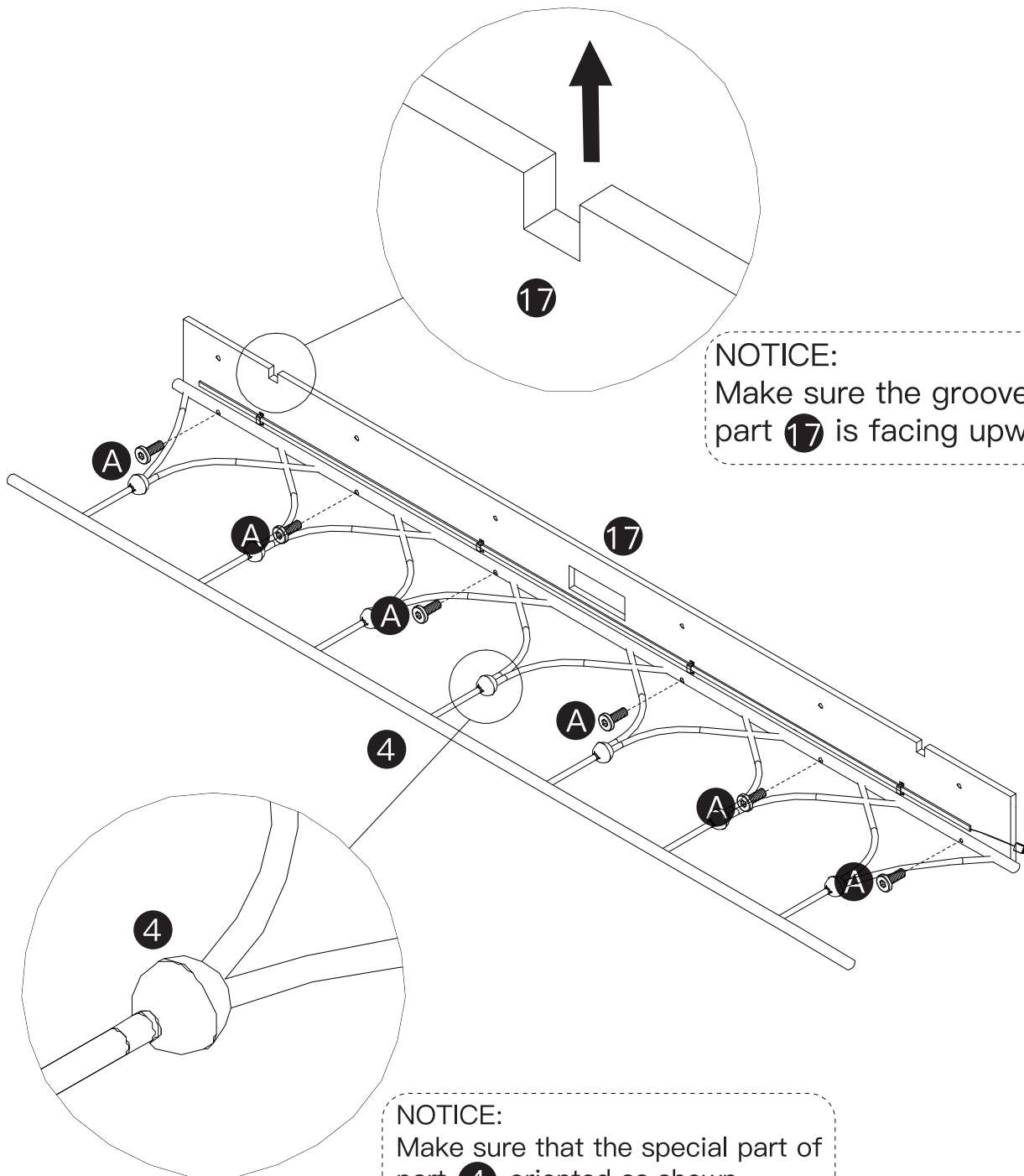
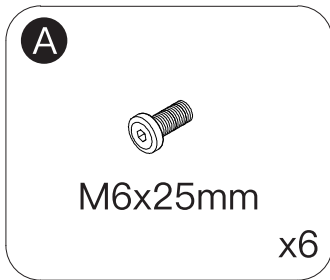
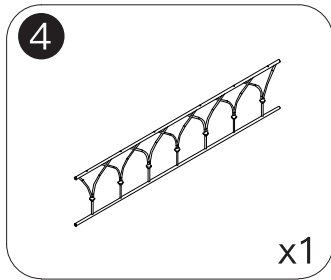

NOTICE:  
Make sure the groove of part 17 is facing upwards.

NOTICE:  
Make sure that the special part of part 4 is oriented as shown.

# STEP 3

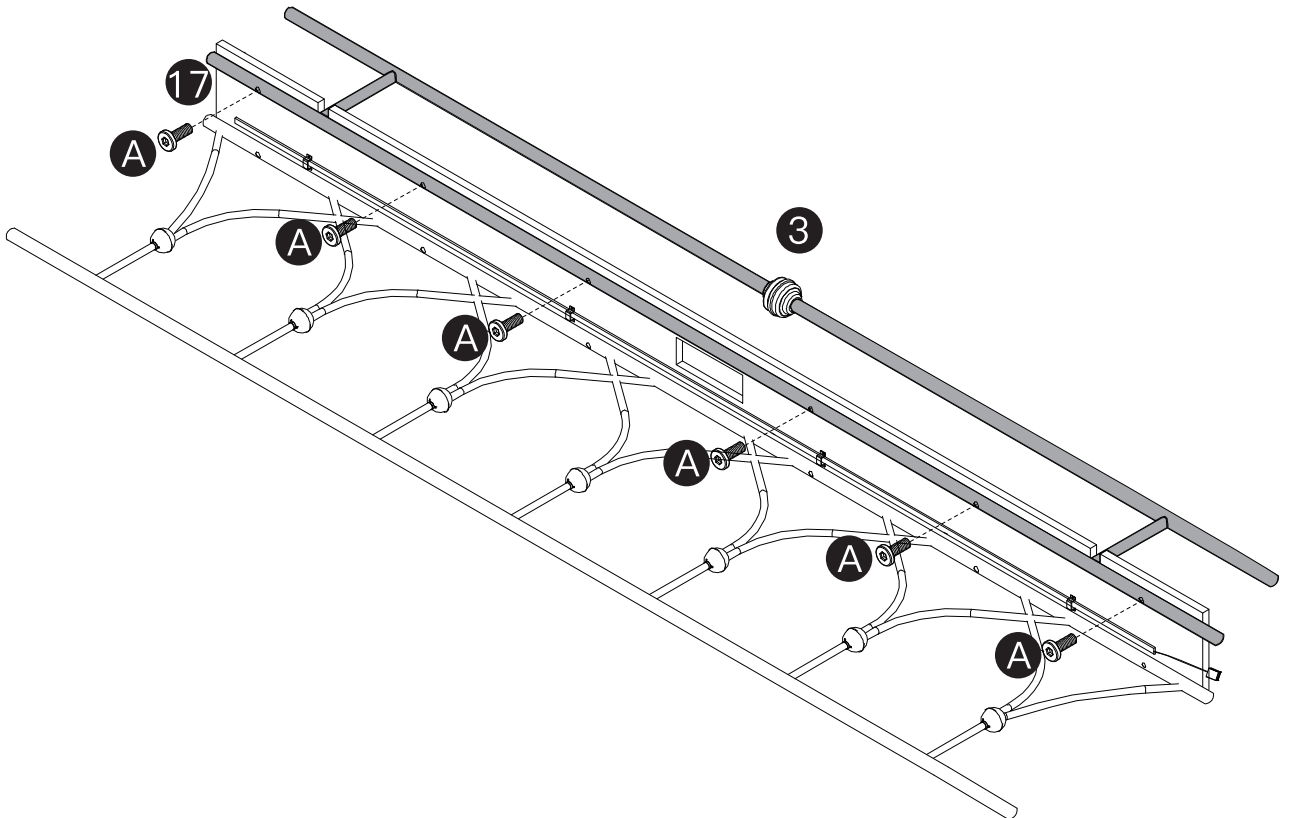
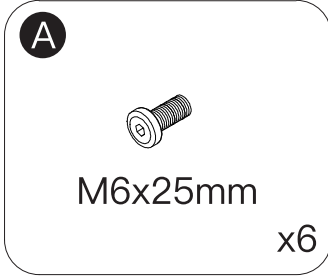
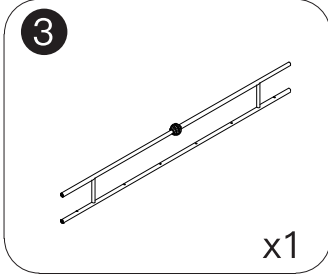

# STEP 4

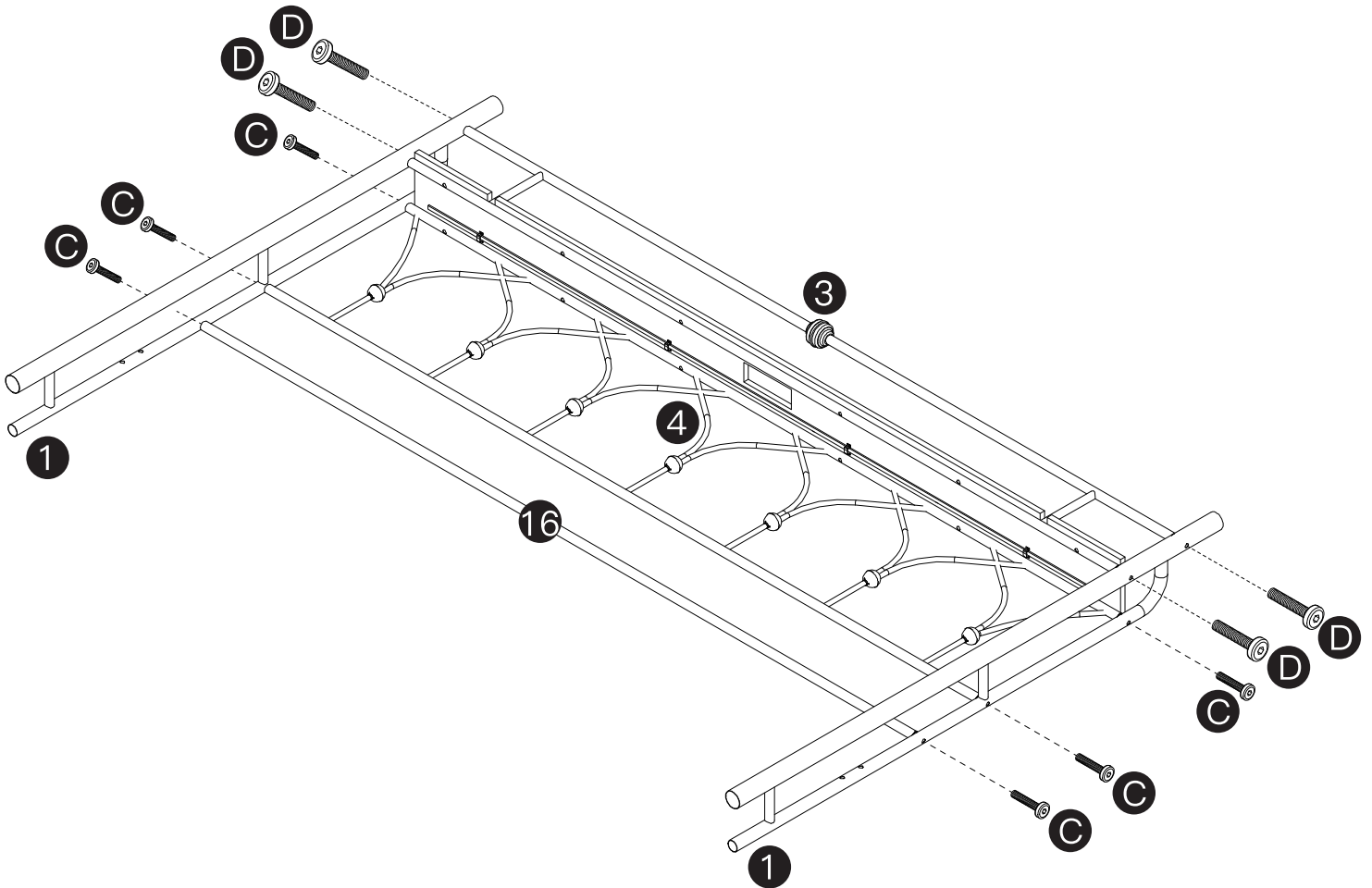
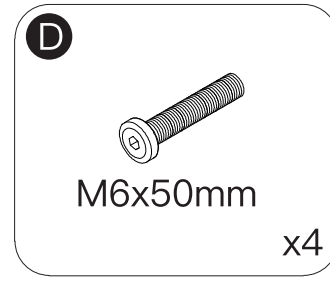
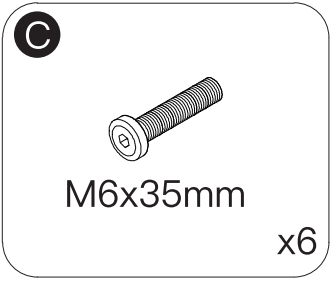
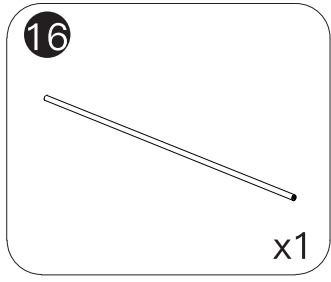
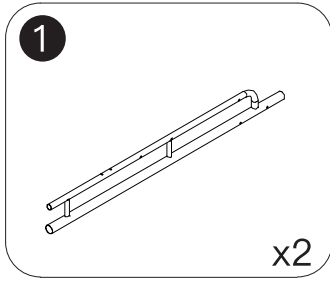

# STEP 5

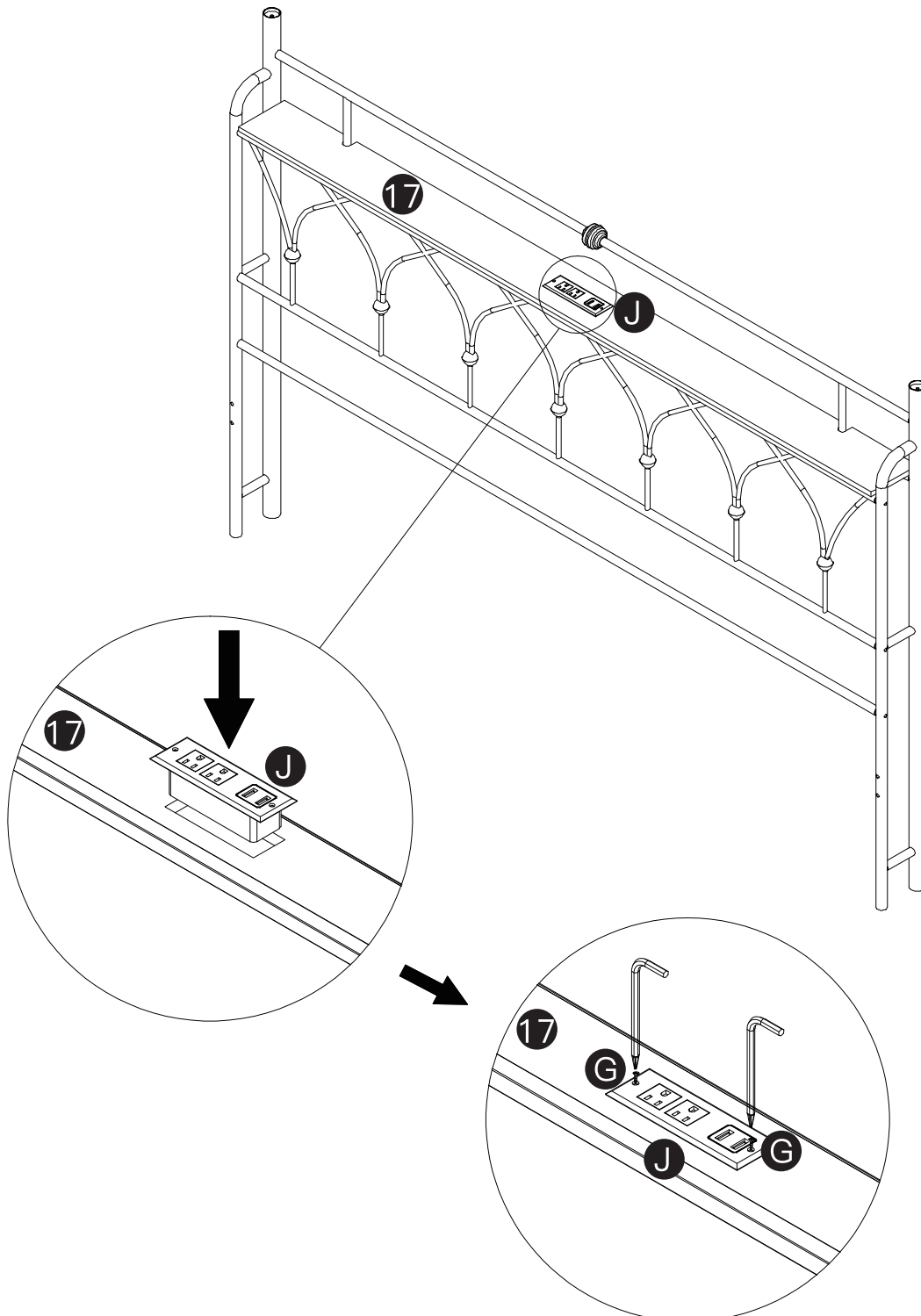
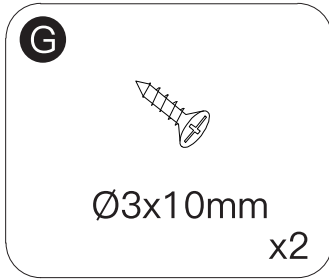
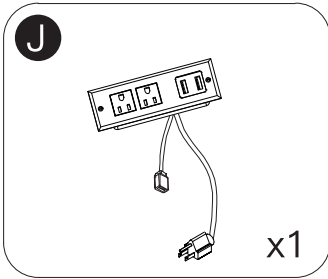

# STEP 6

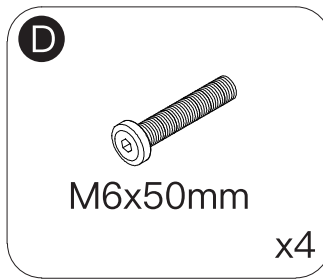
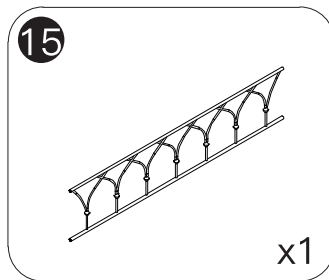
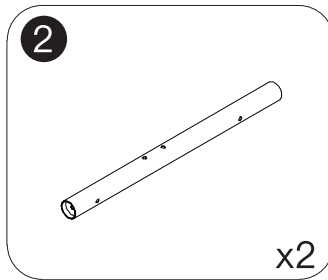

FRONT  
BACK

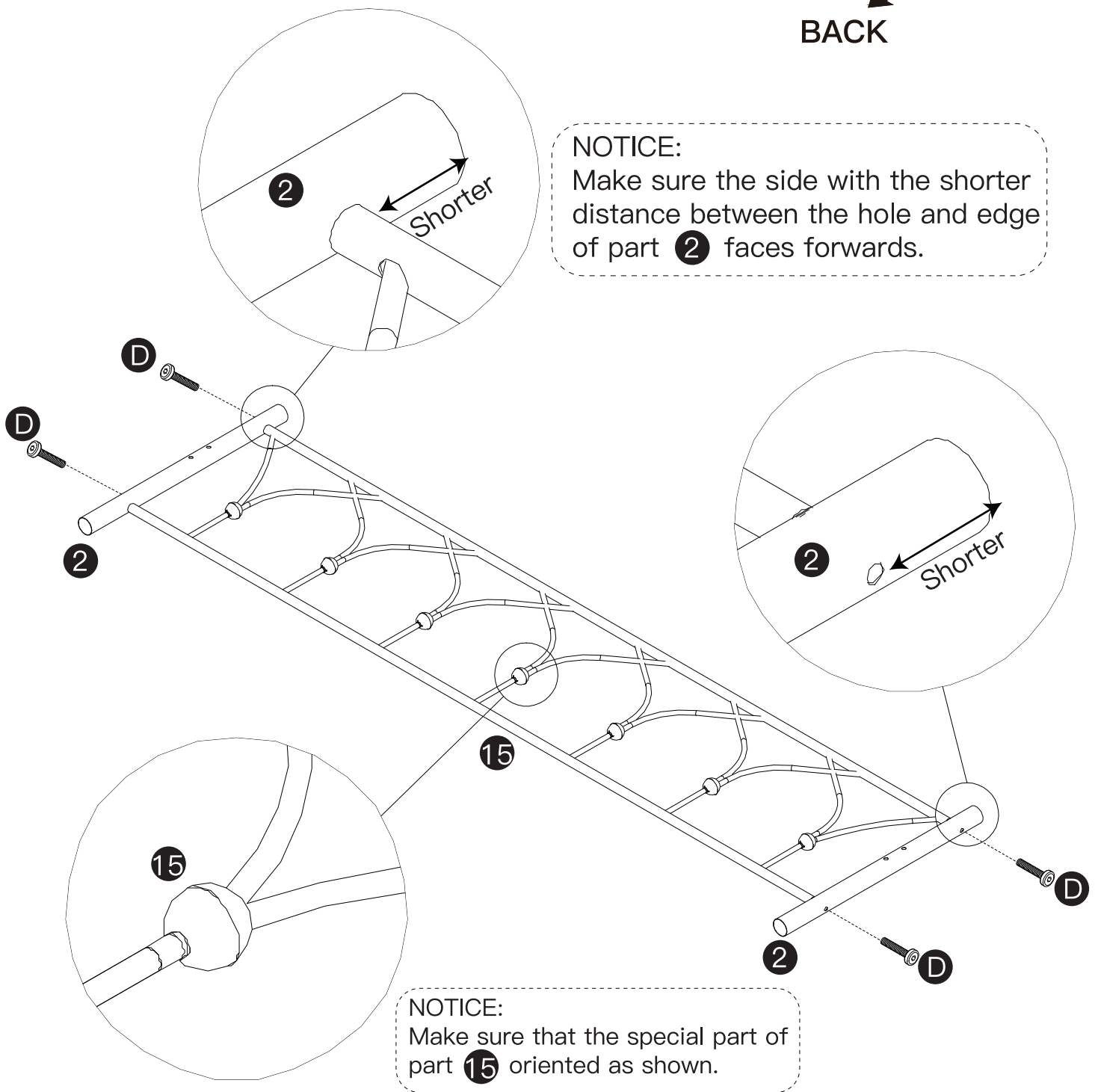

NOTICE:  
Make sure the side with the shorter distance between the hole and edge of part 2 faces forwards.

NOTICE:  
Make sure that the special part of part 15 oriented as shown.

# STEP 7

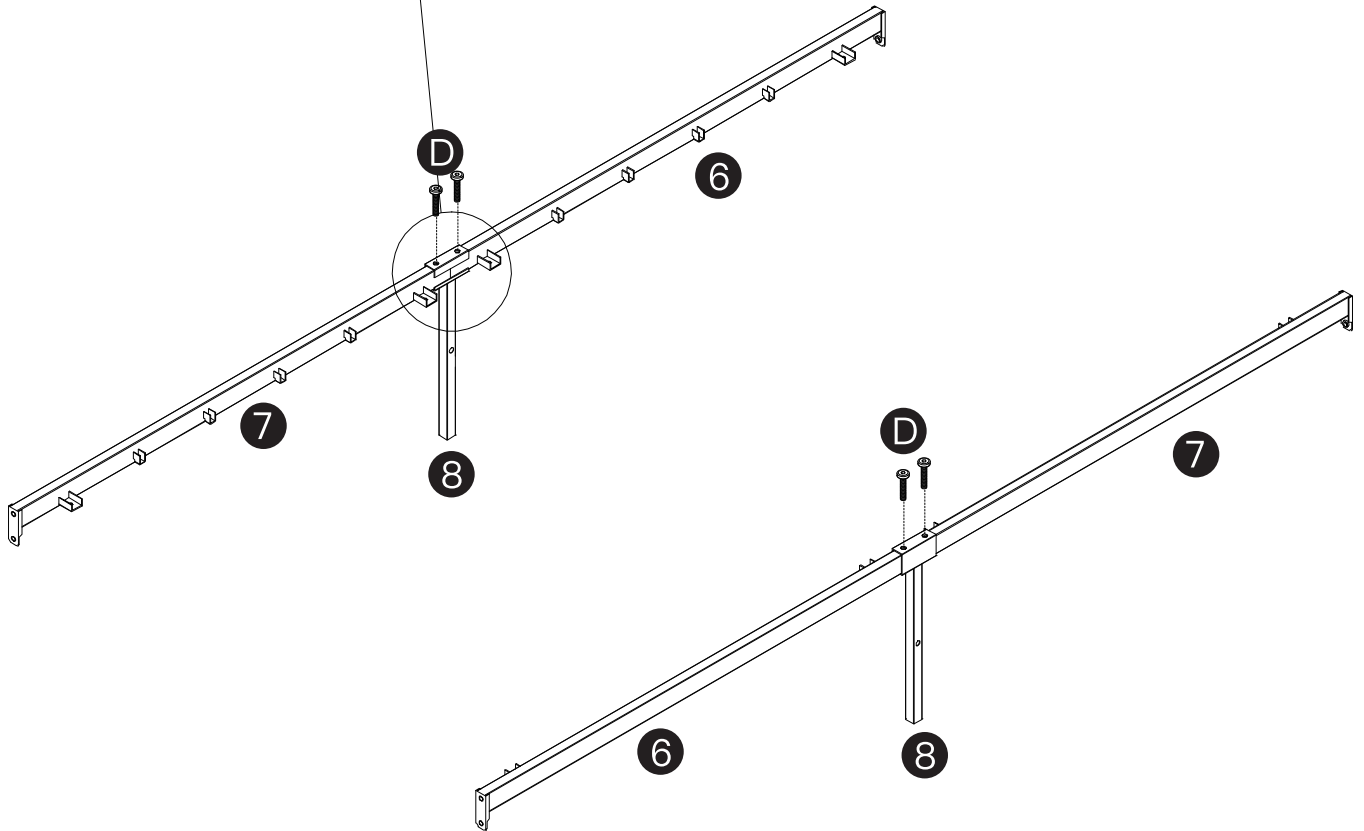
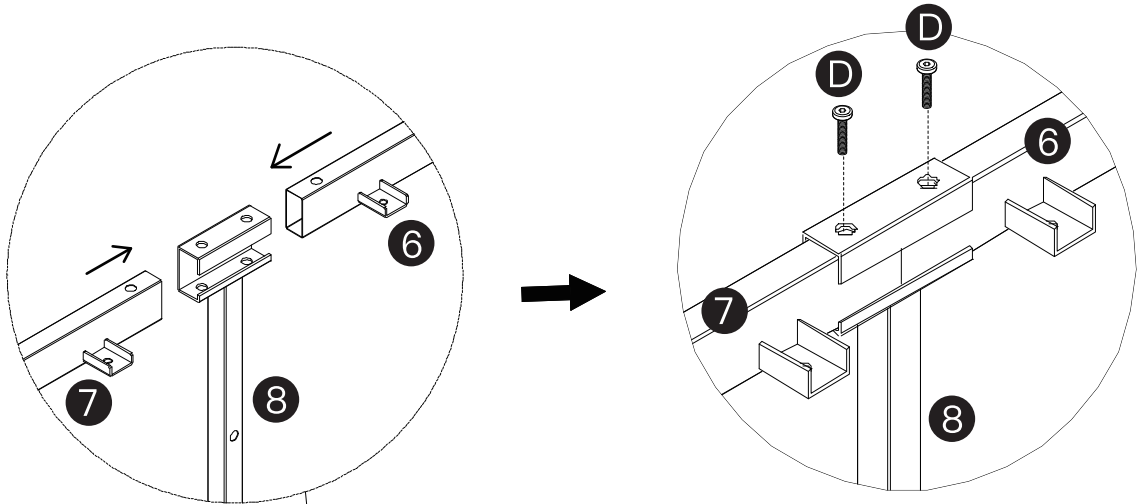
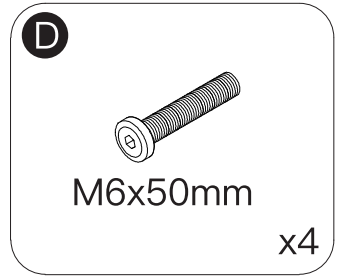
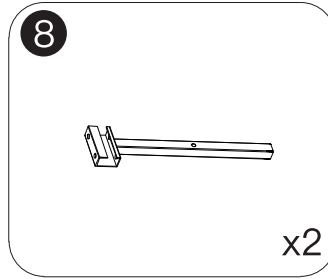
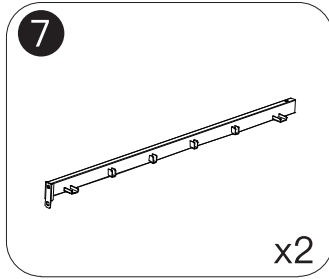
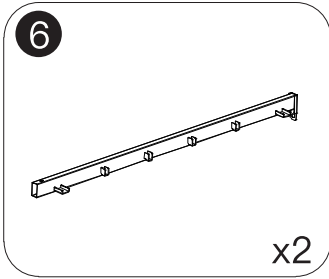

# STEP 8

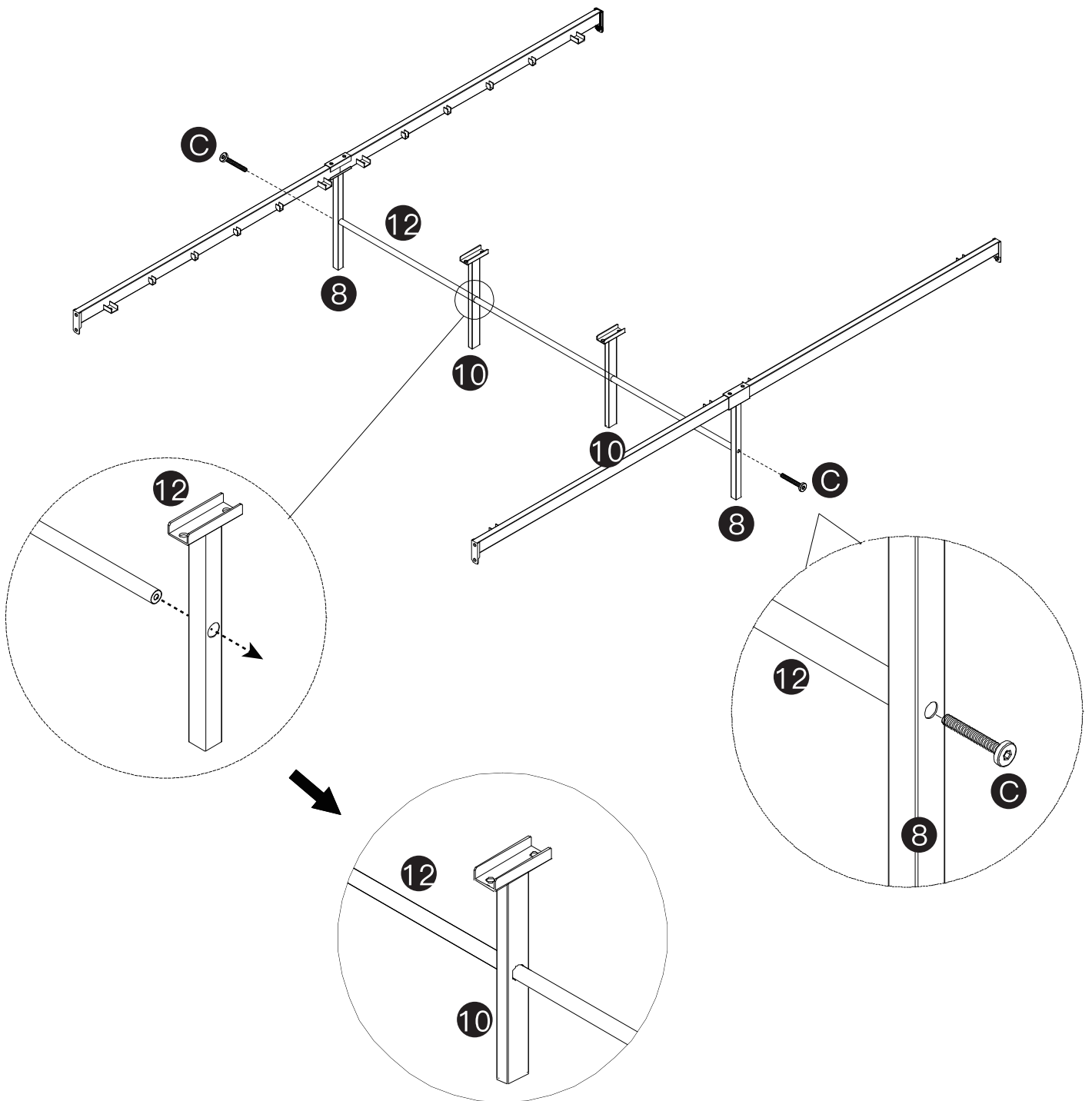
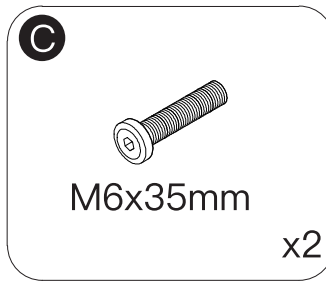
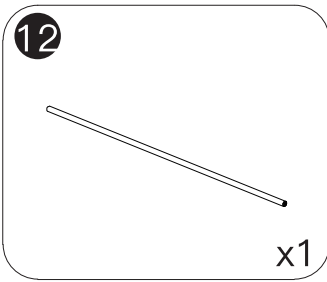
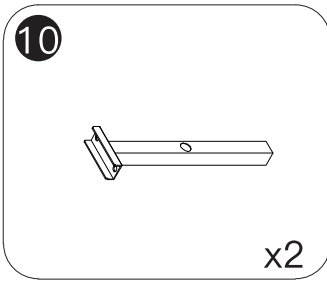

# STEP 9

**E**

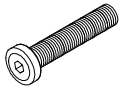

M8x35mm

x4

**F**

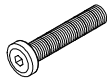

M8x50mm

x4

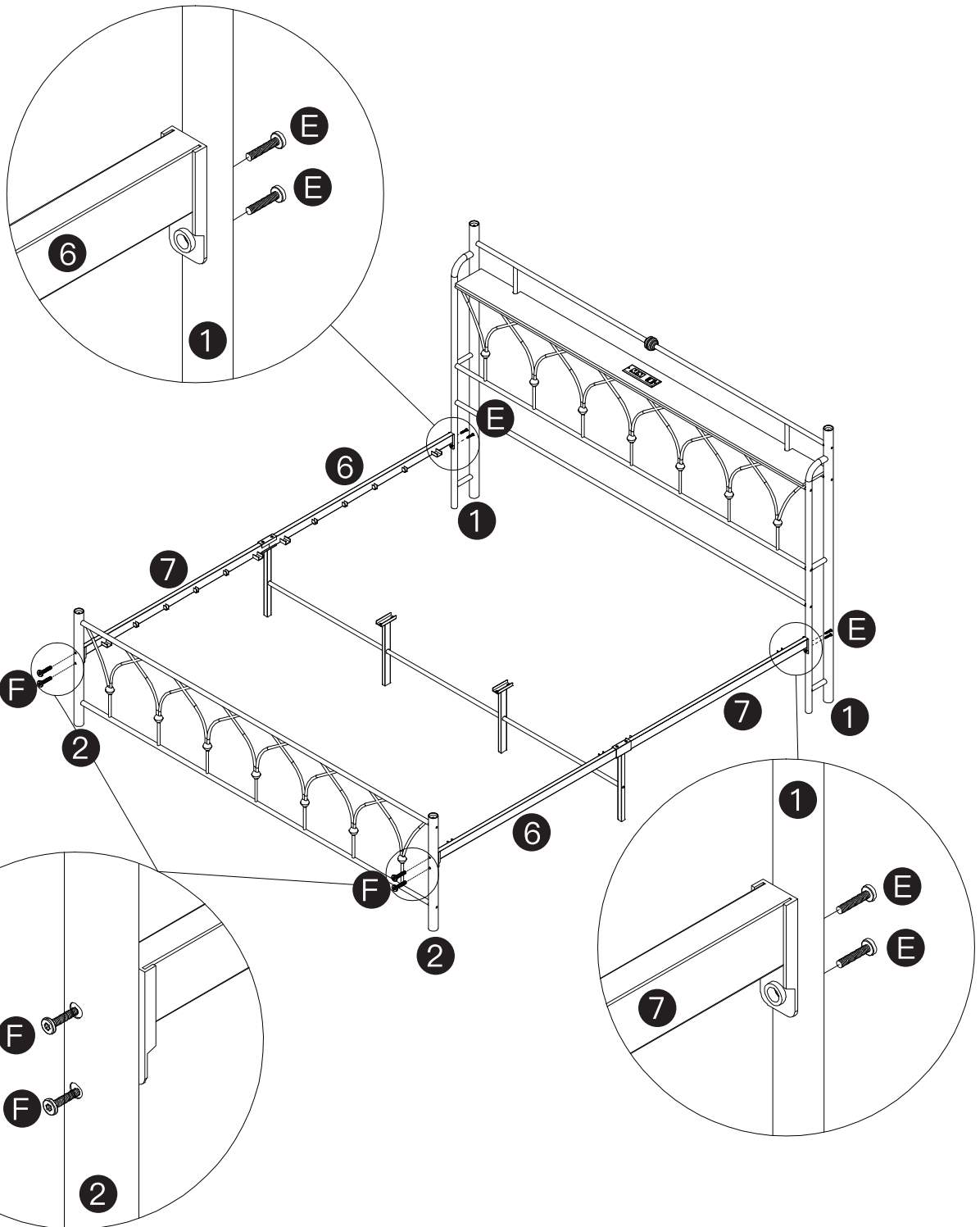

# STEP 10

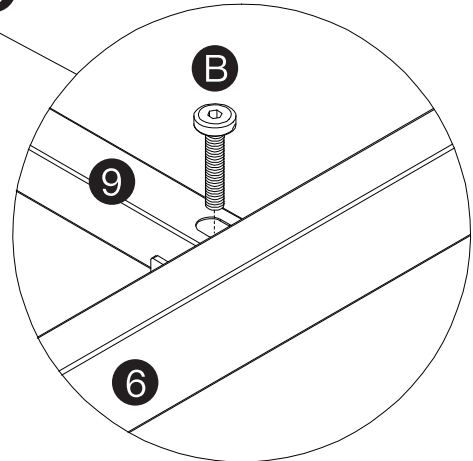
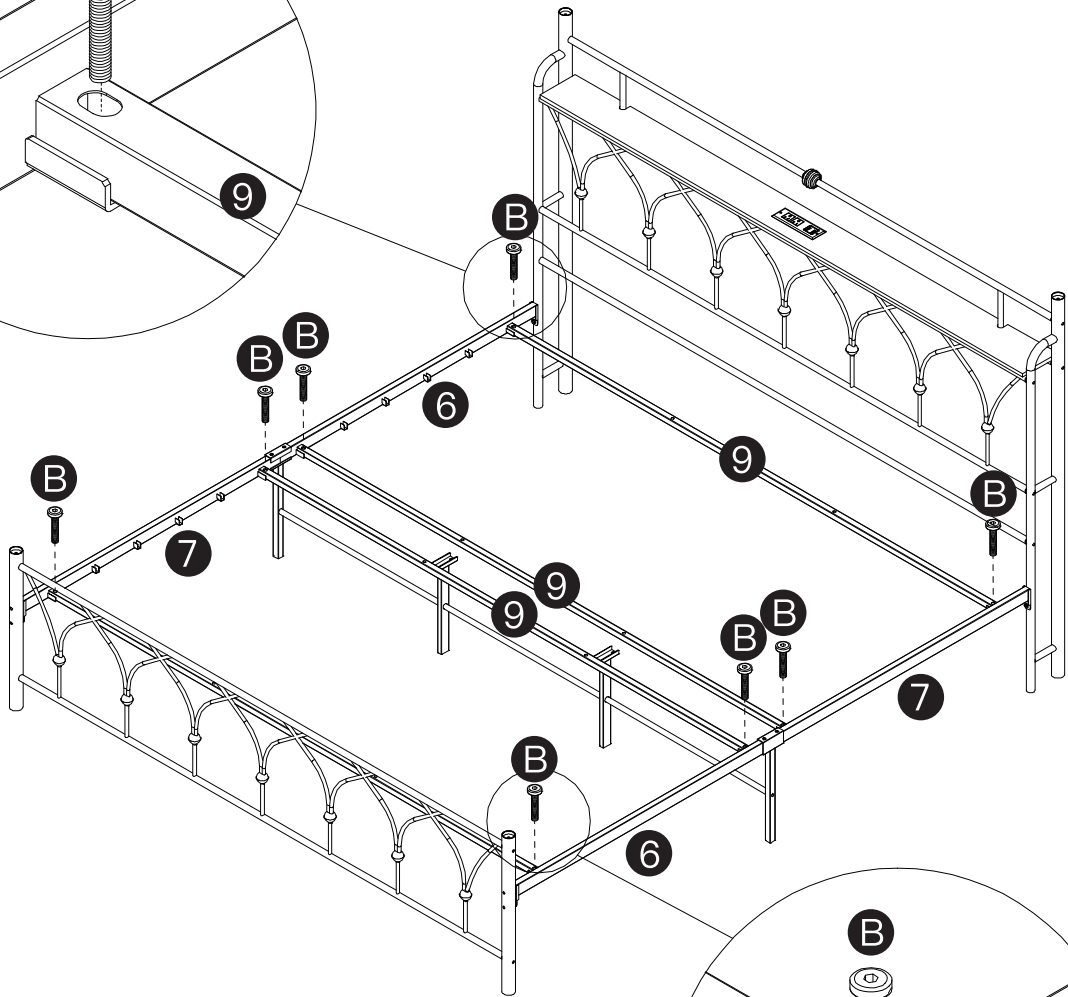
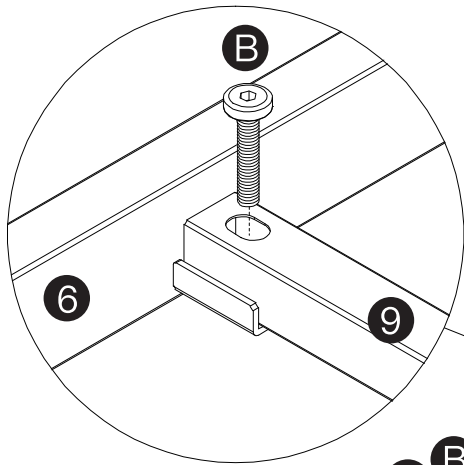
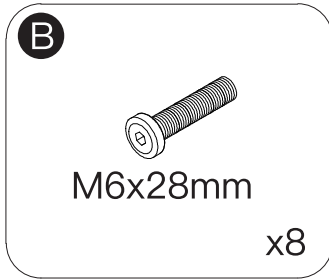
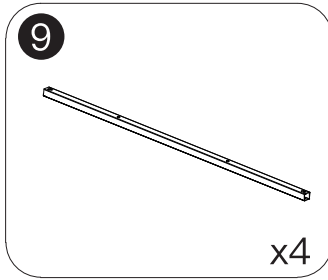

# STEP 11

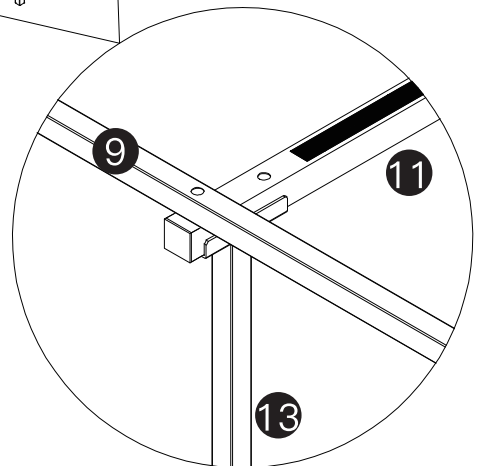
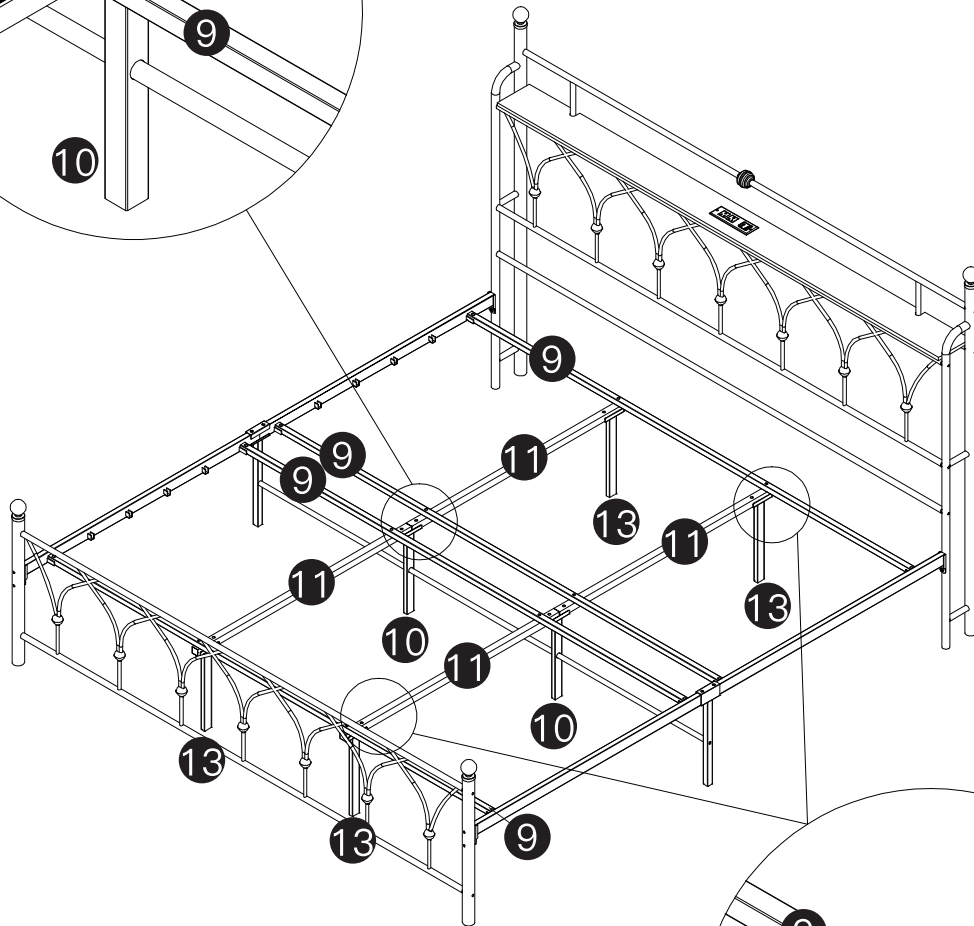
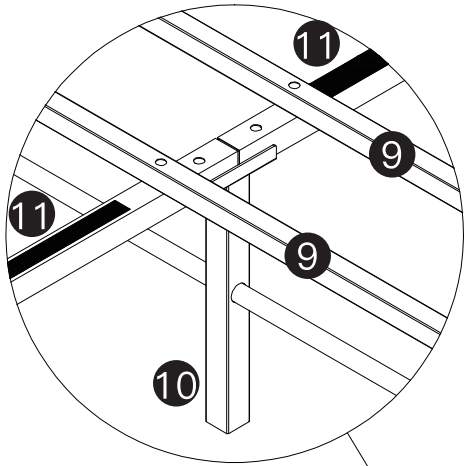
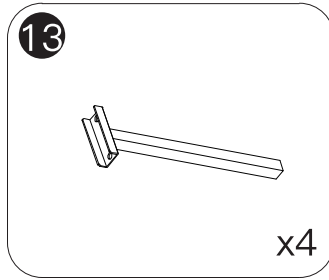
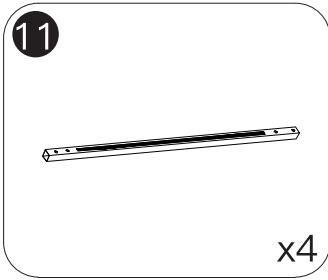

**NOTICE:**

Make sure part **11** with plastic rectangular ribbed tube on the outside.

# STEP 12

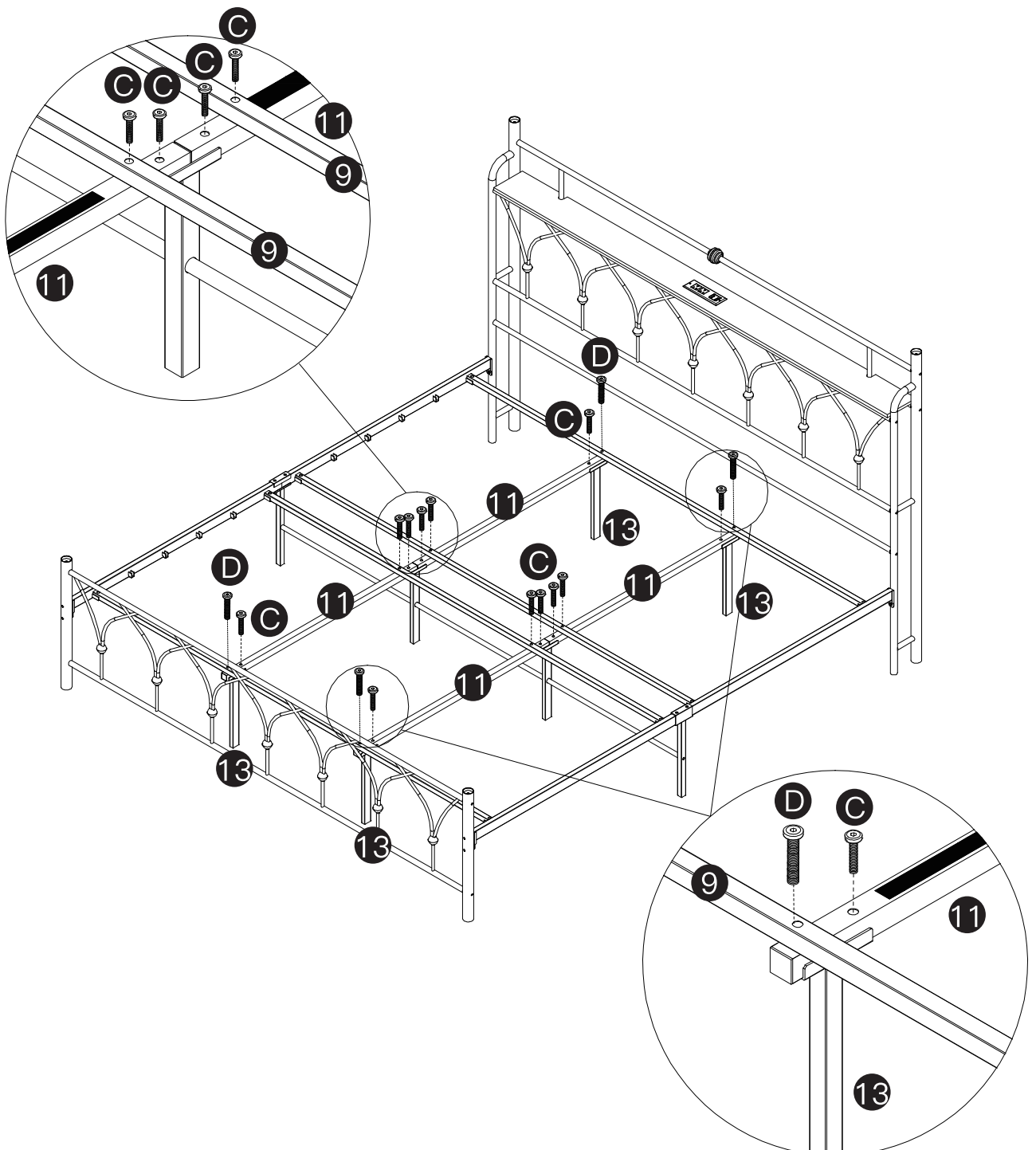
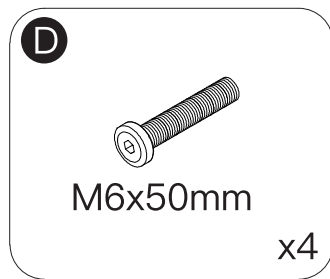
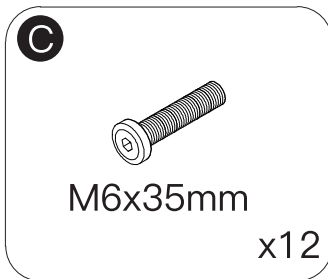

# STEP 13

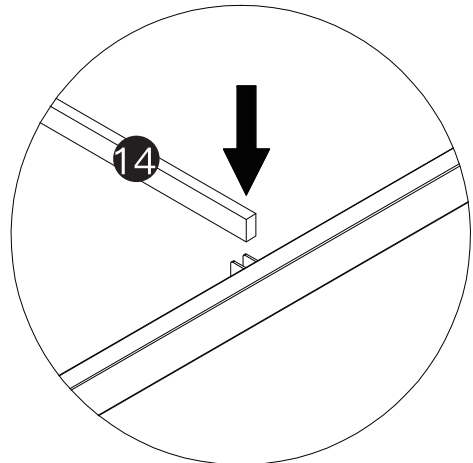
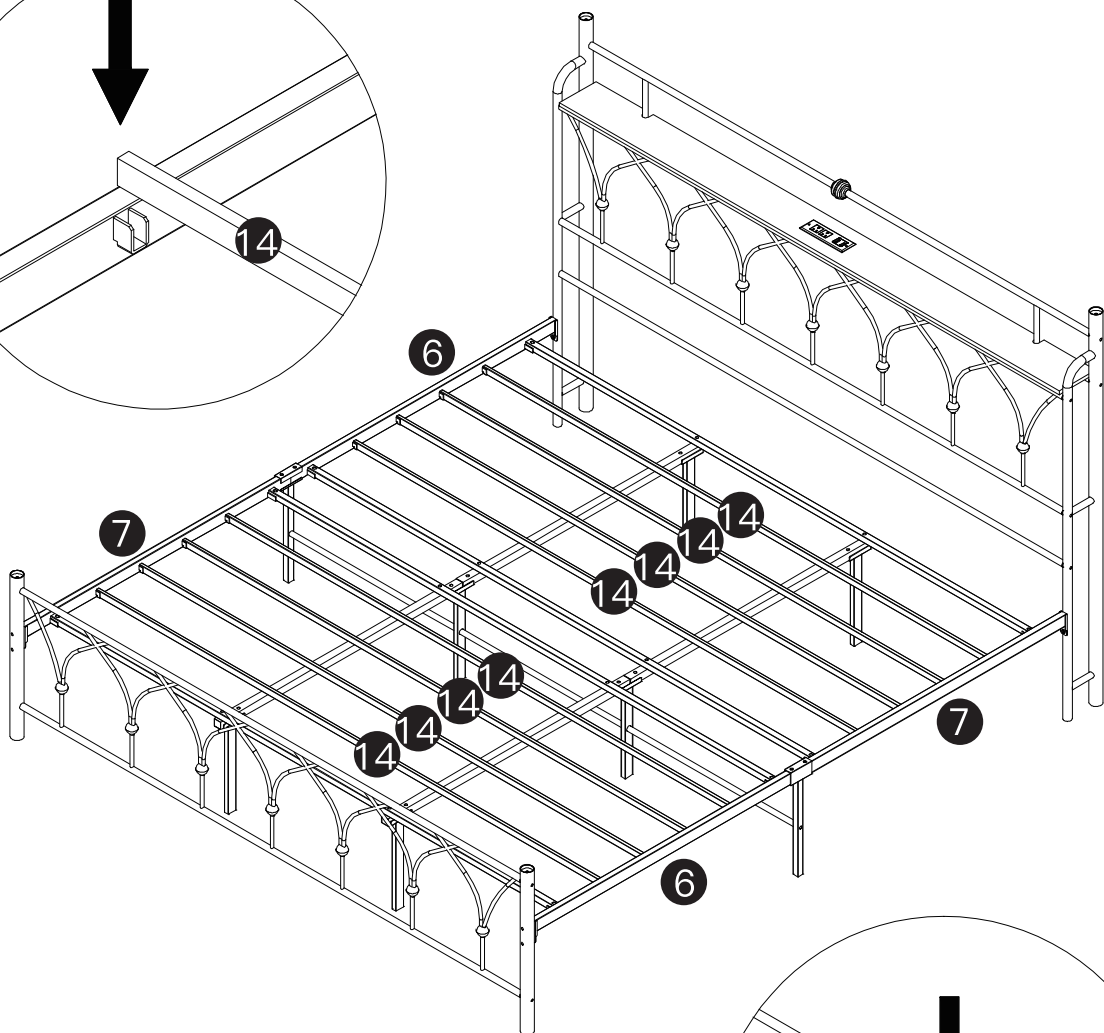
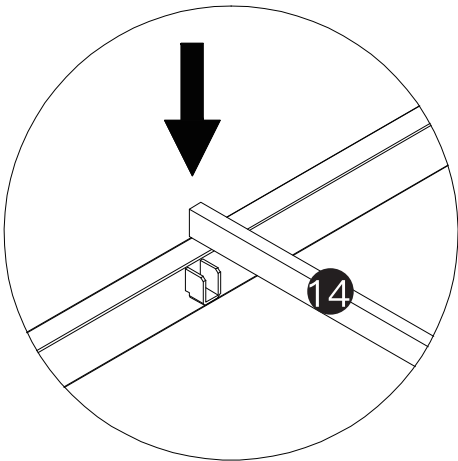
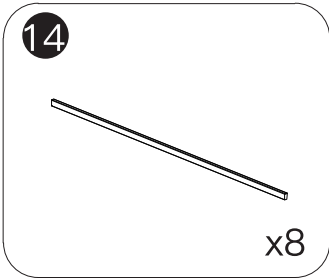

# STEP 14

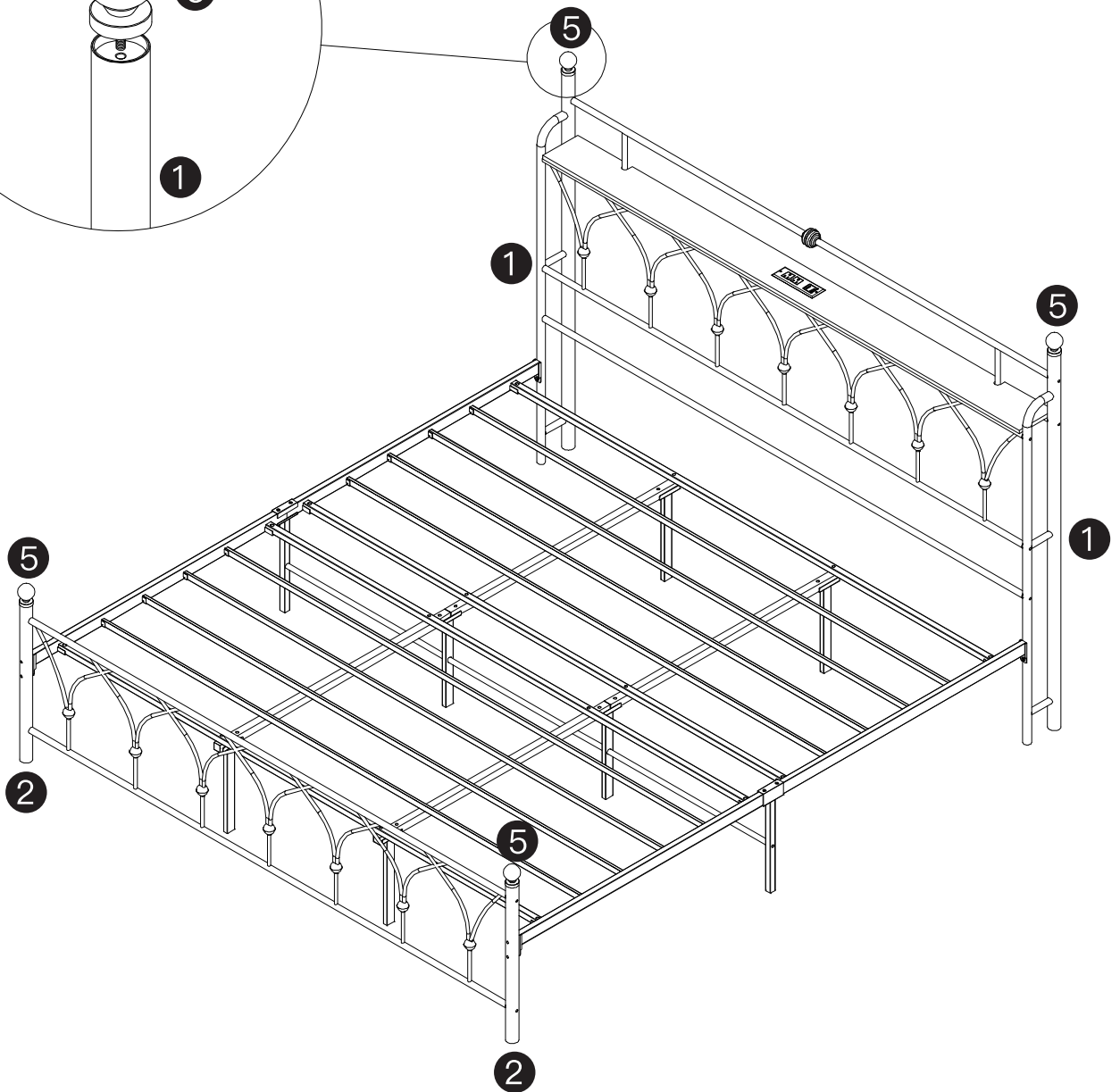
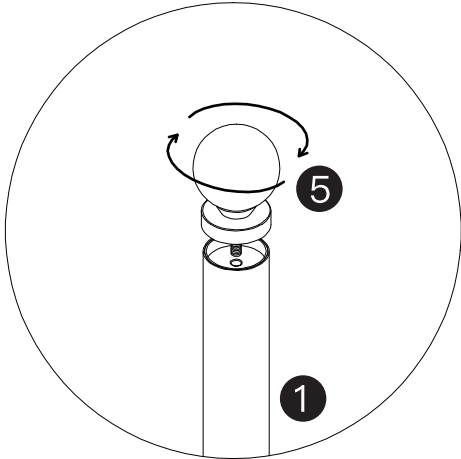
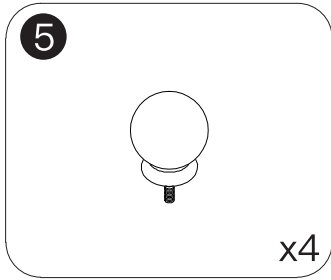

## AFTERSALE SERVICE

Dear customer,

Thank you so much for purchasing the product from us, we really appreciate your support.

We are aimed to provide the best shopping experience to our customers. We also want to build a mutually beneficial relationship with our customers, and step further to make our brand both reliable, responsible and recommendable.

We hope that our products could meet your needs and expectations, please consider us again if you need more products for your home and kitchen.

The package would be out of our control during shipping, please contact us through your purchasing channel directly if there is anything wrong with the box or contents. We are always here offering you our service.

We will reply your messages within 24 hours, please kindly wait for the response from our professional service team.

Your comfort and contentment are of utmost importance.

Best Regards,

Customer Care Specialist