

Transforming houses into homes (English & Español)

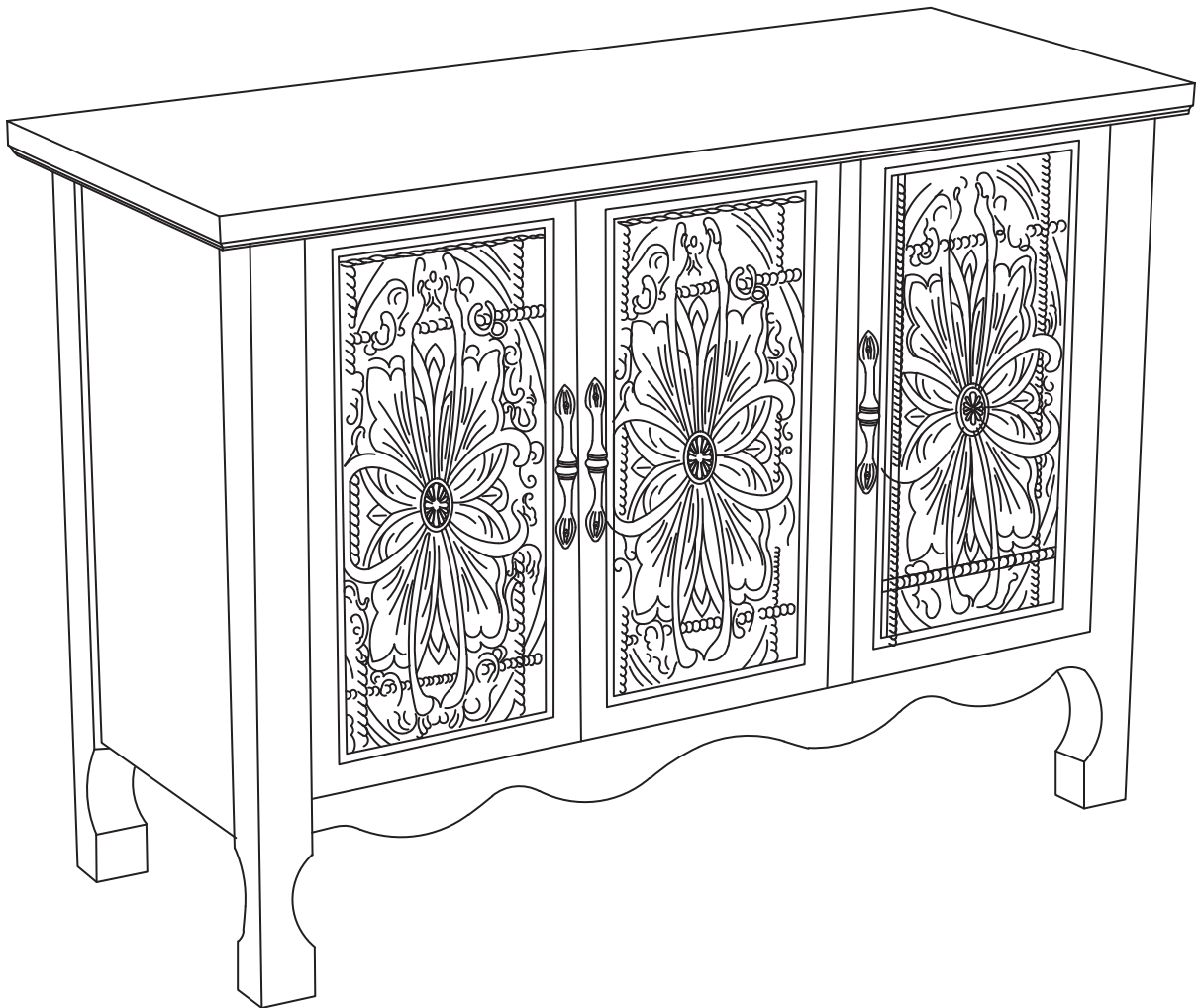

INSTRUCTION MANUAL

If you have any problems, please send your order number and photos to us
We will contact you within 24 hours and provide you with a satisfactory solution.

! NOTICE Please retain these instructions for future reference.

- Carefully unpack all the components and verify that all the necessary parts are included as listed in the packaging.
- Identify each component and refer to the provided assembly diagram or step-by-step instructions.
- Assemble the furniture in the order specified to ensure proper alignment and fit.
- Use the provided tools or recommended tools for assembly. Do not use excessive force when tightening screws or bolts.
- If any difficulties arise during assembly. Consult the troubleshooting section or contact our customer support.

 ASSEMBLY INSTRUCTIONS

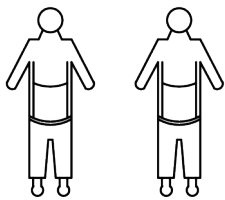

2 people

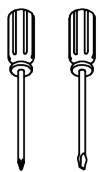

Phillips Screwdriver

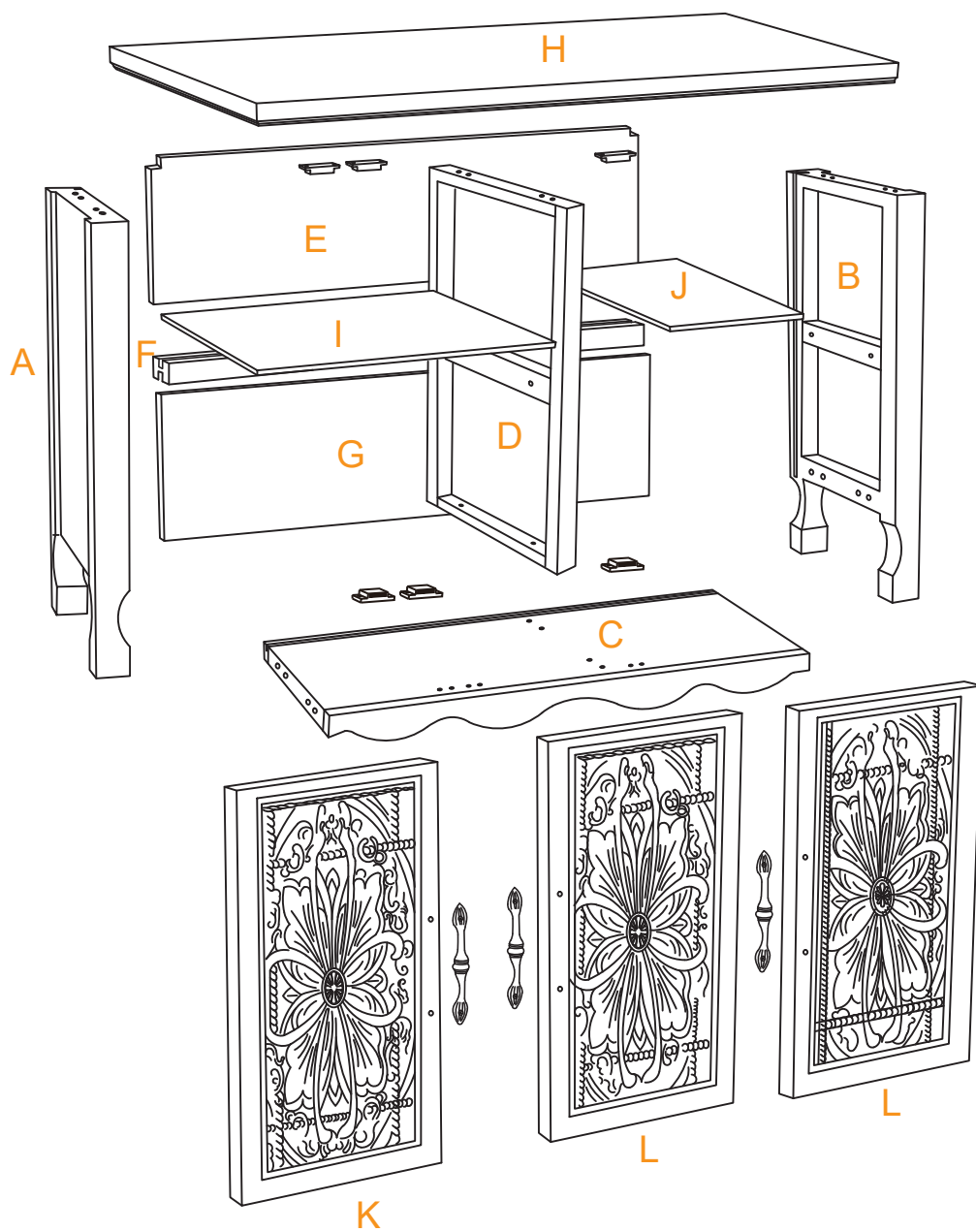

☰ PARTS LIST

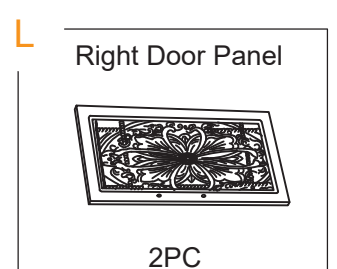
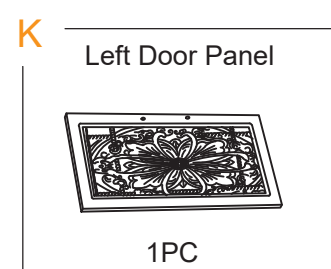
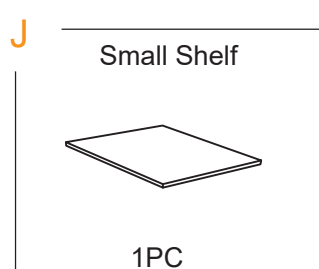
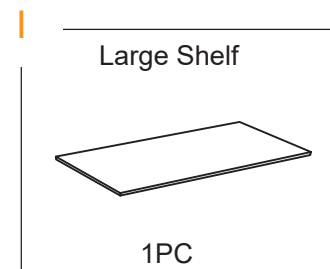
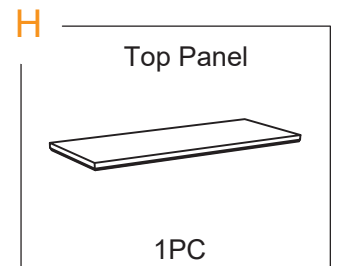
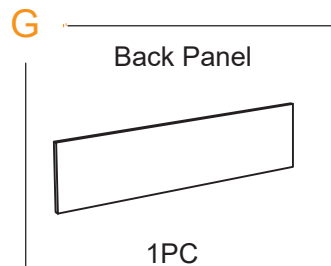
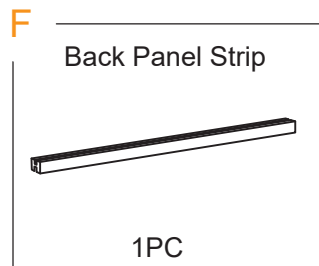
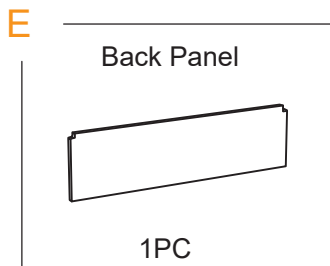
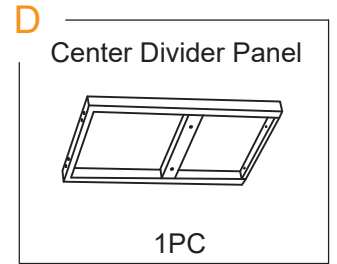
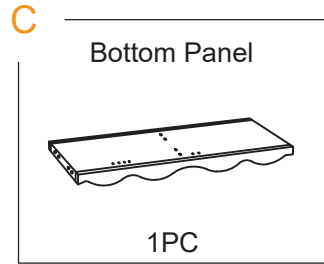
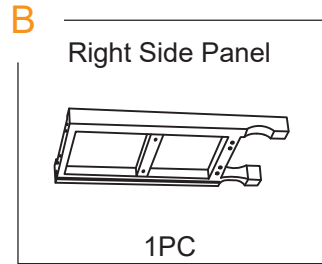
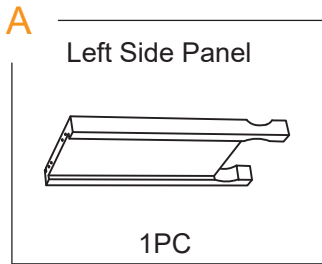

☰ HARDWARE LIST

01

Ø8x40mm
Bolt

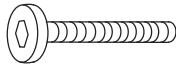

12+1 PCS

02

Washer



12+1 PCS

03

Shelf Support

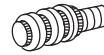

8 PCS

04

Magnetic Catch



6 PCS

05

Ø3x16mm
Screw



48+1PCS

06

Ø3.5x14mm
Screw



6+1 PCS

07

Metal Plate



6 PCS

08

Door Handle



3 PCS

09

Anti-Tip Device

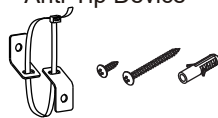

2 PCS

10

Allen Wrench



1 PC

11

Hinge



6 PCS

12

Rear Panel Hook



8 PCS

13

Wood Dowel



12 PCS



If you are missing any parts, please provide your order number and circle the part number. Send us a photo of this, and we will provide you with a satisfactory solution. Thank you.

STEP 1

Please tighten the screws after completing all installation.

Por favor, apriete los tornillos después de instalar todo.

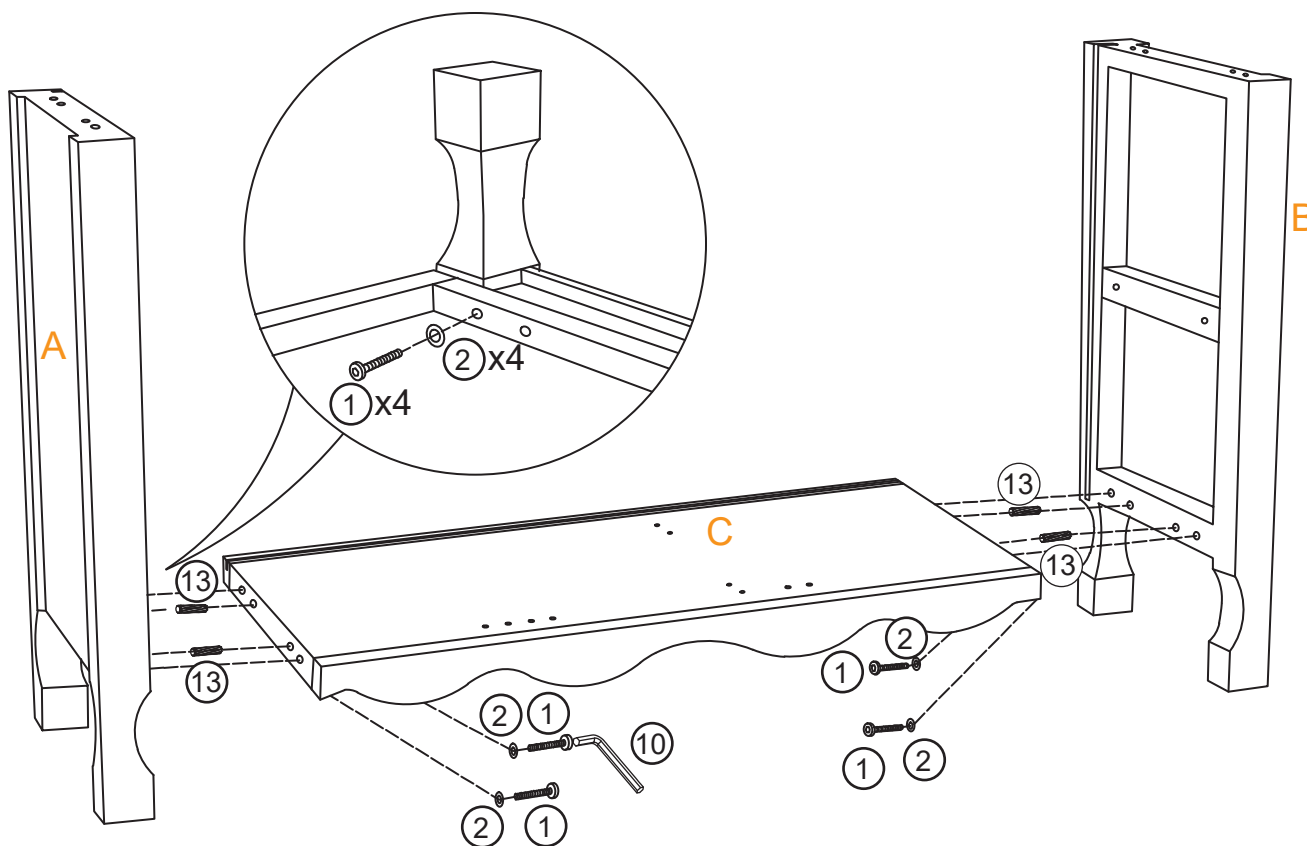
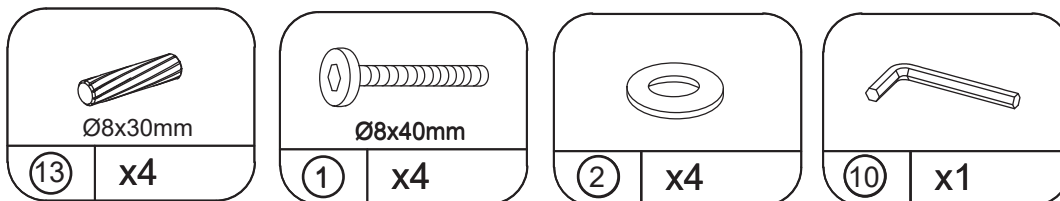

Insert the wood dowel 13 into the panel A and B, place washer 2 onto bolt 1, connect the bottom of side panels A and B to baseboard C, and tighten with a wrench.

⚠ Reminder: Do not fully tighten any screws into threads during assembly. Tighten all screws only after assembly is complete.

STEP 2

Please tighten the screws after completing all installation.

Por favor, apriete los tornillos después de instalar todo.

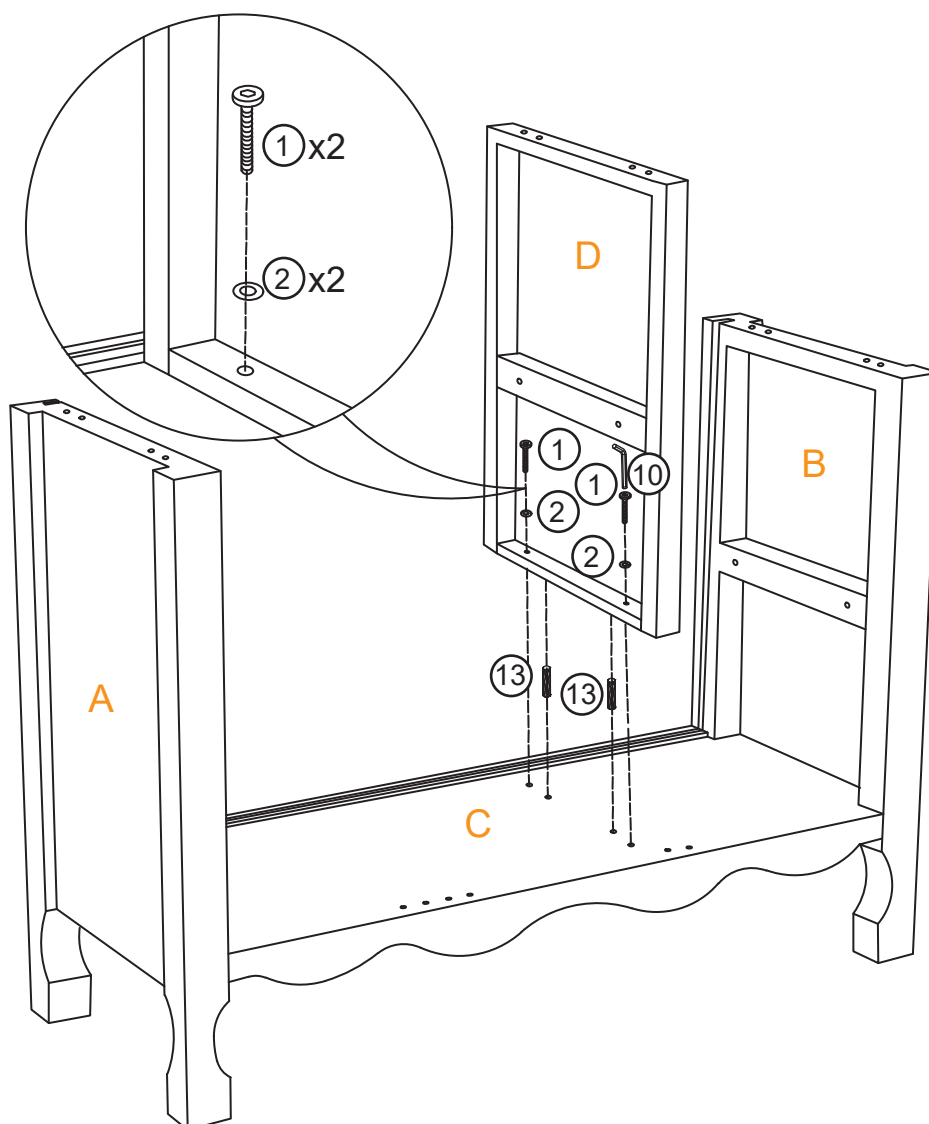
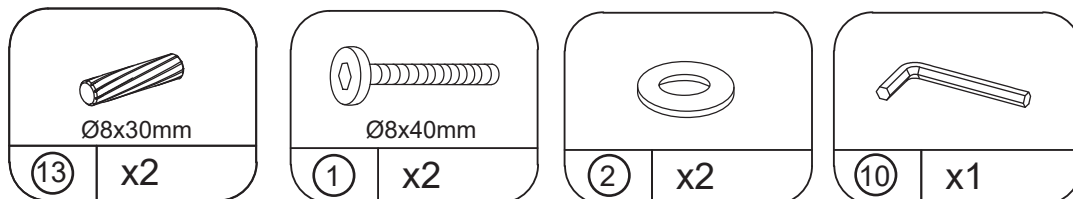

Insert the wood dowel 13 into the panel D, place washer 2 onto bolt 1, tighten the bottom of middle partition D to baseboard C, and tighten with a wrench.

STEP 3

Please tighten the screws after completing all installation.

Por favor, apriete los tornillos después de instalar todo.

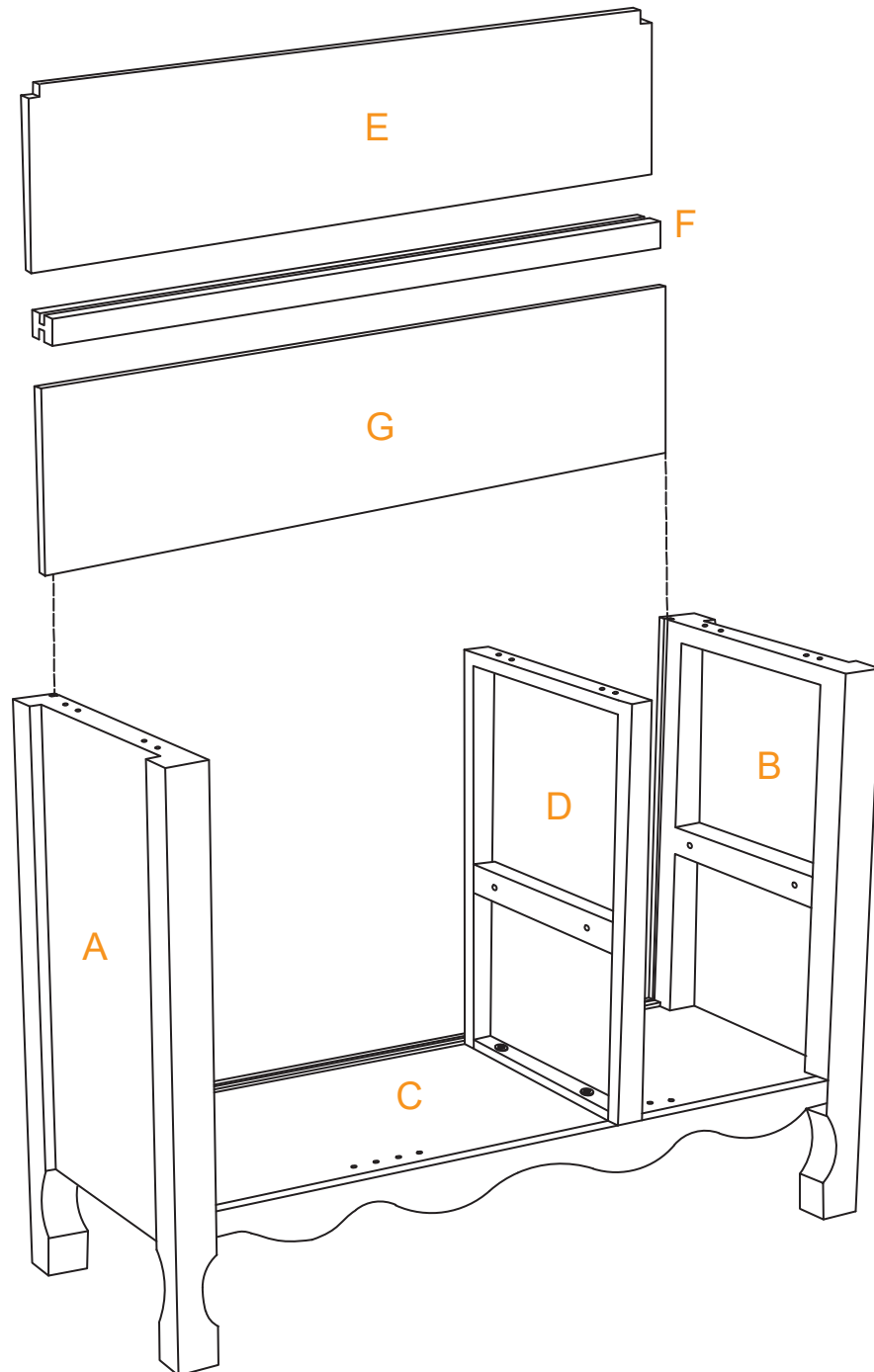

Insert the three parts G, F, E of the back panel into the back in sequence as shown in the picture, paying attention to the differences between G and E.

STEP 4

Please tighten the screws after completing all installation.

Por favor, apriete los tornillos después de instalar todo.

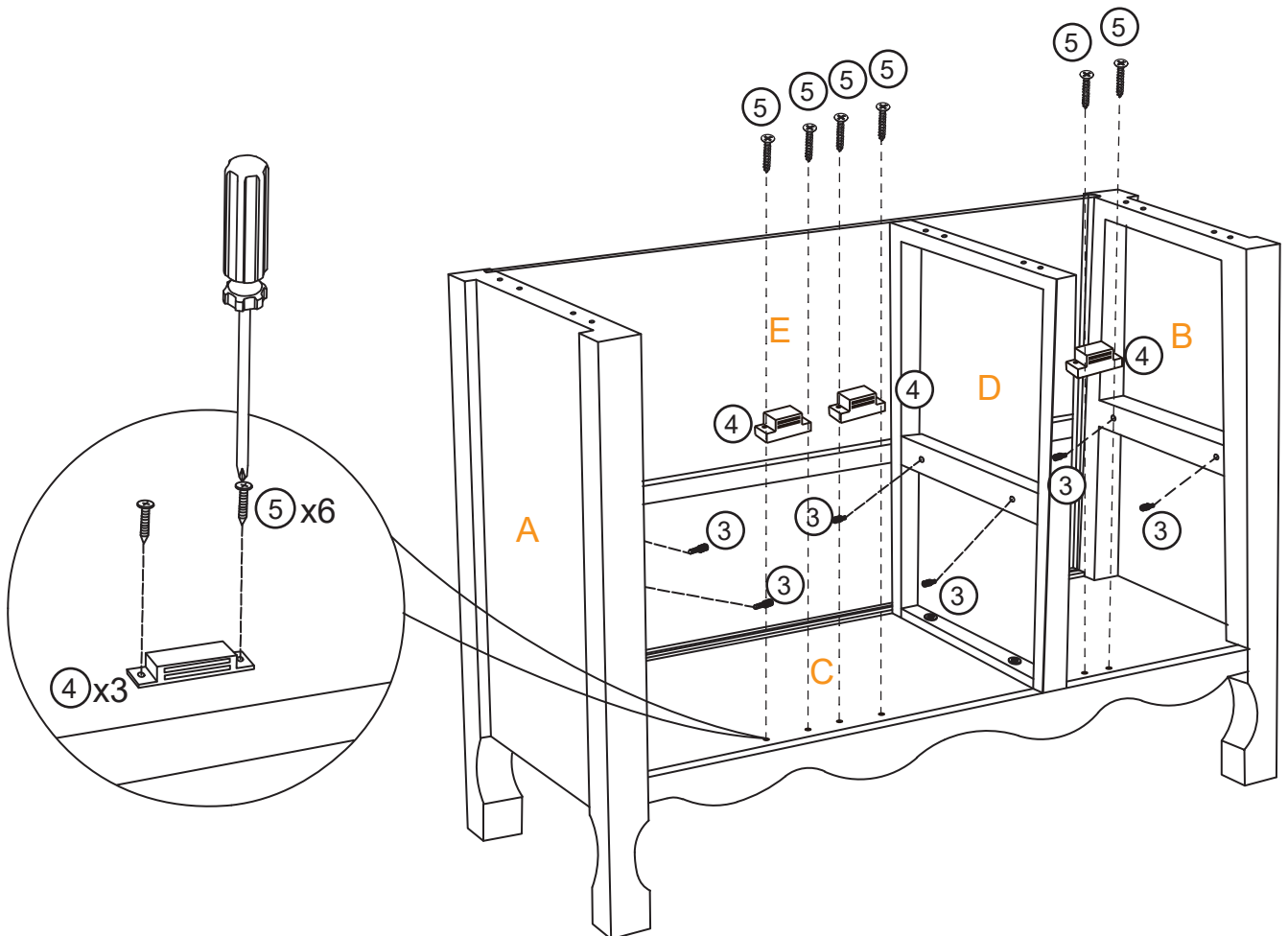
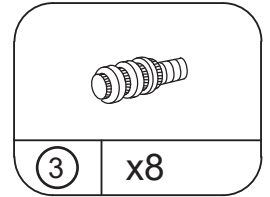
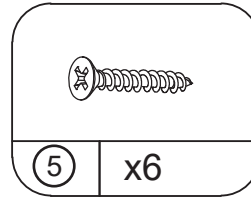
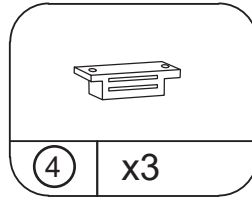
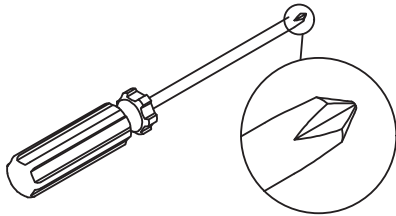

Insert 2 shelf brackets 3 into the middle of side panels A, B, and middle partition D respectively. According to the hole positions, use screw 5 to secure magnetic catch 4 with a screwdriver.

STEP 5

Please tighten the screws after completing all installation.

Por favor, apriete los tornillos después de instalar todo.

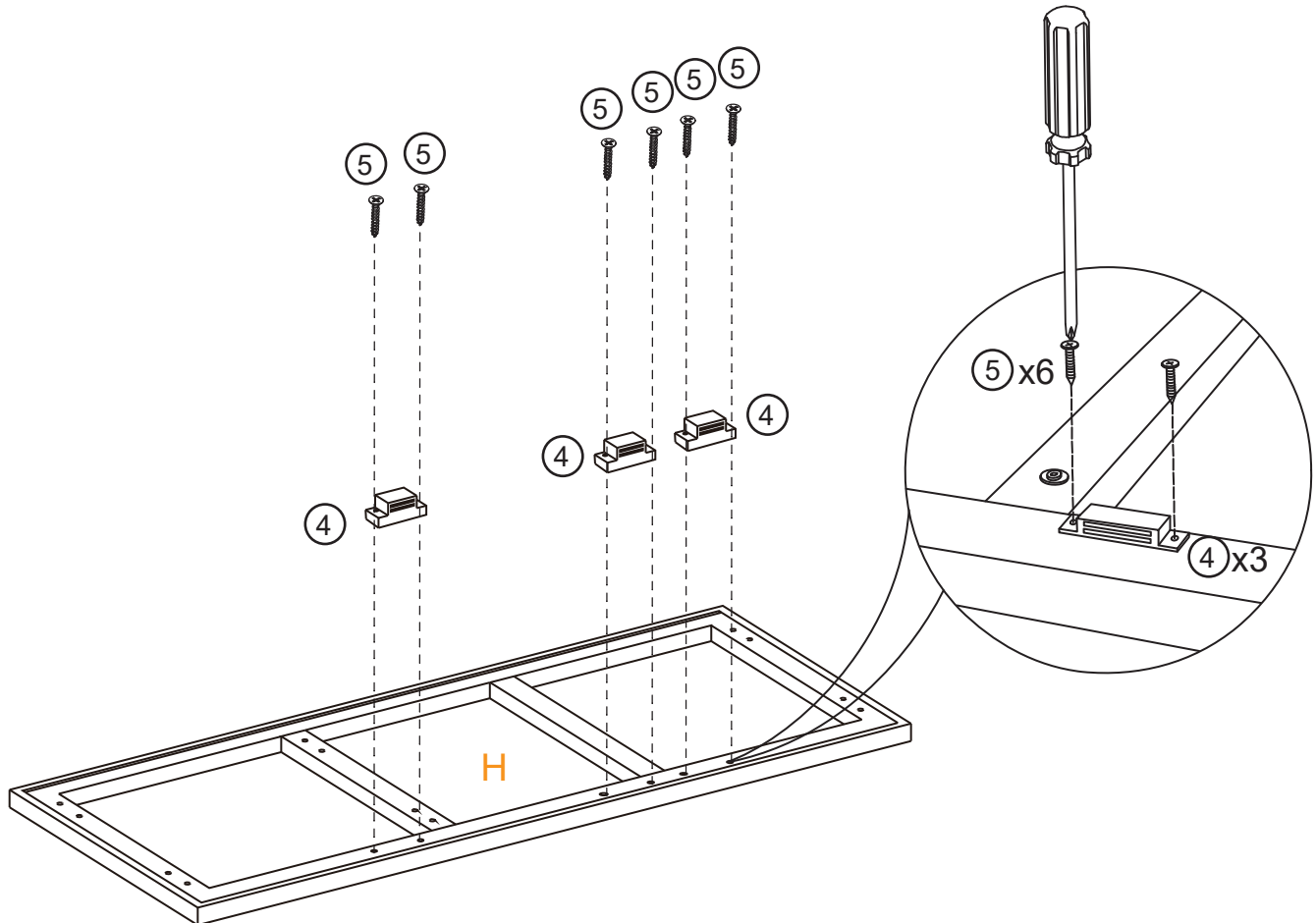
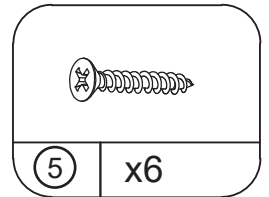
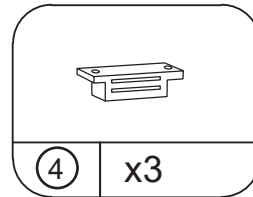
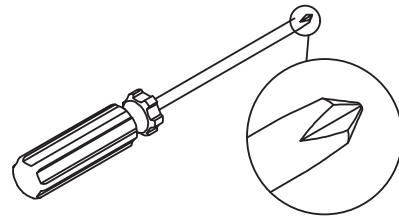

According to the hole positions, use screw 5 to secure magnetic catch 4 with a screwdriver.

STEP 6

Please tighten the screws after completing all installation.

Por favor, apriete los tornillos después de instalar todo.

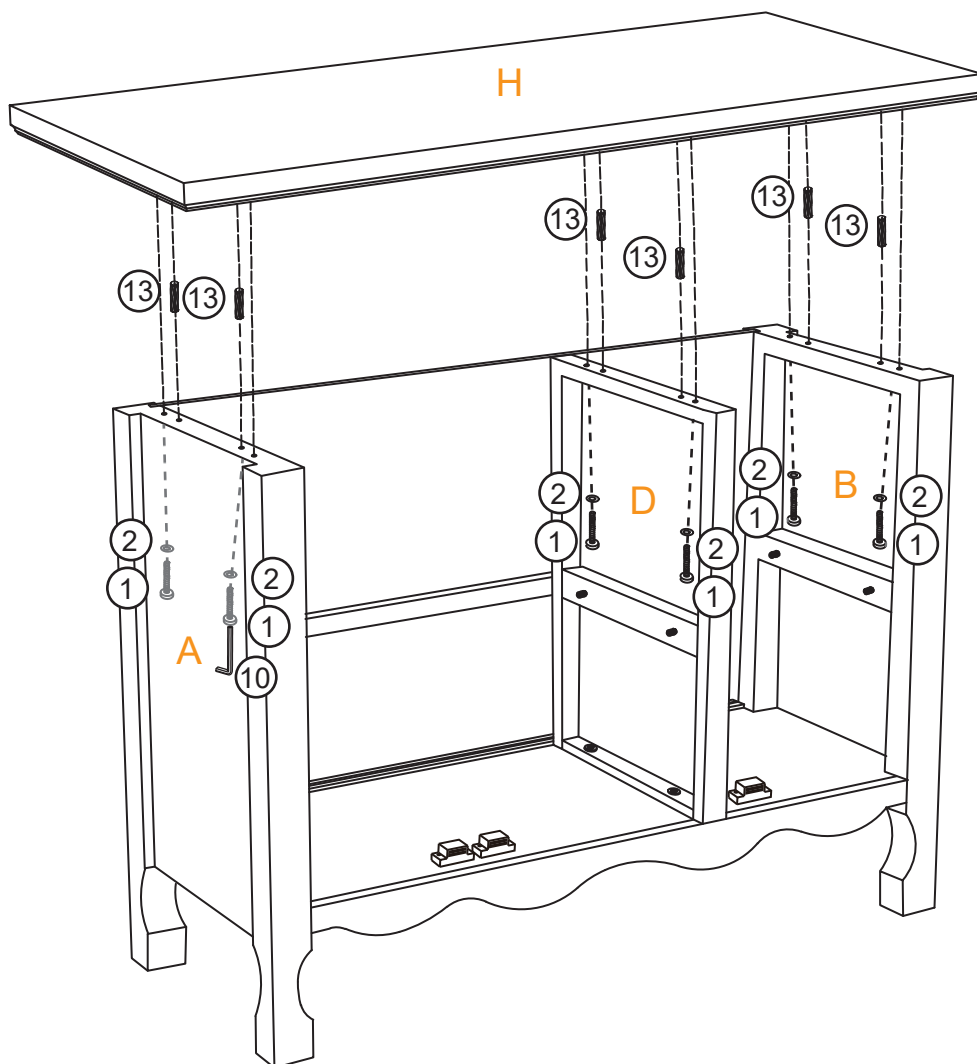
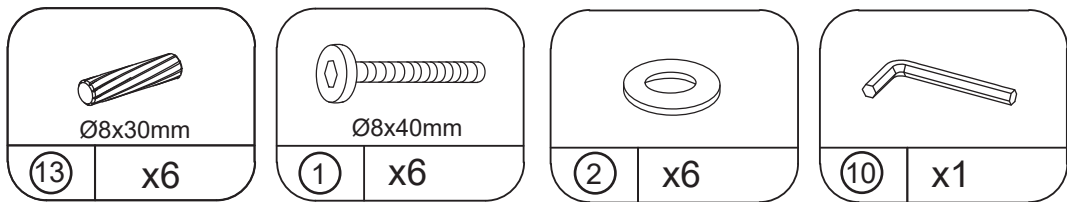

Insert the wood dowel 13 into the side panels A,B,D. Align top board H with the cabinet and cover it. After aligning the top board with the mounting holes, place washer 2 onto bolt 1, tighten the top board with a wrench on side panels A,B, and middle partition D.

STEP 7 Please tighten the screws after completing all installation.

Por favor, apriete los tornillos después de instalar todo.

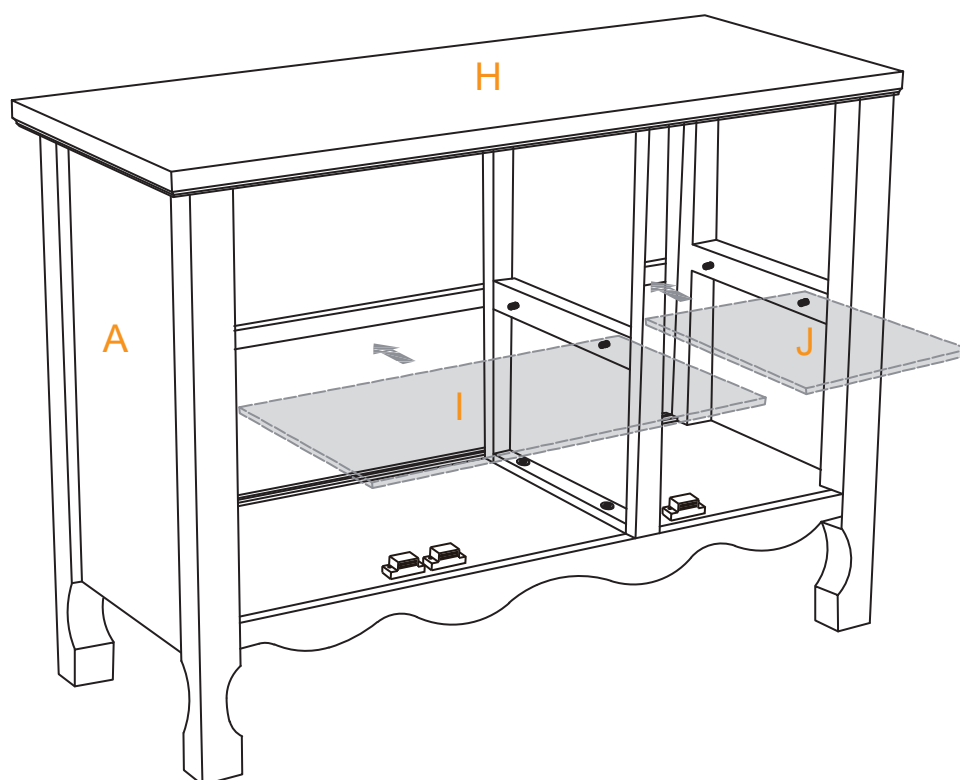

Place shelves I and J diagonally into the cabinet and level them.

STEP 8

Please tighten the screws after completing all installation.

Por favor, apriete los tornillos después de instalar todo.

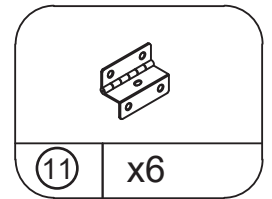
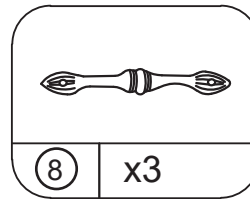
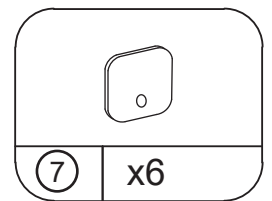
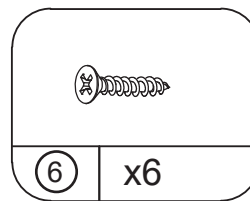
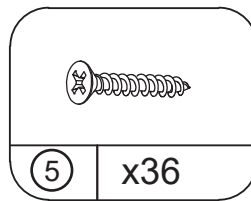
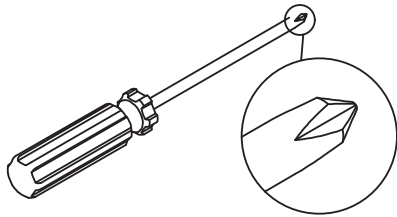

If the door cannot be closed, try loosening the four screws on the center divider panel D. Gently move the center divider panel D slightly towards the inside of the cabinet. Then, check if the cabinet door can be closed. If it closes, tighten the four screws on the center divider panel D.

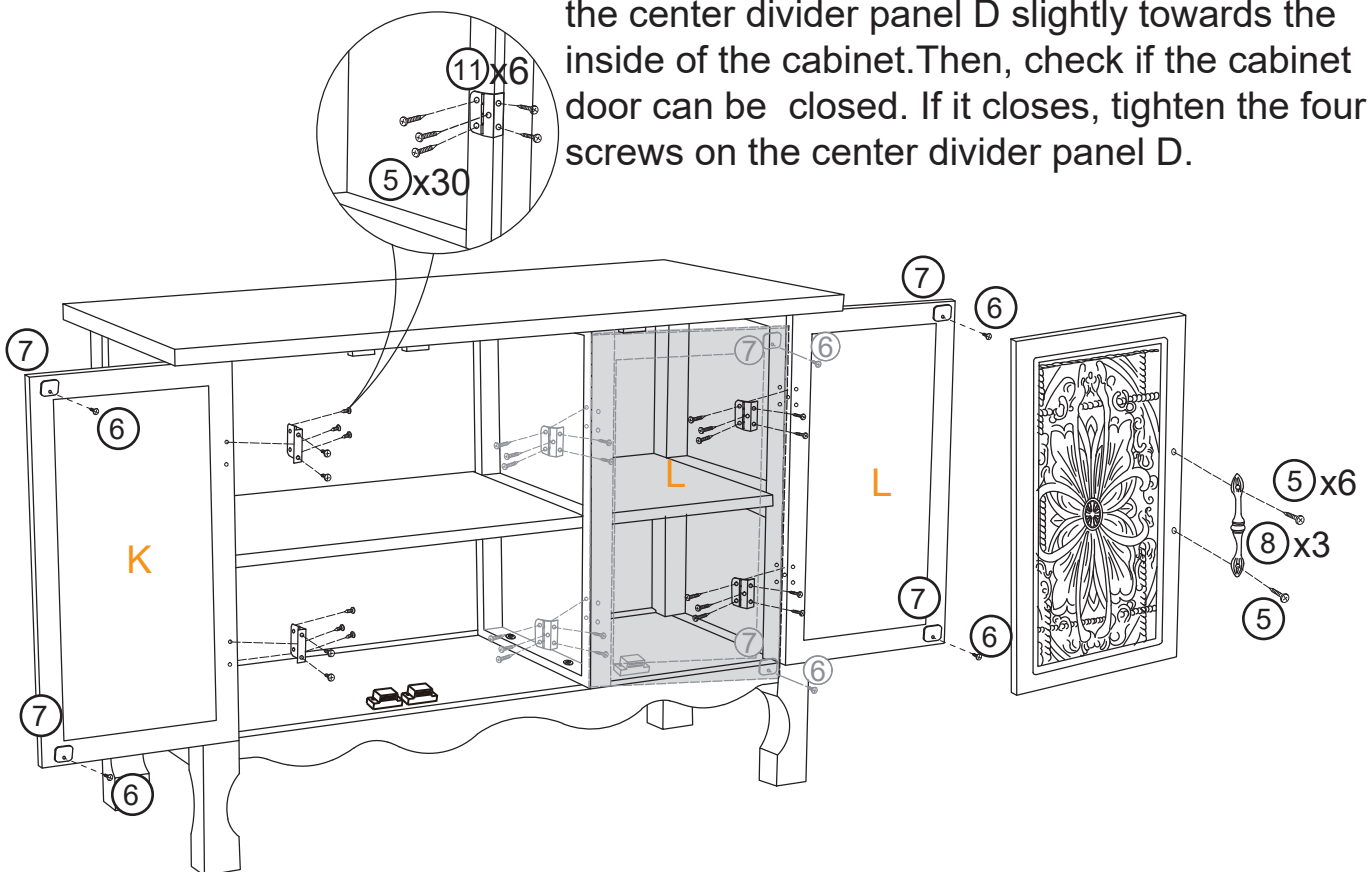

Install the door. Use a screwdriver to secure screw 6 and magnetic catch plate to the cabinet door according to the hole positions, then use a screwdriver to secure screw 5 and hinge to the cabinet. If the two doors are not aligned, it may be due to uneven floors, adjust the bottom adjusting screws to achieve levelness.

STEP 9

Please tighten the screws after completing all installation.

Por favor, apriete los tornillos después de instalar todo.

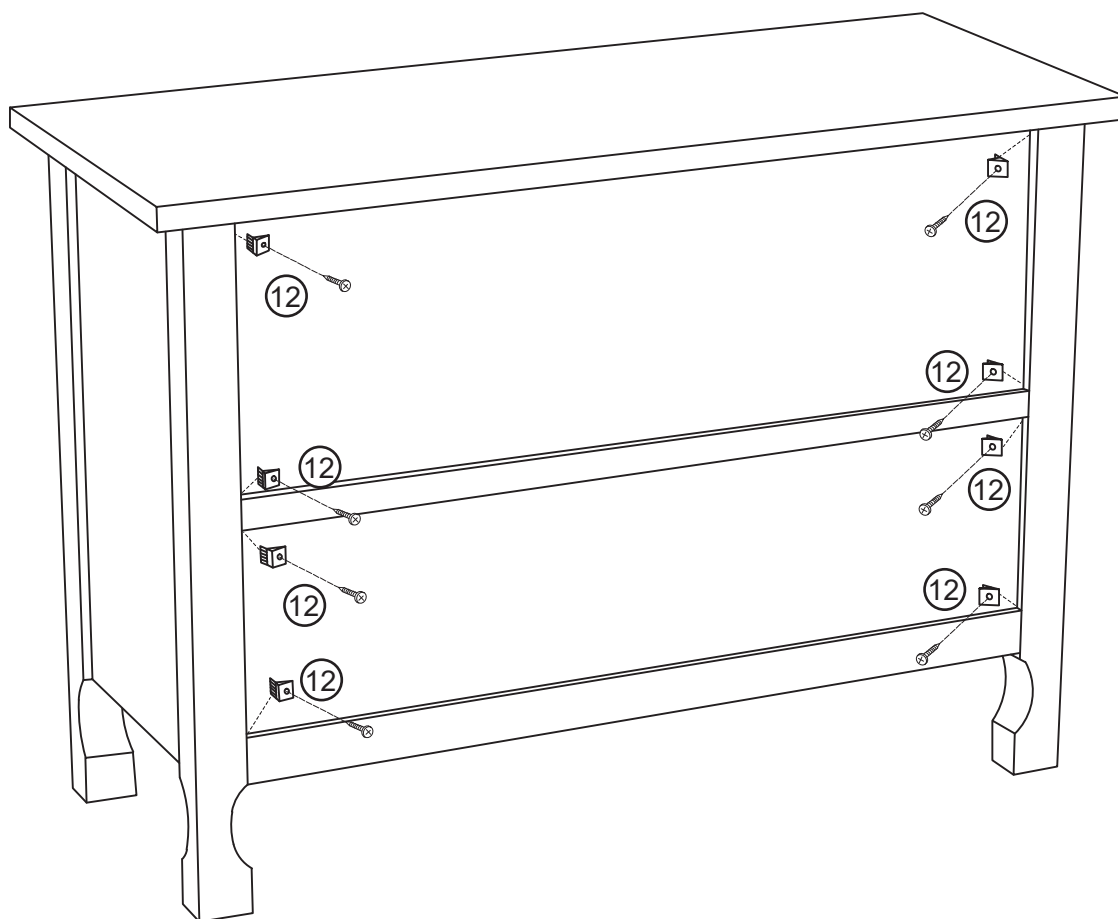
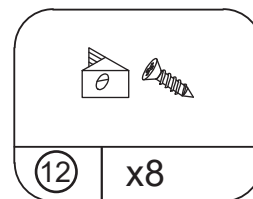

STEP 10

Please tighten the screws after completing all installation.

Por favor, apriete los tornillos después de instalar todo.

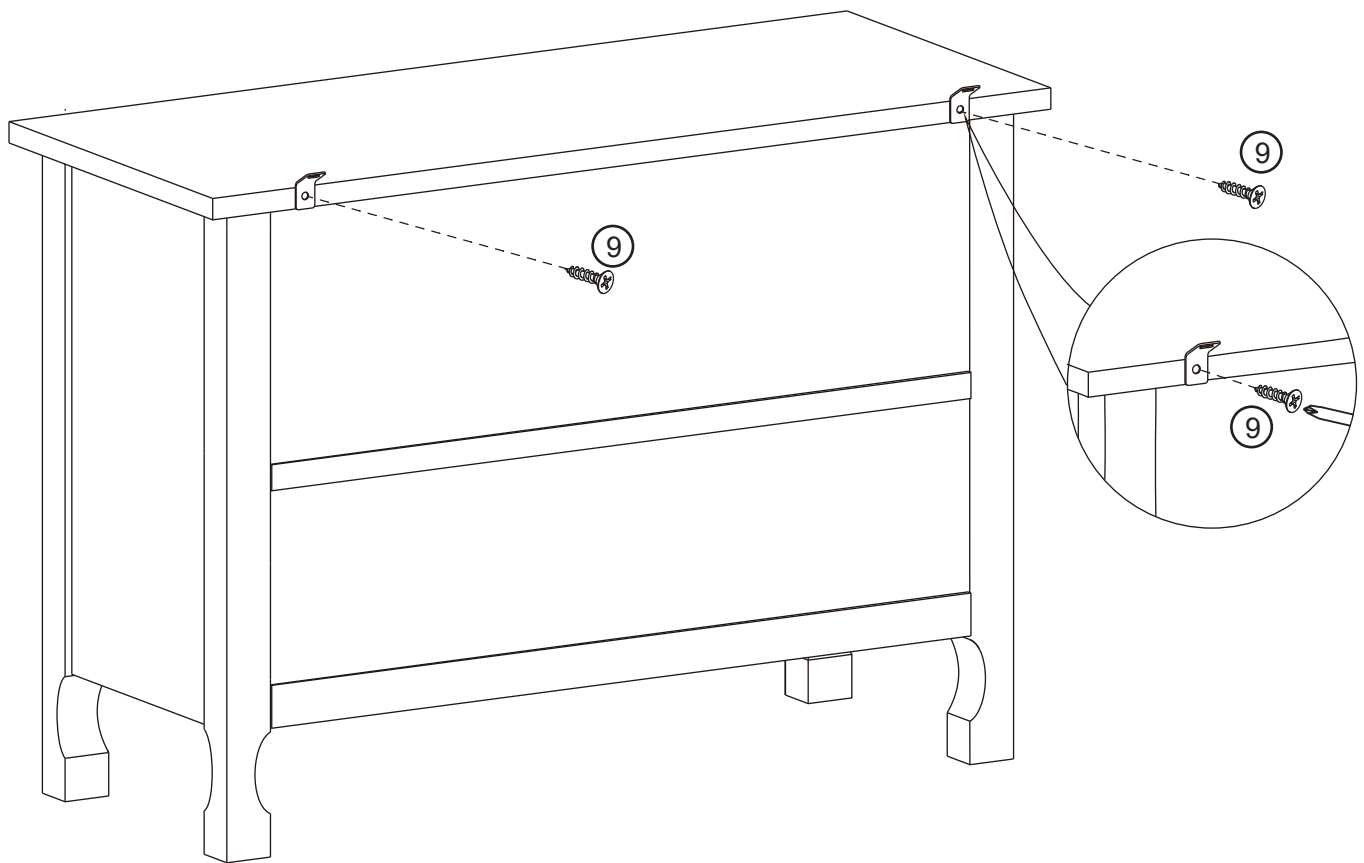
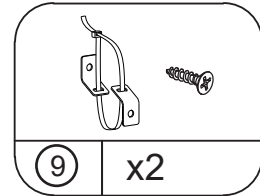

STEP 11

Please tighten the screws after completing all installation.

Por favor, apriete los tornillos después de instalar todo.

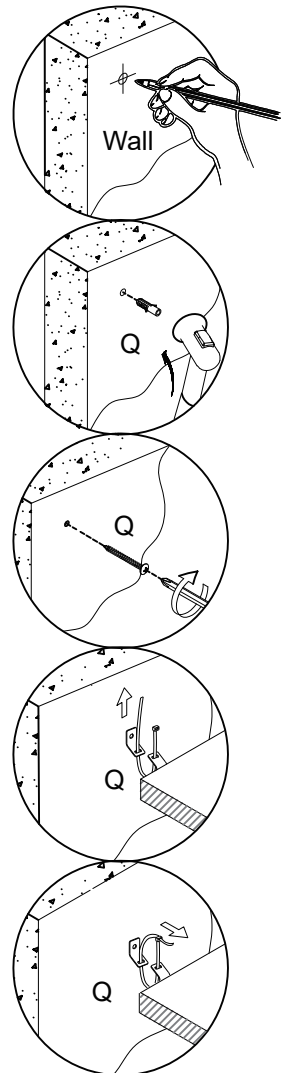
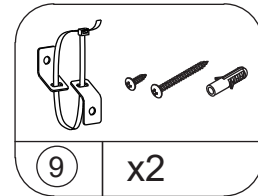
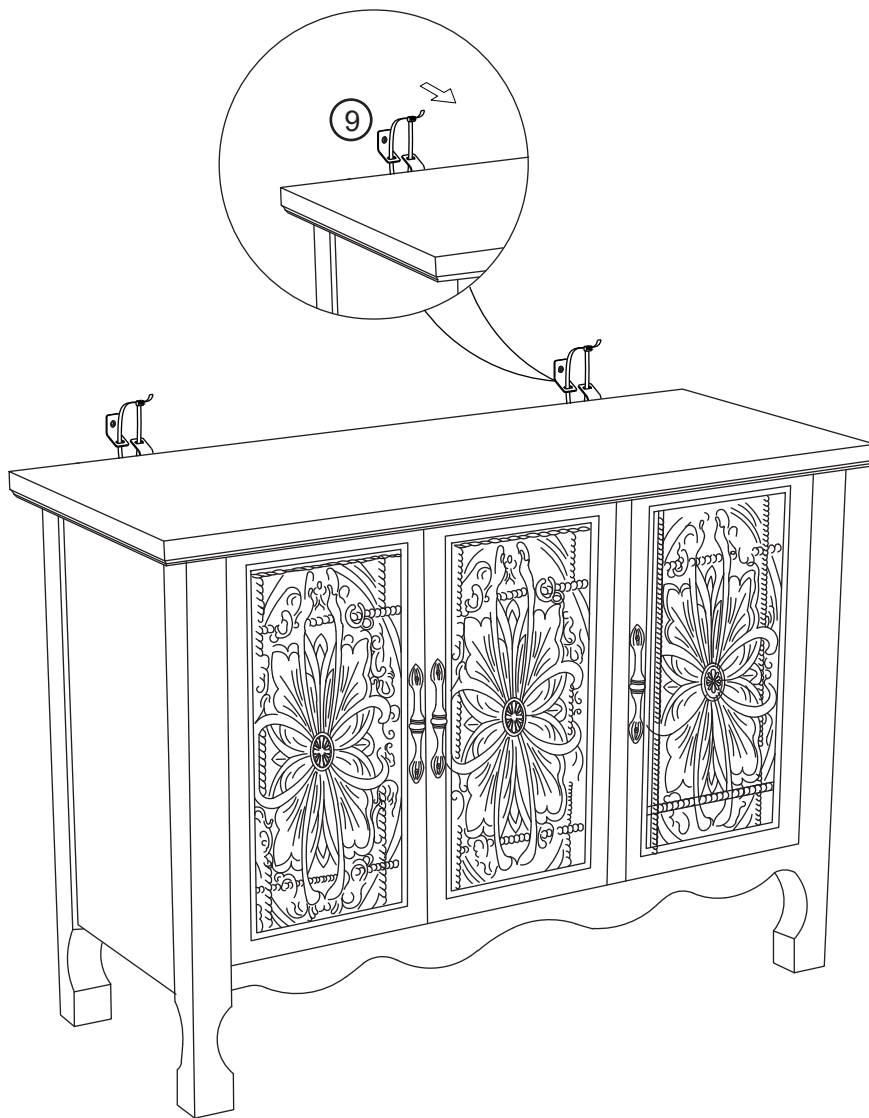

⚠ WARNING



- Children have died from furniture tip-overs. To reduce the risk of furniture tip-overs:
- Always install the provided tip-over restraint.
 - For use with televisions weighing 200 lbs or less. Using heavier televisions may result in instability, causing tip-overs and resulting in death or serious injury. Never use with CRT televisions.
 - Never allow children to stand, climb, or hang on drawers, doors, or shelves.
 - Never open more than one drawer at a time.
 - Place heaviest items in the lowest drawers.
 - Do not defeat or remove the drawer interlock system.

This is a permanent label. Do not remove it!



MAINTENANCE AND CARE

Prevent Moisture Damage:

Safeguard your laminate furniture by keeping it in a dry environment. Store the furniture away from damp areas and water sources.

Sunlight Shielding:

Shield your laminate furniture from direct sunlight to prevent color fading and surface deterioration. Consider using curtains or blinds for protection, especially if direct sunlight exposure is unavoidable.

Regular Care:

Maintain your laminate furniture's appearance by gently wiping surfaces with a damp cloth. Avoid using overly wet cloths or abrasive cleaning tools.

Avoid Scratches:

Protect the furniture surface from scratches by refraining from placing sharp or hard objects on it. When moving the furniture, be cautious not to scrape the legs against the floor.

Proper Weight Distribution:

Prevent structural damage by placing heavy objects on stable support surfaces rather than directly on the laminate furniture's surface. This simple step can prolong the life of your furniture.

Evite daños por humedad:

Proteja sus muebles laminados manteniéndolos en un ambiente seco. Guarde los muebles lejos de zonas húmedas y fuentes de agua.

Protéjalos de la luz solar:

Proteja sus muebles laminados de la luz solar directa para evitar la pérdida de color y el deterioro de la superficie. Considere el uso de cortinas o persianas como protección, especialmente si la exposición directa a la luz solar es inevitable.

Cuidado regular:

Mantenga el aspecto de sus muebles laminados limpiando suavemente las superficies con un paño húmedo. Evite utilizar paños demasiado húmedos o herramientas de limpieza abrasivas.

Evite los arañazos:

Proteja la superficie del mueble de arañazos evitando colocar objetos afilados o duros sobre ella. Al mover el mueble, tenga cuidado de no raspar las patas contra el suelo.

Distribución adecuada del peso:

Evite daños estructurales colocando objetos pesados sobre superficies de apoyo estables en lugar de directamente sobre la superficie del mueble laminado. Este sencillo paso puede prolongar la vida de sus muebles.

Warranty Coverage: Our warranty provides protection against manufacturing defects in materials and workmanship for a specified period from the date of purchase, as outlined in the accompanying warranty documentation.

Exclusions: The warranty does not cover damages resulting from misuse, negligence, accidents, normal wear and tear, unauthorized repairs or modifications, improper assembly, or failure to adhere to the care and maintenance guidelines provided.

WARRANTY CLAIM PROCESS

To initiate a return on Amazon, please follow these steps:

1. Log into your Amazon account and go to the "Your Orders" section.
2. Locate the order containing the item you wish to return.
3. Contact our customer service for assistance in obtaining a prepaid return label.
4. Once you receive the return label, securely affix it to the package.
5. You can then choose to drop off the package at a designated carrier location or arrange for a pickup.
6. After we receive and inspect the returned product, we will initiate the refund process.
7. The refund will be credited back to the original payment method used during the purchase.
8. Typically, refunds are processed within 3-5 business days.

Warranty Coverage: Our warranty provides protection against manufacturing defects in materials and workmanship for a specified period from the date of purchase, as outlined in the accompanying warranty documentation.

Exclusions: The warranty does not cover damages resulting from misuse, negligence, accidents, normal wear and tear, unauthorized repairs or modifications, improper assembly, or failure to adhere to the care and maintenance guidelines provided.

PROCESO DE RECLAMACIÓN DE LA GARANTÍA

Para iniciar una devolución en Amazon, siga estos pasos:

1. Accede a tu cuenta de Amazon y ve a la sección "Tus pedidos".
2. Localiza el pedido que contiene el artículo que deseas devolver.
3. Ponte en contacto con nuestro servicio de atención al cliente para que te ayuden a obtener una etiqueta de devolución prepagada.
6. Después de que recibamos e inspeccionemos el producto devuelto, iniciaremos el proceso de reembolso.
7. El reembolso se abonará de nuevo al método de pago original utilizado durante la compra.
8. Normalmente, los reembolsos se procesan en un plazo de 3 a 5 días laborables.
4. Una vez que reciba la etiqueta de devolución, fíjela firmemente al paquete.
5. A continuación, puede optar por depositar el paquete en el lugar designado por el transportista o solicitar que lo recojan.