

Read this instruction carefully. See hardware and furniture part list for guidance. Be sure all parts are complete, before you assemble. Place all wooden furniture parts on a clean and flat soft surface to prevent from being scratched. Follow the figure to start assembling.

**CAUTIONS :** 1. Do not FULLY - TIGHTEN the nut or nut bolt until all nut or bolt is ready assembled.  
2. Do not OVER - TIGHTEN the nut or bolt to avoid causing damages to the thread.  
3. Keep all hardware parts out of reach of children.

**NOTE :** THE LIST AND QUANTITY SHOWN ARE FOR 1 UNIT ASSEMBLY.  
Tool needed : Screwdriver (not provider).

PART LIST		
ITEM	DESCRIPTION	QTY
A	HEADBOARD	1 PC
B	FOOTBOARD	1 PC
C	SIDE RAIL	2 PCS
D	CENTER RAIL	1 PC
E	CENTER SUPPORT	2 PCS
F	CENTER SUPPORT LEG	3 PCS
G	BED SLAT	24 PCS
H	BED LEG	4 PCS
I	HEADBOARD & FOOTBOARD SUPPORT WOOD	2 PCS

HARDWARE LIST		
ITEM	DESCRIPTION	QTY
1	JCBC BOLT M6 x 40mm	4 PCS
2	JCBB BOLT M8 x 40mm	6 PCS
3	WOOD SCREW M3.5 x 16mm	8 PCS
4	WOOD SCREW M4 x 20mm	2 PCS
5	M8 FLAT WASHER	6 PCS
6	M8 SPRING WASHER	6 PCS
7	BED SLAT SIDE FITTER	24 PCS
8	BED SLAT CENTER FITTER	12 PCS
9	M4 ALLEN KEY (BALL SHAPE)	1 PC
10	M5 ALLEN KEY (BALL SHAPE)	1 PC

## STEP 1

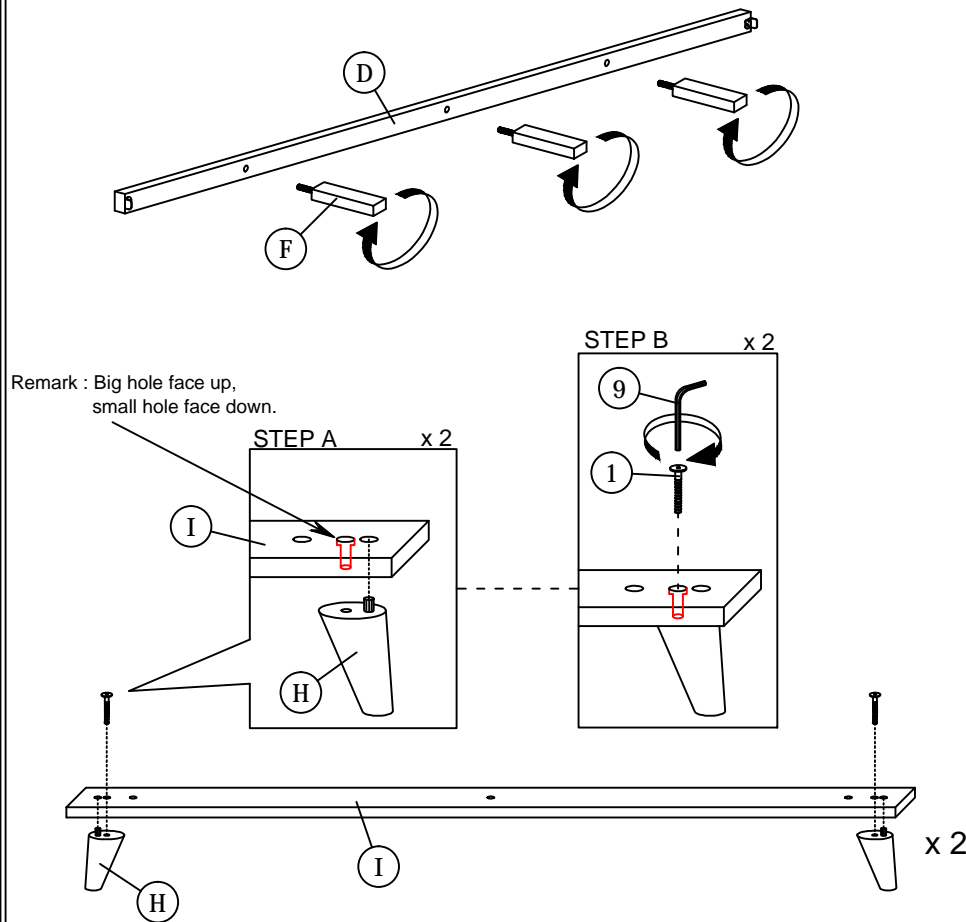

## STEP 2

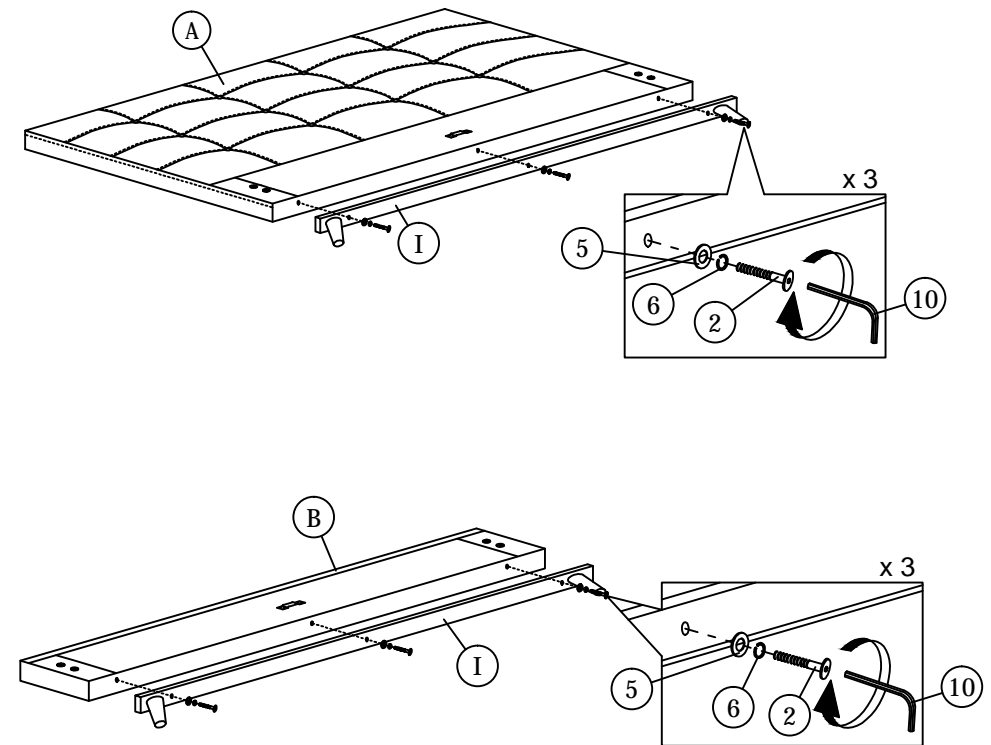

# ASSEMBLY INSTRUCTIONS

STEP 3

STEP A

STEP B

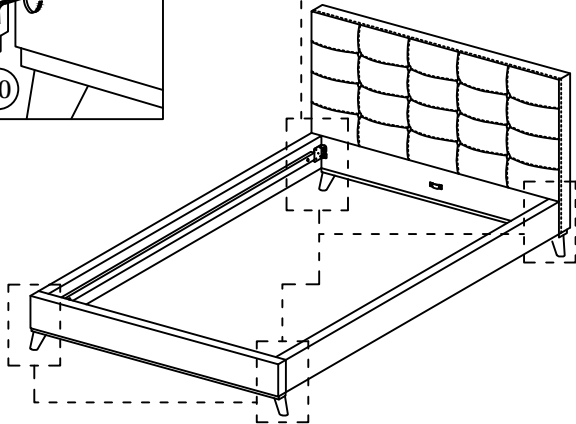
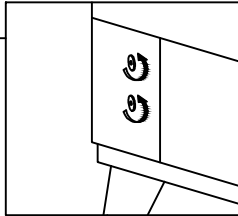
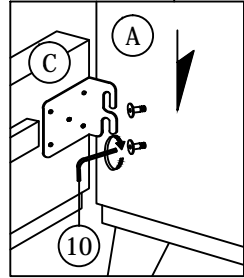

STEP 4

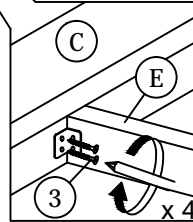
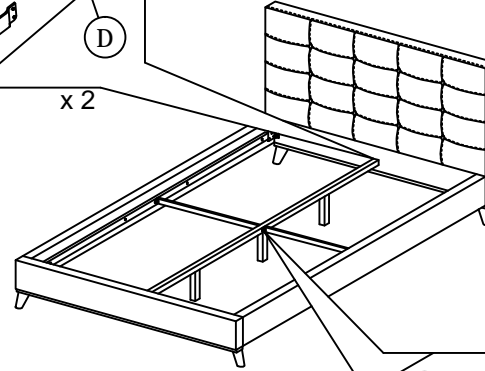
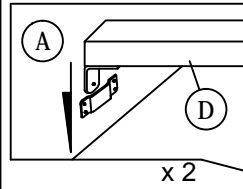

Note: Assemble (E) vertically as picture shown.

STEP 5

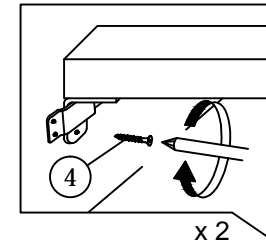

STEP 6

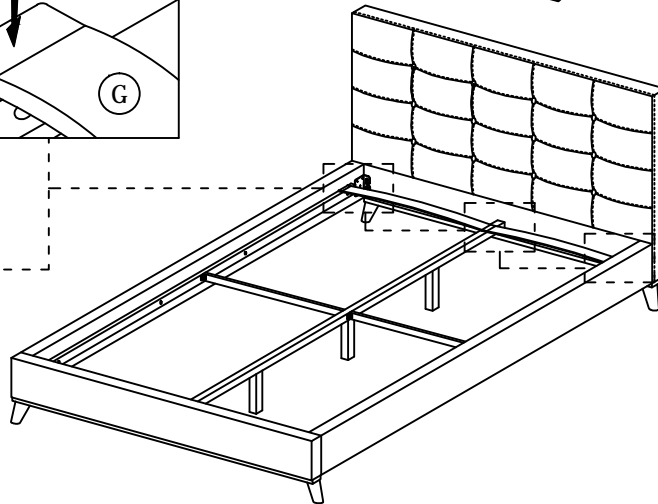
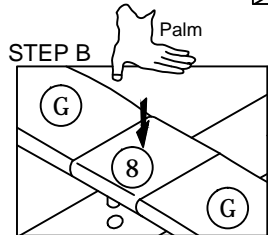
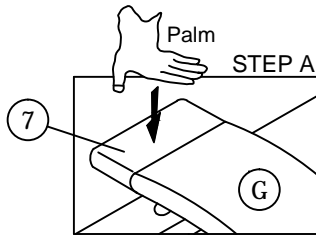
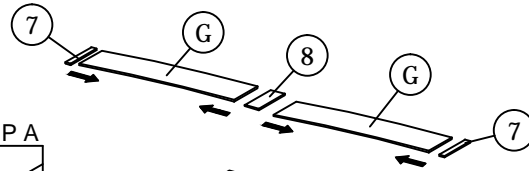

STEP 7

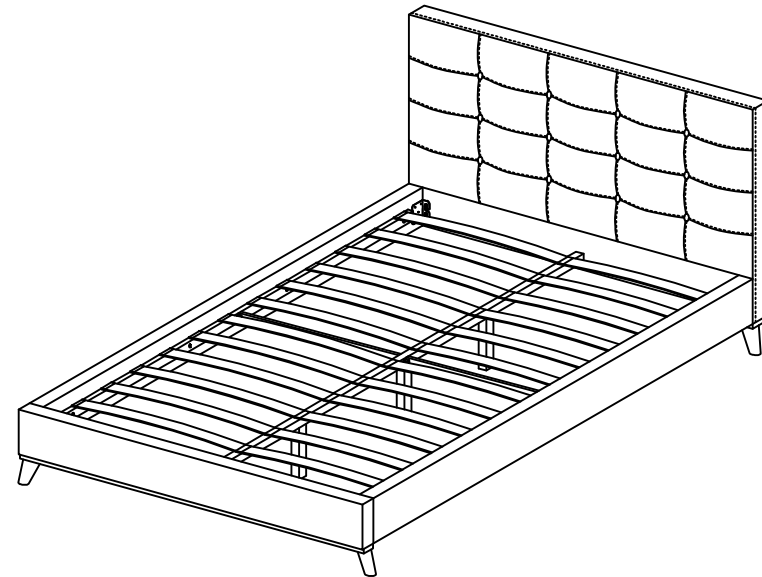

\* When moving the bed position, the center support legs must be adjust to be straight to avoid any broken problem.