

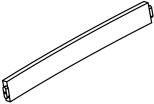
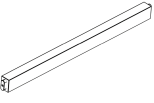
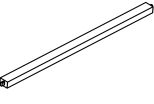
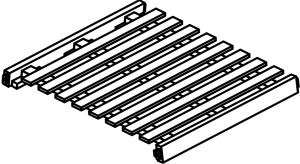
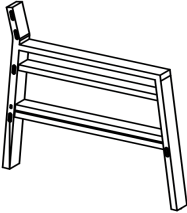
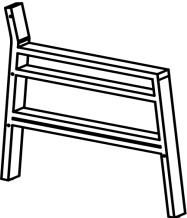
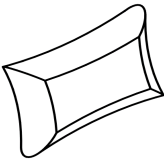
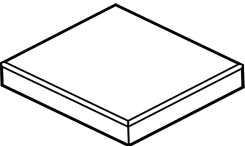

Hello! Please read these important attentions...

Please put a thick carpet on the ground to protect the furniture finish and corners. During the installation process, **DON' T** fasten screws tight 100% at a time.

ASSEMBLY INSTRUCTION

NUMBER	COMPONENT	QUANTITY
A	 Upper Back Slat	2
B	 Middle Back Slat	1
C	 Lower Back Slat	1
D	 Seat Panel	1
E	 Right Leg Panel	1
F	 Left Leg Panel	1
G	 Back Cushion	1
H	 Seat Cushion	1

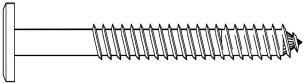
ASSEMBLY INSTRUCTION

NUMBER	COMPONENT	QUANTITY
①	 <p align="center">Screw (M6*90mm)</p>	9
②	 <p align="center">Allen Wrench</p>	2

Assembly Preparation :

Before Beginning Assembly:

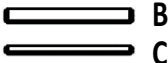
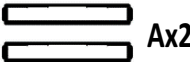
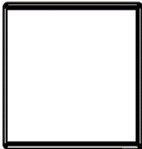
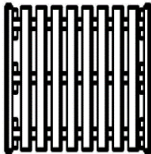
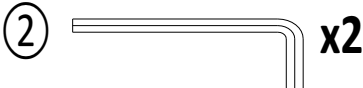
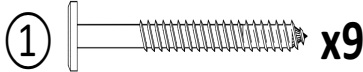
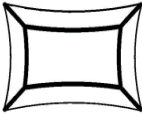
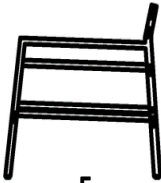
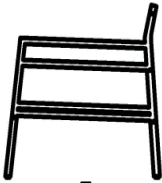

ASSEMBLY INSTRUCTION

Overview:

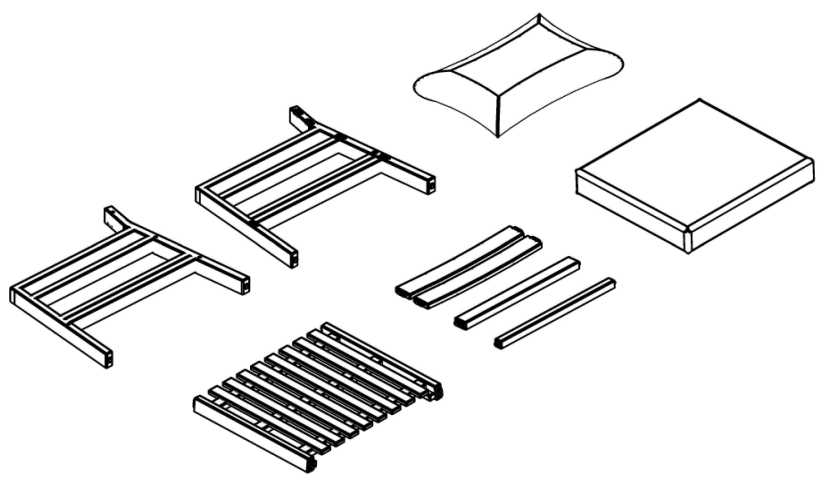
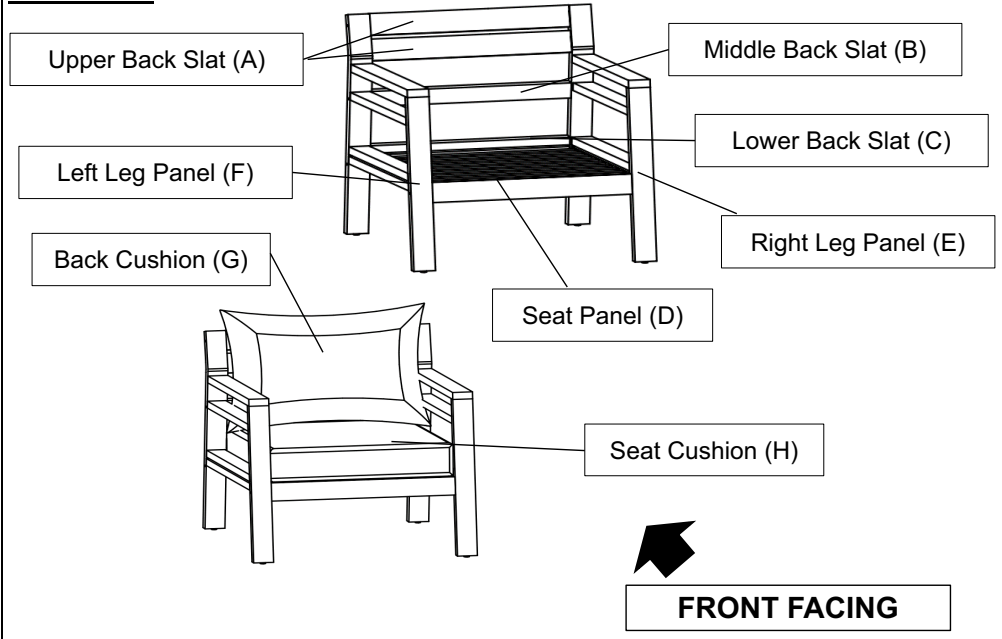

ASSEMBLY INSTRUCTION

①

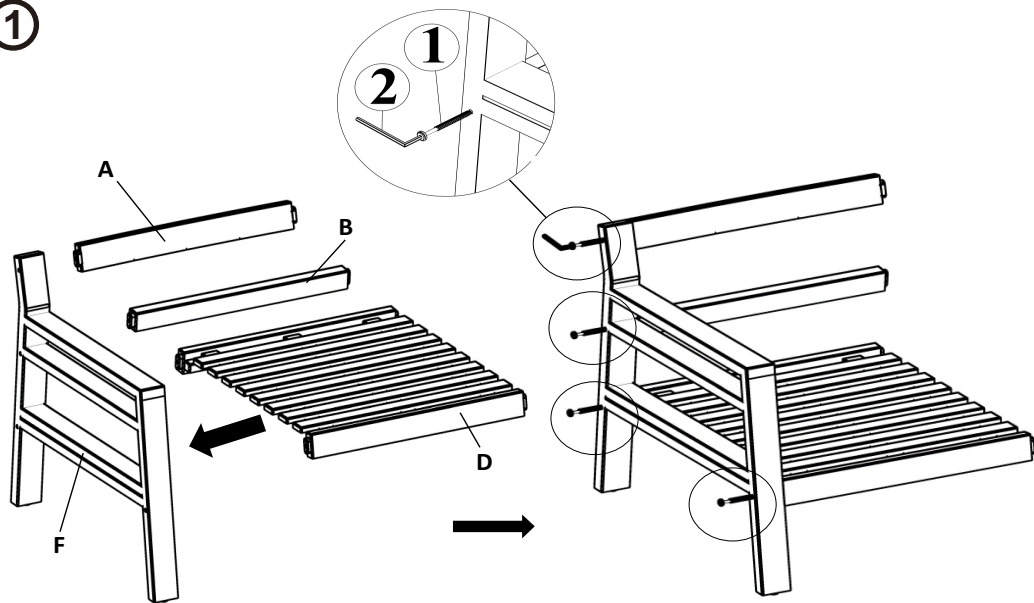

With the help of your adult partner, put the tenon of Upper Back Slat (A), Middle Back Slat (B) and Seat Panel (D) into the mortise of the Left Leg Panel (F) and then secure by using Screw (1) and Allen Wrench (2) as shown above.

Note : only eighteen 80%.

②

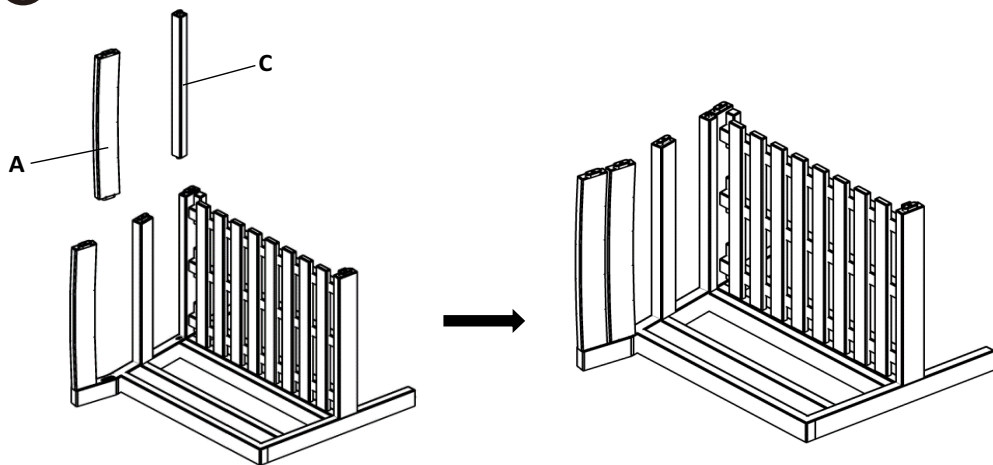

With the help of your adult partner, turn left side down the assembled part in Step 2 on a clean, non-marring surface.

Put the tenon of the remaining Upper Back Slat (A) and the Lower Back Slat (C) to the mortise of the Seat Panel (D) of the assembled part in Step 2 as shown above.

ASSEMBLY INSTRUCTION

③

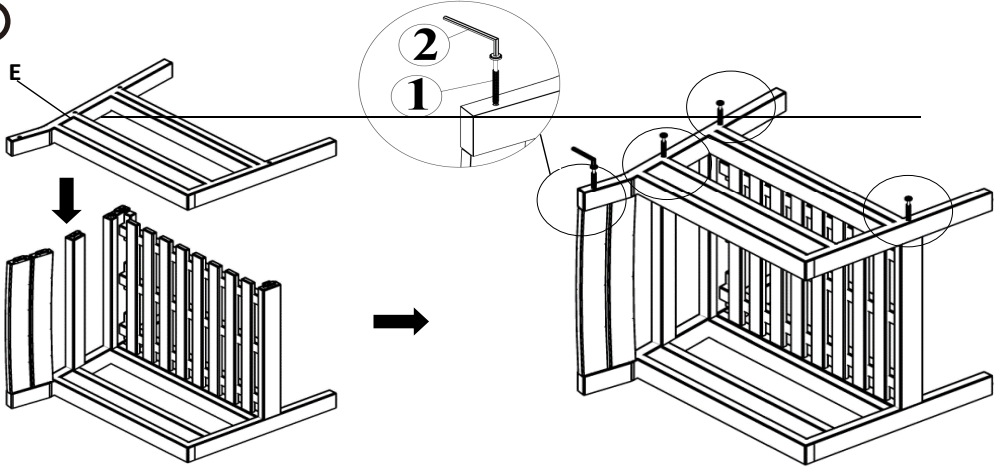

With the help of your adult partner, attach the Right Leg Panel (E) to the assembled part of Step 3 and then secure by using Screws (1) and Allen Wrench (2) as shown above.

④

