

# Dining Buffet Instructions

Instructions for the buffet types pictured below. Please identify the following items.

**Hardware included:**

- Shelf pins (4 – a, b, c, d, e, f; 8 – g, h, i)
- Silverware tray (1) (buffets with drawers)

**Component included:**

- Shelf (1 – a, b, c, d, e, f; 2 – g, h, i)

**One shelf**

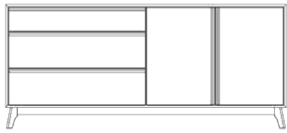

**a** 3 drawers on left, 2 doors on right buffet

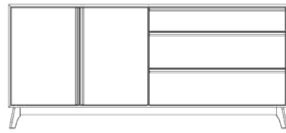

**b** 3 drawers on right, 2 doors on left buffet

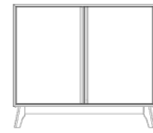

**c** 2 door buffet

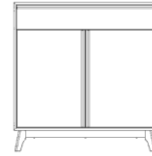

**d** 1 drawer over 2 door buffet

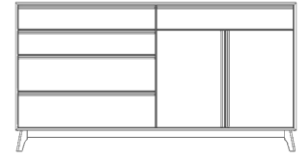

**e** 4 drawers on left, 1 drawer over 2 doors on right buffet

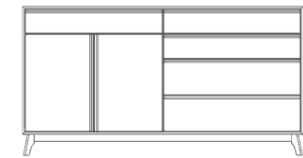

**f** 4 drawers on right, 1 drawer over 2 doors on left buffet

**Two Shelves**

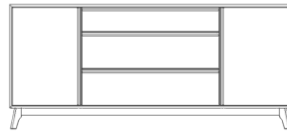

**g** 1 door on either side of 3 drawers buffet

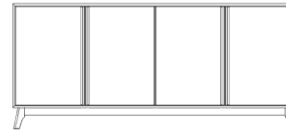

**h** 4 door buffet

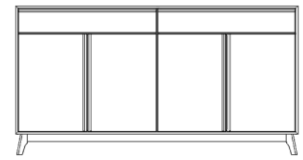

**i** 2 drawers over 4 door buffet



**Tools required** None

**Step 1:** Insert shelves in doors

Open the doors. Insert shelf support pins into the holes and carefully place the shelf on them (*Figure 1*).

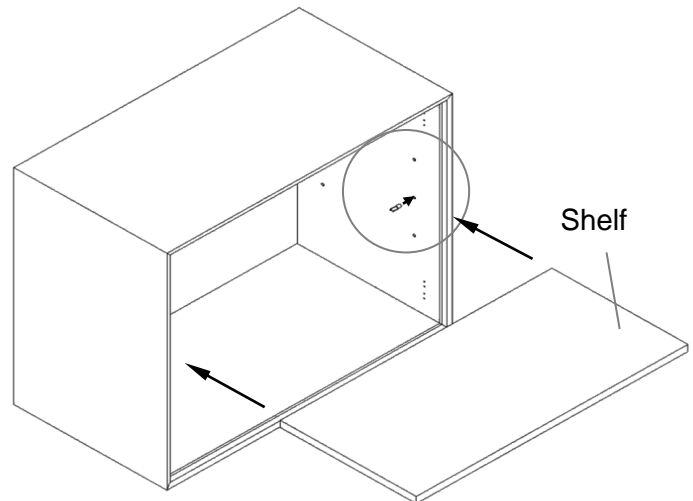
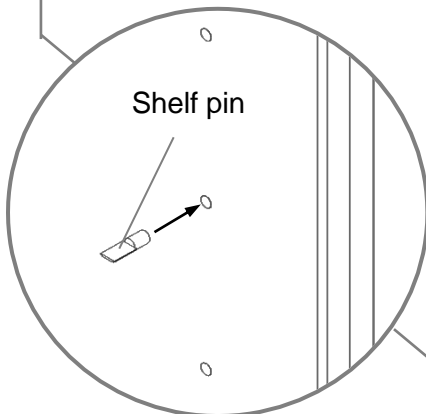

**Figure 1.** Install the shelves

# Adjust drawer slides and doors



Tools required None

## How to release the drawer slides

To remove drawers from the slides, press both handles on the front slide clips on the drawer bottom and firmly pull drawer forward (*Figure 1*).

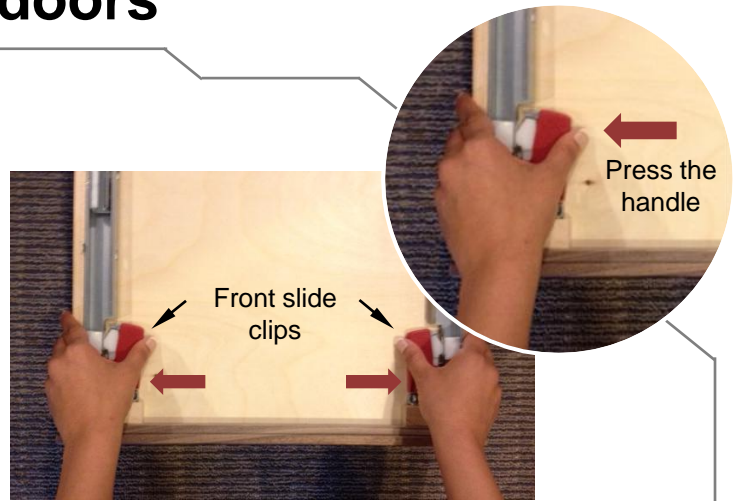

Figure 1. Release the slides

## How to reinstall the drawer

Fully extend the drawer slides (from the case) and place drawer box on top of the slides. Pull each slide forward until it locks into both left and right slide clips. You will hear a locking “click” when the slide is locked properly (*Figure 2*). After the drawers are installed, they can be further leveled by sliding the small adjustment knob forward or back. This raises or lowers the drawer box in the case (*Figure 3*).

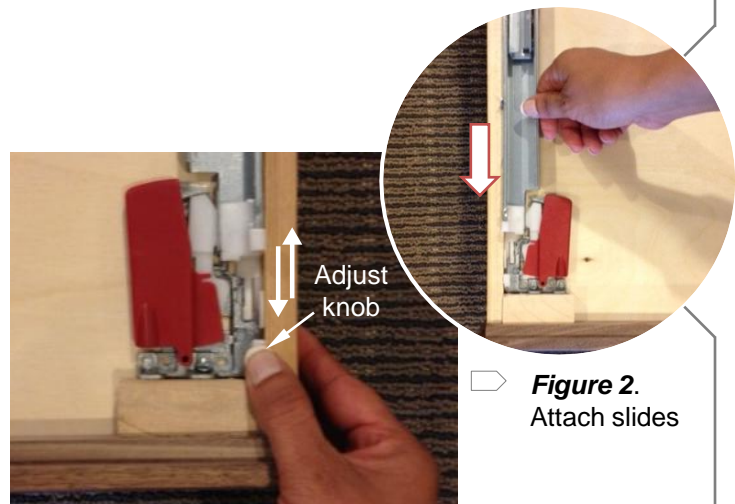

Figure 2. Attach slides

## How to level doors (for cases with doors)

If your case has a door, it can be leveled by adjusting two hinges. There are three screws on each hinge and each can be adjusted independently (*Figure 4*). The first screw can adjust the door in the left and right direction. The second screw can adjust the door up and down. The third screw can move the door in and out. Please adjust your door accordingly.

Figure 3. Adjust slides

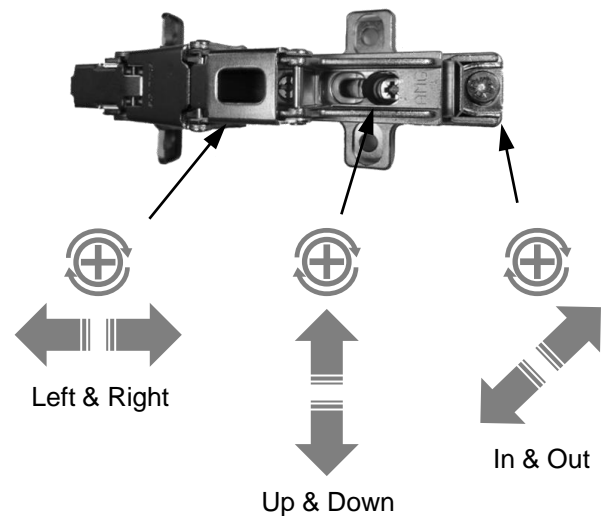
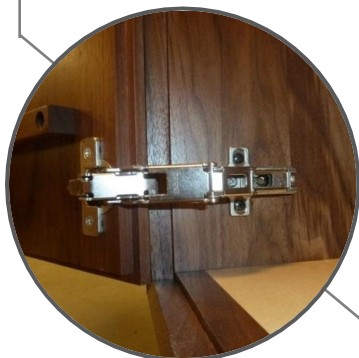

Figure 4. Adjust the door(s) by turning the screws on the hinge.



## Safety Notification

Copeland Furniture is in compliance with ASTM's volunteer Standard Safety Specification for Clothing Storage Units (2014 revision) – commonly known as the furniture tip-over standard. It is strongly recommended that you install the anti-tip stop included with your furniture to help prevent a potential top-over of the furniture onto a small child.

For more information, please visit [www.astm.org/Standards/F2057.htm](http://www.astm.org/Standards/F2057.htm).

## Care Instructions

To care for and preserve the finish on your new Copeland Furniture piece, please keep the following recommendations in mind.

- While our furniture has been finished with a durable top coat, the surface may be sensitive to dents and abrasions during the first 30 days in your home.
- Treat the surface finish gently so it does not dent or chip. Tape or stickers should not be put on the finish.
- For general care use a soft cloth to dust the furniture.
- Use damp cloth with a mild soap to clean-up spills or dirt. Dry the surface thoroughly.
- Please do not use any polishes, waxes or solvents to clean the surface of the furniture. This holds true for new Copeland Furniture pieces as well as items you may already have in your home.
- Please do not place any candles directly on the surface of your furniture. The perfumes and dyes in the candles may penetrate the finish.
- Beds must be disassembled before moving to avoid damage. Never attempt to move the bed while it is assembled.

### Special Care Instructions for Cherry Furniture

Furniture crafted from cherry wood darkens with age. This change in color, from a reddish tan to a reddish brown, results from the natural oxidation of the wood when it is exposed to light. Objects left on a piece of cherry furniture for an extended period will retard this oxidation process and when removed, may leave a lighter colored outline of the object on the surface. With continued exposure to light, this color difference will eventually disappear and the wood will reach a mature even tone.

