

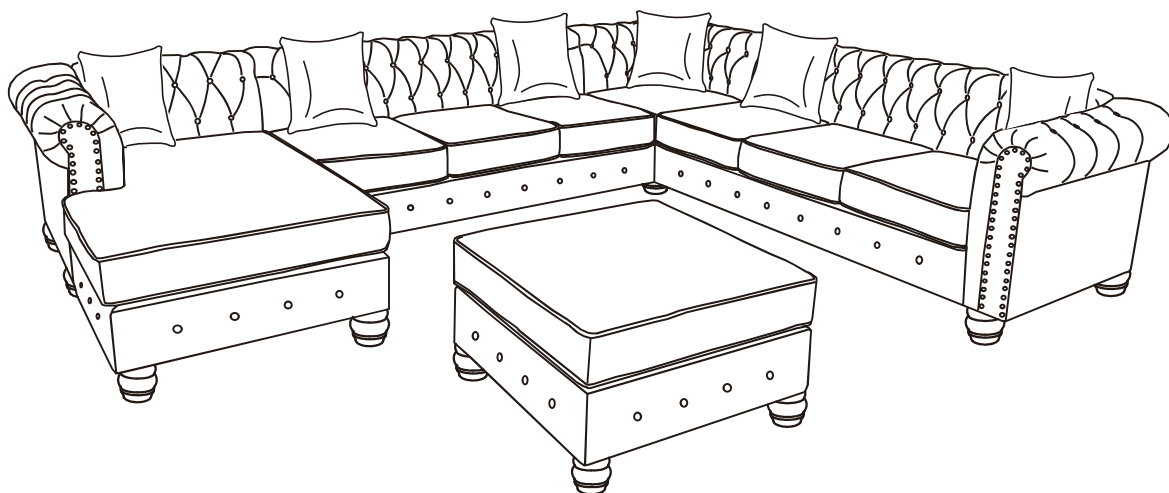

ASSEMBLY INSTRUCTION







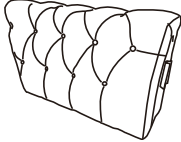

SOFA is packed in 9 cases

Carton	Disignation	Part	Hardware&Leg
1/9	Chaise seat frame	#1	#A X 
	Chaise cushion	#2	
	Pillow	#3	
2/9	Sofa seat frame	#4	
	Sofa cushion	#5	
3/9	Sofa backrest	#6	
4/9	Corner seat frame	#7	#A X 
	Corner cushion	#8	

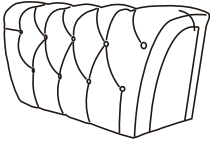
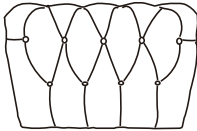
ASSEMBLY INSTRUCTION

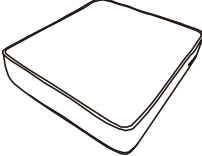
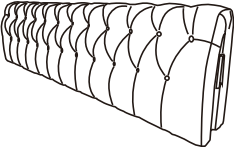
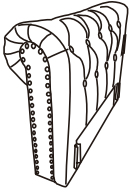
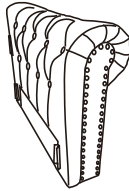
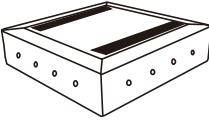
SOFA is packed in 9 cases

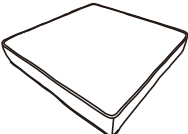
Carton	Disignation	Part		Hardware&Leg
5/9	Corner right backrest	#9		#B X 
	Corner left backrest	#10		
	Chaise backrest	#11		
6/9	Sofa seat frame	#4		
	Sofa cushion	#5		
7/9	Sofa backrest	#6		
8/9	Left arm	#12		
	Right arm	#13		
9/9	Ottoman seat frame	#14		#A X 
	Ottoman cushion	#15		

ASSEMBLY INSTRUCTION

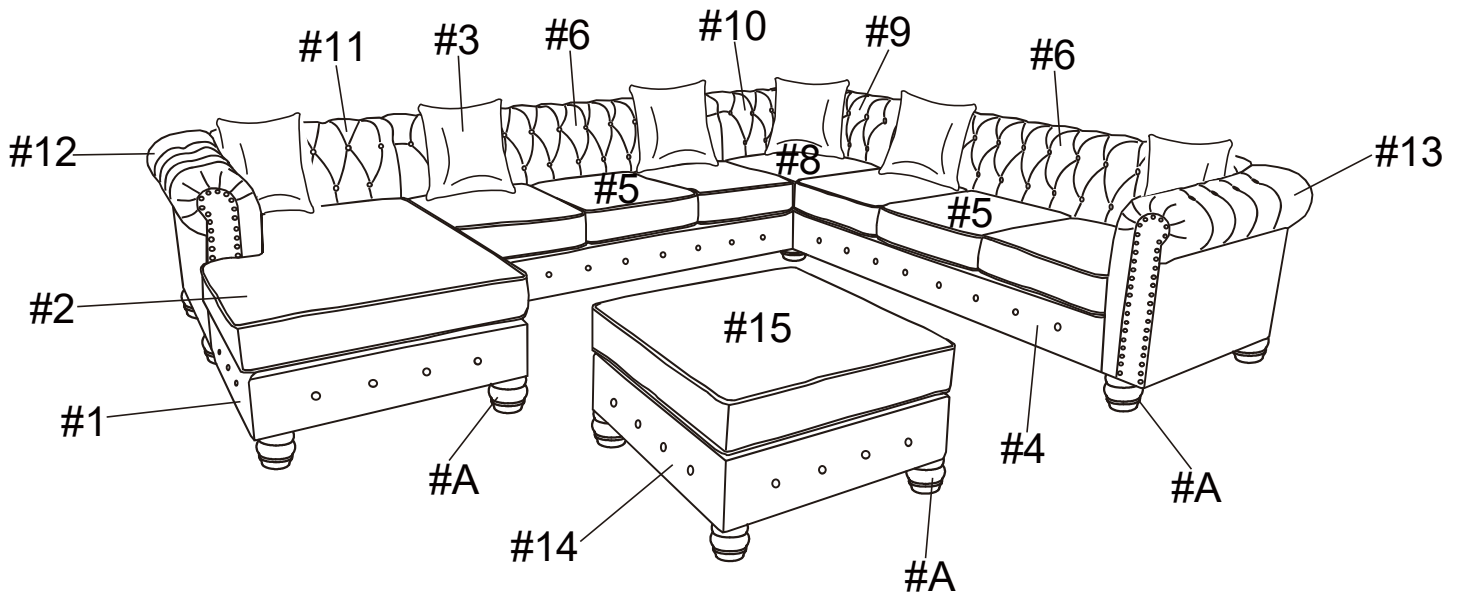

PARTS

#1 1PC

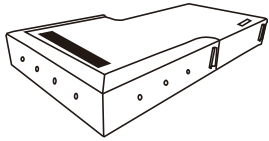

Chaise seat frame

#2 1PC



Chaise cushion

#3 6PCS



Pillow

#4 2PCS



Sofa seat frame

#5 6PCS

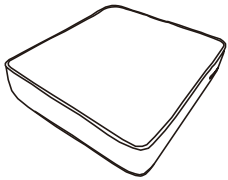

Sofa cushion

#6 2PCS

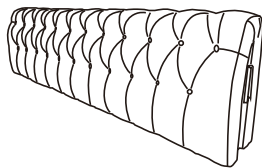

Sofa backrest

#7 1PC

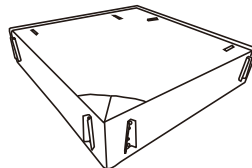

Corner seat frame

#8 1PC

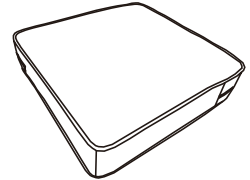

Corner cushion

#9 1PC

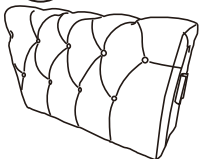

Corner right backrest

#10 1PC

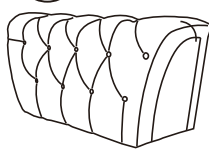

Corner left backrest

#11 1PC

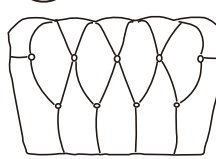

Chaise backrest

#12 1PC

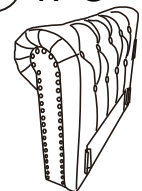

Left arm

#13 1PC

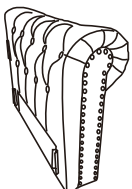

Right arm

#14 1PC



Ottoman seat frame

#15 1PC

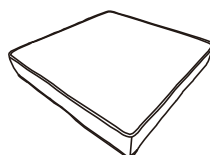

Ottoman cushion

#A 15PCS



Leg

#B 5PCS



Connection

ASSEMBLY INSTRUCTION

STEP 1:

Assemble the 4 parts #A(Leg) to parts #12(Left arm) and #13(Right arm) respectively.

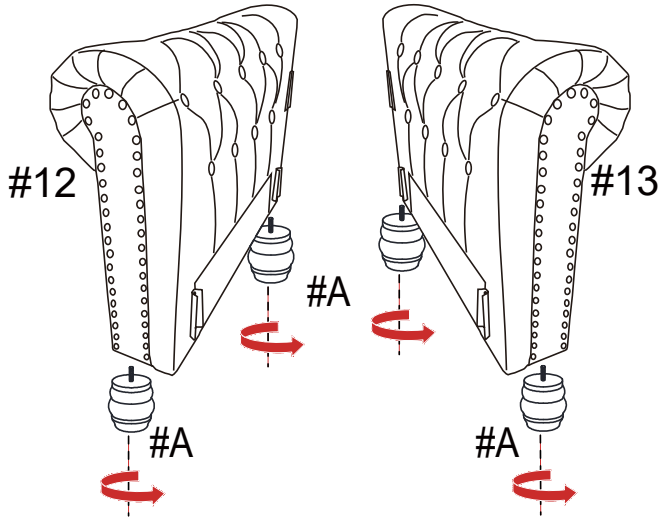

STEP 2:

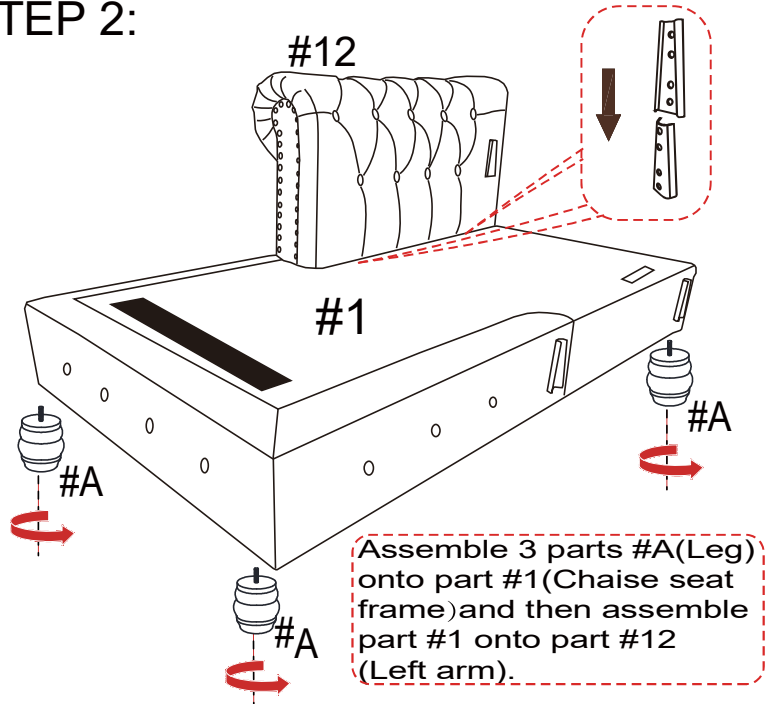

STEP 3:

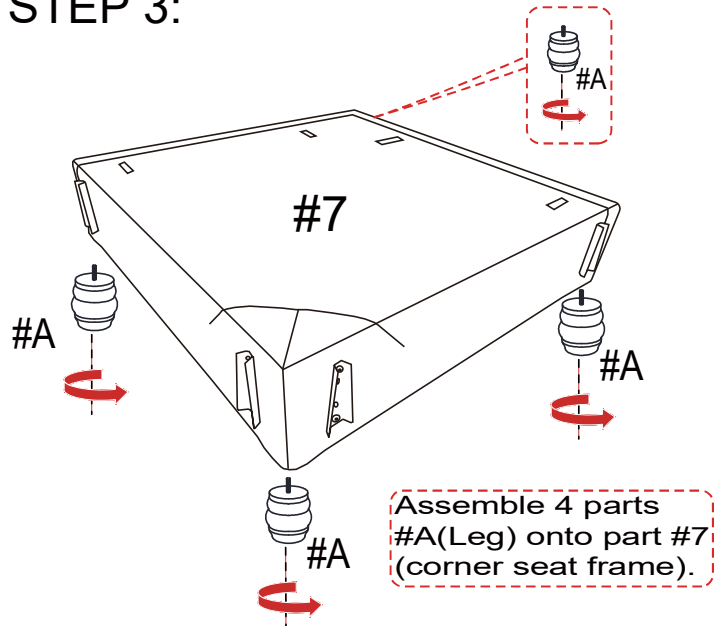

STEP 4:

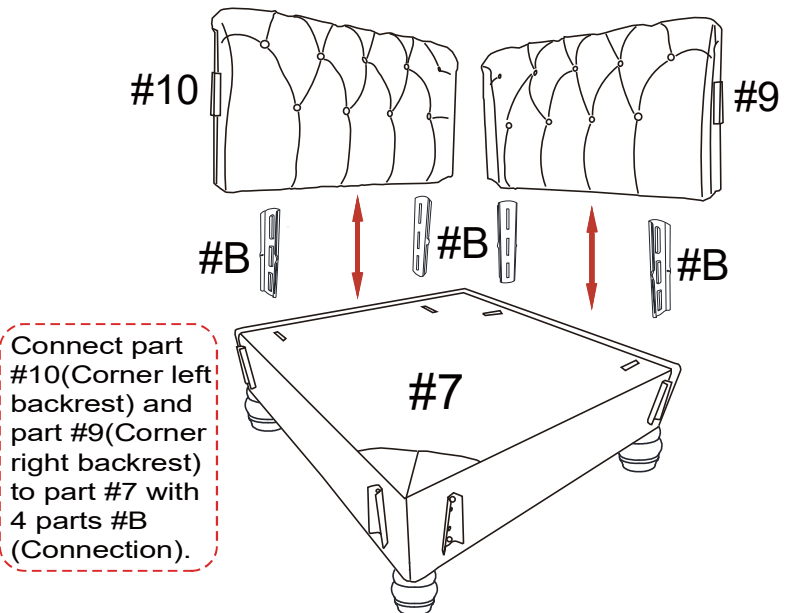

STEP 5:

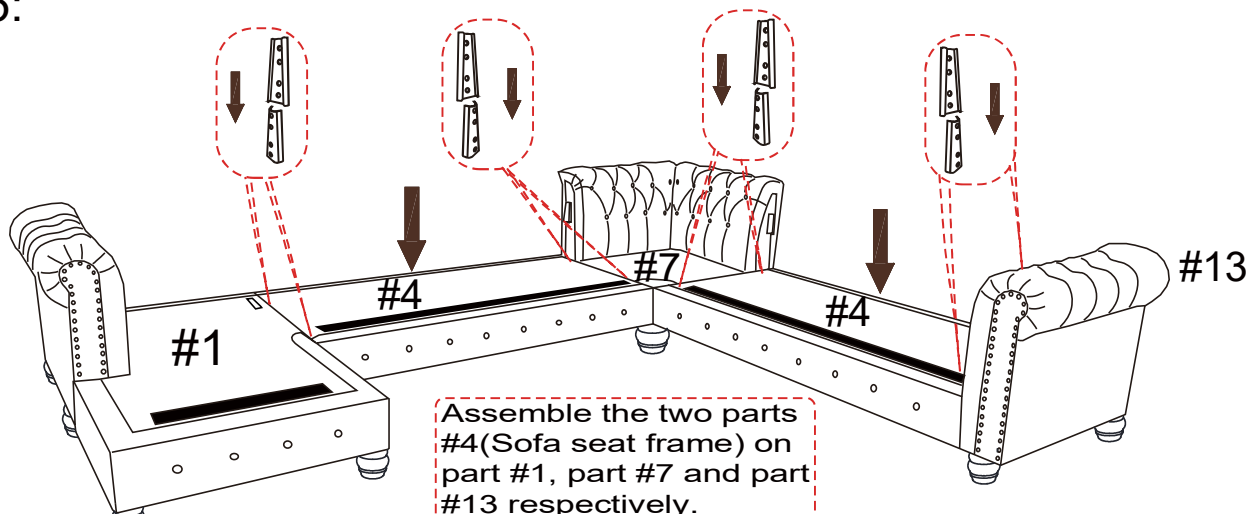

ASSEMBLY INSTRUCTION

STEP 6:

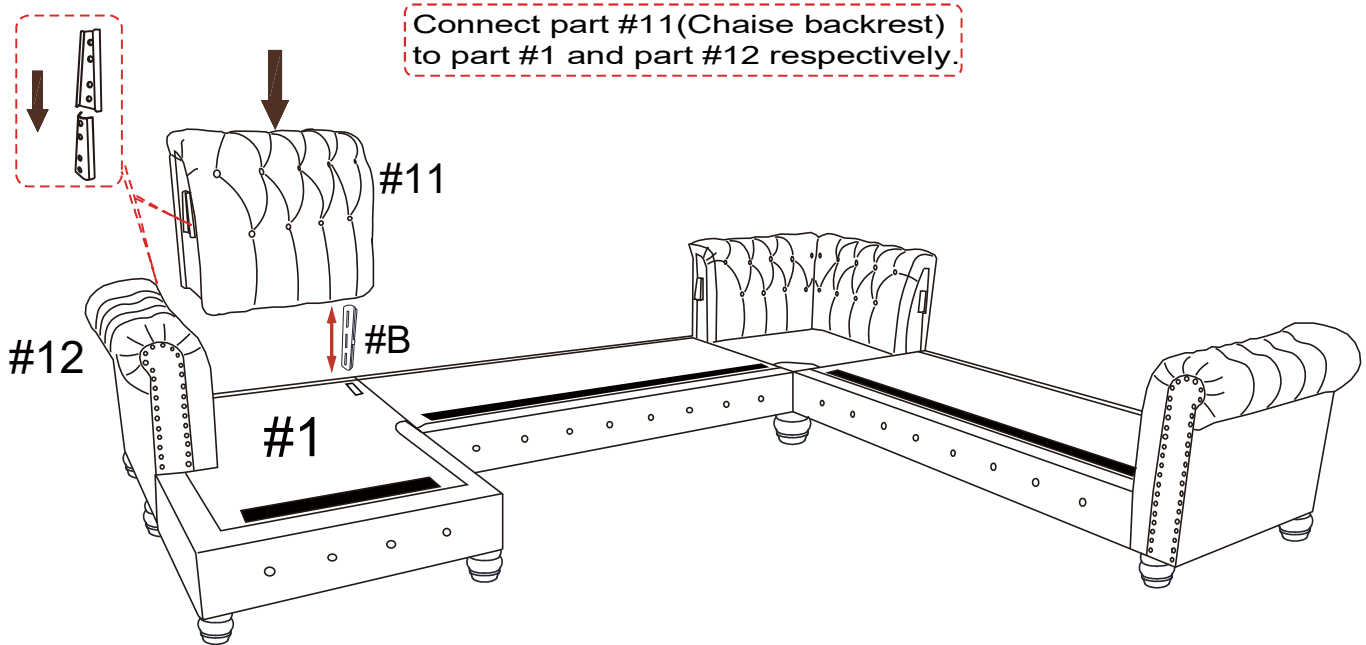

STEP 7:

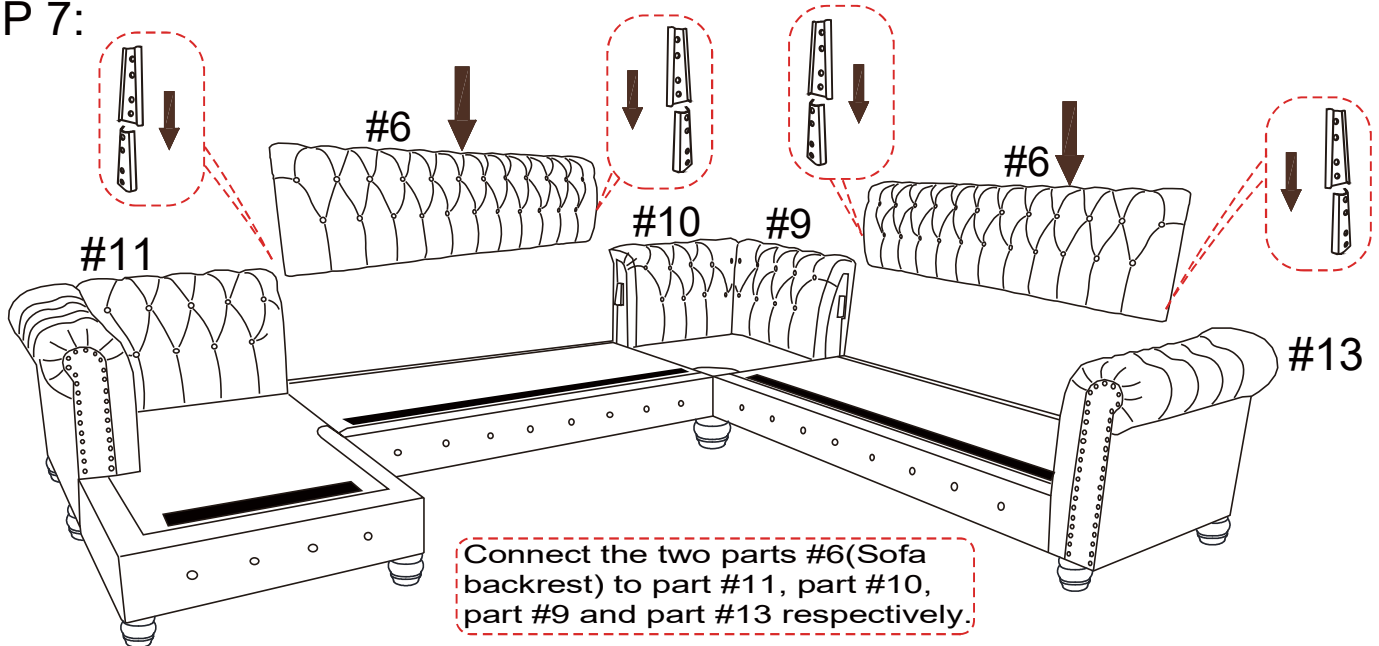

STEP 8:

Place parts #2 (Chaise cushion), #5 (Sofa cushion) and #8 (Corner cushion).

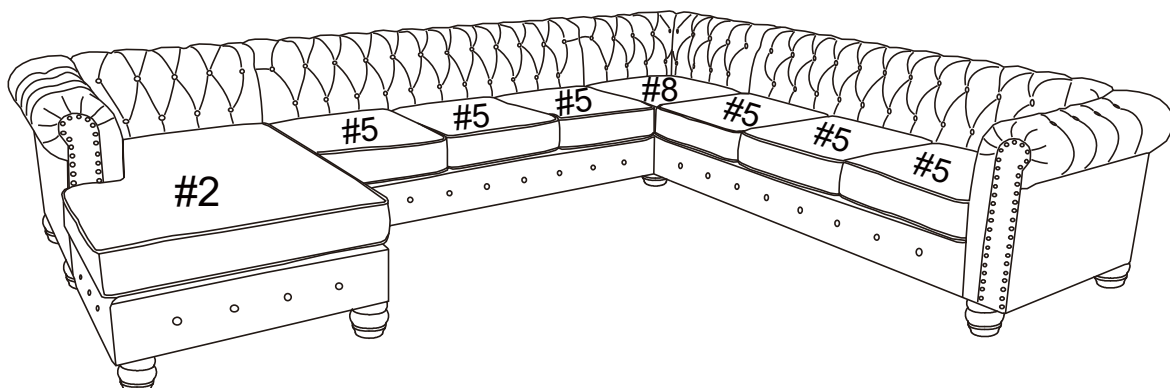

ASSEMBLY INSTRUCTION

STEP 9:

Place part #3(Pillow) in place.

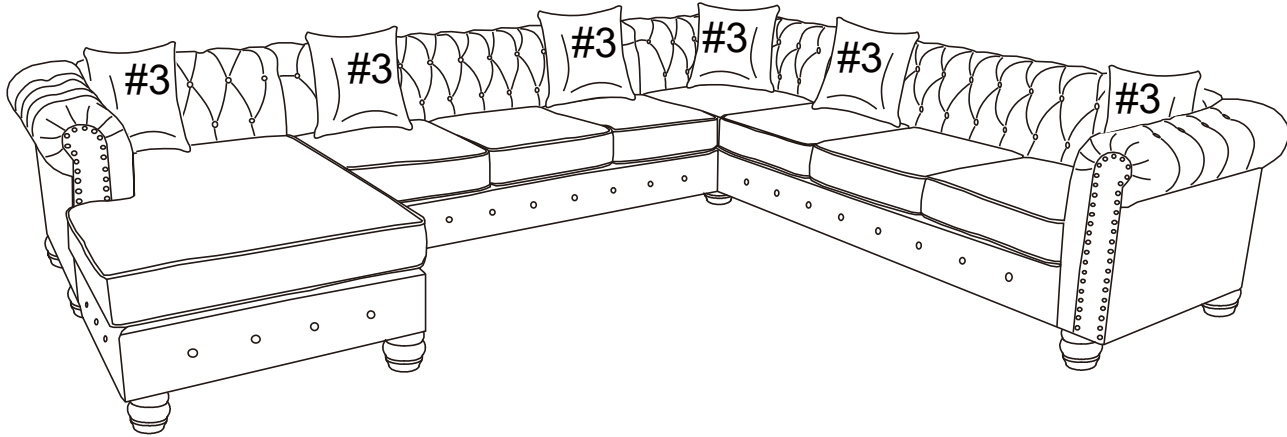

STEP 10:

Assemble 4 parts #A(Leg) onto part #14(Ottoman).

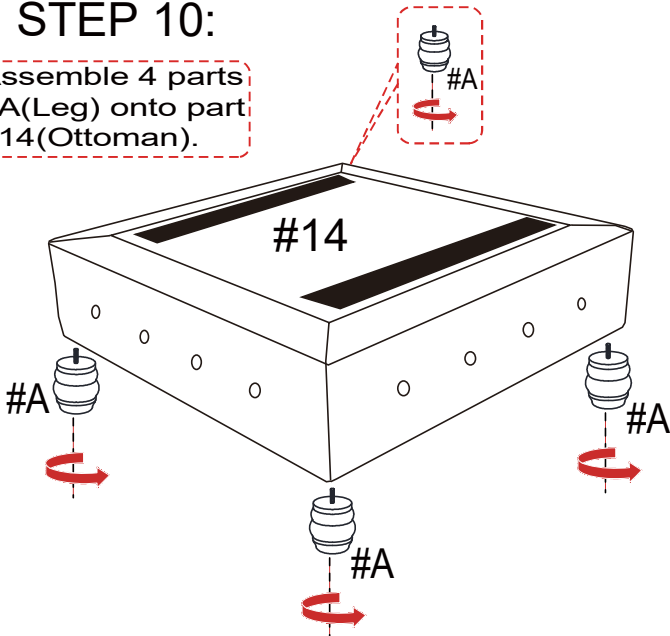

STEP 11:

Place part #15(Ottoman cushion) on part #14.

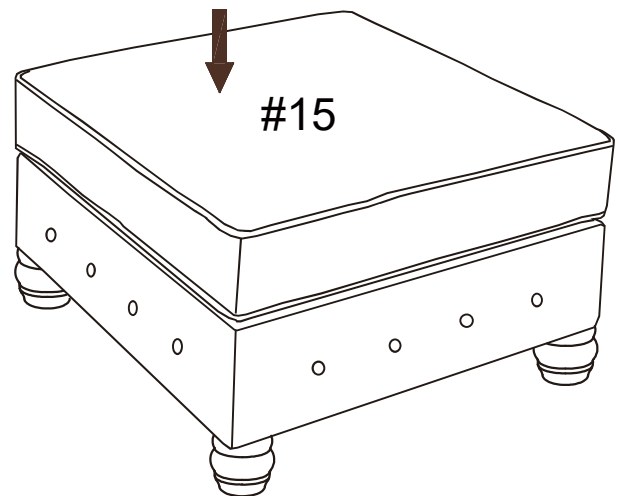

STEP 12:

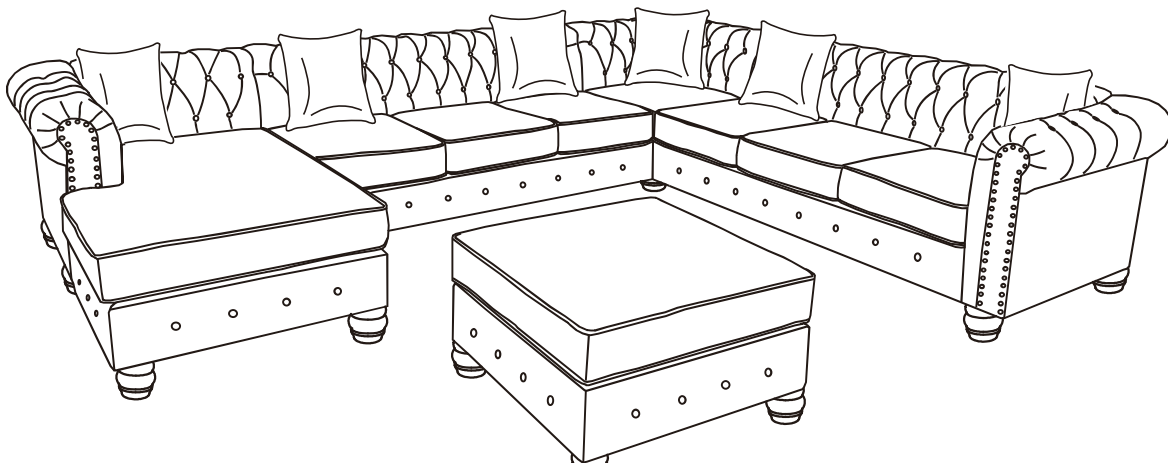

ASSEMBLY COMPLETED



Please ensure the furniture rests on an even and flat surface. If the product wobbles or feels loose, double-check all bolts and/or screws are properly tightened and secured.

Keep this handy!

Please retain this instruction manual and any order-related information for future reference.

Lift, don't drag!

To avoid damage to product please always LIFT the product