

Installation Instructions

Product Parts		
Number	Sketch Drawing	Quantity
1		1
2		1
3		1
4		1
5		2

Hardware Accessories		
Number	Sketch Drawing	Quantity
A		1
B		8
C		8
D		8
E		4

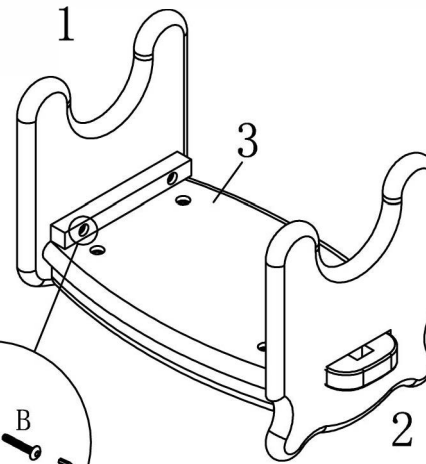

2. Turn the product over. Thread the M6 spring washer and M6 flat washer onto the M6*30mm bolt in sequence, insert it into the corresponding hole on Component 3, and use a No. 4 hex key to assist in the installation to secure Components 1, 2 and 3 firmly.

RF-DZ1327/1328/1329
RF-DZ1355/1356/1357

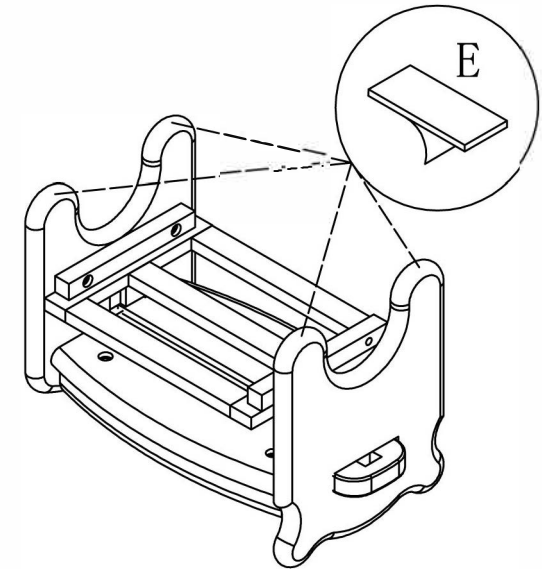

4. Stick the felt pads onto the bottom of the four legs.

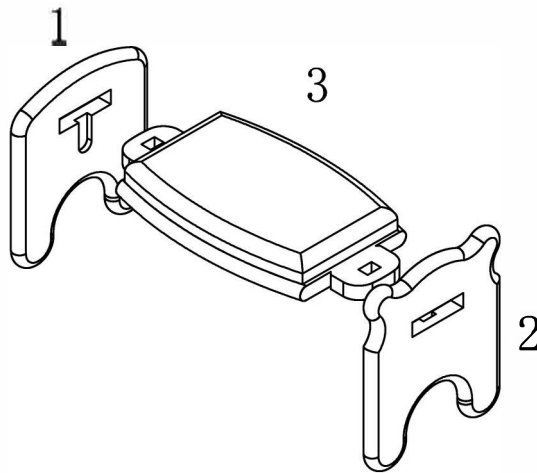

1. Align the clamping slots on Component 1 and Component 2 with the corresponding tenons on both ends of Component 3 respectively, and then gently snap them onto the tenons.

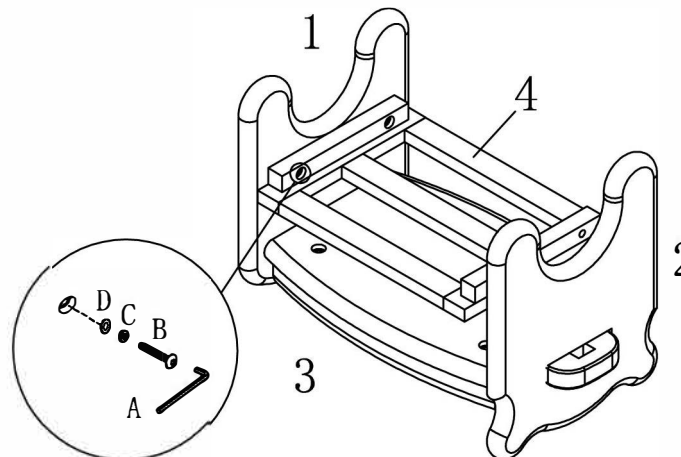

3. Align the holes on both ends of Component 4 with the corresponding holes on Component 1 and Component 2 respectively. Thread the M6 spring washer and M6 flat washer onto the M6*30mm bolt in sequence, insert it into the corresponding hole on Component 3, and use a No. 4 hex key to assist in fastening the assembly.

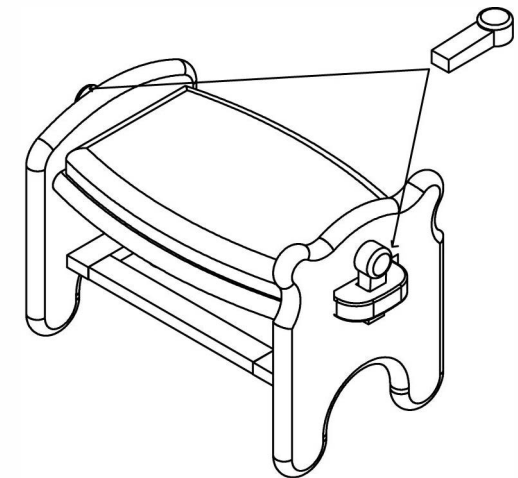

5. Insert the No. 5 fixing pin into the corresponding hole. Check that all bolts and pins are fully installed and tightened. Installation is complete.