

**ASSEMBLY INSTRUCTIONS**  
**COASTER FINE FURNITURE**

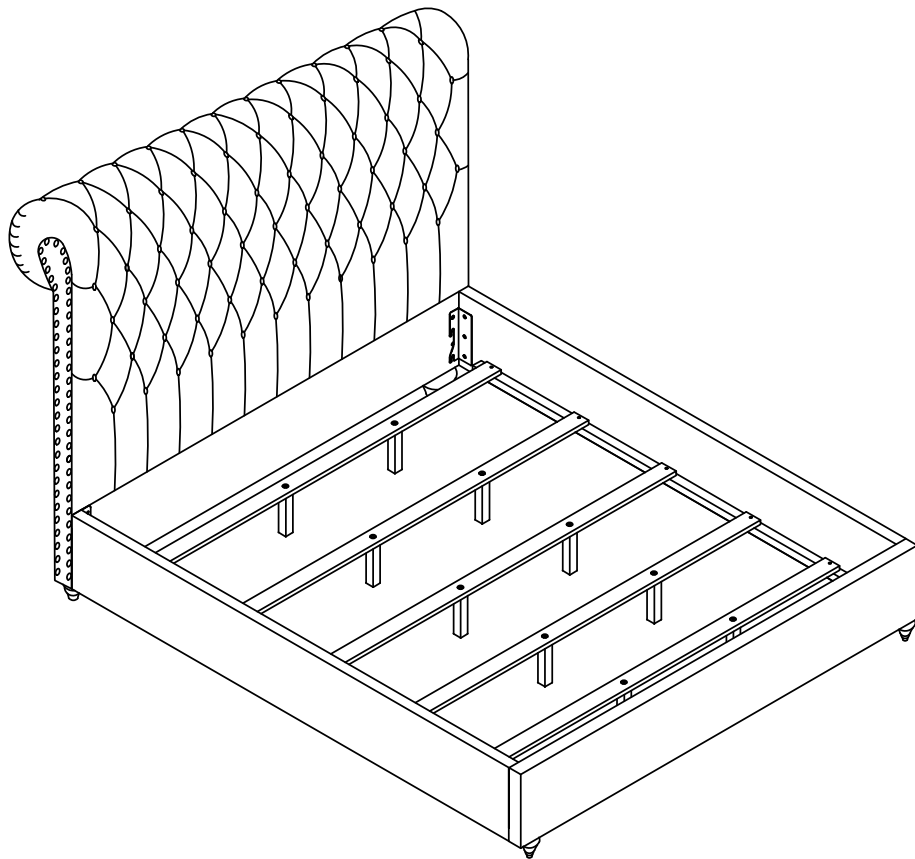

*Fine Furniture for every stage of life*

**300525KW(B1&B2)**  
***California King Bed***

# ITEM: 300525KW(B1&B2)



## ASSEMBLY INSTRUCTIONS

### ASSEMBLY TIPS:

1. Remove hardware from box and sort by size.
2. Please check to see that all hardware and parts are present prior to start of assembly.
3. Please follow attached instructions in the same sequence as numbered to assure fast & easy assembly.

### WARNING!



1. Don't attempt to repair or modify parts that are broken or defective. Please contact the store immediately.
2. This product is for home use only and not intended for commercial establishments.

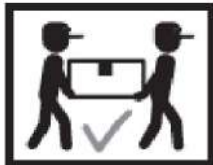

ASSEMBLY TIME

30 MINUTES

## PARTS IDENTIFICATION

### B1(BOX1)

AV HEADBOARD PANEL

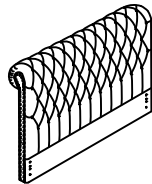

1PC

BV HEADBOARD LEG



2PCS

### B2(BOX2)

CV FOOTBOARD LEG



2PCS

DV BED RAIL



2PCS

EV FOOTBOARD PANEL

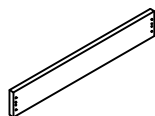

1PC

FV CENTER RAIL SUPPORT WITH LEVELER

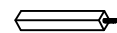

10PCS

GV BED SLAT

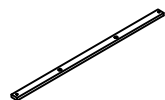

5PCS

FBV 300525KW(B2) FROM BOX2 FOOTBOARD COMPLETE

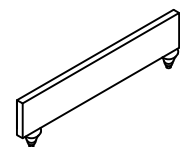

1PC

HBV 300525KW(B1) FROM BOX1 HEADBOARD COMPLETE

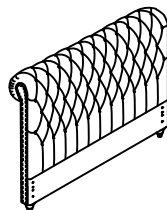

1PC

# ITEM: 300525KW(B1&B2)

## ASSEMBLY INSTRUCTIONS

### ASSEMBLY TIPS:

1. Remove hardware from box and sort by size.
2. Please check to see that all hardware and parts are present prior to start of assembly.
3. Please follow attached instructions in the same sequence as numbered to assure fast & easy assembly.









### WARNING!

1. Don't attempt to repair or modify parts that are broken or defective. Please contact the store immediately.
2. This product is for home use only and not intended for commercial establishments.

## HARDWARE IDENTIFICATION

### Z-B2(BOX2)-HARDWARE PACK IS LOCATED IN 300525KW(B2)

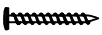
1	<b>ALLEN WRENCH</b> (5MM-RBW)		1PC	2	<b>BOLT</b> ( Ø 5/16 "X32mm-RBW )		24PCS
3	<b>HEADBOARD CORNER BRACKET -RIGHT</b> (200mmX60mmX40mmX2mm-RBW)		2PCS	4	<b>HEADBOARD CORNER BRACKET -LEFT</b> (200mmX60mmX40mmX2mm-RBW)		2PCS
5	<b>LOCK WASHER</b> ( Ø 5/16 "-RBW )		24PCS	6	<b>FLAT WASHER</b> ( Ø 5/16 "-RBW )		24PCS
7	<b>FLAT HEAD SCREW</b> ( m4x30mm-RBW)		10PCS				

### NOTE:

Phillips head screw driver is required in the assembly process; however, manufacturer does not provide this item.

ITEM: **300525KW(B1&B2)**

**ASSEMBLY INSTRUCTIONS**

**STEP 1**

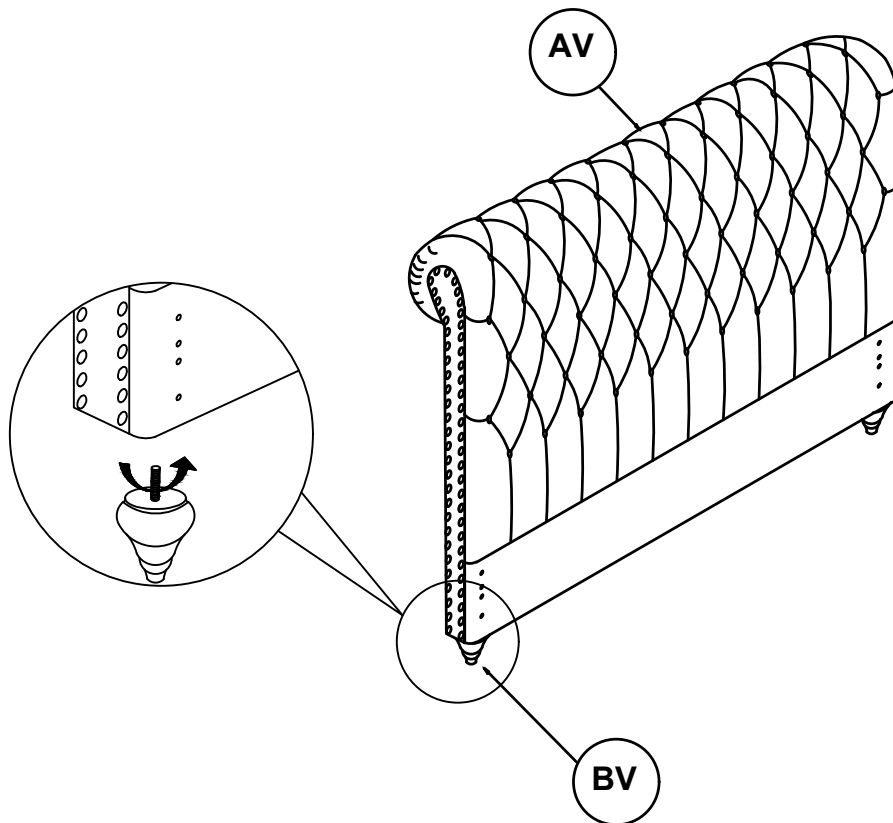

**STEP 2**

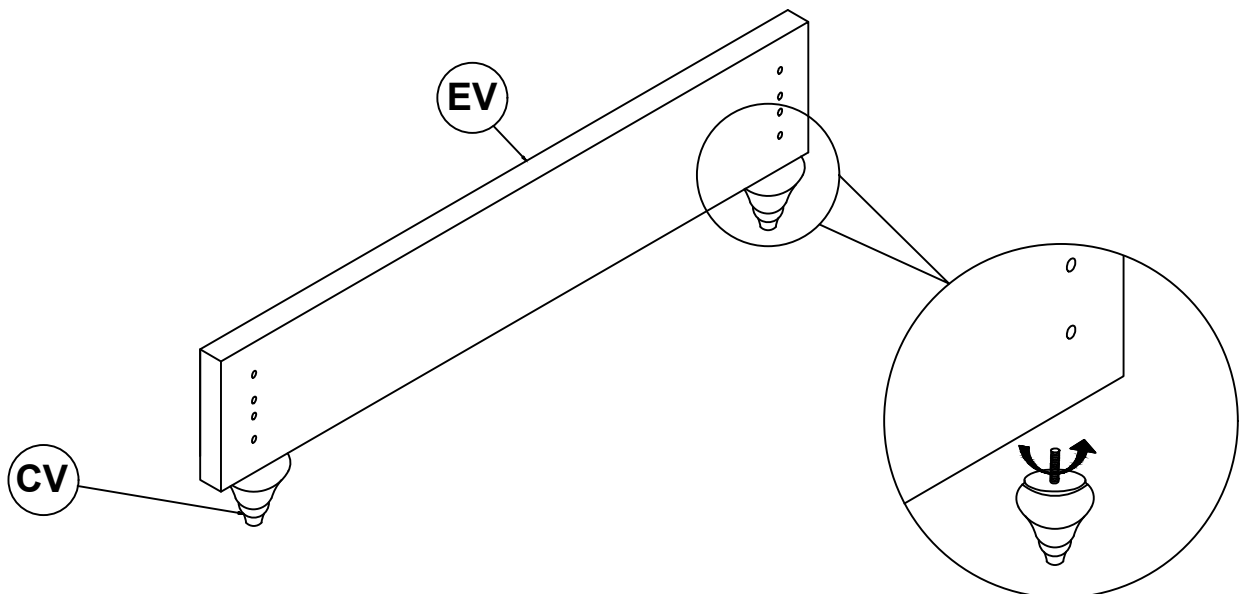

**ASSEMBLY INSTRUCTIONS**

**STEP 3**

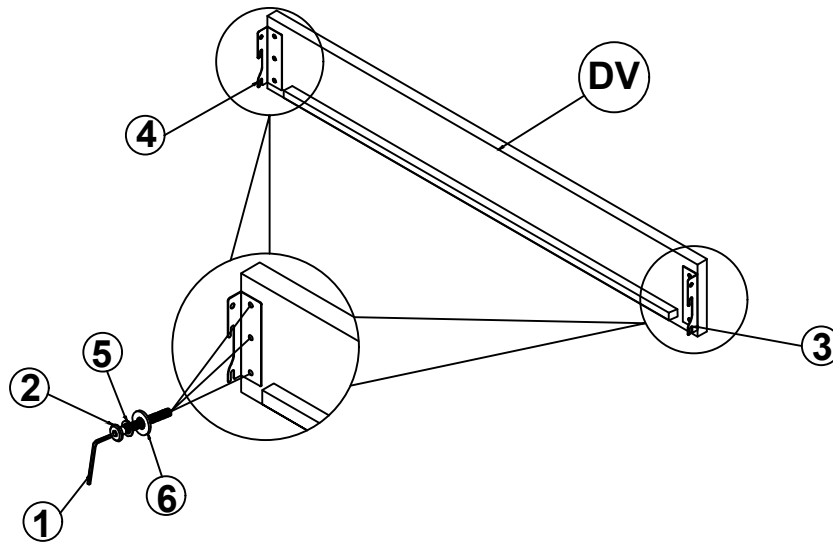

**STEP 4**

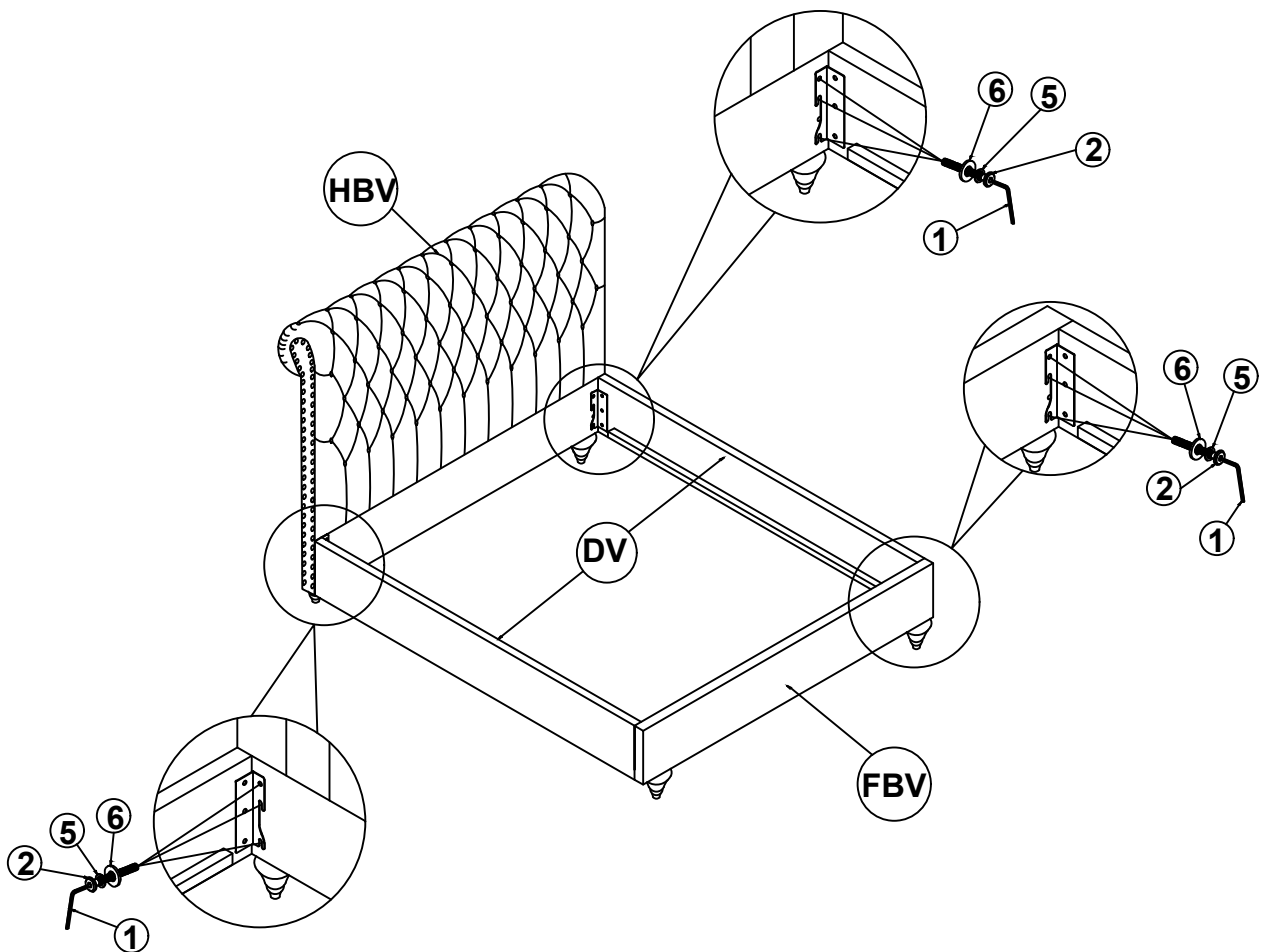

# ITEM: 300525KW(B1&B2)

## ASSEMBLY INSTRUCTIONS

### STEP 5

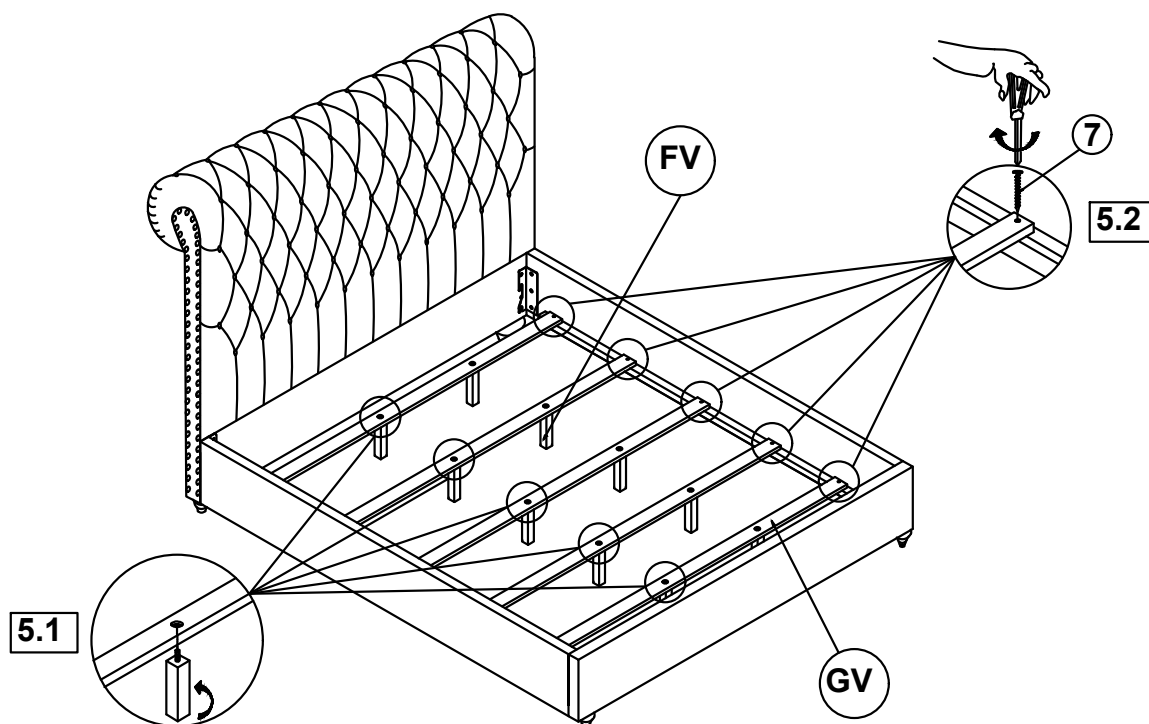

### STEP 6 COMPLETE

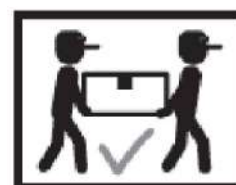
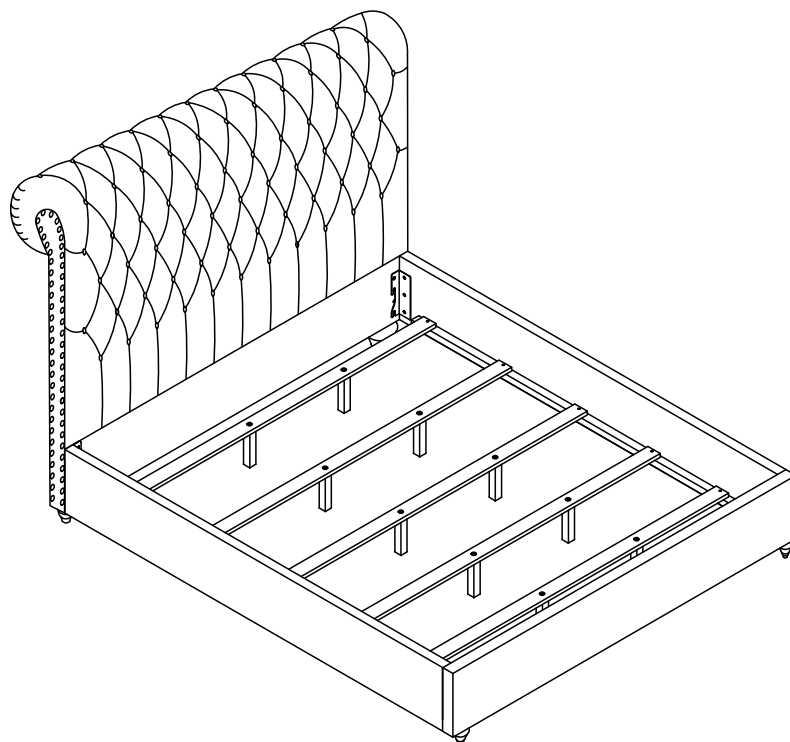

Inner Size: **73.25"W X 85.00"D**

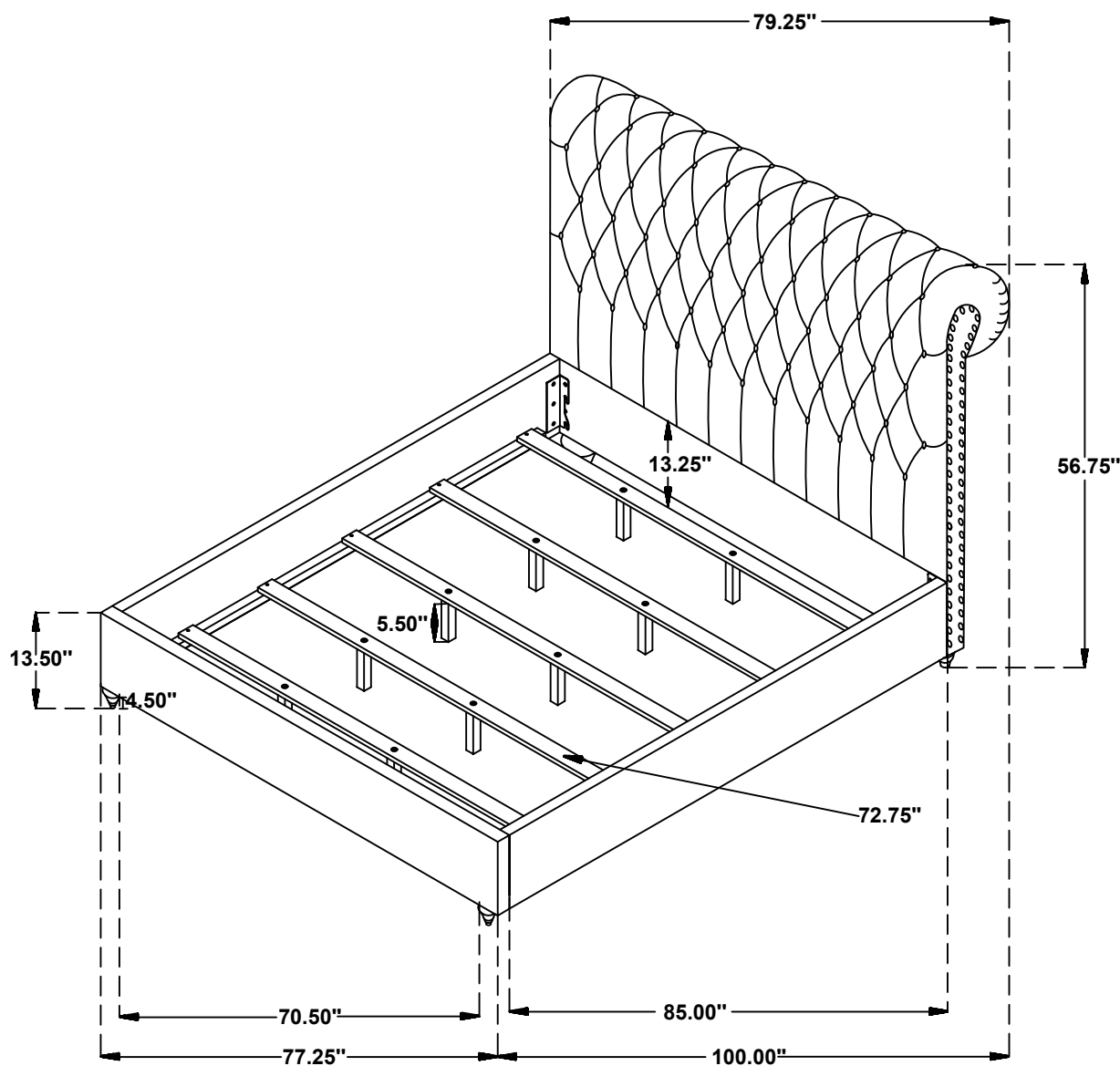

Note: Dimension tolerance  $\pm 5\%$