









ASSEMBLY INSTRUCTIONS

PART LIST

CODE	QTY
A	2
B	1
C	1
D	1
E	2
F	1
G	1
H	1
I	1
J	2
K	1
L	1
M	3
N	2

HARDWARE LIST

1		Wood Dowel $\phi 8 \times 30 \text{mm}$	26 pcs
2		Minifix Bolt	34 pcs
3		Minifix Cam	34 pcs
4		Screw $\phi 6.3 \times 50 \text{mm}$	8 pcs
5		PVC Nail With Pin	8 pcs
6		Shelf Support $\phi 5 \times 16 \text{mm}$	12 pcs
7		Allen Key M4	1 pc
8		Nail	28 pcs

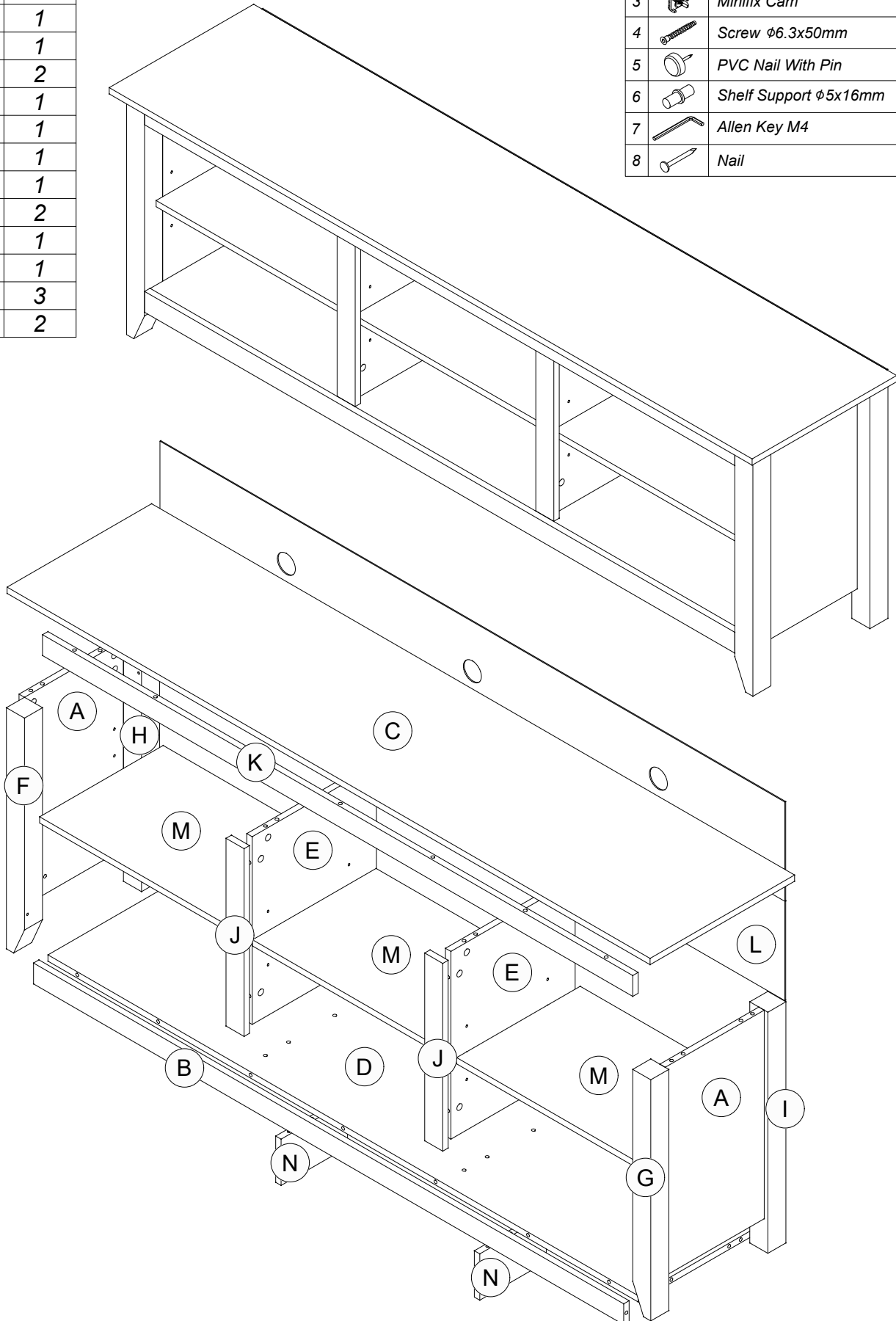

STEP 1

1  26 pcs

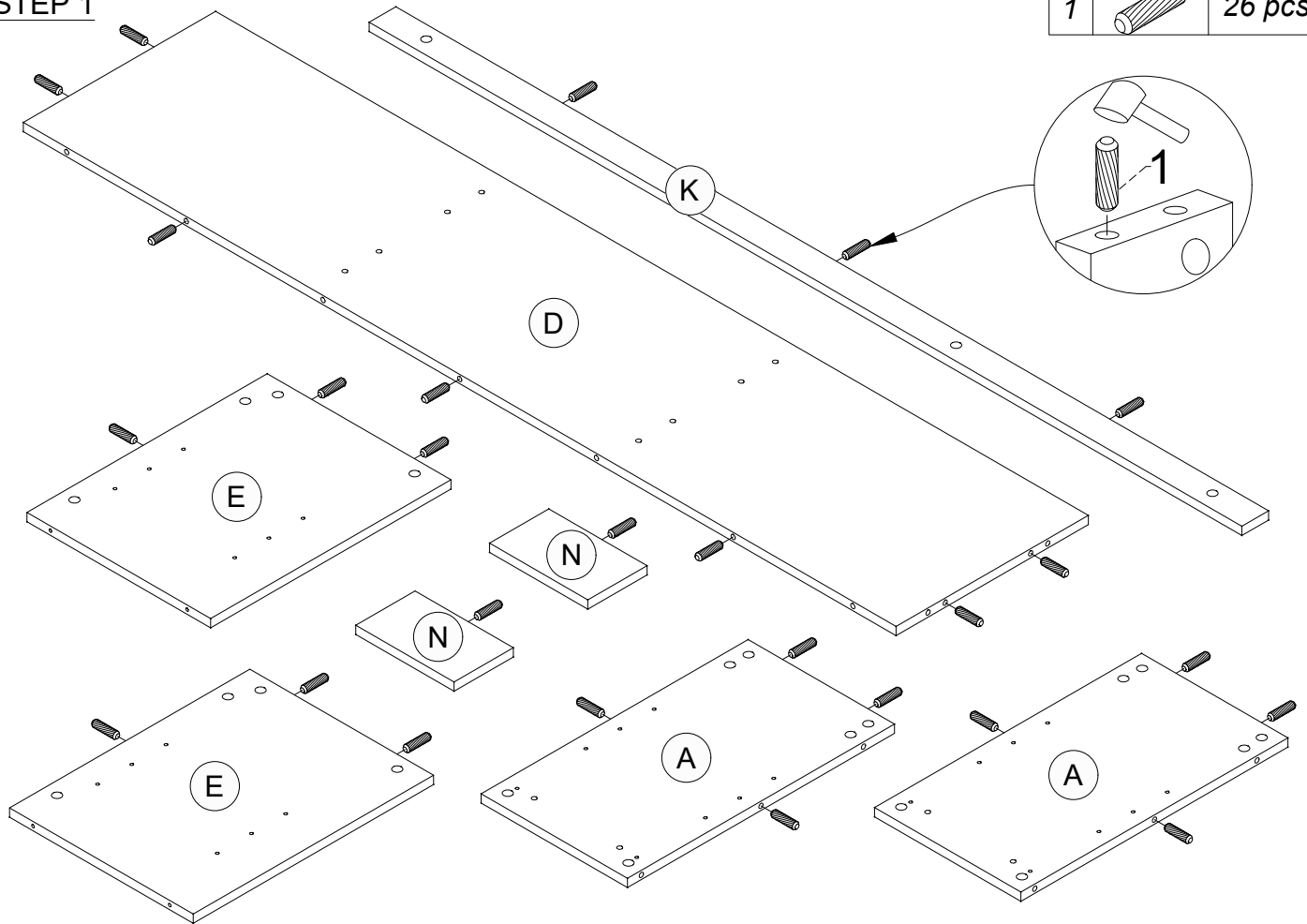

STEP 2

2  34 pcs

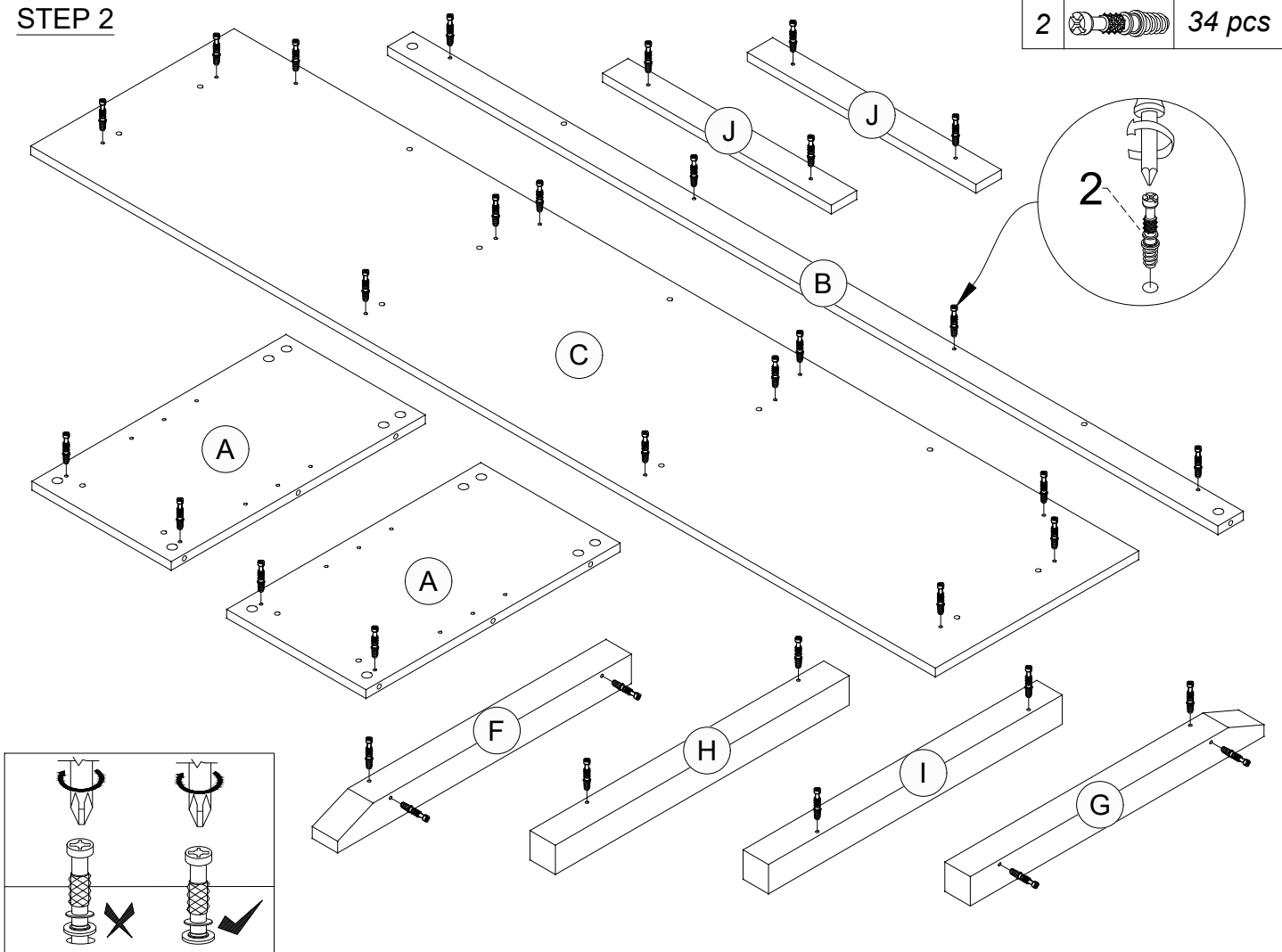

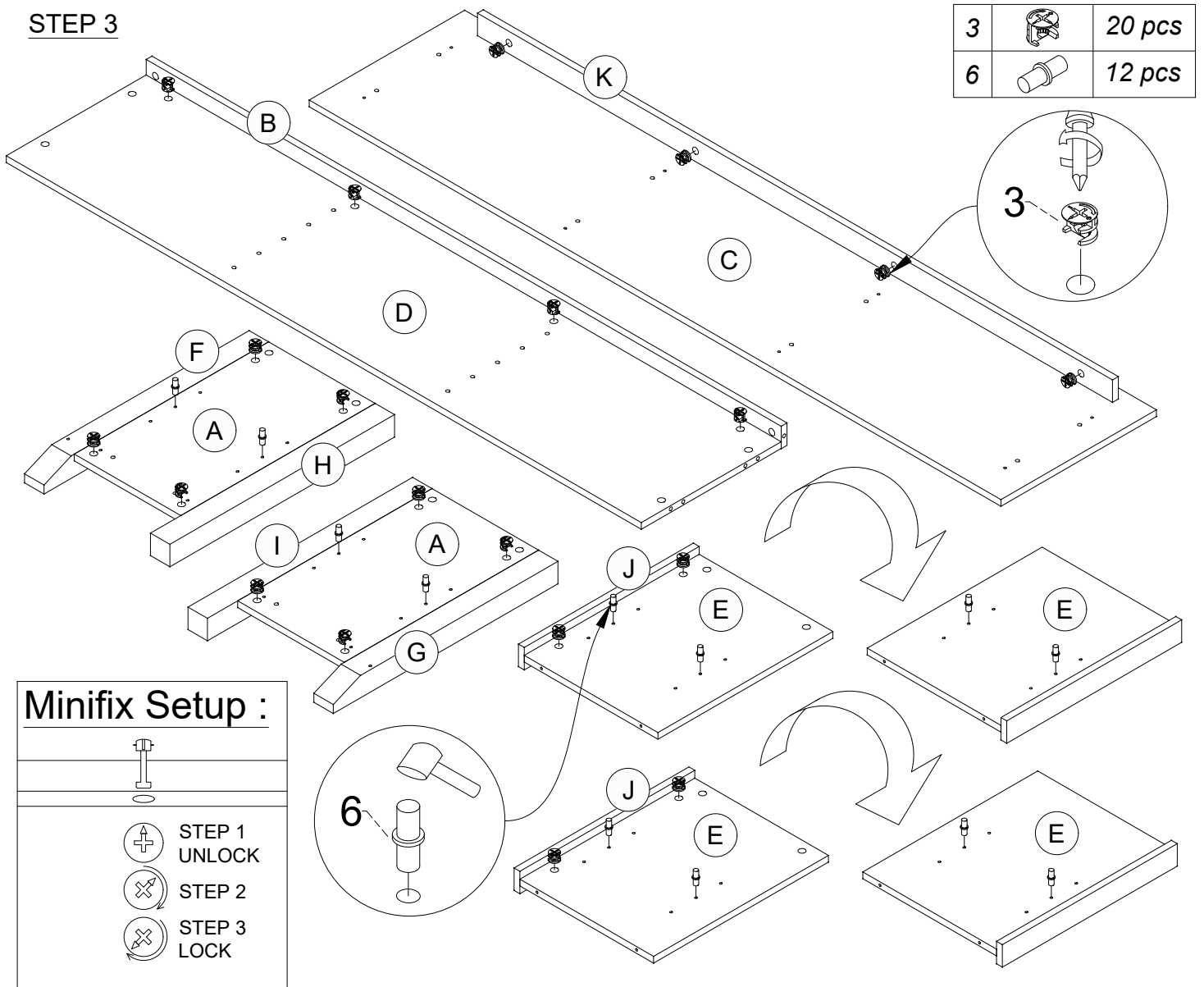

STEP 3

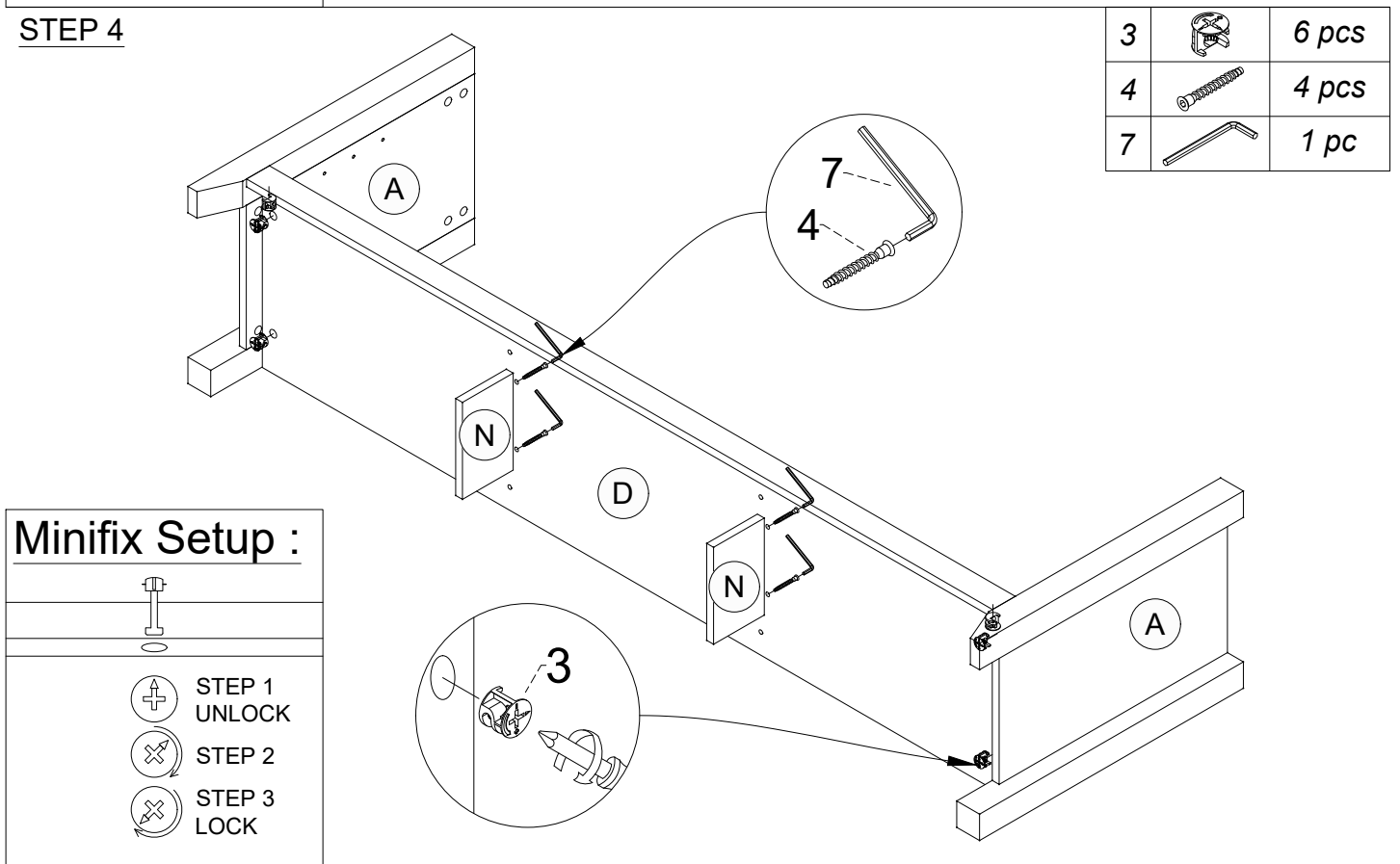

STEP 4



STEP 5

4		4 pcs
5		8 pcs
7		1 pc

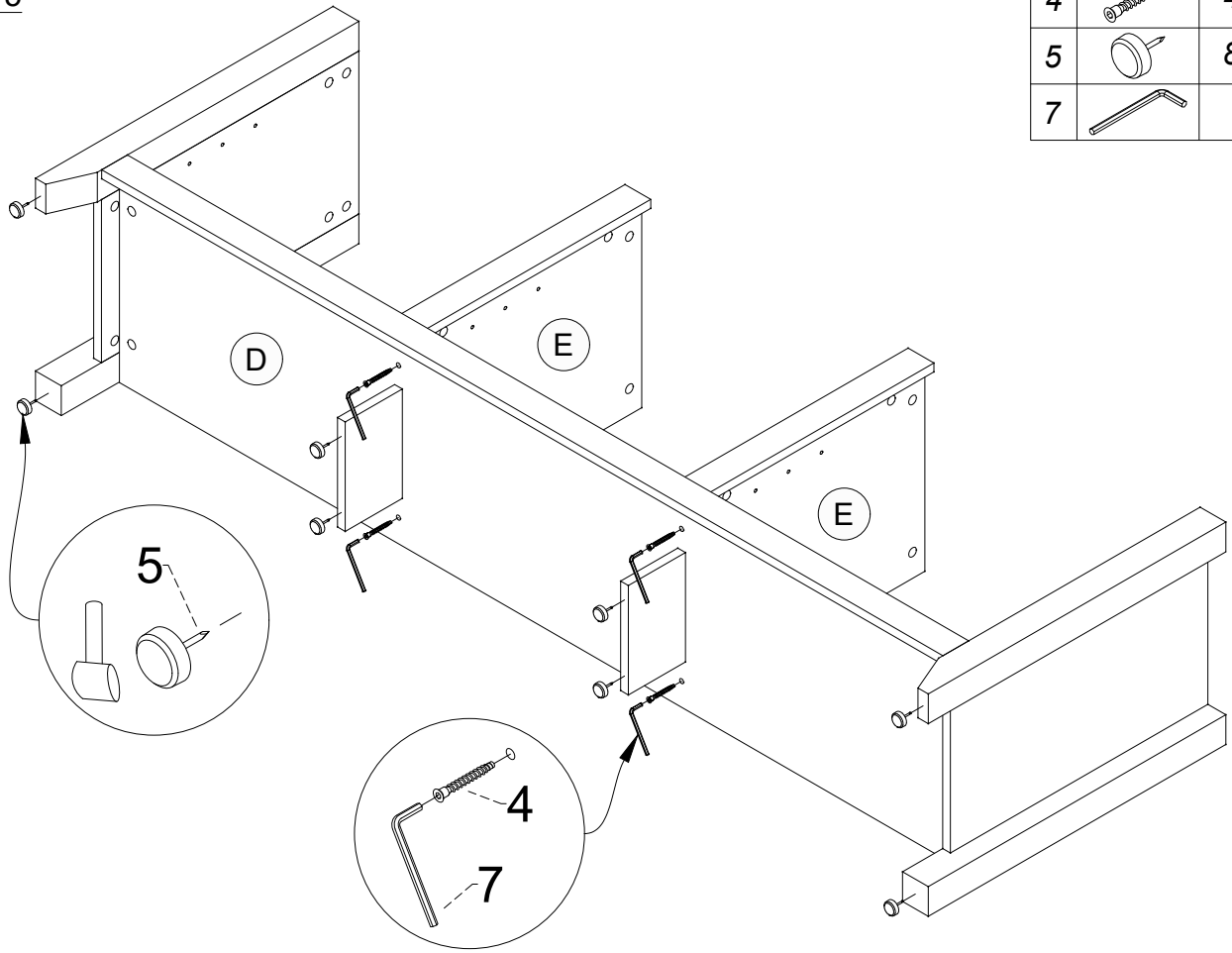

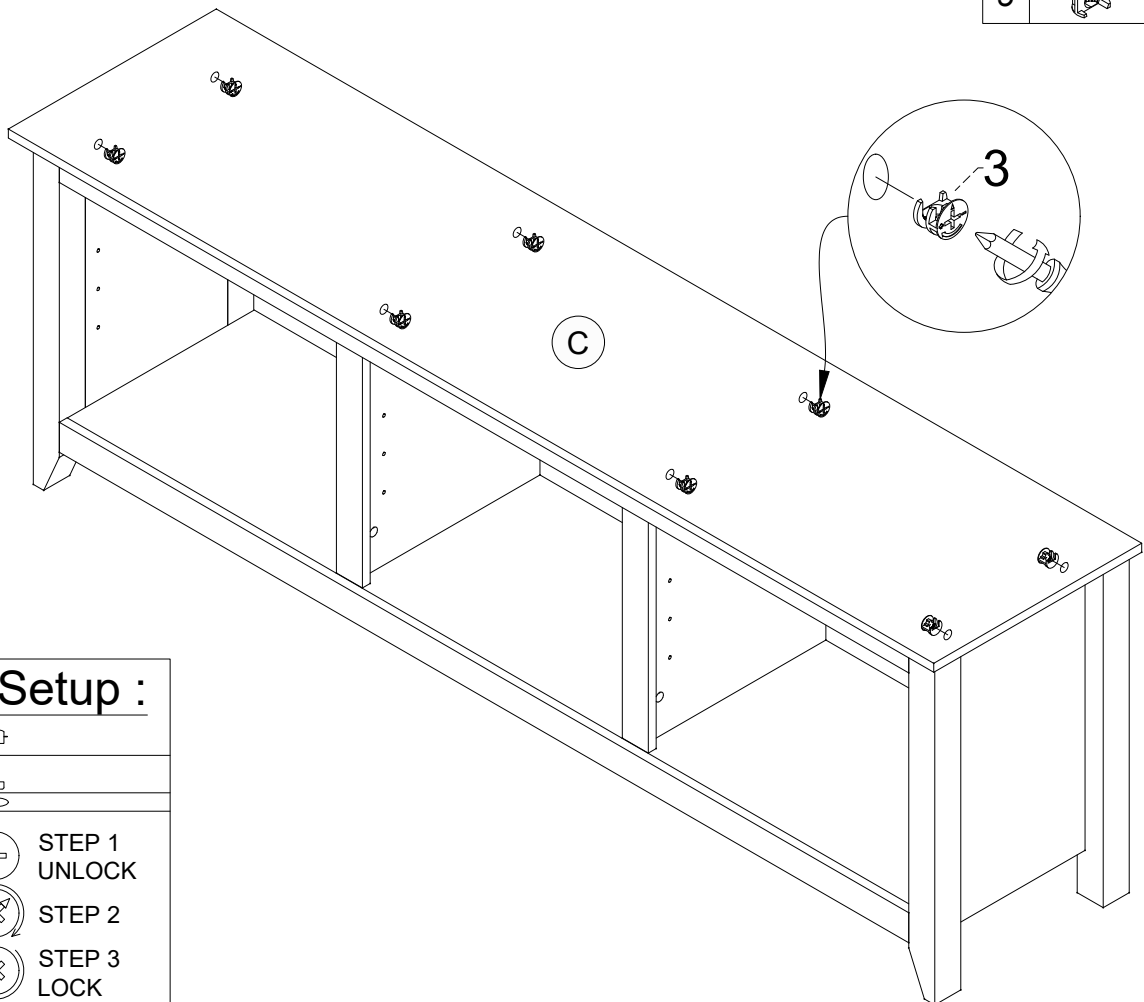

STEP 6

3		8 pcs
---	---	-------



Minifix Setup :



-  STEP 1
UNLOCK
-  STEP 2
-  STEP 3
LOCK

STEP 7

8		28 pcs
---	--	--------

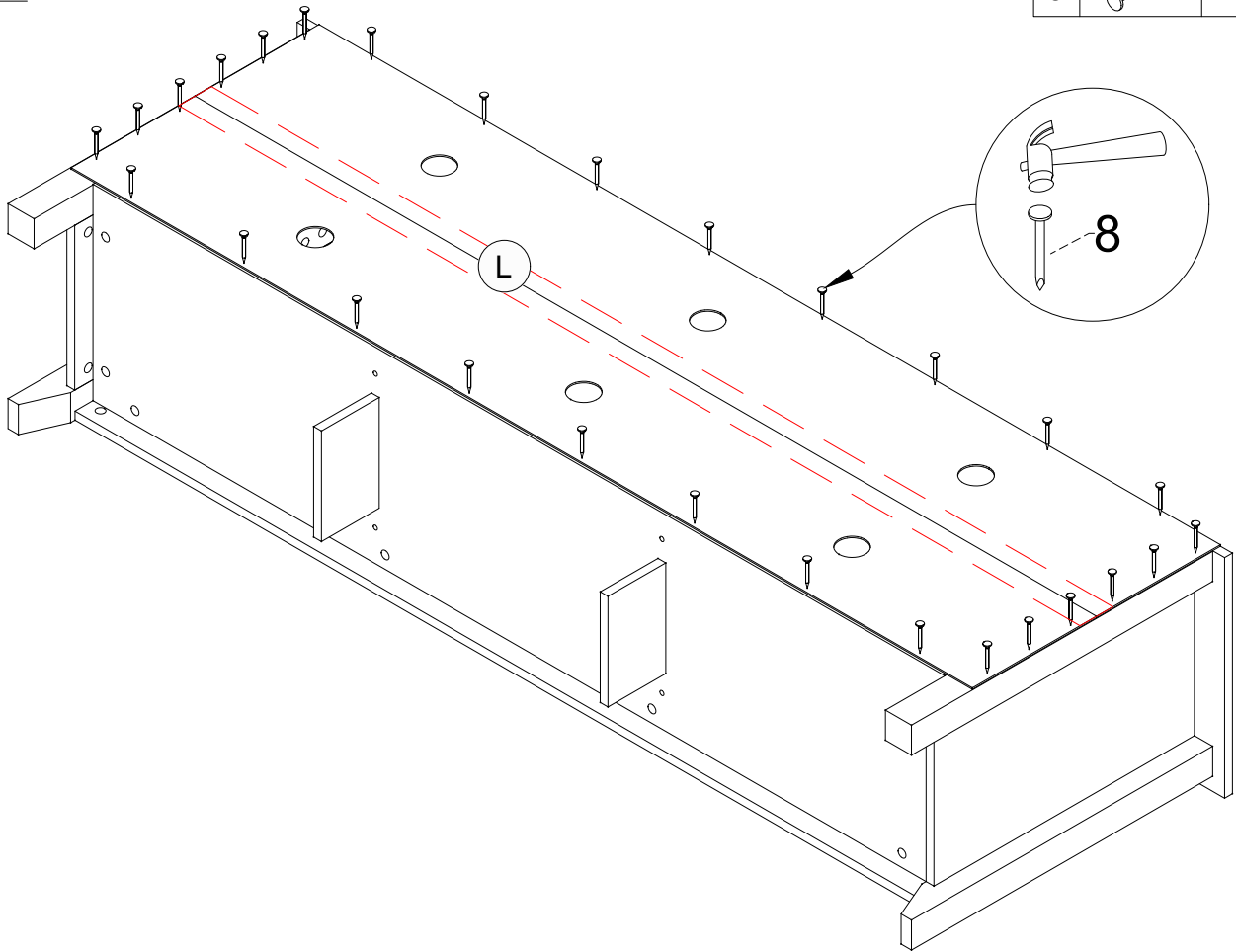

STEP 8

