

Assembly Instruction

4 - Tier Toolless Kitchen Storage Shelf Cart



Approx. 20 minutes







Recomm. 1 Person

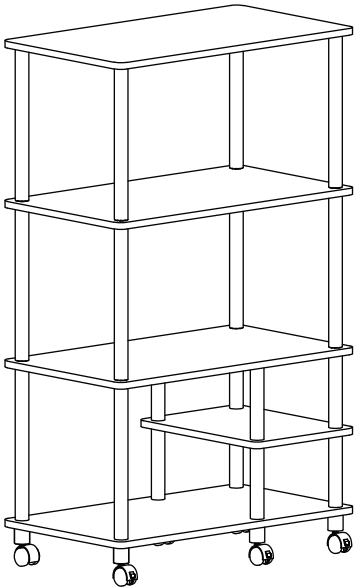

No Tools Required

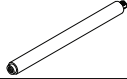

HARDWARE AND PART LIST

NO	HARDWARE LIST	QTY	NO	PART LIST	QTY
1	LONG ROUND POLE 	10 PCS	A	TOP PANEL	1 PC
2	SHORT ROUND POLE 	8 PCS	B	2ND SHELF PANEL	1 PC
3	PVC ROUND RING 	4 PCS	C	3RD SHELF PANEL	1 PC
4	ROUND LEG + CASTER WITH LOCK 	3 SETS	D	BOTTOM PANEL	1 PC
5	ROUND LEG + CASTER 	3 SETS	E	SMALL SHELF PANEL	1 PC

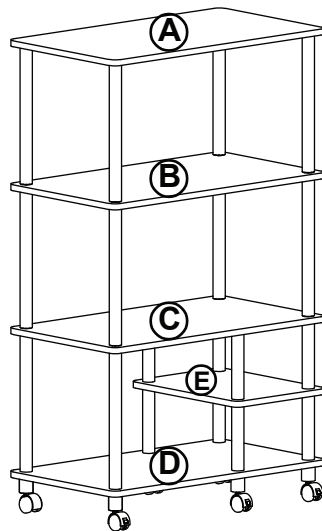

USEFUL HINTS BEFORE YOU START:

1. Read each step carefully before starting.
2. It is important that each step is performed in correct order to avoid difficulties.
3. Identify, sort and count the parts before assembly.
4. Assemble your furniture on packaging cardboard to prevent scratch or damage.
5. Clean the product with mild cleanser using soft damped cloth. Do not use harsh or abrasive cleanser.
6. Using incompatible hardware might cause damage to product.

Recommended Maximum Weight

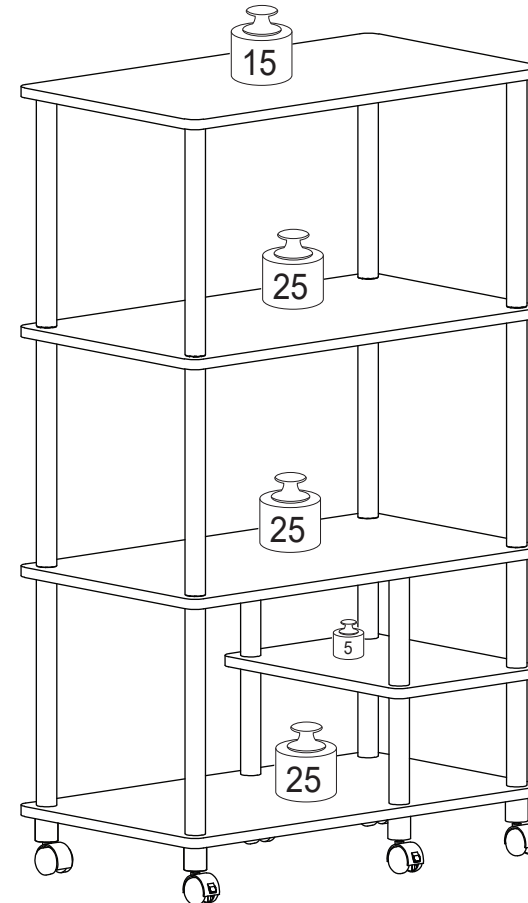

*Unit in Pound(lbs)

WARNING:

>This unit has been designed to support the maximum loads shown. Exceeding these load limits could cause sagging, instability, product collapse, and/or serious injury.

>DO NOT allow children to climb on unit.

>Put heavier items on lower shelves.

STEP 6

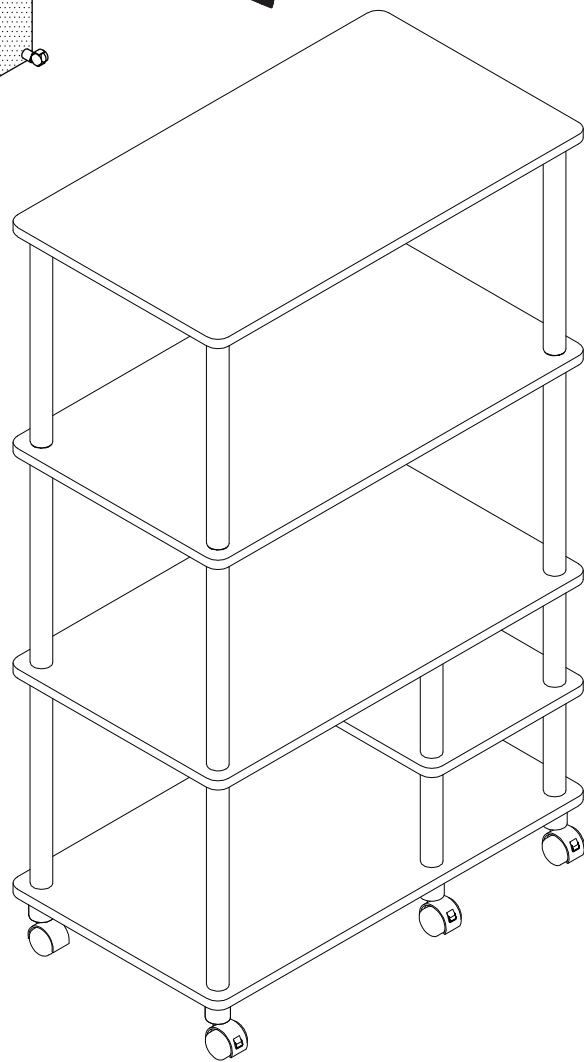
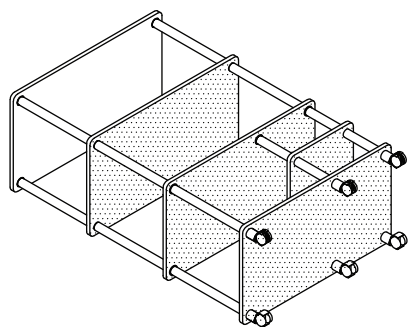

STEP 1

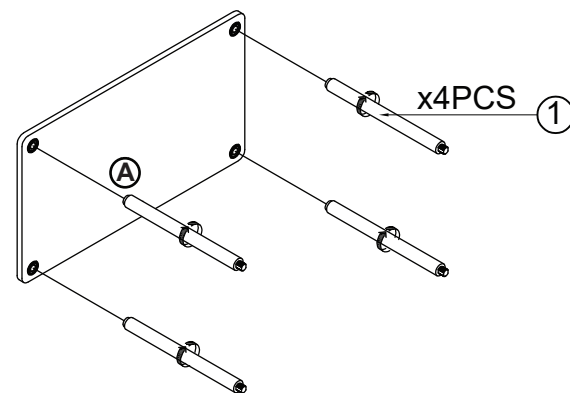

STEP 2

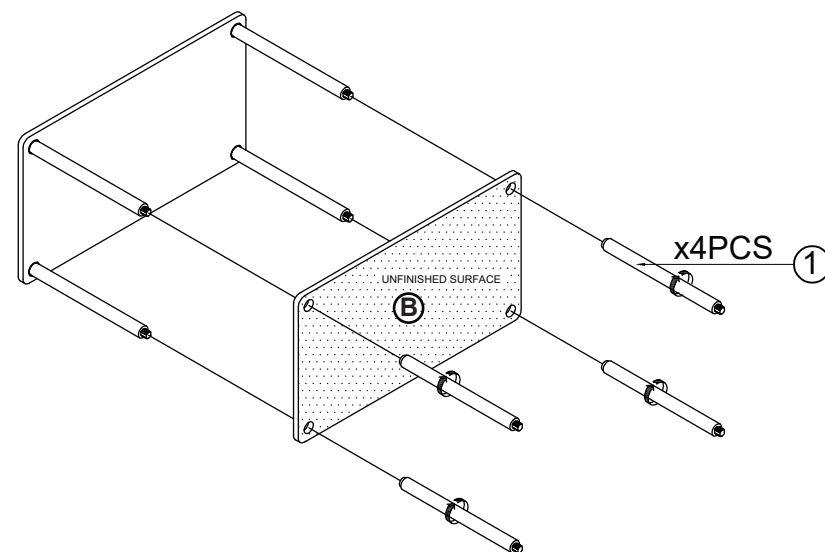

STEP 3

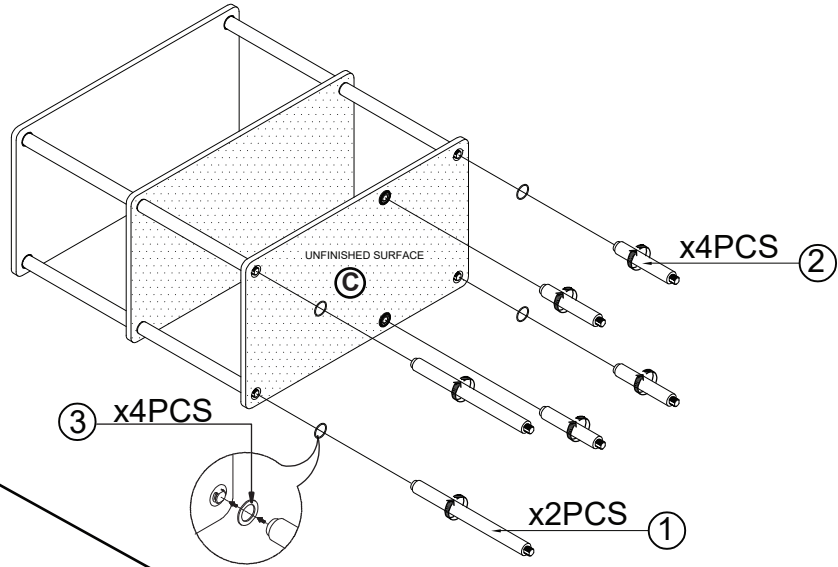

STEP 4

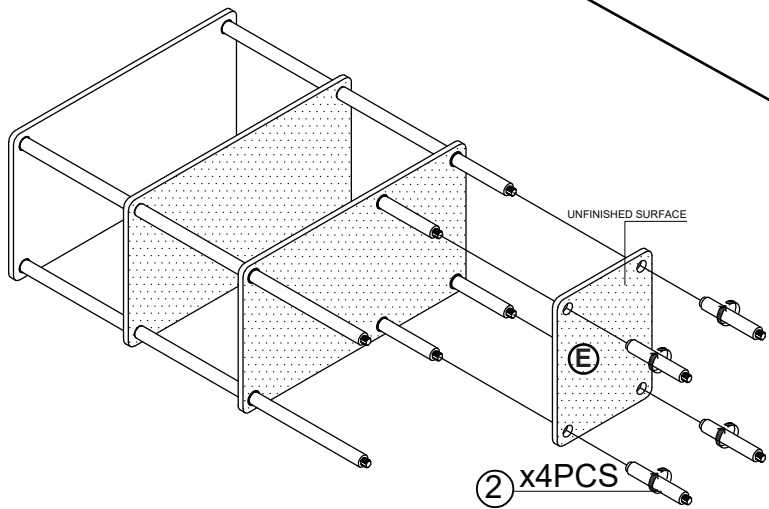

STEP 5

