



EXPANDABLE TV STAND CONSOLE

MODEL RTA-7050

ASSEMBLY INSTRUCTIONS

REV-WJ-6-8275-0824

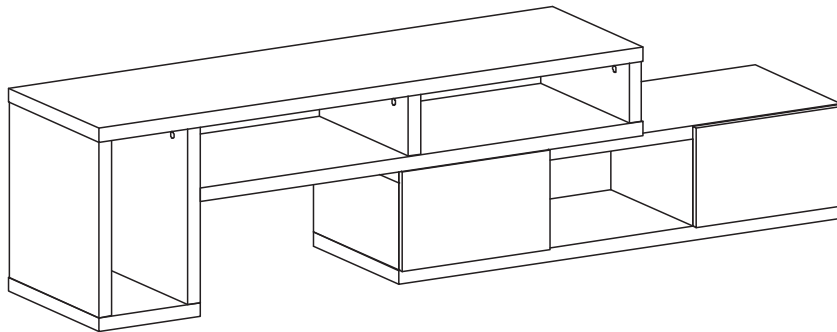

Thank you for purchasing our product



Do a quick inventory of all the parts and hardware listed below.



For Support, assembly questions & Replacement Parts within the 48 Contiguous United States:

Please email us at: support@rtaproducts.com



Replacement Parts for International Customers & **AK-HI-PR** orders: RTA Products will replace the part free of charge, while **the customer is responsible for shipping costs plus any International local taxes or duties.**

MAIN PARTS LIST

#1 Top panel for Upper Section

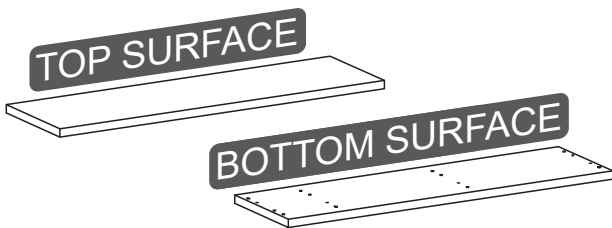

#2 Bottom panel for Upper Section

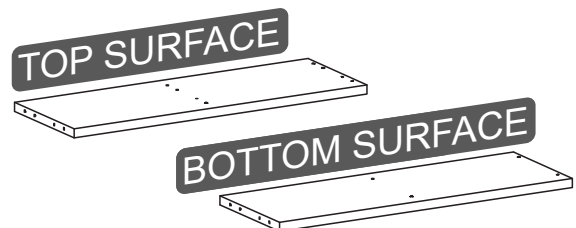

#3 Short vertical panel for Upper Section

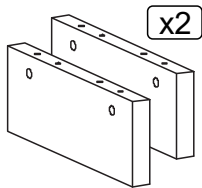

#4 Long exterior vertical panel for Upper Section

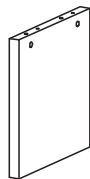

#5 Long interior vertical panel for Upper Section

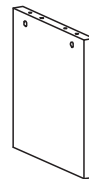

#6 Bottom panel for Upper Section

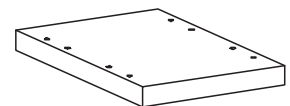

#7 Top panel for Lower Section

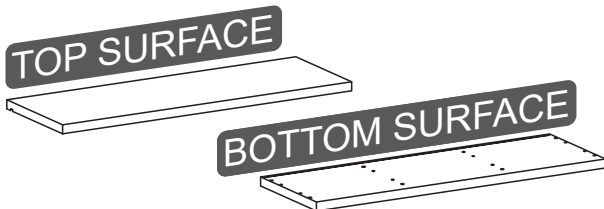

#8 Bottom panel for Lower Section

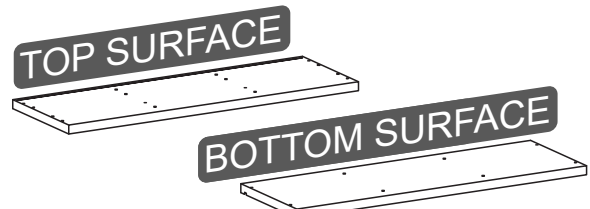

#9 Left panel for Lower Section

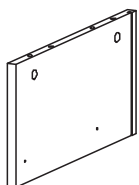

#10 Right panel for Lower Section

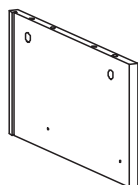

#11 Middle-Left panel for Lower Section

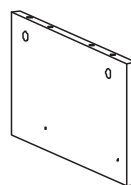

#12 Middle-Right panel for Lower Section

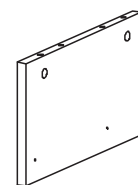

#13 Back board for Lower Section



#14 Drawer front panel

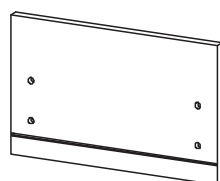

#15 Drawer left panel

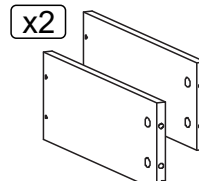

#16 Drawer right panel

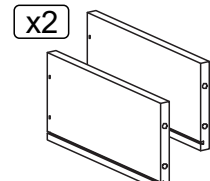

(Continue on Next Page)

MAIN PARTS LIST (Continued)

#17 Drawer back panel

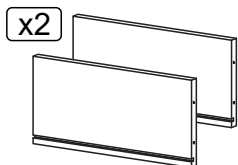

#18 Bottom board for drawers

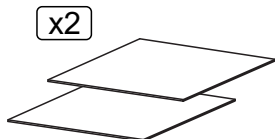

#19-L Sliders, Left Set

1 Left "Flat" piece and
1 Left "L" shape piece per Set.

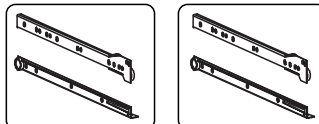

x2 LEFT Sets

#19-R Sliders, Right Set

1 Right "Flat" piece and
1 Right "L" shape piece per Set.

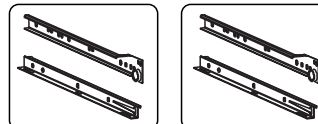



x2 RIGHT Sets

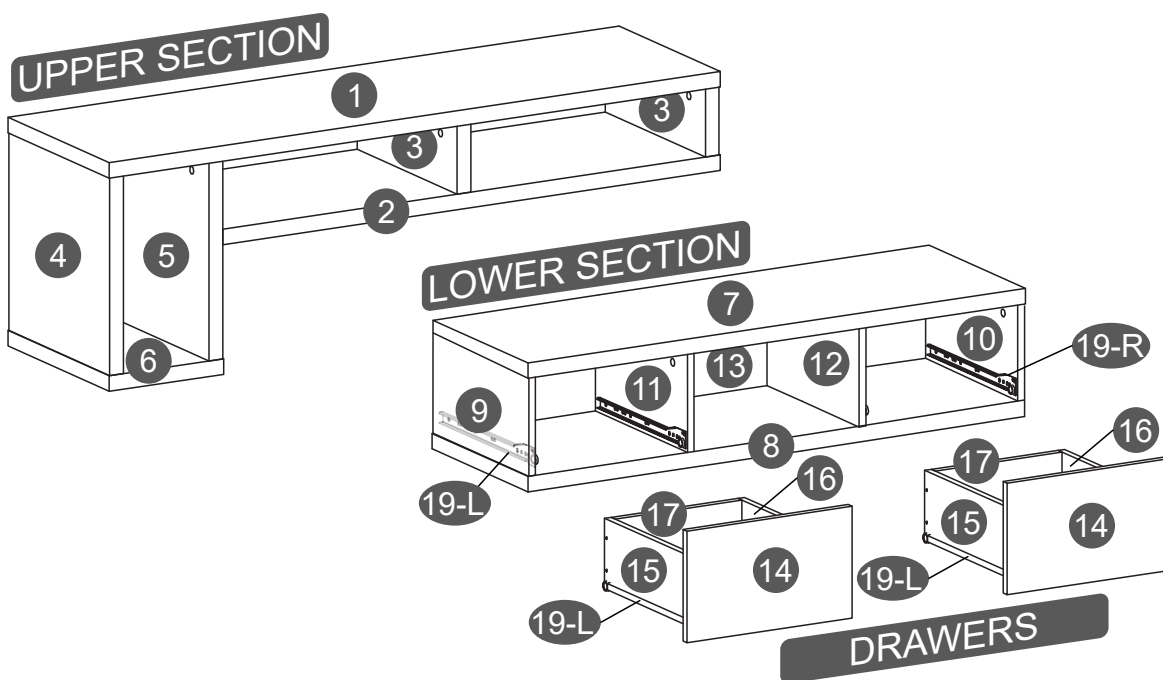

MAIN PARTS LAYOUT (For reference)

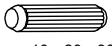
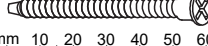
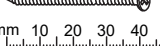

HARDWARE LIST

PART	QTY	SIZE / DESCRIPTION	ITEM
A	26	M6x35 Set of 1 Bolt and 1 Cam Lock	 mm 10 20 30 40 50 60
B	34	Ø8x30mm (Wooden dowel)	 mm 10 20 30 40 50 60
C	16	ST7x58	 mm 10 20 30 40 50 60
D	8	ST3.5x40	 mm 10 20 30 40 50 60
E	16	ST3x14	 mm 10 20 30 40 50 60

HARDWARE LIST

PART	QTY	SIZE / DESCRIPTION	ITEM
F	10	Ø25 (Felt)	 mm 10 20 30 40 50 60
G	8	Ø22 (Laminate)	 mm 10 20 30 40 50 60

TOOLS INCLUDED

Phillips Screwdriver

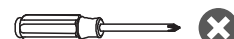

TOOLS REQUIRED BUT NOT INCLUDED

Hammer or Mallet



BEFORE YOU START THE ASSEMBLY, PLEASE READ THE FOLLOWING TIPS AND WARNINGS.

- Do not discard this manual or any of the packaging material until the unit is completely assembled.
- Please read the assembly instructions thoroughly and follow step by step.



- The assembly might require of 2 persons for certain steps. Before you start the installation, make sure there is someone else nearby to help you.



- Make sure you understand which hardware will be used on each step.
- Do not overtighten the screws to avoid stripping, breaking or getting stuck inside the part that is being used.

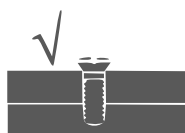
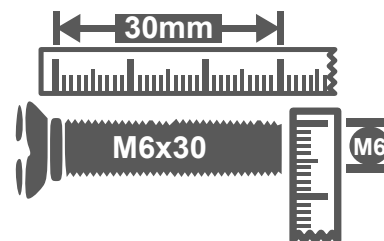

CORRECT SIZE



TOO SHORT!



TOO LONG!



DO NOT OVERTIGHTEN!

- If the hole seems to small for the screw, make sure you are using the correct size of screw and/or that you are installing it in the correct hole.



- Sometimes on the wood panels the laminate or material might be covering the hole partially or entirely, if there is no visible hole or if it looks too small, pass and press the tip of your finger over the area to feel its indentation, and carefully pierce the laminate to uncover the hole underneath.

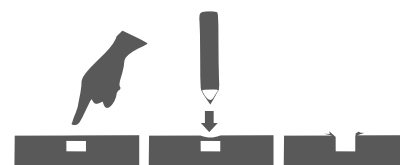

- Please be kind to our planet, when done with the assembly, recycle any of the packaging materials that is accepted by your city or recycling service.



Thank you!



- After the item is assembled, you can use rubbing alcohol to erase or remove the visible part numbers printed or labeled on the pieces.

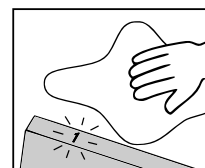

THE ASSEMBLY STEPS START ON NEXT PAGE

CAM BOLT AND CAM LOCK TUTORIAL

THE INSTRUCTIONS BELOW
ARE NOT ACTUAL ASSEMBLY STEPS

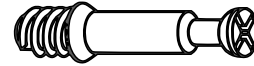

This unit uses cam bolts and locks (also known as mini fixes). If you are not familiar with this kind of hardware, the below is a tutorial that explains how to use them on the steps where they are required.

1. Screw the bolt into the indicated hole on the panel indicated in the assembly step.

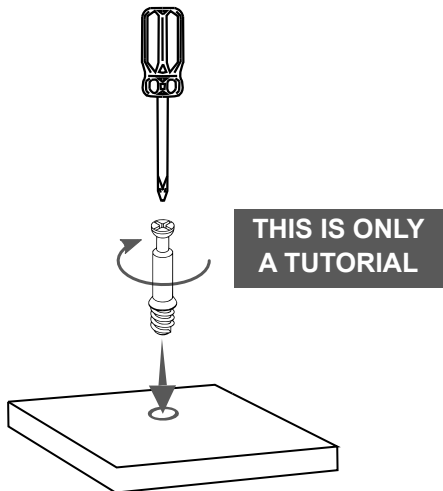

2. Join the other panel (with the big hole) to the panel with the bolt. If it comes with the cam locks already pre-installed, make sure to align them to receive the bolt's head (refer to point 3). There might be a very small gap between the panels which is normal.

If the cam locks come pre-installed, make sure they are aligned (see point 3).

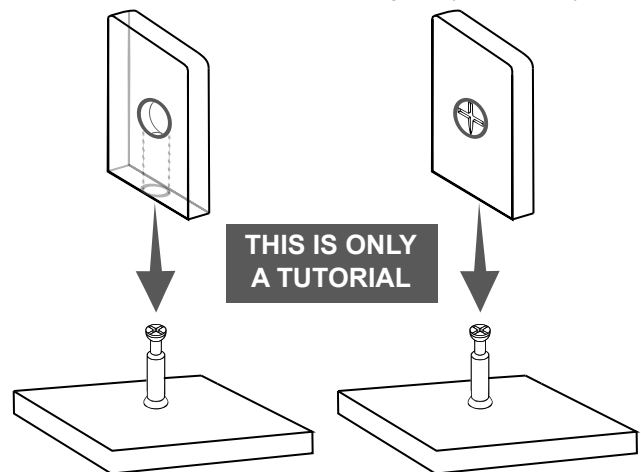

3. Insert the cam lock on the panel with the big hole making sure it goes aligned to receive the bolt's head.

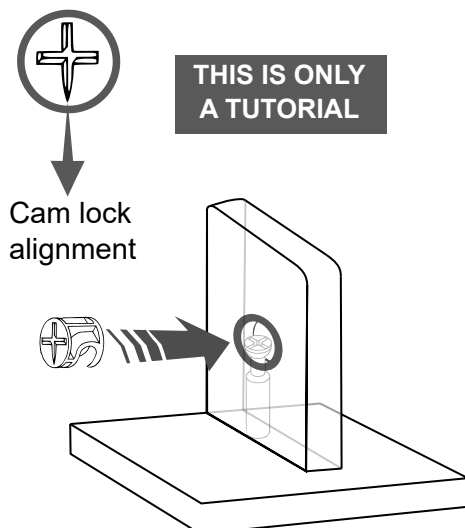

4. Use a Phillips screwdriver to turn the cam lock clockwise. This will lock the panels together and also will close any gaps.

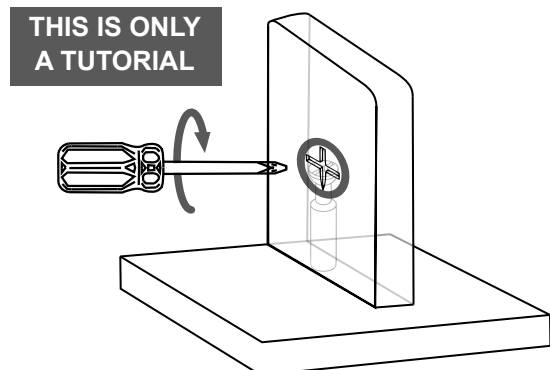

ASSEMBLY STEPS

The assembly is done in 3 stages: First you will assemble the LOWER SECTION, then the DRAWERS and last the UPPER SECTION.

We recommend to place the pieces over blankets or tablecloths to protect their finish during assembly.

STEP 1

Hardware

E  8 Pcs
ST3x14

Tools (included)



FIRST: Grab all the sliders sets 19 and separate them according to their shape:

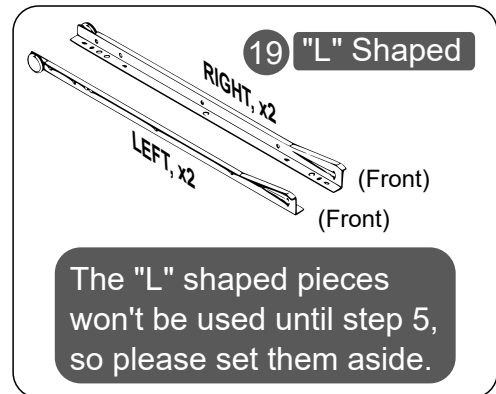
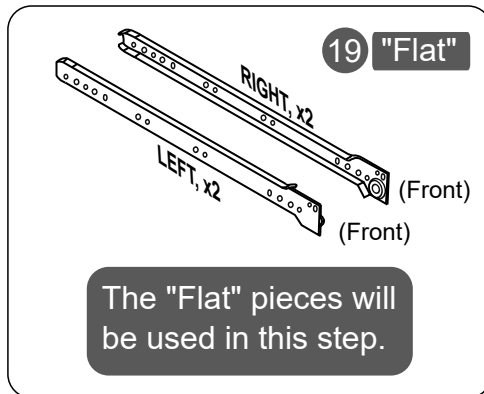

THEN: Identify the FRONT of the sliders and the hole that will be used for the screw.

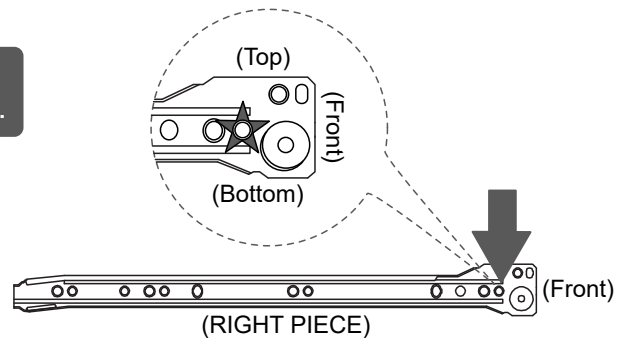
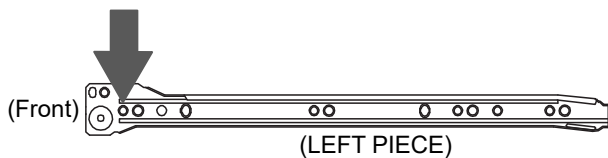

LAST: Attach the sliders #19 to the panels #9, #10, #11 and #12 with screws E **at the front first**, then you can match the back hole.

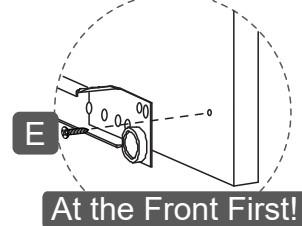
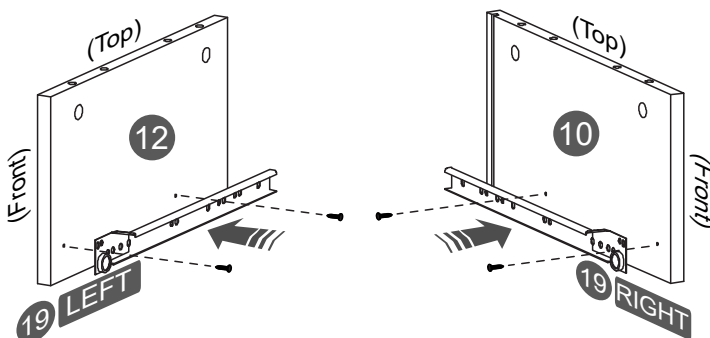
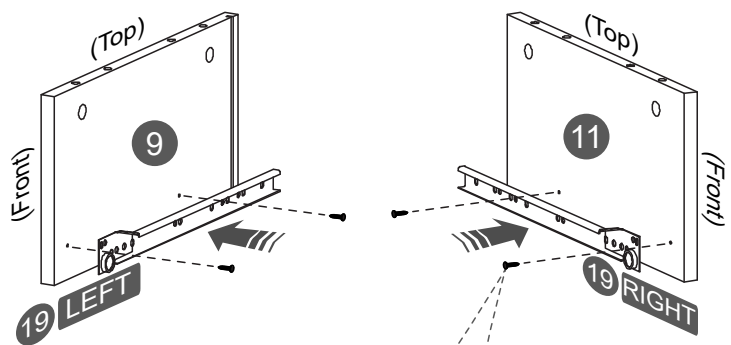

STEP 2

This step
requires of
2 persons



Hardware

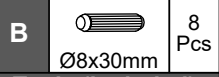

Tools (included)

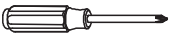

Tools (Not included)

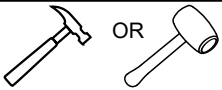

FIRST: Install the bolts A and the dowels B into the indicated holes on panel #7.

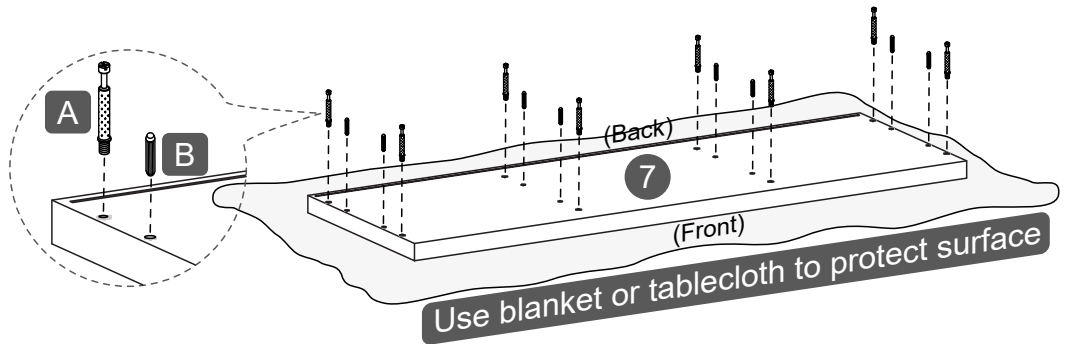

THEN: Install the panels #9, #10, #11 and #12 in the order shown and using cam locks A as explained in the Tutorial page.

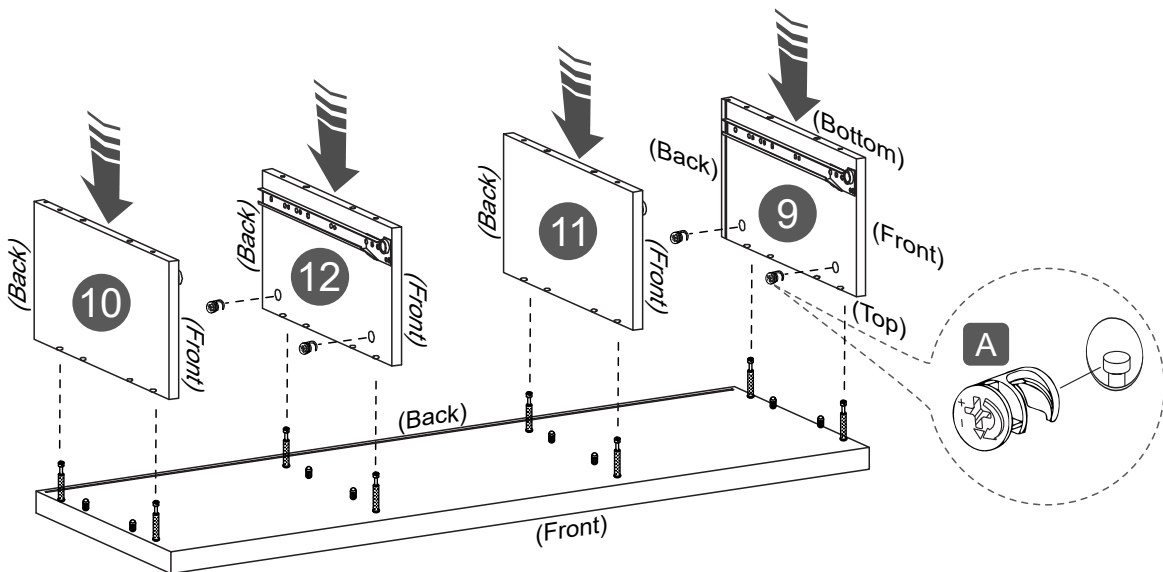

LAST: Slide the back board #13 through the grooves of panels #7, #9 and #10.

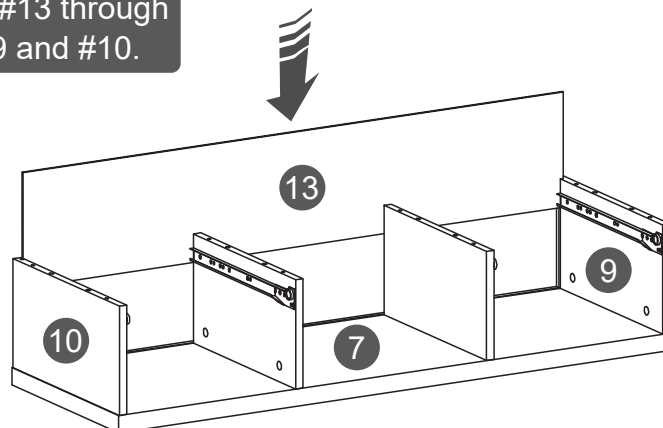

STEP 3

This step requires of 2 persons 

Hardware

B  8 Pcs
Ø8x30mm

C  8 Pcs
ST7x58mm

F  6 Pcs
Ø25 (Felt)

Tools (included)



Tools (Not included)

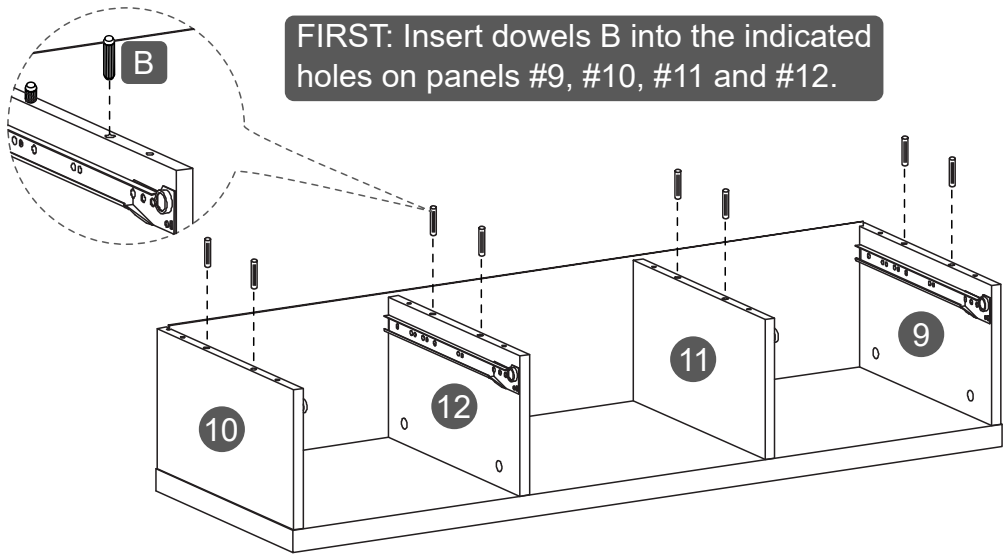

FIRST: Insert dowels B into the indicated holes on panels #9, #10, #11 and #12.

THEN: Assemble the bottom panel #8 to panels #9, #10, #11 and #12 with screws C.

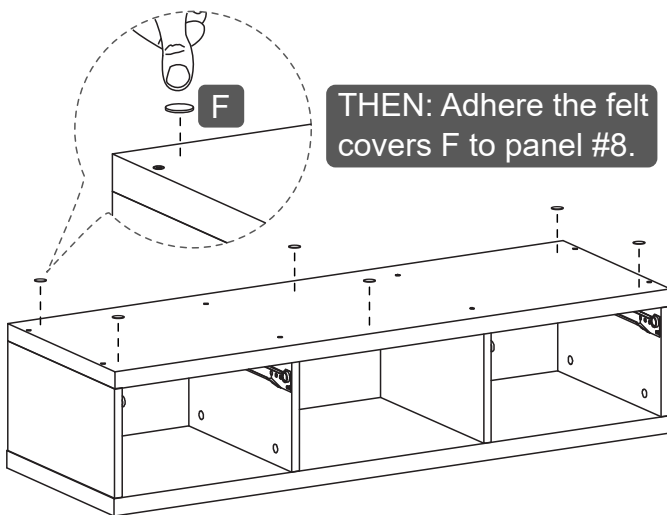
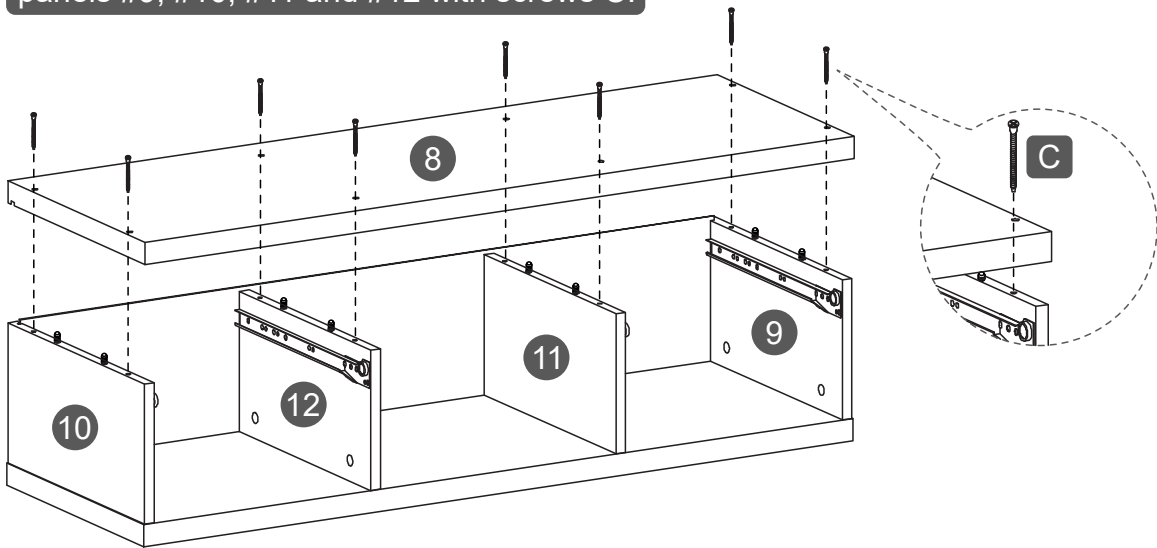

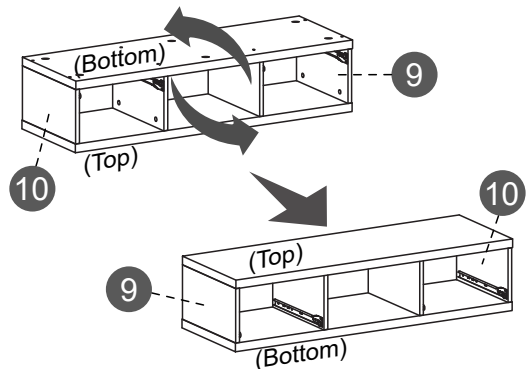

THEN: Adhere the felt covers F to panel #8.

LAST: Flip unit upright.



STEP 4

Hardware

A		8 Sets
D		8 Pcs
Tools (included)		
		

THE HARDWARE IN STEPS 4 AND 5 ARE FOR ASSEMBLING BOTH DRAWERS.

FIRST: Assemble the back panel # 17 to panels #15 and #16 with screws D.

NOTE: All the grooves will align.

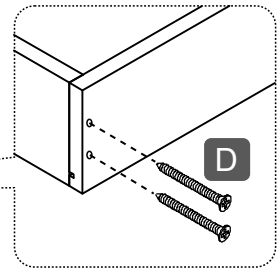
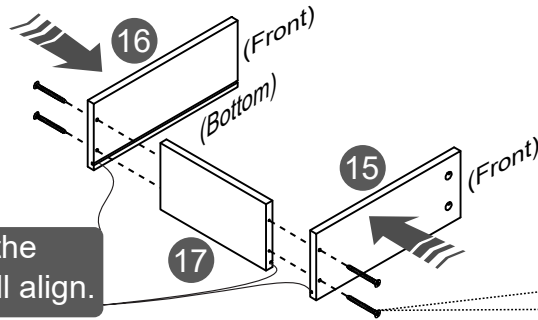

THEN: Slide the bottom board #18 through the grooves of #15, #16 and into #17.

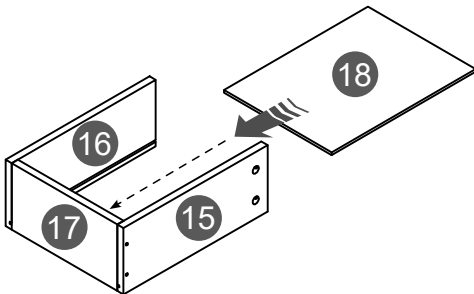

THEN: Install the bolts A into the drawer front panel #14.

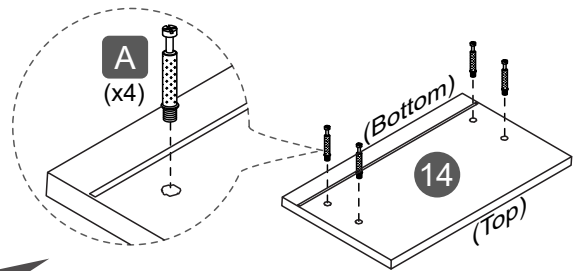

LAST: Assemble the front panel #14 to the side panels #15 and #16 with cam locks A.

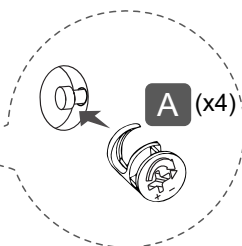
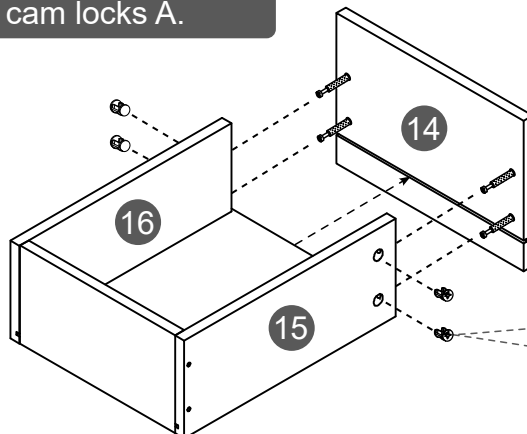

STEP 5

Hardware

E

8
Pcs

Tools (included)

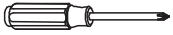

FIRST: Identify on sliders #19 their front and back.

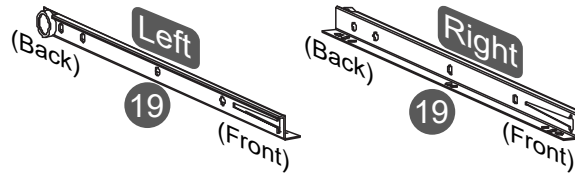

THEN: Put the drawer upside-down and assemble the sliders #19 with screws E.

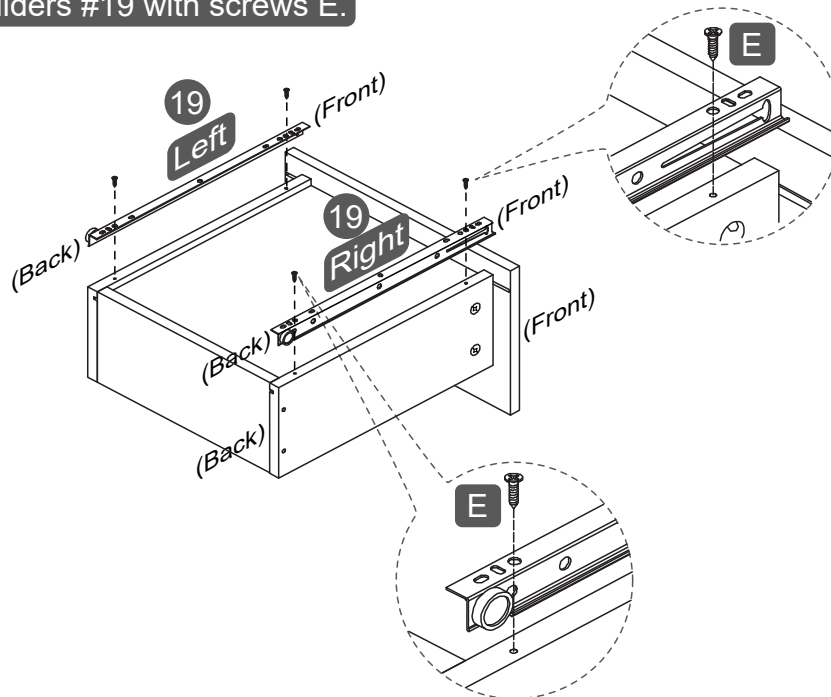

LASTLY, insert the drawers into the bottom section.

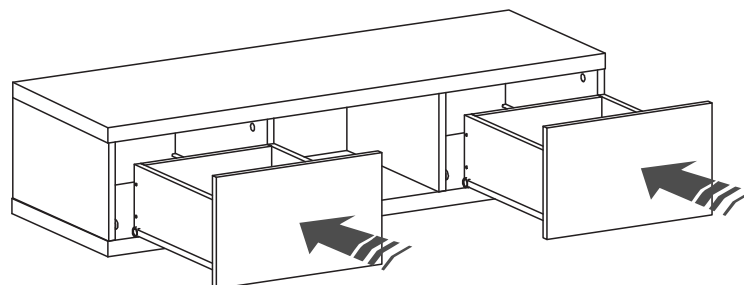



IF THE DRAWERS DON'T SEEM TO FIT:

1. Review and verify that the assembly done in steps 1 and 5 are correct.
2. Make sure the screws in steps 1 and 5 are well tightened and as flushed as possible so their heads are not interfering with the sliders.

STEP 6

Hardware

A		10 Pcs
	Bolt	
A		8 Pcs
	Cam lock	
B		10 Pcs
	Ø8x30mm	

Tools (included)



Tools (Not included)

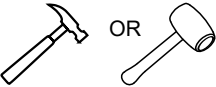

FIRST: Attach the bolts A and the dowels B into the indicated holes on panels #1 and #5.

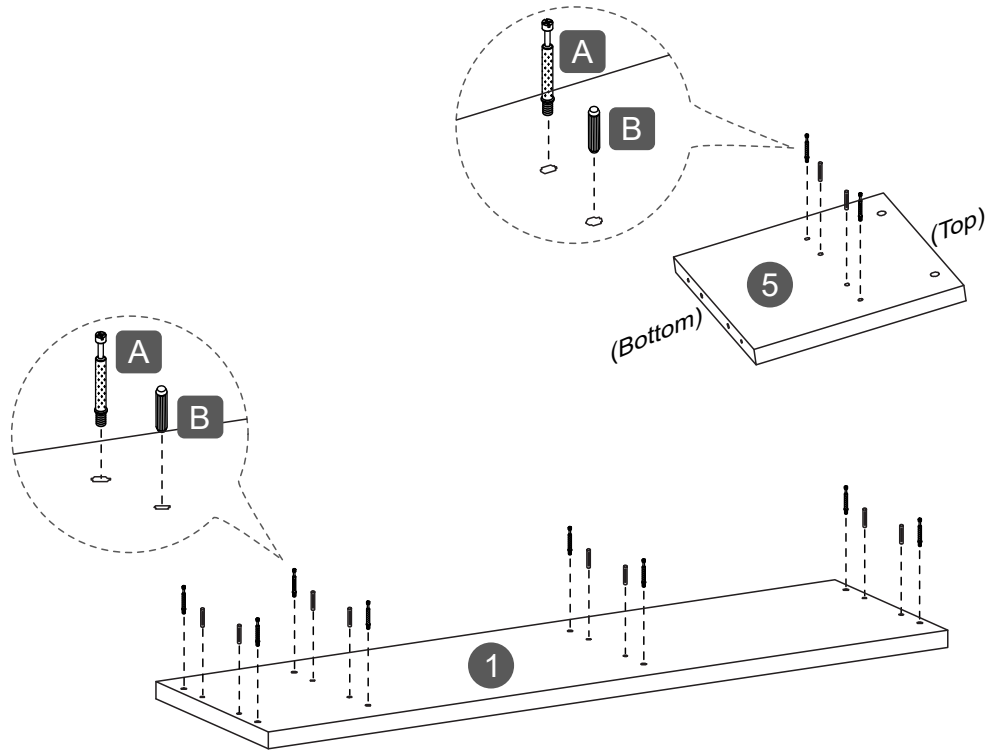

THEN: Assemble the panels #3, #4 and #5 to panel #1 with cam locks A and positioned as indicated.

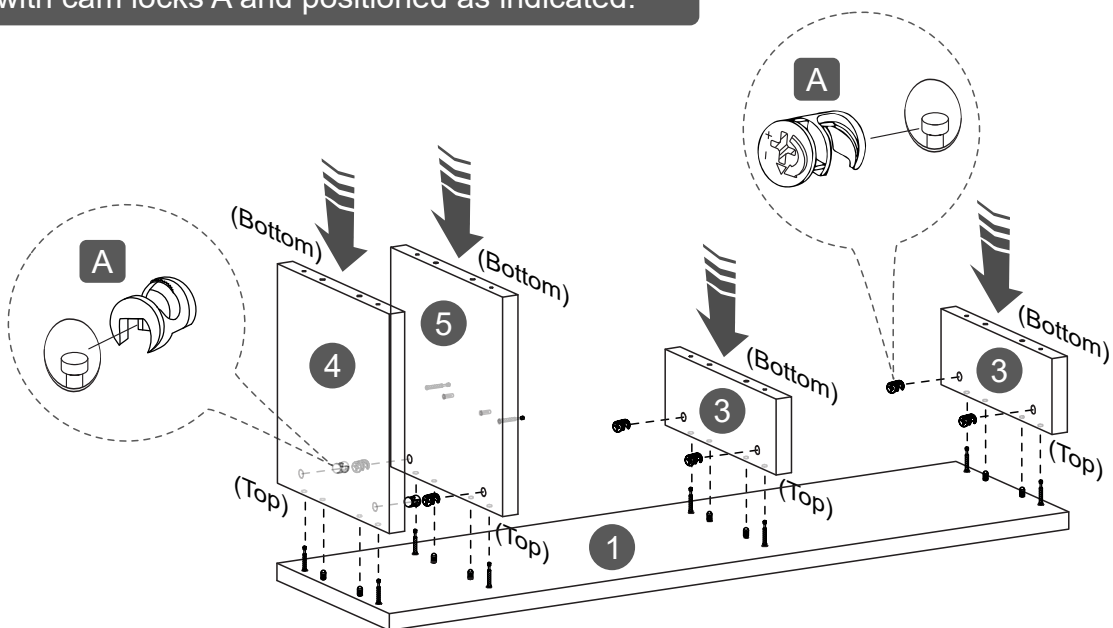



STEP 7

This step
requires of
2 persons



Hardware

A	 Cam Lock	2 Pcs
B	 Ø8x30mm	8 Pcs
C	 ST7x58	4 Pcs

Tools (included)

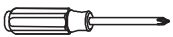

FIRST: Attach the dowels B into the indicated holes on the panels #3, #4 and #5.

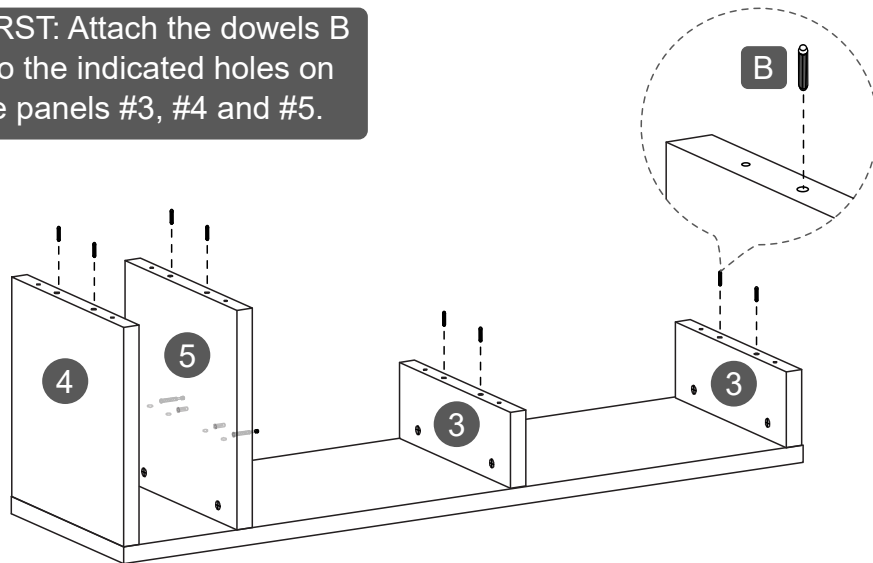

THEN: Assemble the bottom panel #2 to panels #3 and to panel #5 with cam locks A.

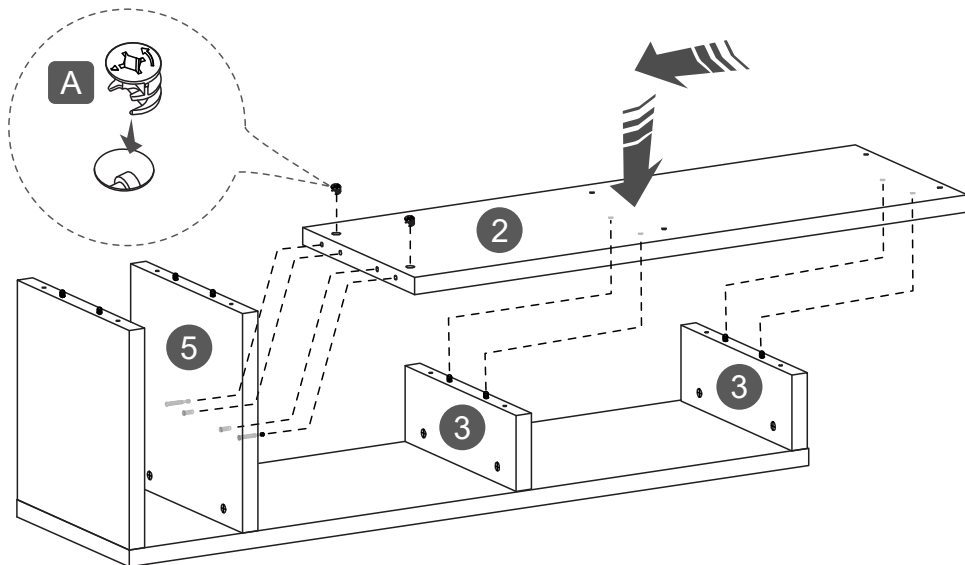

LAST: Secure panel #2 to panels #3 with screws C.

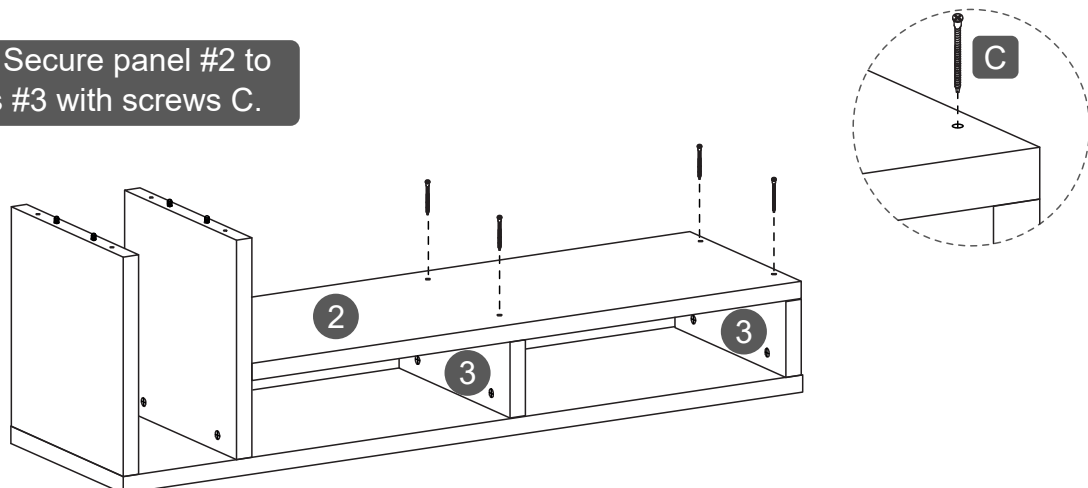

STEP 8

This step requires of  2 persons

Hardware

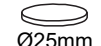
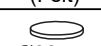
C	 ST7x58	4 Pcs
F	 Ø25mm (Felt)	4 Pcs
G	 Ø22mm (Laminate)	8 Pcs

Tools (included)

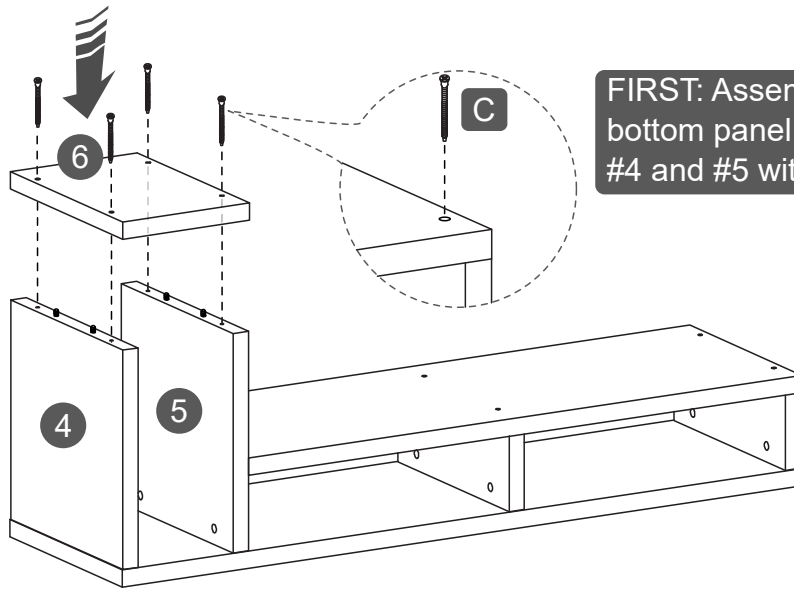

FIRST: Assemble the bottom panel #6 to panels #4 and #5 with screws C.

THEN: Attach the felt stickers F to the corners of panel #6, and use the stickers G to cover the cam locks on panels #3, #4 and #5.

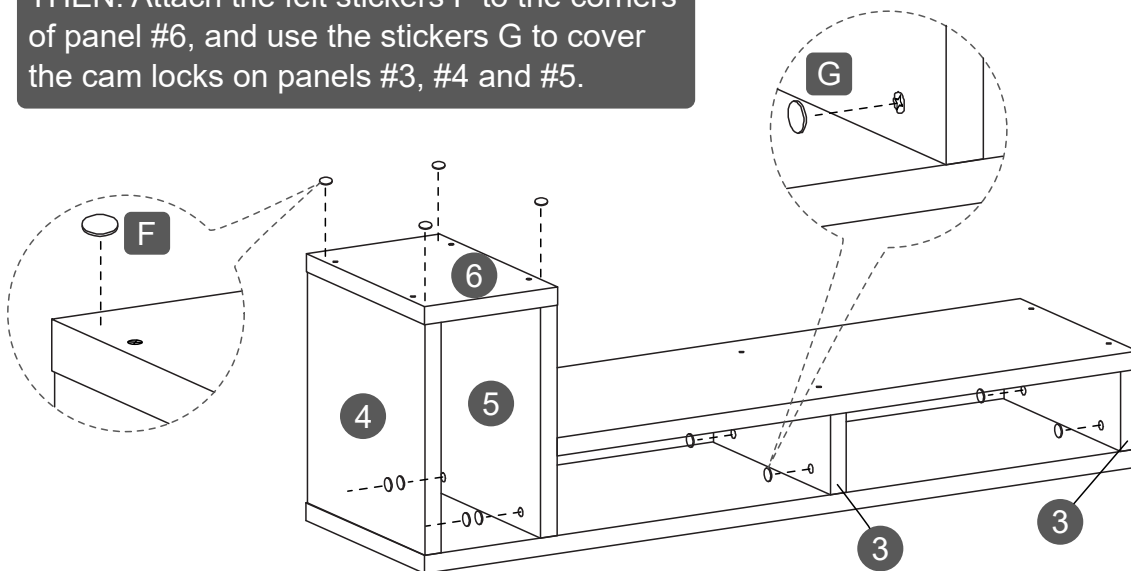

FINALLY: Place the top section over the lower section according to your preference.

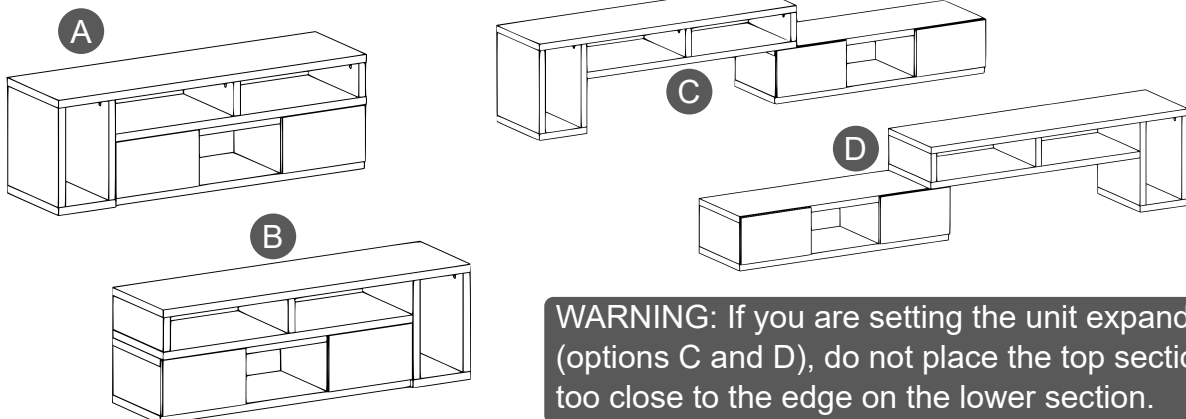

WARNING: If you are setting the unit expanded (options C and D), do not place the top section too close to the edge on the lower section.

TIP-OVER WARNING!

Not paying attention to the following warnings could result in injuries.

Always pay close attention to small children playing near the unit or if they are watching TV very close to it, to prevent tip-over accidents.

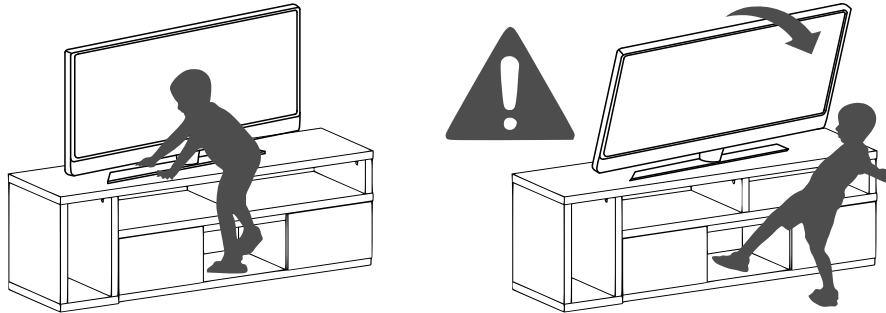

WEIGHT LIMITS - DO NOT EXCEED

88 Lbs (40 Kg) Closed
55 Lbs (25 Kg) Expanded

88 Lbs (40 Kg)

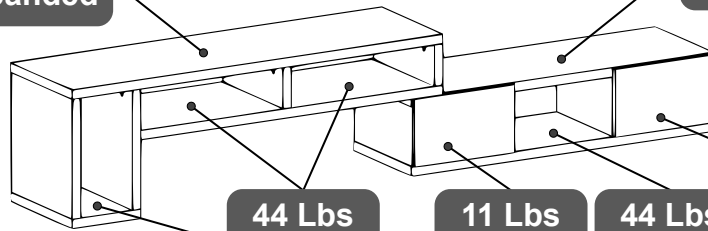

44 Lbs (20 Kg)

11 Lbs (5 Kg)

44 Lbs (20 Kg)

11 Lbs (5 Kg)

DO NOT PLACE THE TOP SECTION TOO CLOSE TO THE EDGE IN THE EXPANDED OPTION.

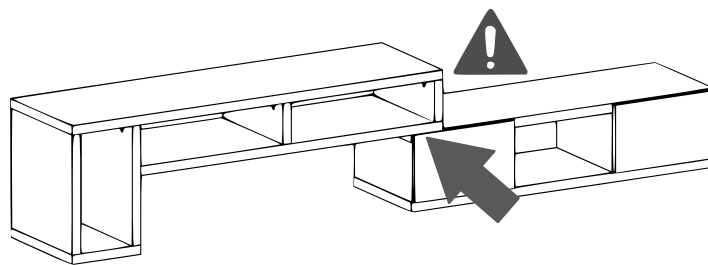

CARE AND MAINTENANCE

Clean with a cloth lightly dampened in a solution of mild soap and water.



Do not use solvents or abrasive materials.



Do not expose to direct sunlight or extreme environmental conditions.

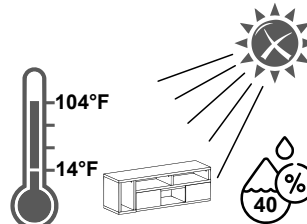

Inspect and re-tighten loose screws on the table every 4 months.

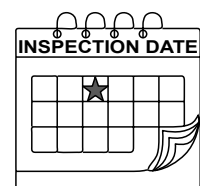

TECHNI MOBILI WARRANTY



RTA Products, LLC warrants to the Original Purchaser who acquired a new product from RTA Products or its authorized resellers that this product will be free from defects in its workmanship and materials, under normal use and service conditions, as described herein. "Defects" as used in this warranty, is defined as any imperfections that impair the use of the furniture or product. RTA products will repair or replace, at its option, without charge to the original purchaser 'other than freight from purchaser to RTA Products, only the defective products or parts for a period of TWO (2) Years.

Replacement parts can only be supplied if parts are available. Items out of production may be unavailable. This warranty will be effective for the applicable time period beginning the date of purchase on your original sales receipt. RTA product's obligation under this warranty is limited to repairing or replacing products or parts as provided herein. This product has been designed for and is intended for office and home-office use only. This warranty is Original Purchaser's sole remedy for product defects, and this warranty does not extend to any product, or damage to any product, caused by or attributed to abuse or misuse, products used for commercial or rental purposes, use modifications of, or attachments to the product, and products or parts not used, maintained, or extended hereunder is in lieu of any and all other warranties, express or implied, including without limitations any implied warranty or merchantability or of fitness for a particular purpose. Please note, all desks made with PVC Laminate surface should not be exposed to direct sunlight, as it may damage the material. Damage of this nature is not covered under this warranty.

RTA Products will not be responsible for indirect, special, incidental or consequential damages. This warranty is limited to merchandise purchased in the Continental United States, excludes AK, HI and PR. Some States do not allow the exclusion or limitation of incidental or consequential damages, so the above limitations or exclusions may not apply to you. This warranty gives you specific legal rights. You may also have other rights that may vary from state to state.

To file a Claim within the 48 contiguous United States: Email us to warranty@rtaproducts.com to explain the defect and provide your name, address, phone number, model number of our product, date and place, and proof of purchase. Please provide pictures of the damage or defect.

If we determine that a replacement will remedy the situation, and in order to determine the extent or the cause of the defect, purchaser may be requested to send the part in question at purchaser's expense. Once we receive the part, we will examine it and determine whether the claim is valid (or not), and then proceed to send the replacement. We will ship the replacement at our expense.

Replacement Parts for International Customers & AK-HI-PR orders:

RTA Products will replace the part free of charge, while the customer is responsible for shipping costs plus any International local taxes or duties.