

ASSEMBLY INSTRUCTIONS

5PC ADLER DINING SET

ASSEMBLY REQUIREMENTS

2-Person
AssemblyAssembly Time
(Approximate)

30 MINUTES

Thank you for purchasing our product!

Please refer and use this assembly instruction to assemble the product.
Contact our customer service department in case there are any missing or damage parts or hardware. Replacement parts are normally shipped within 2 or 3 days.

Email: replacementparts@buylateral.com
Within 30 days from delivery date

**PRODUCTS PURCHASED THROUGH OUR
AUTHORIZED VENDORS ONLY ARE
ELIGIBLE FOR REPLACEMENT PARTS**

We appreciate your business!

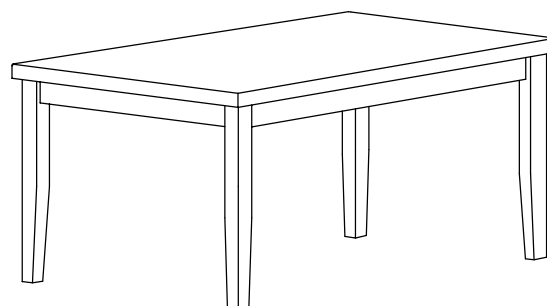

**THIS PRODUCT IS FOR INDOOR AND HOUSEHOLD USE ONLY
- NOT FOR COMMERCIAL USE.**

ASSEMBLY PREPARATION

1. Remove all packaging materials, staples and packing straps from the carton.
2. Refer to Part List and Hardware List and ensure they are complete before you start assembling.
3. Place all wooden parts on a clean, flat and soft surface (e.g. carpet or rug) to prevent parts from getting scratched.

SAFETY PRECAUTION

1. KEEP ALL HARDWARE PARTS OUT OF REACH OF CHILDREN.
2. DISPOSE PLASTIC PACKAGING MATERIAL IMMEDIATELY TO AVOID ANY RISK OF SUFFOCATION TO CHILDREN AND ANIMALS.

TIPS FOR ASSEMBLY

1. Allow ample room for assembly and in close proximity to where product will be placed.
2. Assemble the product on a surface that does not scratch or damage the exterior gloss and finish of the furniture.
3. Please check all of the parts and quantities are included before assembly. Contact customer service for missing parts.
4. Identify all of the parts, hardware and quantities required for each step.
5. During assembly, do not over-tighten any fittings as this may cause damage.
6. DO NOT USE POWER TOOLS TO ASSEMBLE THIS PRODUCT.
7. Always place the product on a flat surface.
8. Do not sit or stand on the partially assembled product; only use the product for which it is intended.

CARE AND MAINTENANCE

- Wipe clean with a soft, dry cloth; avoid the use of harsh chemicals or household cleaners as they may damage the exterior finish of the furniture.
- Hardware may loosen over time. Periodically, check that all connections are tight; re-tighten as necessary.
- Solid wood is impacted by heat and humidity fluctuations which may cause small joint separations or hairline cracks; place the furniture away from direct sunlight and air conditioning vents, heating vents or units to protect the furniture.





ASSEMBLY INSTRUCTIONS

5PC ADLER DINING SET

PARTS LIST

NO.	COMPONENT	QTY.
P1	TABLE TOP WITH APRON	1 PC.
P2	TABLE LEG	4 PCS.

HARDWARE LIST

NO.	DESCRIPTION	QTY.	EXTRA
H1	HEX BOLT 5 / 16" x 2-1/2" 	8 PCS.	1 PC.
H2	SPRING WASHER 5/16" 	8 PCS.	1 PC.
H3	FLAT WASHER 5/16" 	8 PCS.	1 PC.
H4	WRENCH 	1 PC.	-

*EXTRA HARDWARE FOR SPARE USE

STEP 1

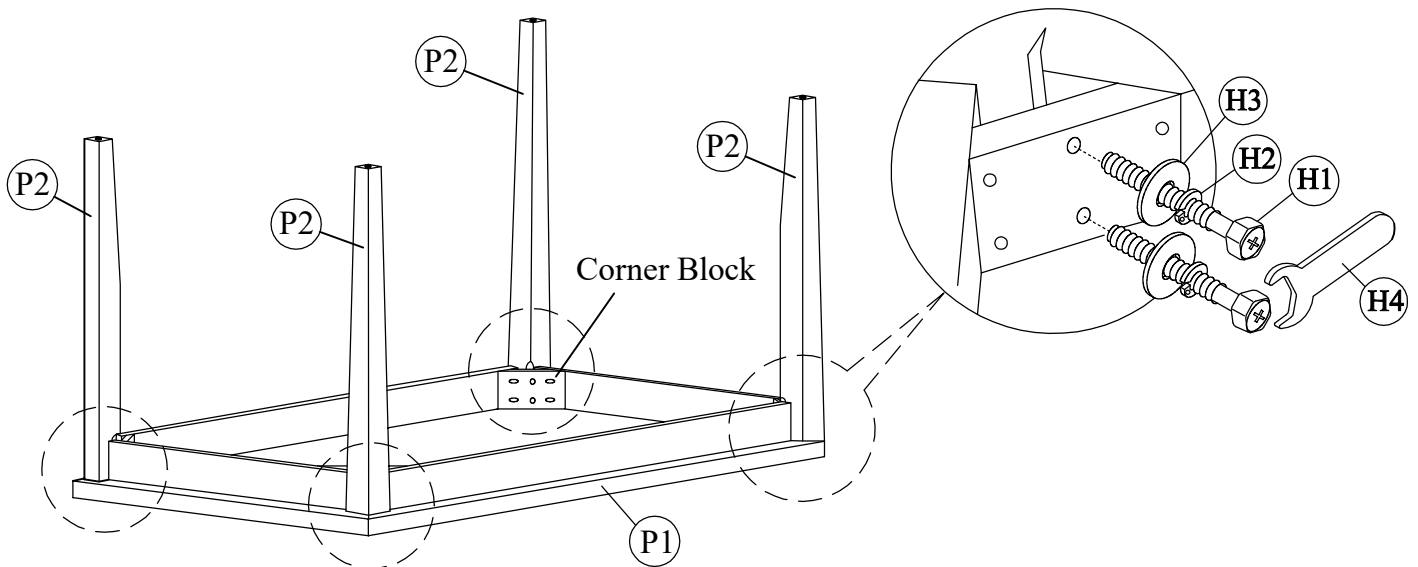

- a) With the assistance of another person, place Table Top (P1) bottom-side up on a flat, level surface and material that does not scratch or damage the part.
- b) Position a Table Leg (P2) against a corner of the table aprons and align the screw holes on (P2) to the screw holes on the corner block.
- c) Insert Hex Bolt (H1) fitted with Spring Washer (H2) and Flat Washer (H3) into each hole. Use Wrench (H4) to drive (H1) to fasten Table Leg (P2) to corner block. Do not tighten (H1) completely until both bolts are in place - **do not over-tighten**.
- d) Repeat the above assembly procedure for the other three table legs .

With the assistance of another person , set the table right-side up. The assemble of the table is complete.

ASSEMBLY INSTRUCTIONS

5PC ADLER DINING SET

**ASSEMBLY
REQUIREMENTS**

1-Person
Assembly

30 Minutes
Assembly Time Per Chair
(Approximate)

Tool Required
(Not Provided)

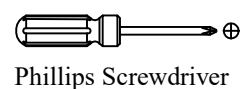
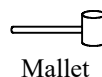

Thank you for purchasing our product!

Please refer and use this assembly instruction to assemble the product.
Contact our customer service department in case there are any missing or damage parts or hardware. Replacement parts are normally shipped within 2 or 3 days.

Within 30 days from delivery date

**PRODUCTS PURCHASED THROUGH OUR
AUTHORIZED VENDORS ONLY ARE
ELIGIBLE FOR REPLACEMENT PARTS**

We appreciate your business!

**THIS PRODUCT IS FOR INDOOR AND HOUSEHOLD USE ONLY
- NOT FOR COMMERCIAL USE.**

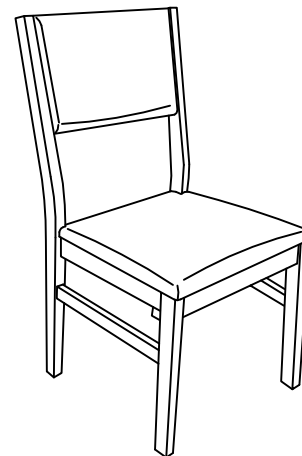

ASSEMBLY PREPARATION

1. Remove all packaging materials, staples and packing straps from the carton.
2. Refer to Part List and Hardware List, and ensure parts and hardware are complete before you start assembling. Contact customer service for missing parts.
3. Place all wooden parts on a clean, flat and soft surface (e.g. carpet or rug) to prevent parts from getting scratched.

SAFETY PRECAUTION

1. KEEP ALL HARDWARE PARTS OUT OF REACH OF CHILDREN.
2. DISPOSE PLASTIC PACKAGING MATERIAL IMMEDIATELY TO AVOID ANY RISK OF SUFFOCATION TO CHILDREN AND ANIMALS.

TIPS FOR ASSEMBLY

1. Allow ample room for assembly and in close proximity to where product will be placed.
2. Assemble the product on a surface that does not scratch or damage the exterior gloss and finish of the furniture.
3. Check all of the parts and quantities are included before assembly.
4. Identify all of the parts, hardware and quantities required for each step.
5. During assembly, do not over-tighten any fittings as this may cause damage.
6. DO NOT USE POWER TOOLS TO ASSEMBLE THIS PRODUCT.
7. Always place the product on a flat, level surface.
8. Do not sit or stand on the partially assembled product; only use the product for which it is intended.

CARE AND MAINTENANCE

- Wipe clean with a soft, dry cloth; avoid the use of harsh chemicals or household cleaners as they may damage the exterior finish of the furniture.
- Hardware may loosen over time. Periodically, check that all connections are tight; re-tighten as necessary.
- Solid wood is impacted by heat and humidity fluctuations which may cause small joint separations or hairline cracks; place the furniture away from direct sunlight and air conditioning vents, heating vents or units to protect the furniture.

ASSEMBLY INSTRUCTIONS

5PC ADLER DINING SET

PARTS LIST (FOR 4 CHAIRS)

NO.	COMPONENT	QTY.
P1	BACK CUSHION	4 PCS.
P2	LEG FRAME (LEFT & RIGHT)	8 PCS.
P3	FRONT RAIL	4 PCS.
P4	BACK RAIL	4 PCS.
P5	CUSHION SEAT	4 PCS.

HARDWARE LIST (FOR 4 CHAIRS)

NO.	DESCRIPTION	QTY.	EXTRA
H1	JCBC BOLT M6 x 60 MM	32 PCS.	1 PC.
H2	BARREL NUT	16 PCS.	1 PC.
H3	WOOD DOWEL M8 x 30MM	32 PCS.	1 PC.
H4	CB SCREW M4 x 32MM	20 PCS.	1 PC.
H5	ALLEN KEY	1 PC.	-

*EXTRA HARDWARE FOR SPARE USE

Instructions to install Barrel Nut

STEP 1

Insert Barrel Nut with the perpendicular hole facing and in-line with the drill hole that the bolt is to be inserted.

STEP 2

Use a Flat-head Screwdriver to hold Barrel Nut in position before inserting bolt to thread into the Barrel Nut.

STEP 1

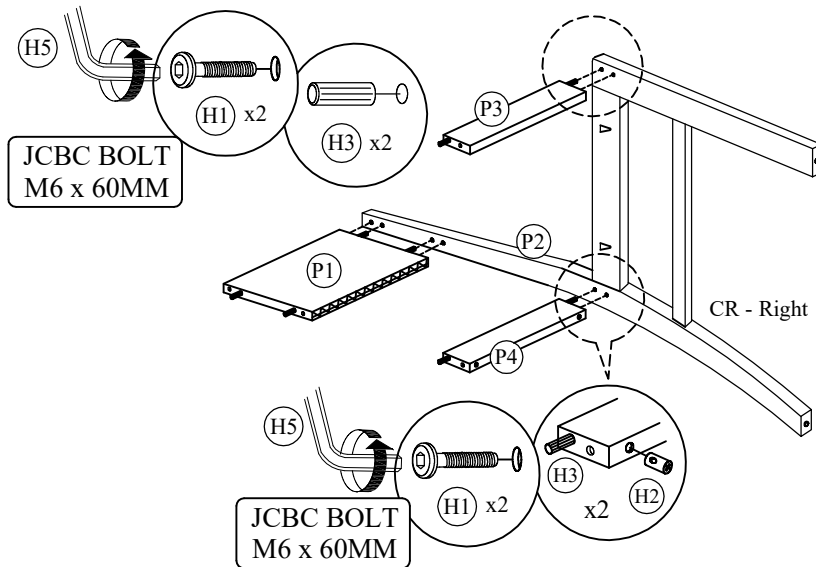

- Position Right Leg Frame (P2) Back Cushion (P1), Front Rail (P3) and Back Rail (P4) as shown on a material that does not scratch or damage the parts.
- Insert Wood Dowel (H3) into designated holes on (P1), (P3) and (P4) as indicated. Use a mallet to lightly tap in Wood Dowel if necessary.
- Fasten (P1) to (P2) with JCBC Bolt (H1). Use Allen Key (H5) to drive and tighten (H1). Do not over-tighten
- Insert Barrel Nut (H2) into Front Rail (P3) and Back Rail (P4) as shown. Ensure hole of Barrel Nut is aligned to the drill-hole. Refer to Instruction to install Barrel Nut.
- Fasten Front Rail (P3) and Back Rail (P4) to (P2) with JCBC Bolt (H1). Use Allen Key (H5) to tighten (H1). Do not over-tighten

ASSEMBLY INSTRUCTIONS

5PC ADLER DINING SET

STEP 2

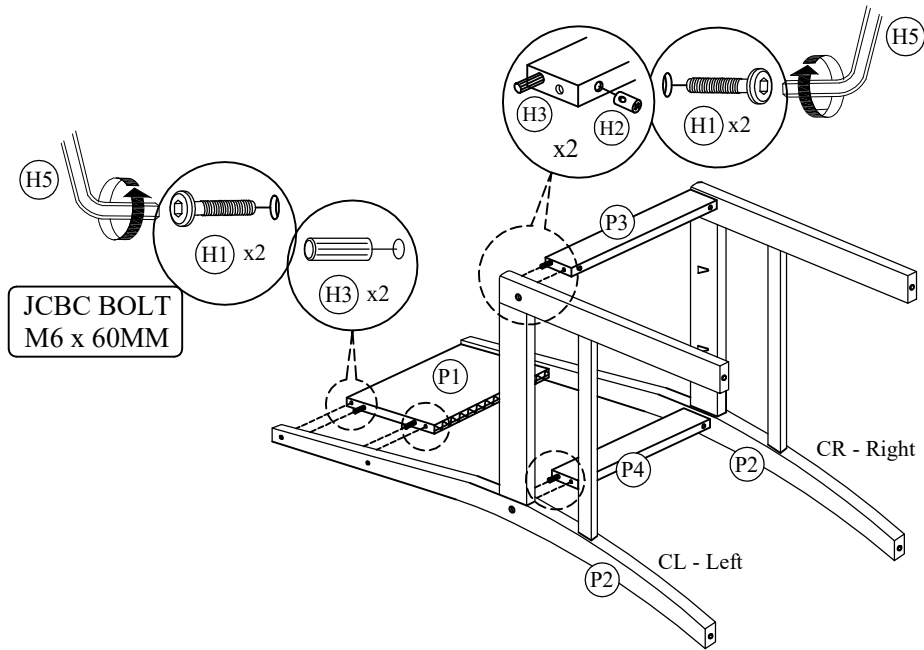

- a) Attach Left Leg Frame (P2) to Back Cushion (P1) , Front Rail (P3) and Back Rail (P4) as shown.
- b) Fasten Left Leg Frame (P2) to (P1) with JCBC Bolt (H1). Use Allen Key (H5) to drive and tighten (H1). Do not over-tighten
- c) Insert Barrel Nut (H2) into Front Rail (P3) and Back Rail (P4) as shown. Ensure hole of Barrel Nut is aligned to the drill-hole.
- d) Fasten Left Leg Frame (P2) to Front Rail (P3) and Back Rail (P4) with JCBC Bolt (H1). Use Allen Key (H5) to tighten (H1). Do not over-tighten

STEP 3

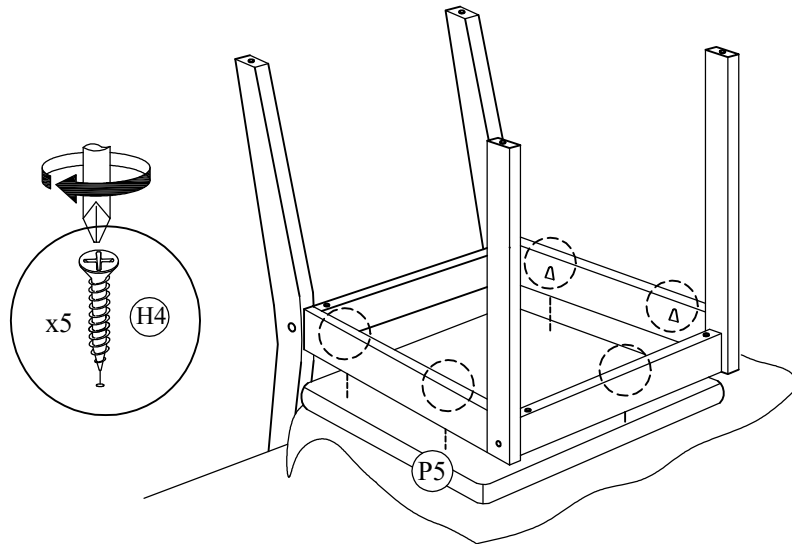

- a) Place Cushion Seat (P5) bottom-side up on an elevated surface (e.g. table top).
- b) Position the chair frame assembly from STEP 2 with the legs facing up as shown and center seat frame to Cushion Seat (P5) with rear of the Cushion Seat against the chair back.
- c) Use Screw (H4) to fasten (P5) to the front and side apron of the seat frame. Use a Phillips screwdriver to drive the screws. Do not tighten the screws completely until all the screws are in place.

Set the chair right-side up. The assembly of the chair is complete.