

Installation & Assembly

Storage Shed

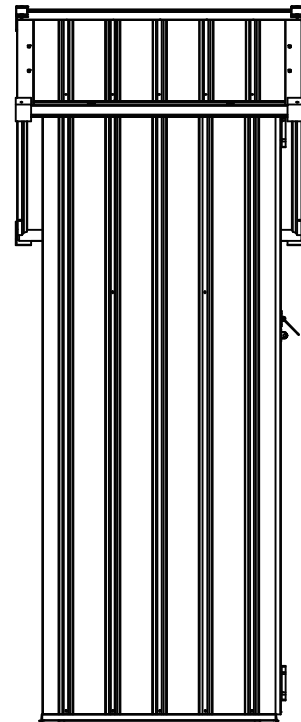

Customer Service:

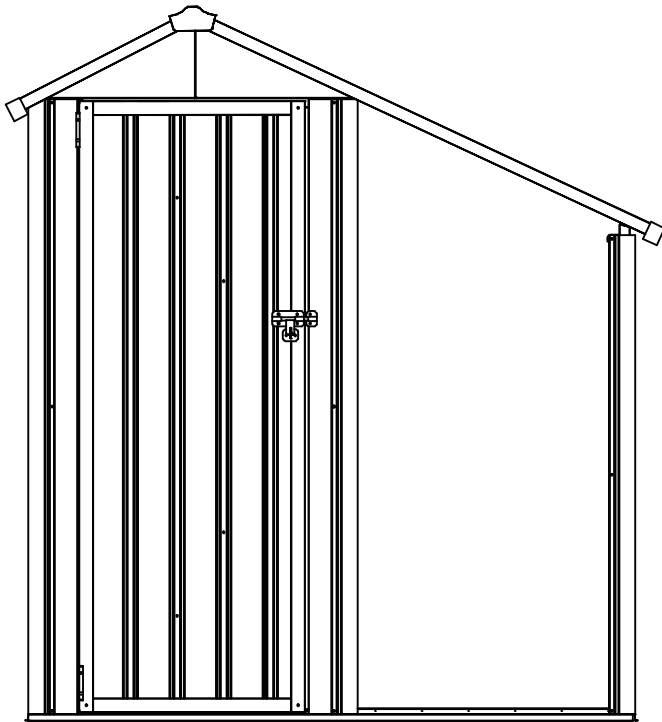

If you have any problem, please contact us through the online platform.

Shed Size

Shed Overall Size:L59.84*W25.98*HS3.78

All parts are packed in two boxes, please note that refer to the parts list to check if all parts are received.

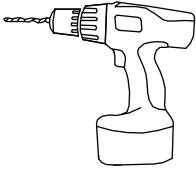
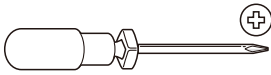
Please prepare below tools before installation. (Not Included)

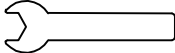
 Electric Screwdriver	 + Manual Screwdriver	 Ladder
Package included Tools	 Gloves x 1Pair	 Spanner x 1

ATTENTION

Care **MUST** be taken when handing various pieces of your building since many contain sharp edges.

Do NOT attempt to assemble your building before double checking that you have all parts indicated in the parts lists. Any building left partially assembled may be seriously damaged by even light winds.

Do NOT attempt to assemble your building on a windy day, the large panels can catch the wind like a “sail”, making construction difficult and unsafe. **Watch the weather closely.** Keep children and pets away from the worksite during construction and until the building is completely assembled. This will help avoid distractions and any accidents which may occur. Never concentrate your weight on the roof of the building.

Before assembling any parts, your base should be constructed and an anchoring system should be ready to use. Your building must be anchored to prevent wind damage.

ASSEMBLY

The best location is a level area with good drainage.

Allow enough space outside the building to be able to access the roof with a ladder.

USE TEAMWORK: Two or more people are required to assemble your building.

CARE & MAINTENANCE

Do NOT use power washing to clean your shed.

Combustibles and corrosives must be stored in air tight containers designed for chemical and/or combustible storage.

Rust Protection Precautions

Avoid nicking or scraping the coating surface, inside and out.

PLEASE KEEP THIS INSTRUCTION FOR FUTURE REFERENCE.

Part List

PART	NO.	QTY.
	T12	1
	T22	2
	K26-0	1
	K26-1	2
	K26-2	2
	K26-3	3
	K26-4	2
	K26-5L	2
	K26-5R	2
	K26-6	2
	K26-9A	2
	K26-9B	2
	K23-12	2
	K26-10	1
	K23-10	2
	K26-12	2
	C23-8	6
	C23-9	6
	K26ULA	1
	K26URA	1
	K26DLA	1
	K23DRA	1
	DDB	2
	K23DX1	2
	GE	2
	C15	8
	DCS	1

PART	NO.	QTY.
	K23W3-C	2
	K23W3	3
	K23W3-B	2
	K26W3-CL	1
	K26W3-CR	1
	K26W3-C	2
	K26W3	1
	K23W3-X	1
	K23W3-HX	1
	K26-7L	1
	K26-7M	1
	K26-7R	1
	K26-8L	1
	K26-8M	1
	K26-8R	1
	K26-11	4
	GC	4
	T-F	4
	F1	192
	F2	44
	F4	4
	V2	36
	C2	4
	C2-2	2
	DJ	2
	M4	1
	ST	2

NOTE: This is **not the beginning** of the installation steps; it is merely to indicate where each component will be installed.

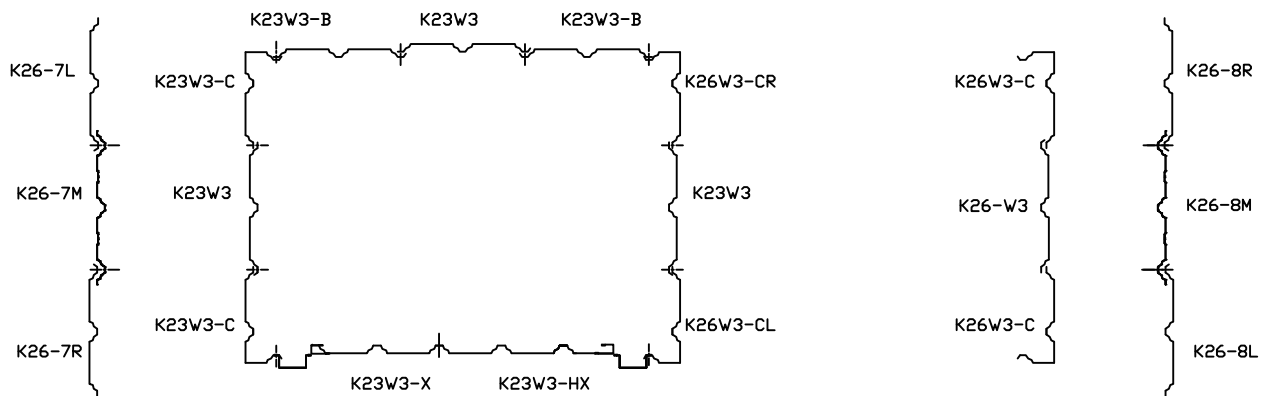

Part List

NOTE: This is **not the beginning** of the installation steps; it is merely to indicate where each component will be installed.

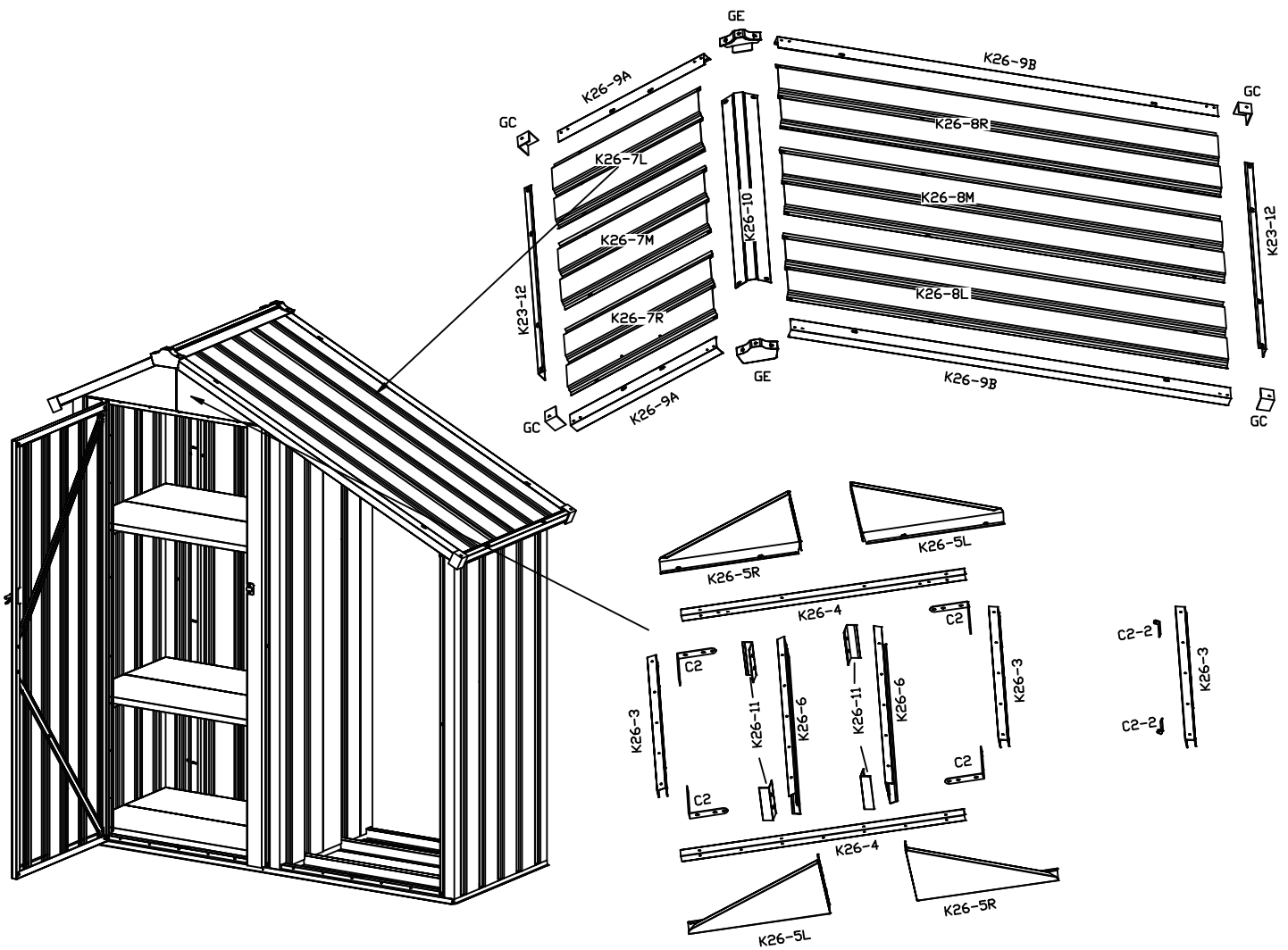



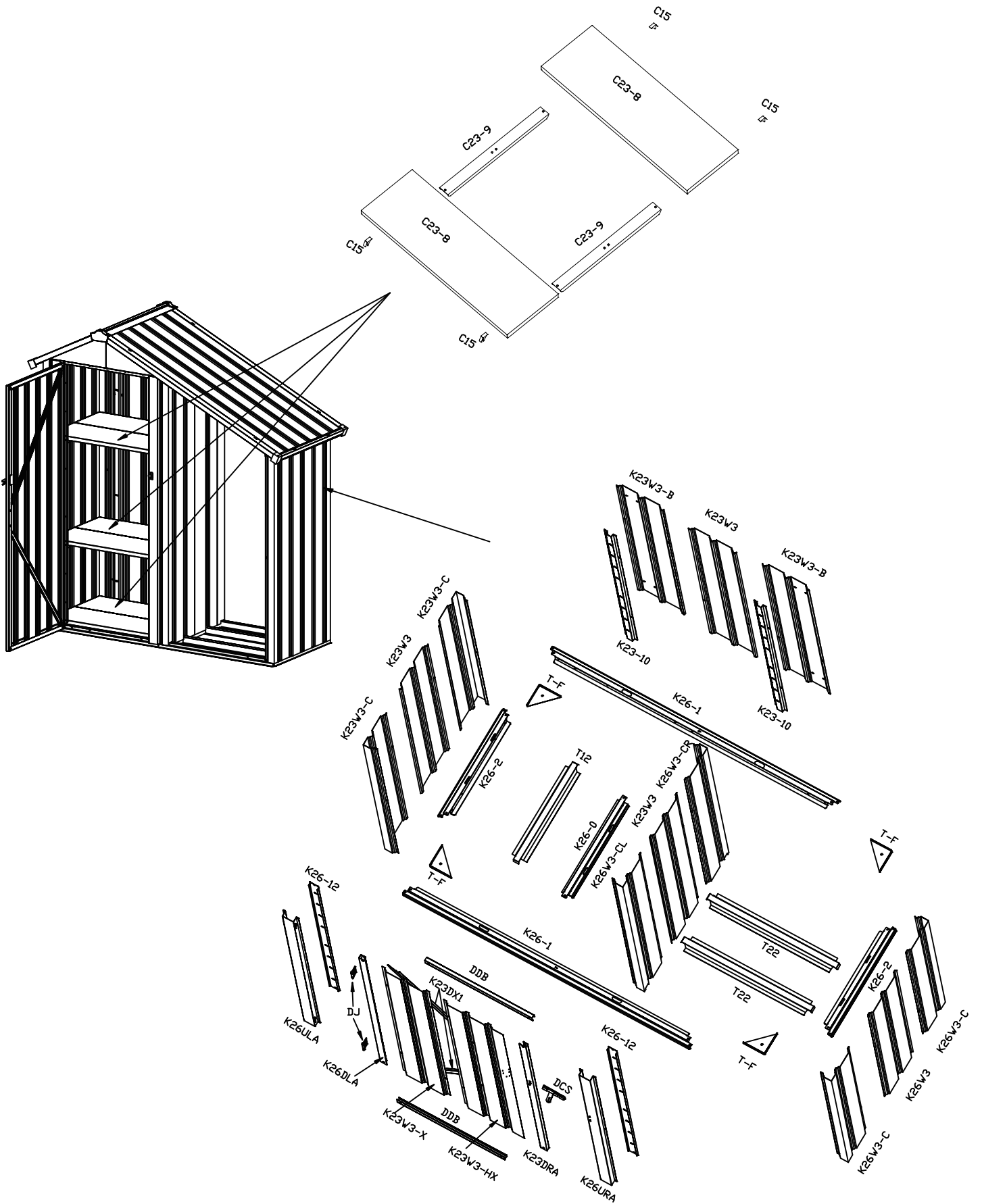

Part List



Side Panel Assemble



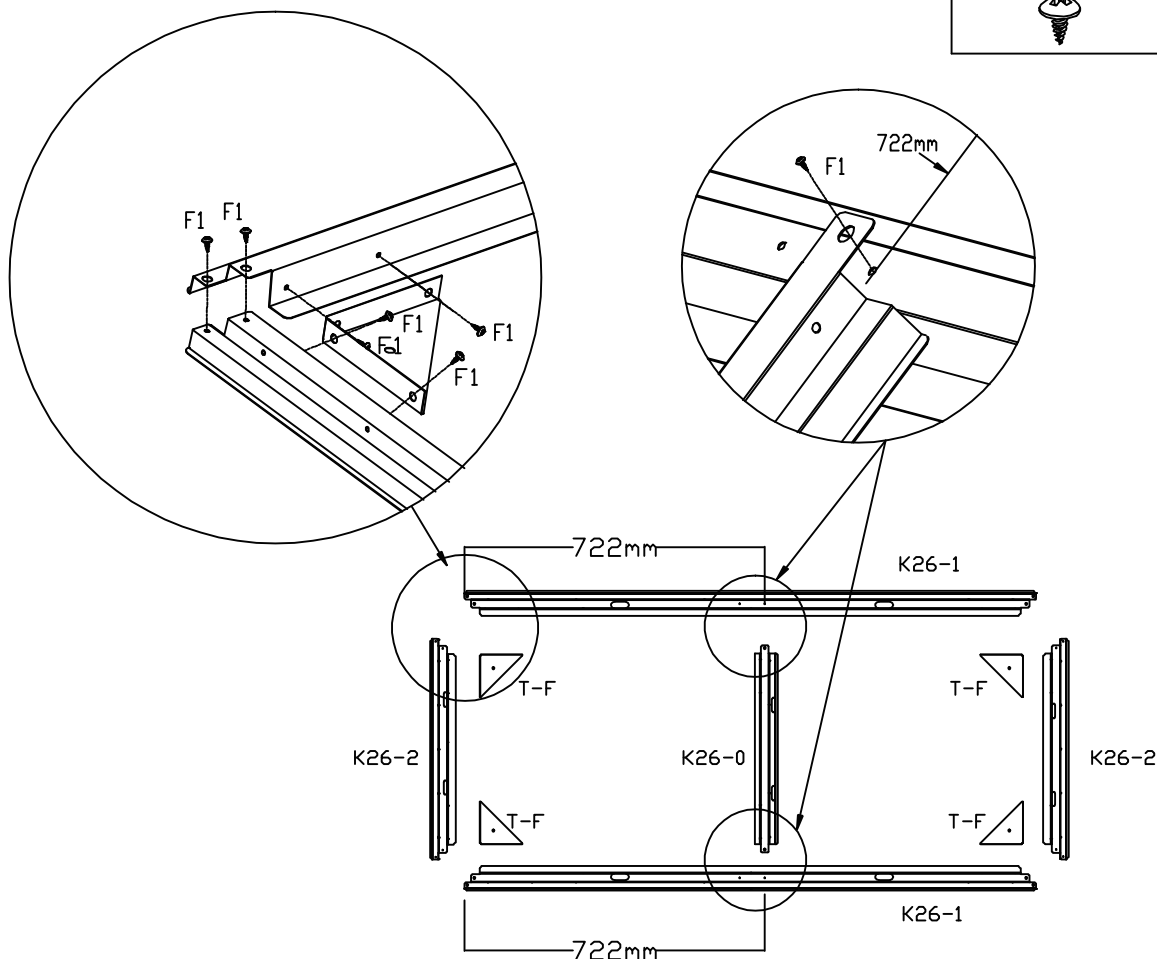

Attention: Install according to size 722mm, insallation error will prevent subsequent installation!

PART	NO.	QTY.
	K26-0	1
	K26-1	2
	K26-2	2
	T-F	4
	F1	26

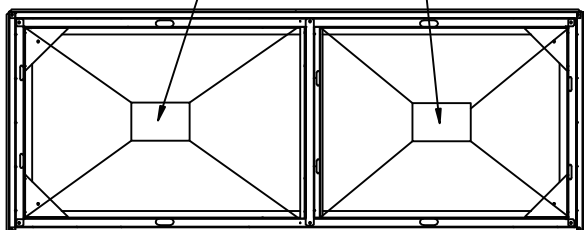

The base is a docking structure, and the diagonal dimensions need to be consistent during assembly, with a flat ground, otherwise it will affect the entire tool room structure.



PART	NO.	QTY.
 K23W3-C	K23W3-C	2
 K26W3-CL	K26W3-CL	1
 K26W3-CR	K26W3-CR	1
 F1	F1	4

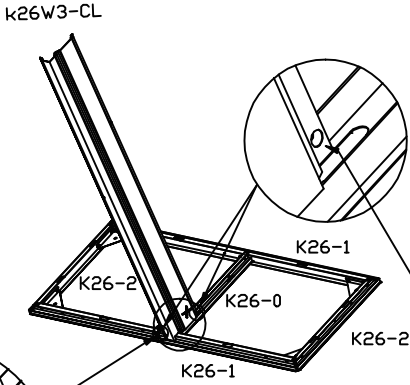
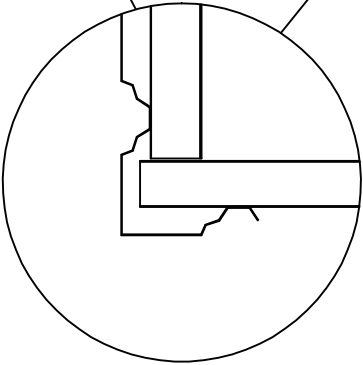
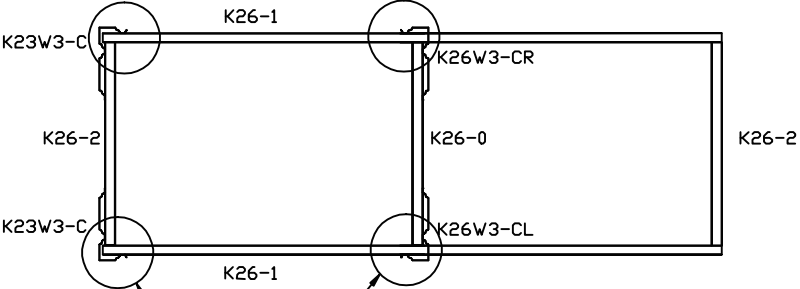

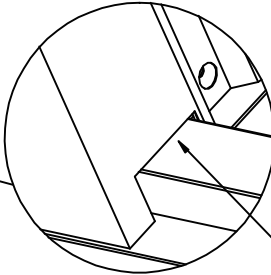
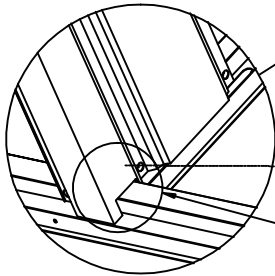

Do not add screws that indicated with an X in diagram These need to be left undone.

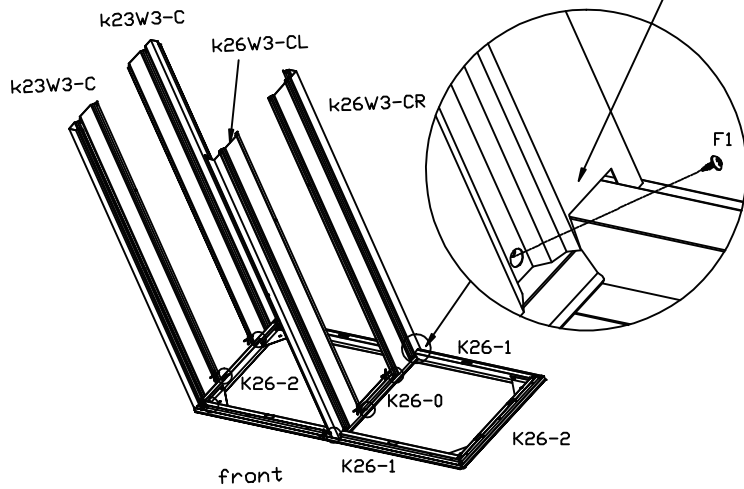

Attention: Install the notch diagram correctly!





PART	NO.	QTY
	K26-3	2
	F1	12
	C2	4

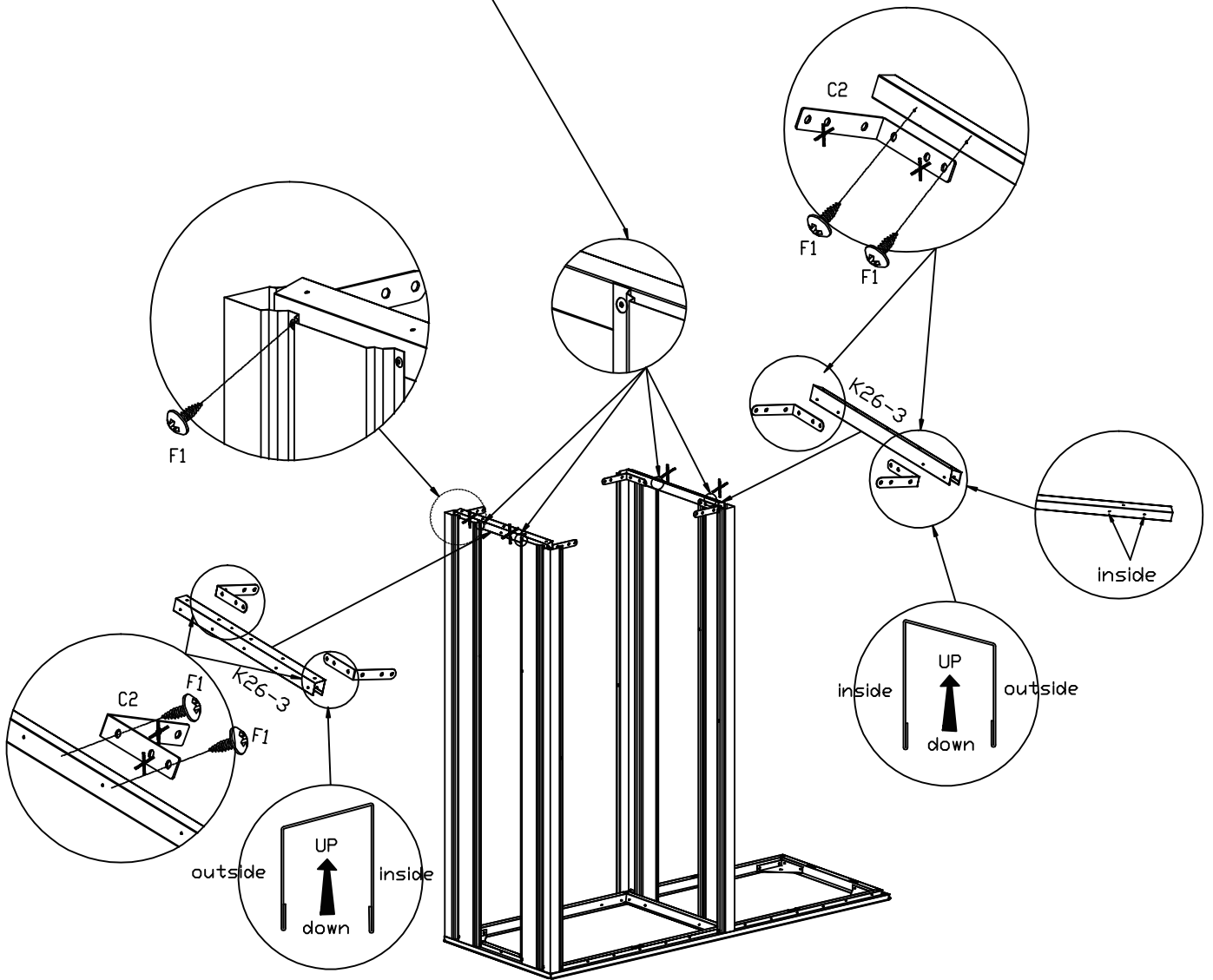

Do not add screws that indicated with an X in diagram These need to be left undone.



Top Panel Assemble

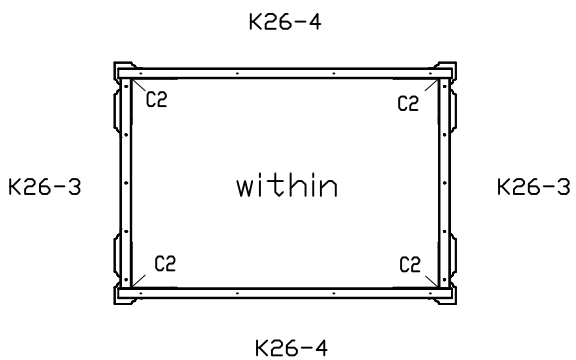
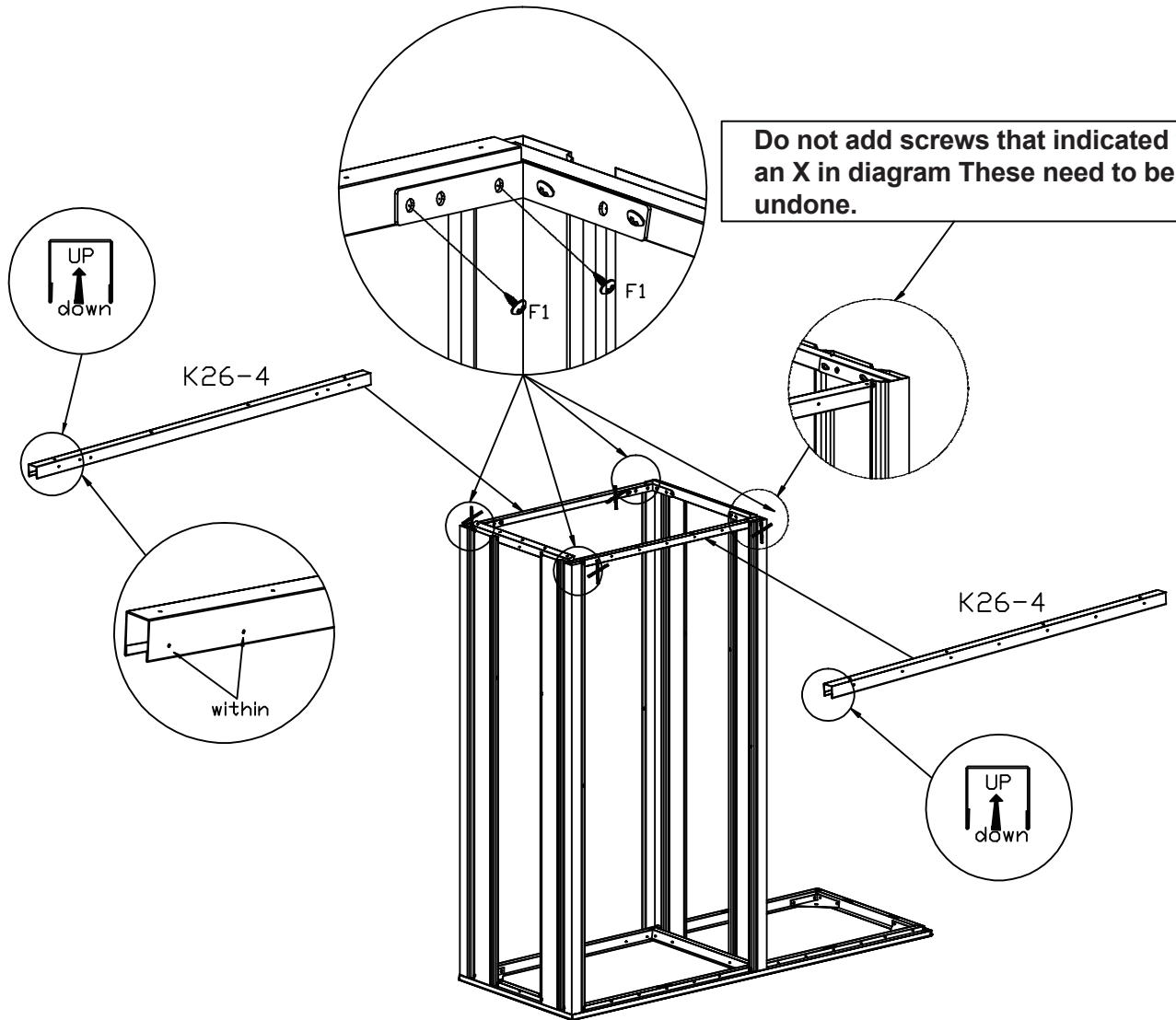



PART	NO.	QTY
	K26-4	2
	F1	8

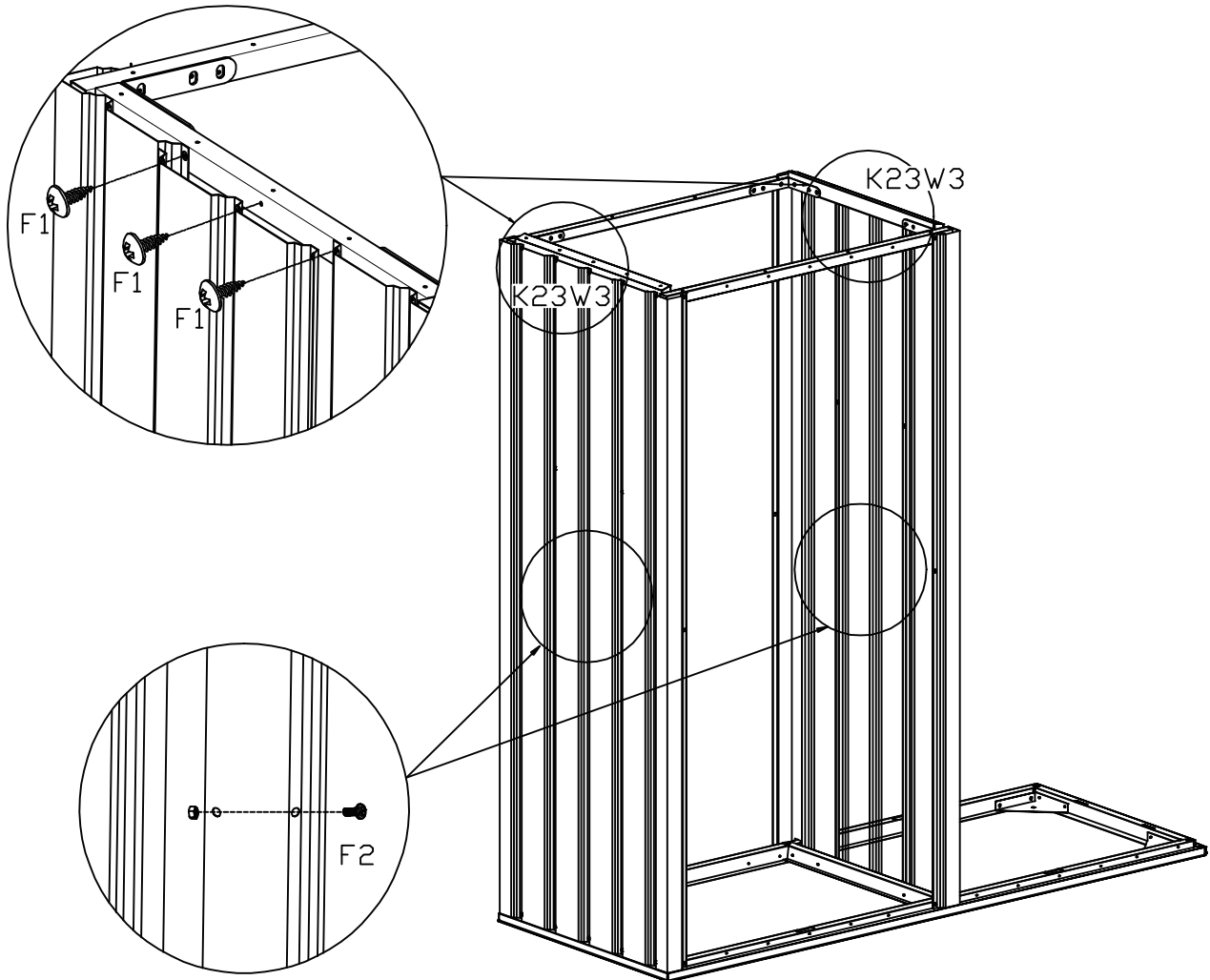
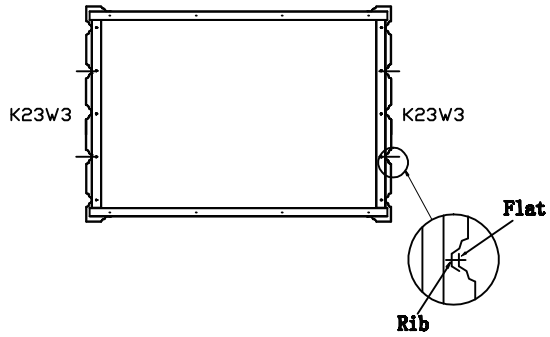

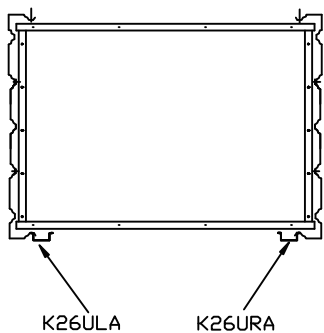
PART	NO.	QTY.
	K23W3	2
	F1	12
	F2	4





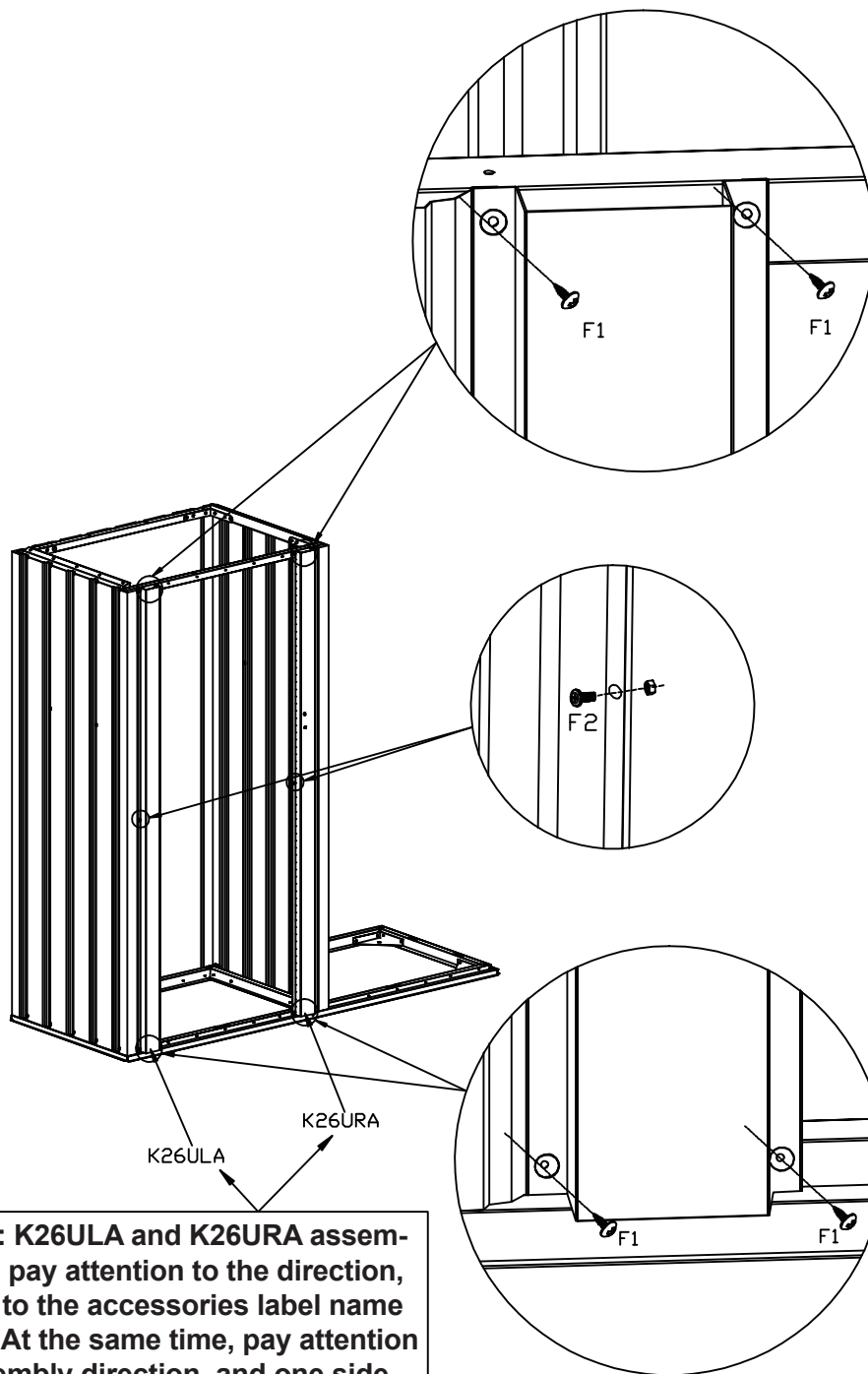

PART	NO.	QTY.
	K26ULA	1
	K26URA	1
	F1	8
	F2	2





"Attention: K26ULA and K26URA assembly should pay attention to the direction, according to the accessories label name assembly. At the same time, pay attention to the assembly direction, and one side with holes in the middle is matched with the hole in the grain plate."



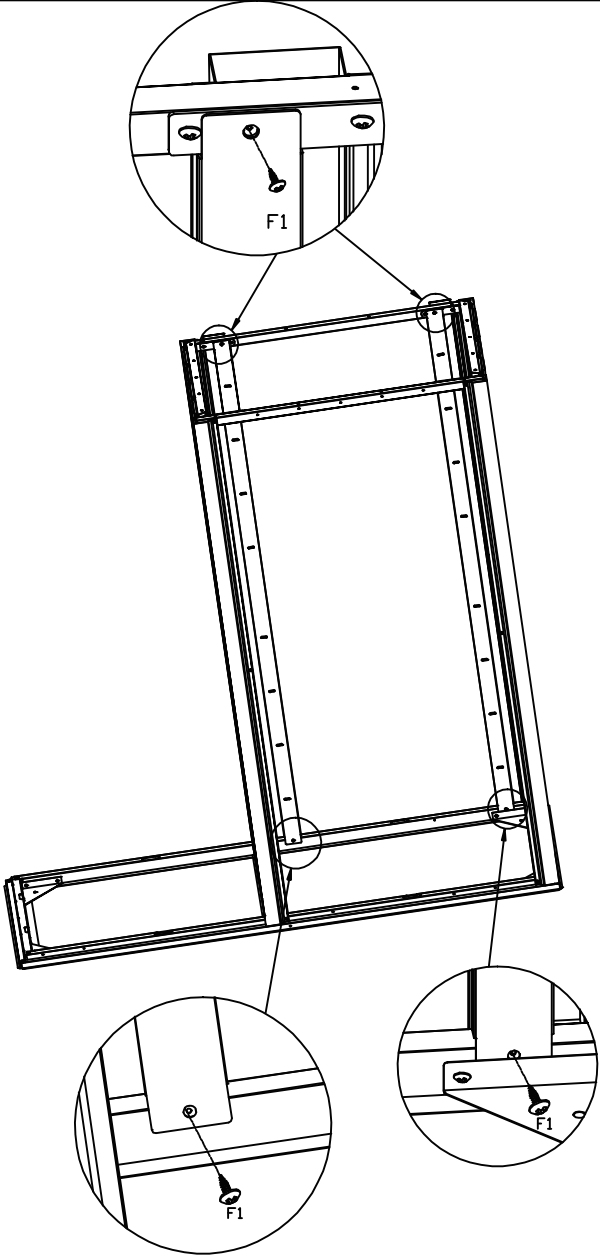

PART	NO.	QTY.
	K26-12	2
	F1	4

Attention: K26-12 should be installed in the corresponding position of K26ULA and K26URA

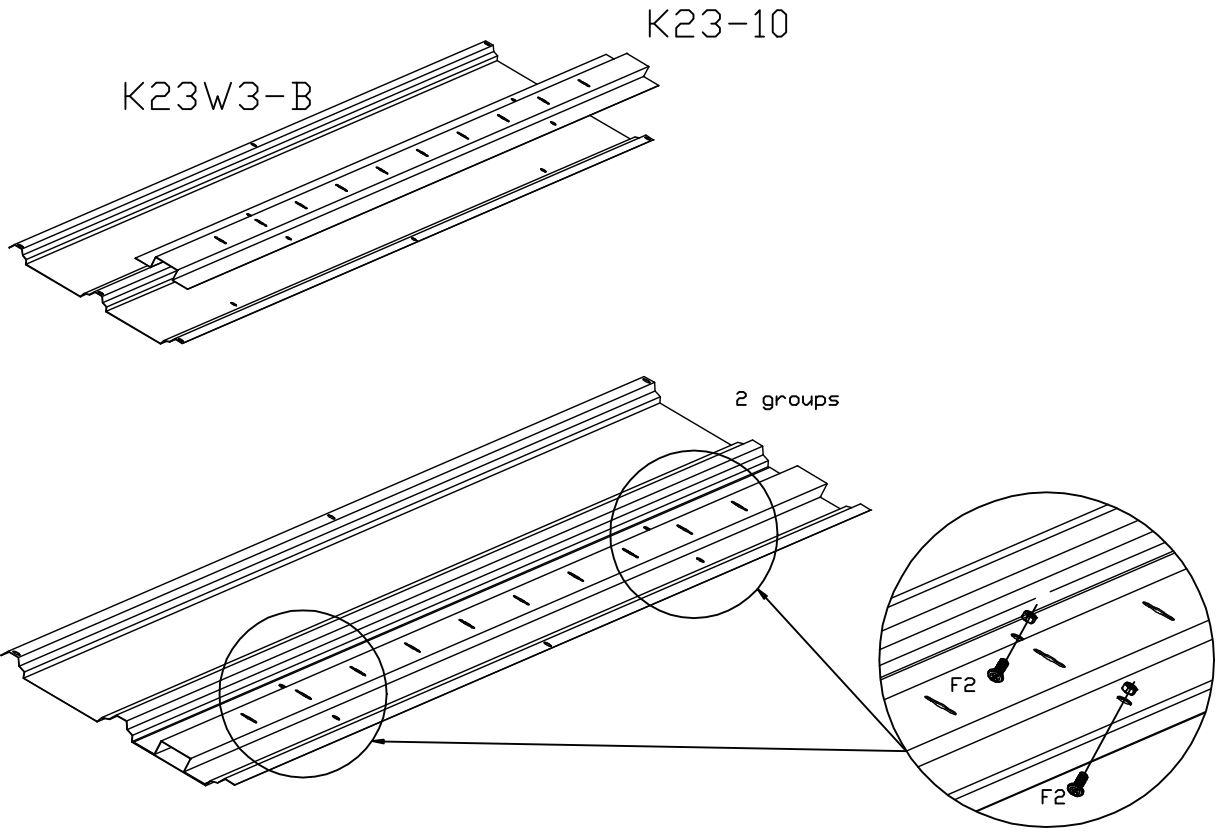

PART	NO.	QTY.
	K23W3-B	2
	K23-10	2
	F2	8





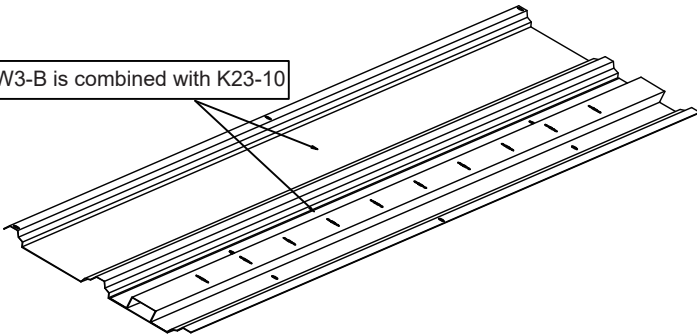

PART	NO.	QTY.
	K23W3	1
	K23W3-B 兼K23-10用	2
	F1	14
	F2	4

K23W3-B is combined with K23-10

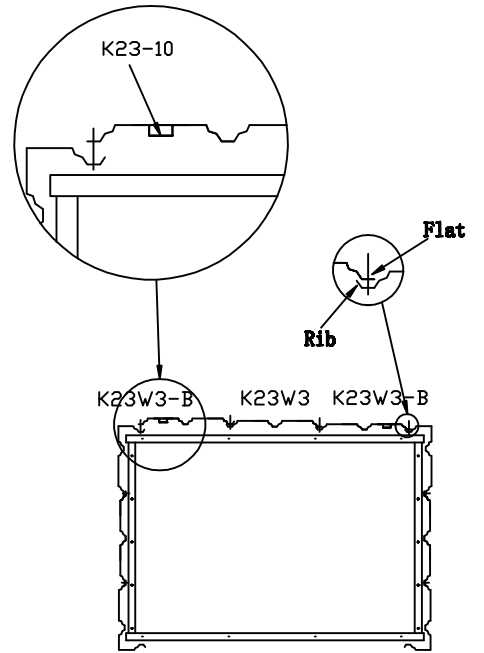
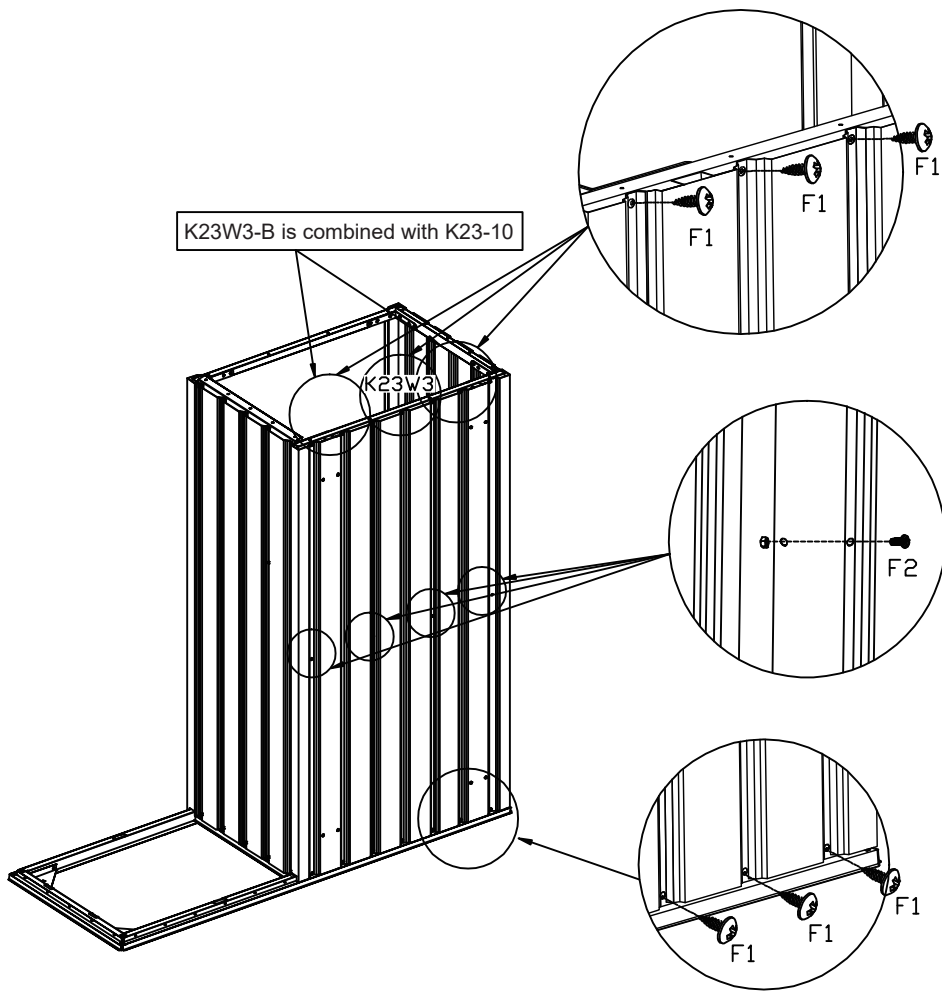



K23W3-B is combined with K23-10



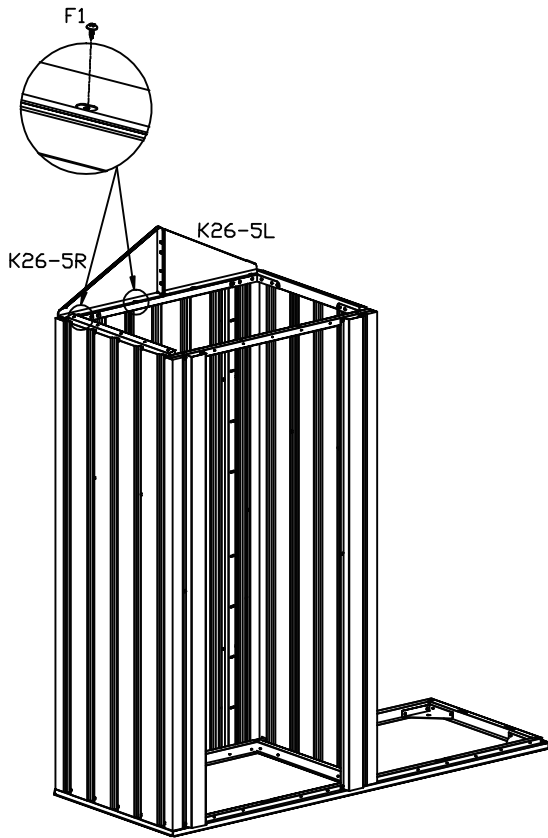
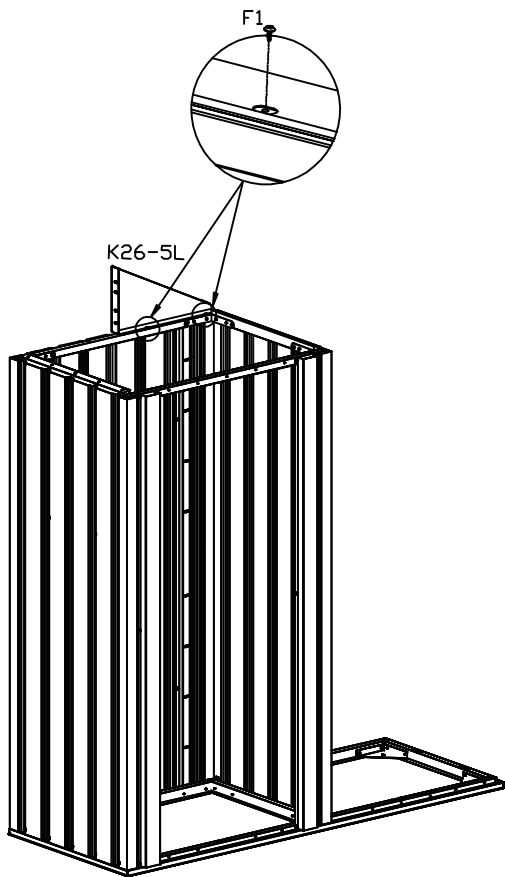

PART	NO.	QTY.
	K26-5L	1
	K26-5R	1
	F1	4



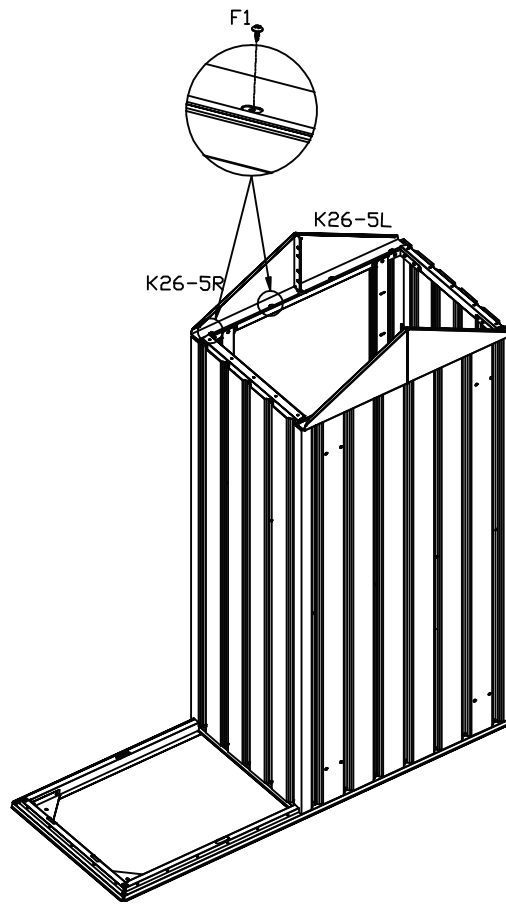
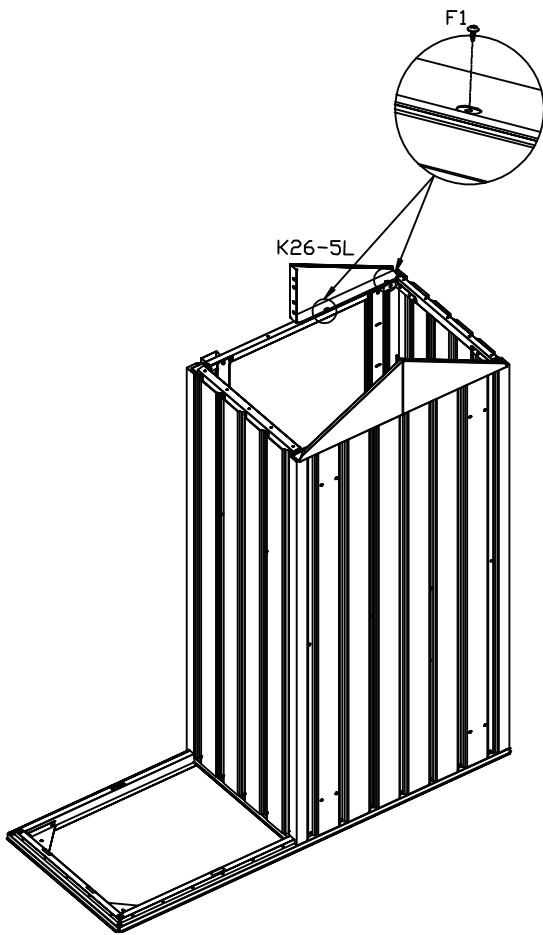

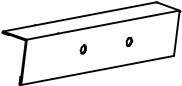
PART	NO.	QTY.
	K26-5L	1
	K26-5R	1
	F1	4



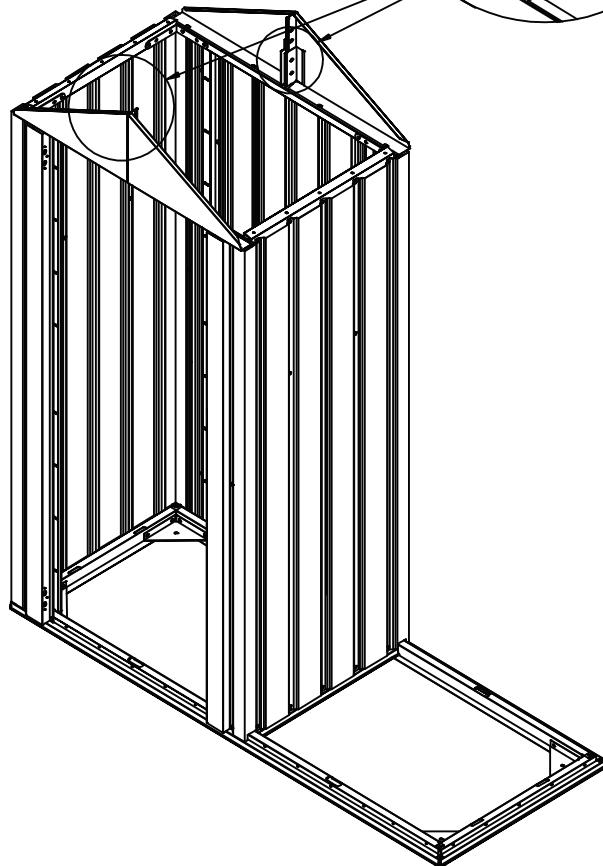
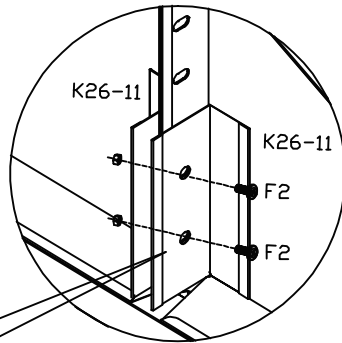
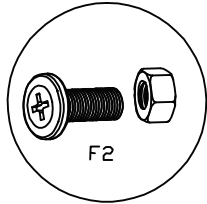





PART	NO.	QTY.
	K26-11	4
	F2	4

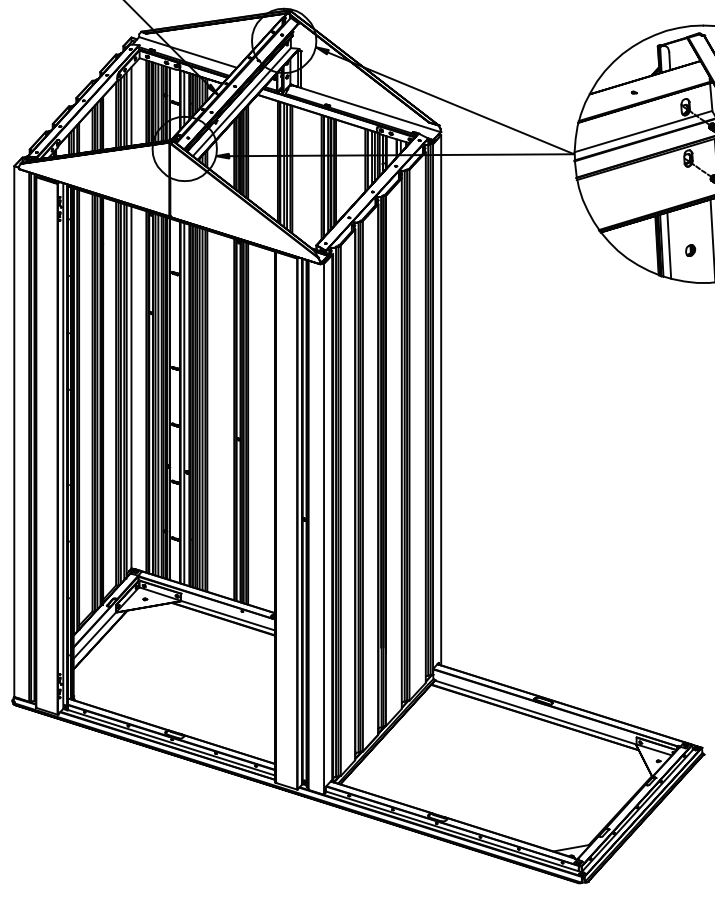
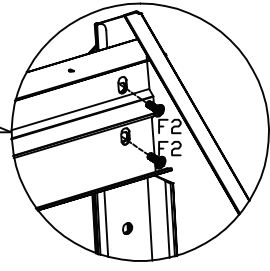
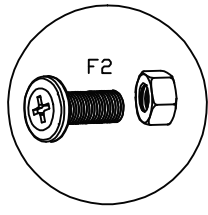
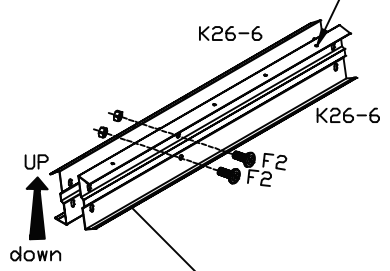

PART	NO.	QTY.
	K26-6	2
	F2	6

Attention: The orientation of the holes is upward



PART	NO.	QTY.
	K26-7L	1
	K26-7M	1
	K26-7R	1
	F1	10
	V2	10

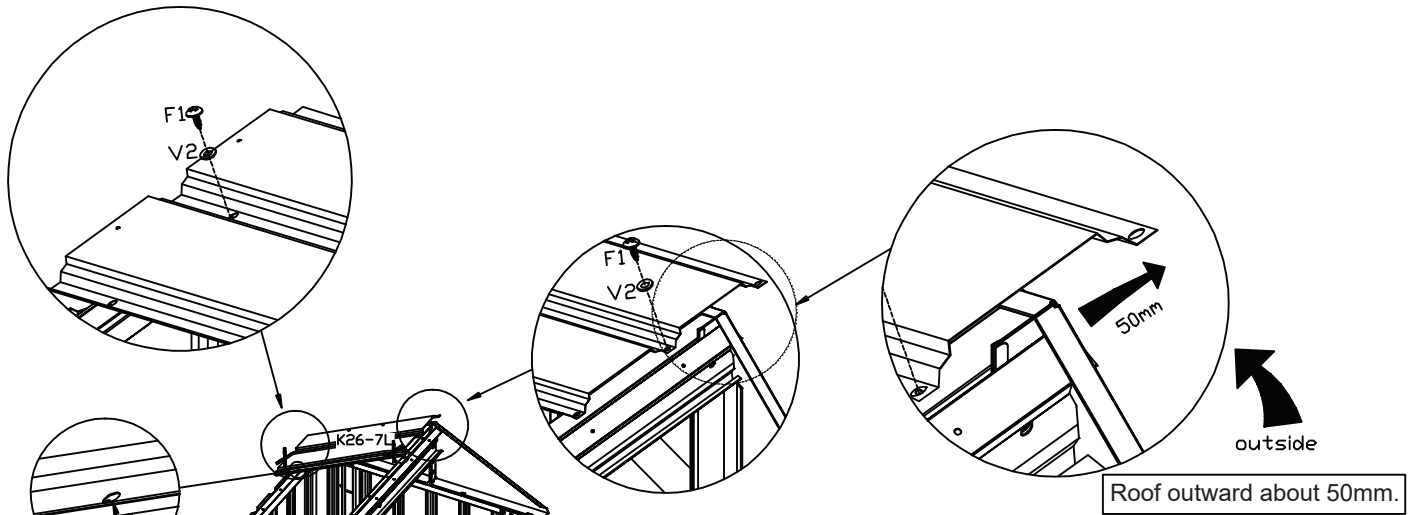
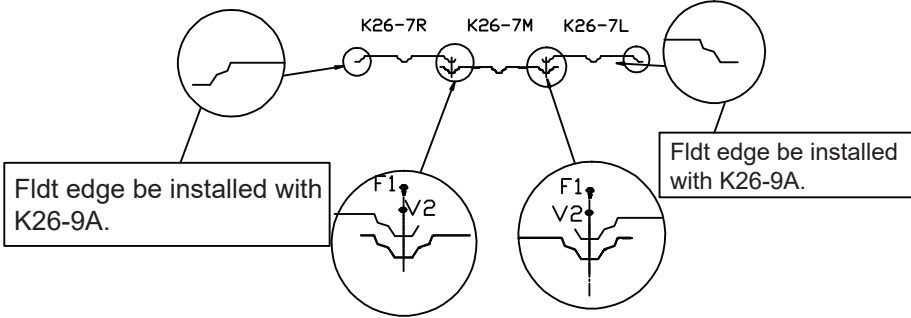





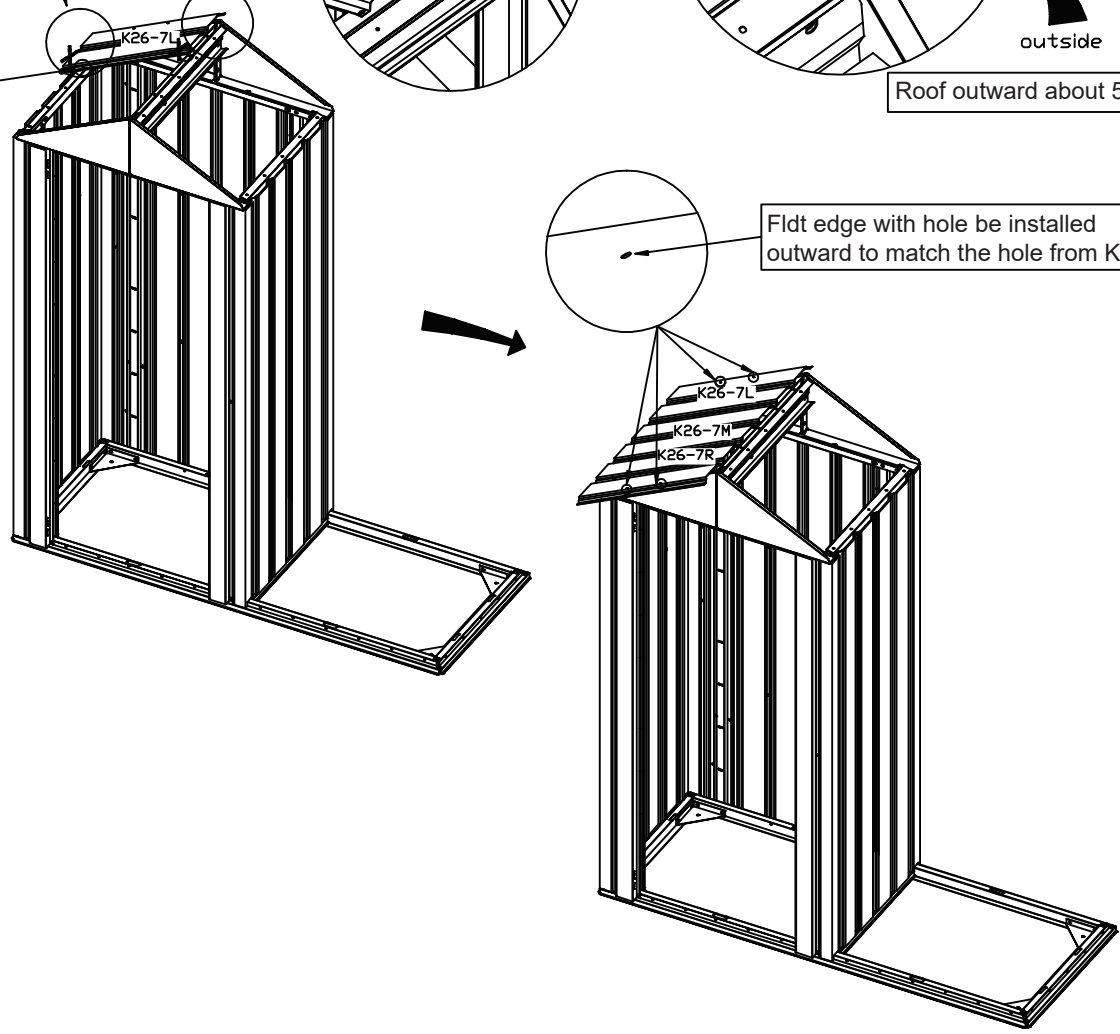

Do not add screws that indicated with an X in diagram These need to be left undone.

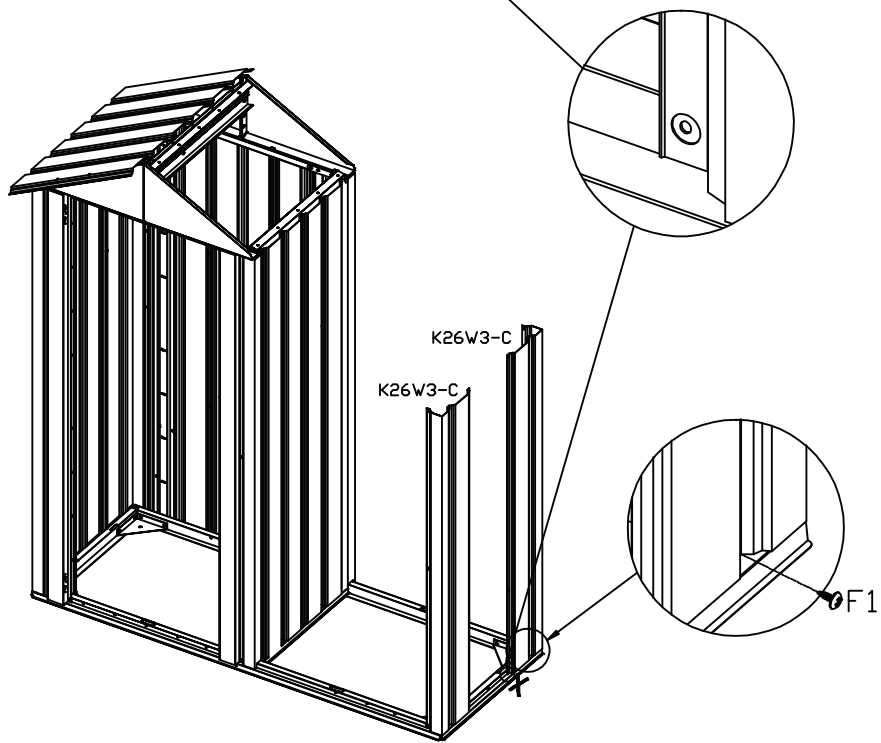
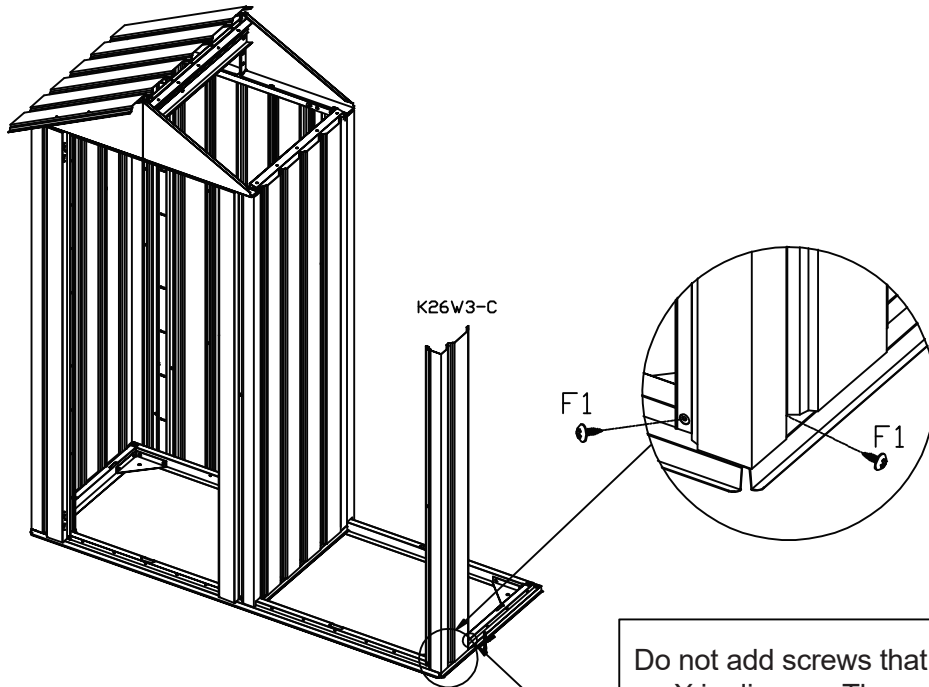
Fldt edge with hole be installed outward to match the hole from K26-9A







PART	NO.	QTY.
	K26W3-C	2
	F1	4

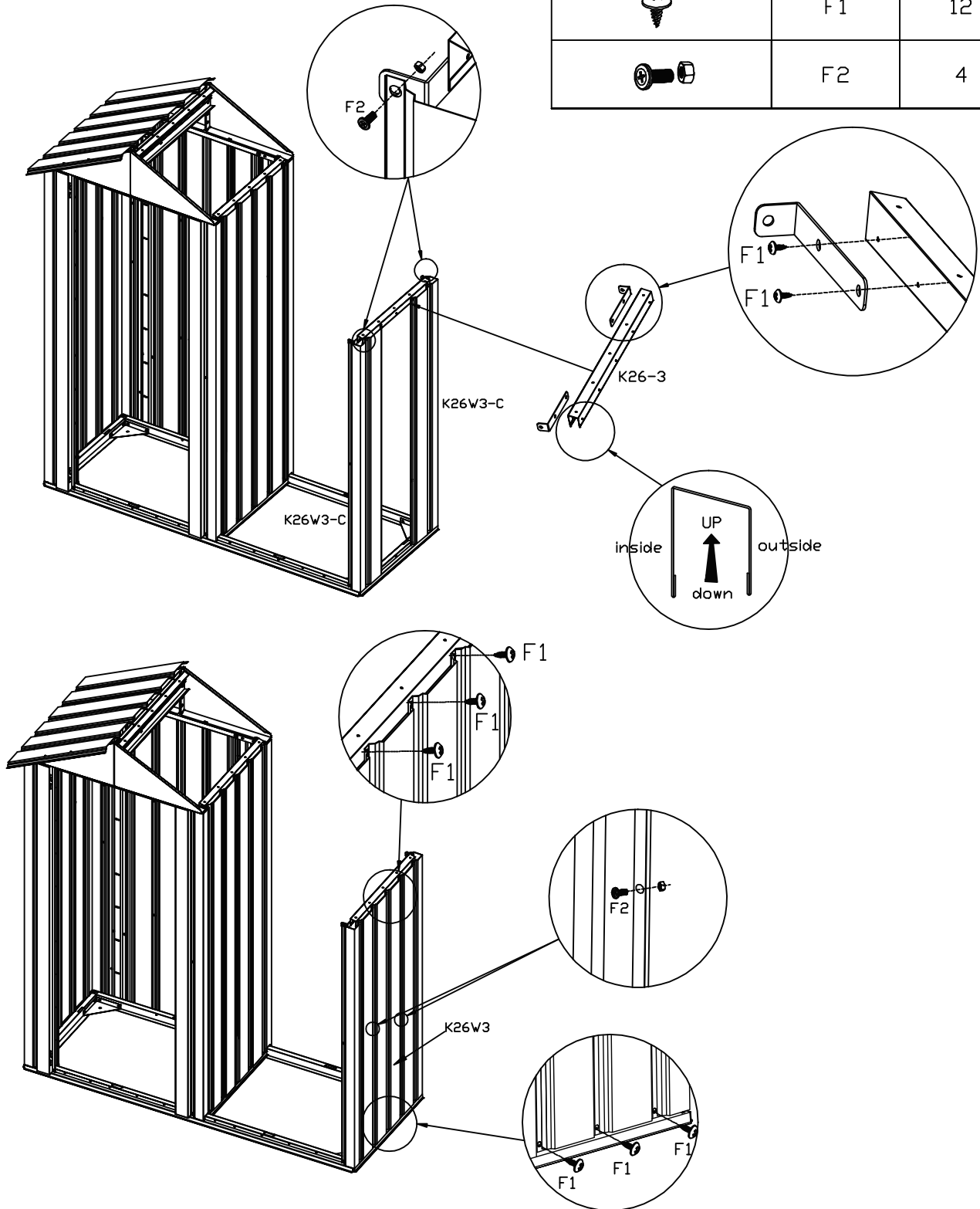



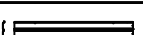



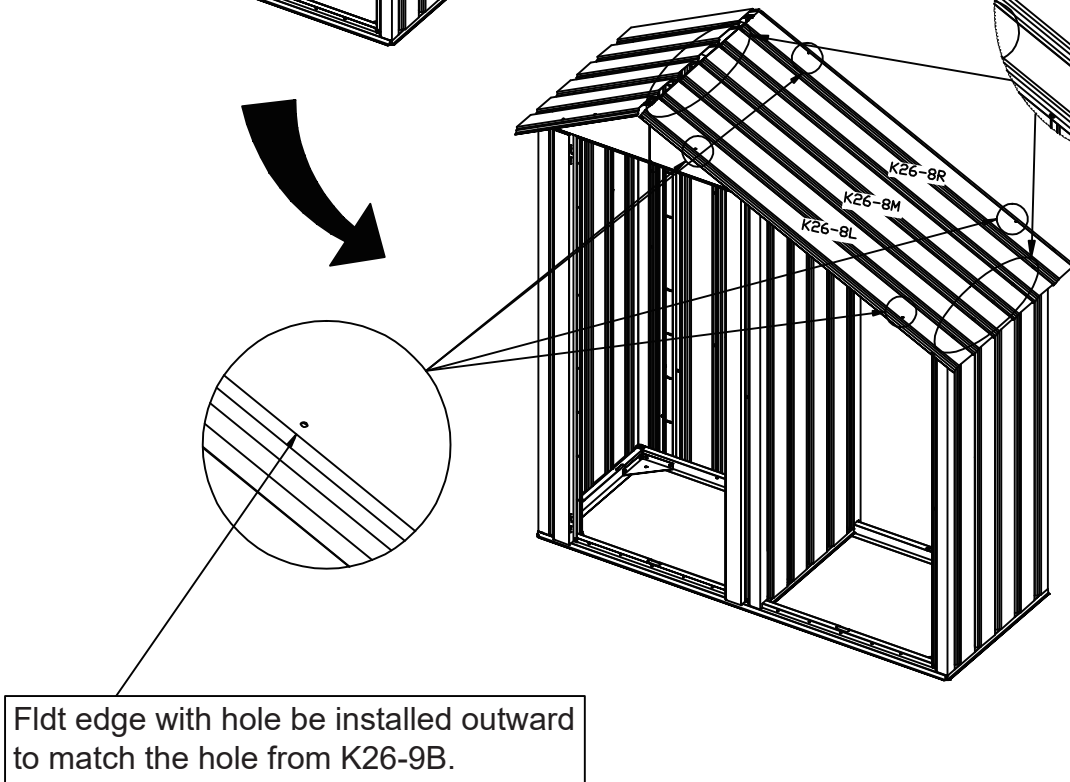
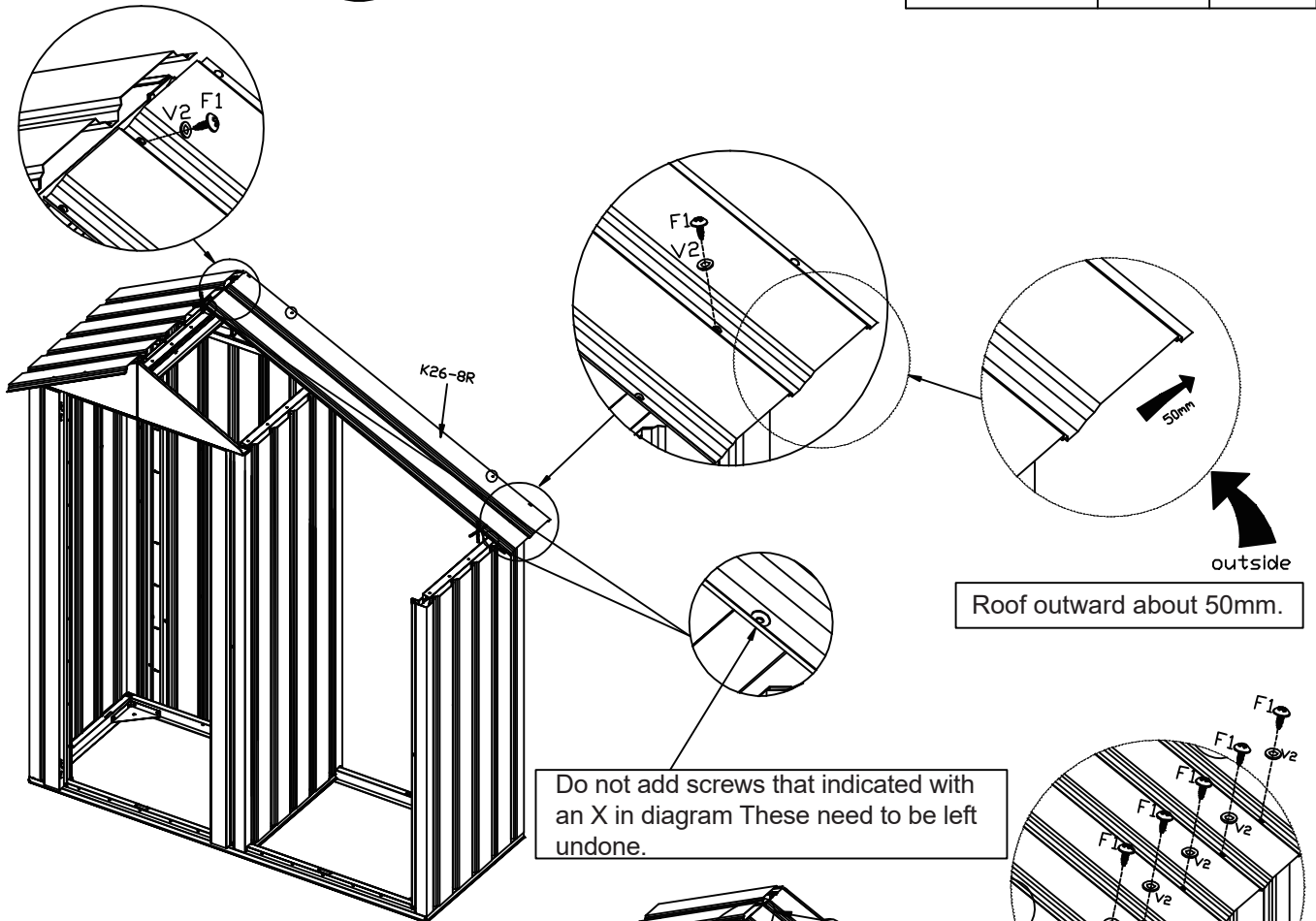
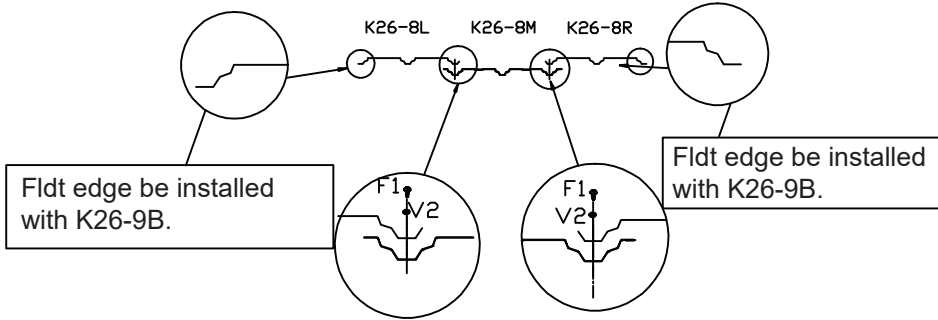

PART	NO.	QTY.
	K26W3	1
	K26-3	1
	C2-2	2
	F1	12
	F2	4





PART	NO.	QTY.
	K26-8L	1
	K26-8M	1
	K26-8R	1
	F1	10
	V2	10

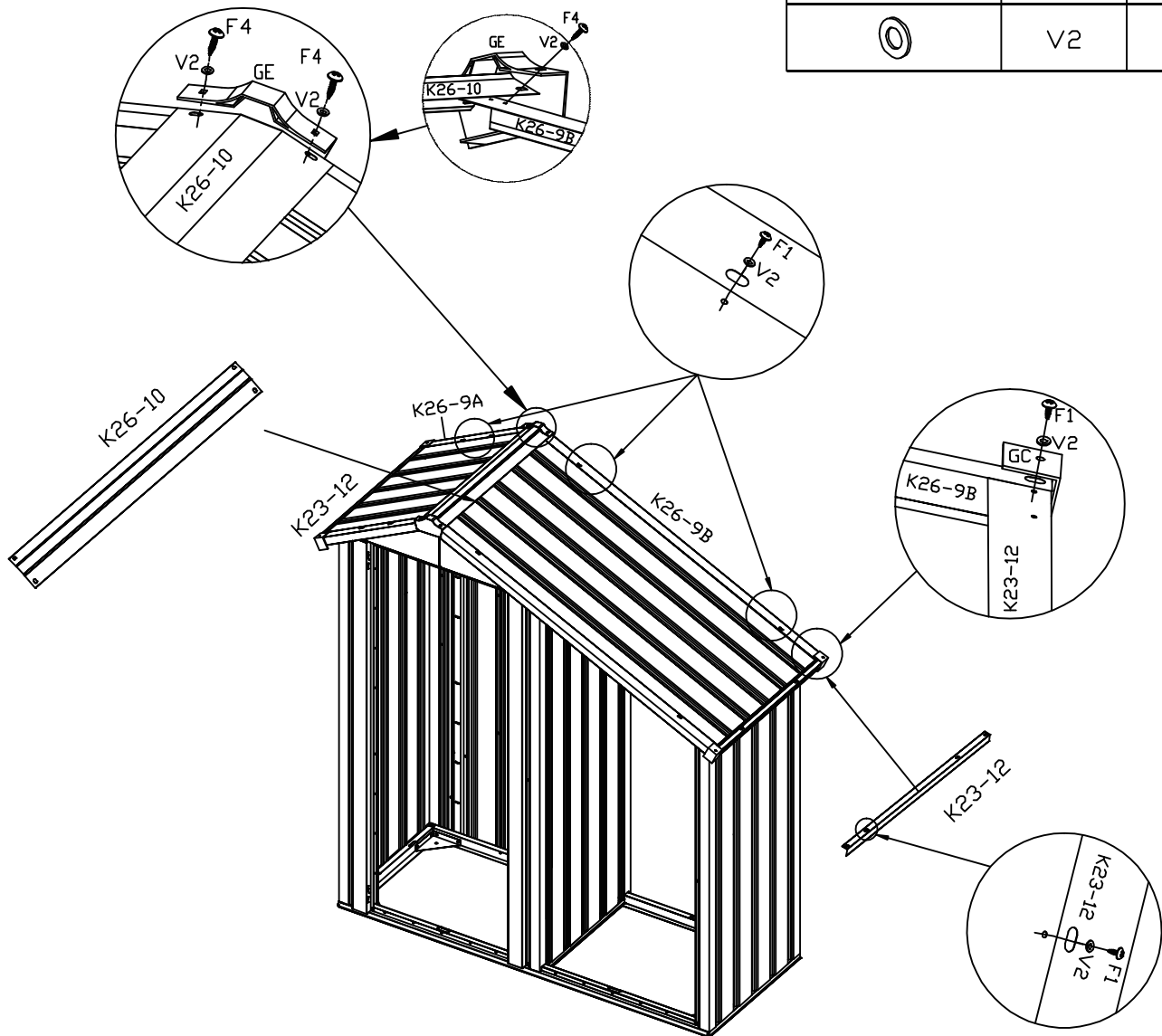
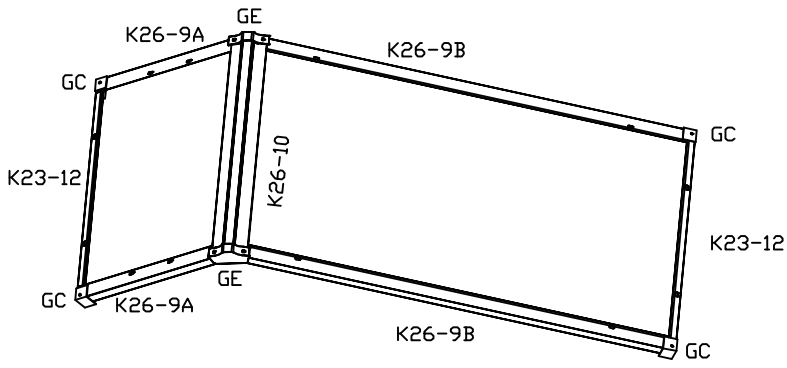

PART	NO.	QTY.
	K26-9A	2
	K26-9B	2
	K23-12	2
	K26-10	1
	GE	2
	GC	4
	F1	16
	F4	4
	V2	16





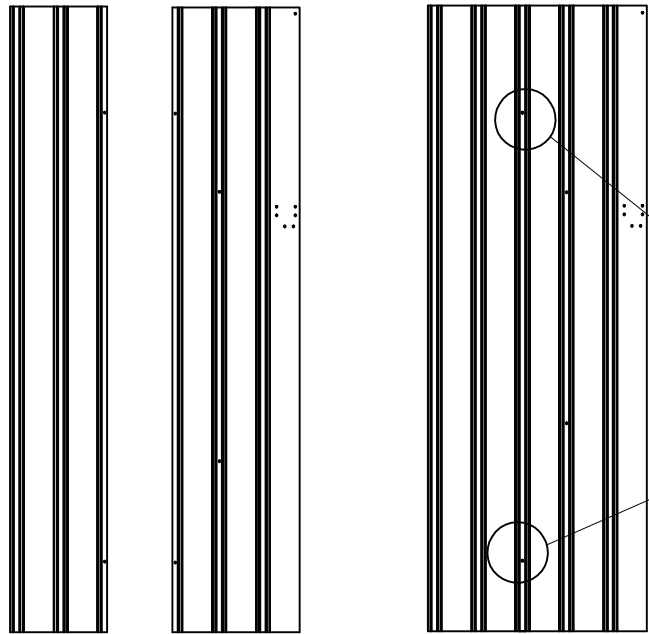

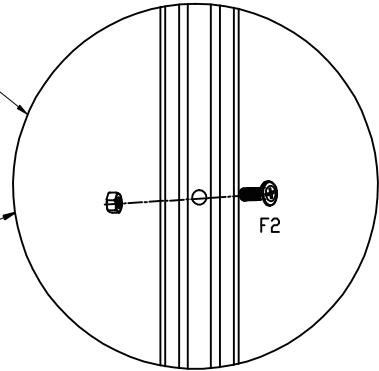

PART	NO.	QTY.
	K23W3-X	1
	K23W3-HX	1
	F2	2



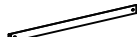



 K23W3-X
  K23W3-HX
  K23W3-X K23W3-HX

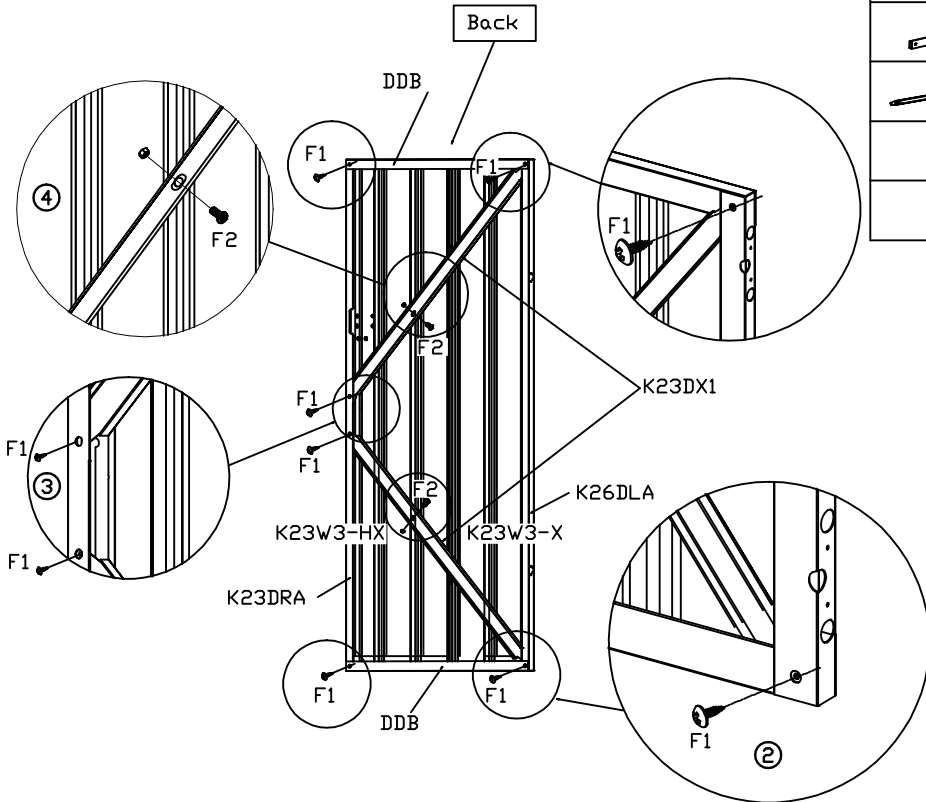



PART	NO.	QTY.
	K26DLA	1
	K23DRA	1
	DDB	2
	K23DX1	2
	F1	10
	F2	2



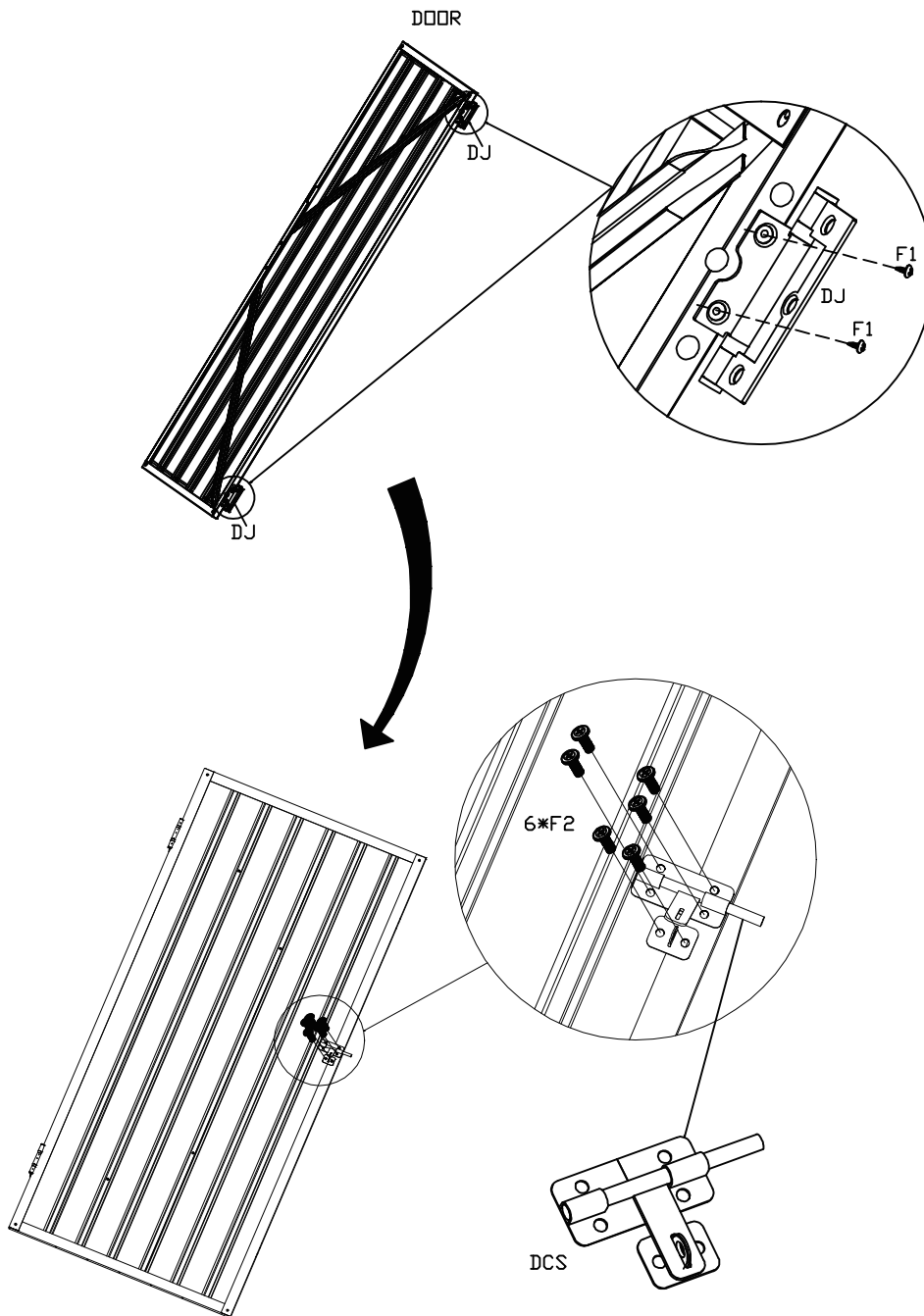

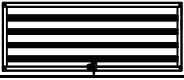
PART	NO.	QTY.
	DCS	1
	DJ	2
	F1	4
	F2	6

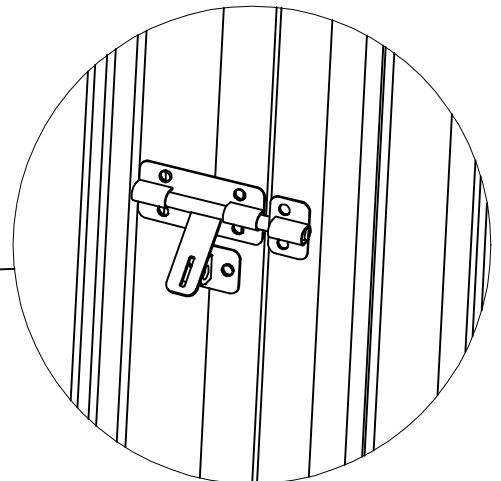
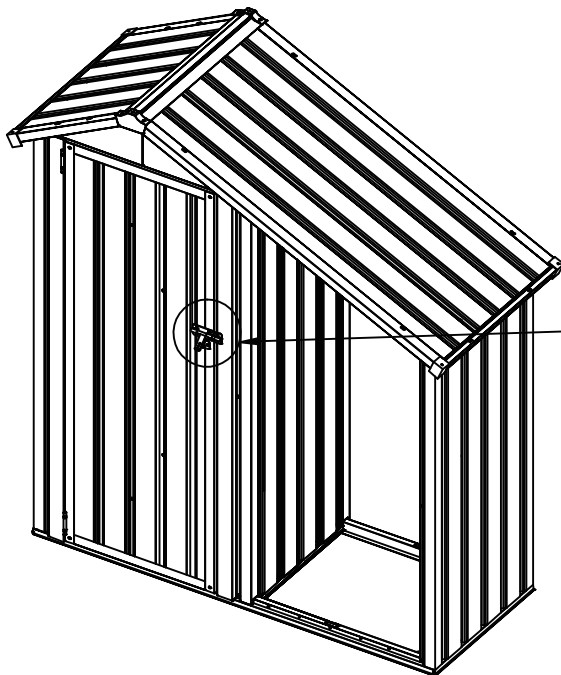
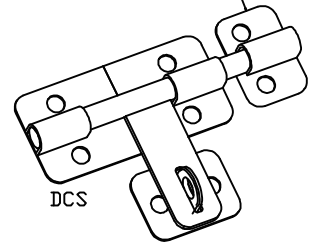
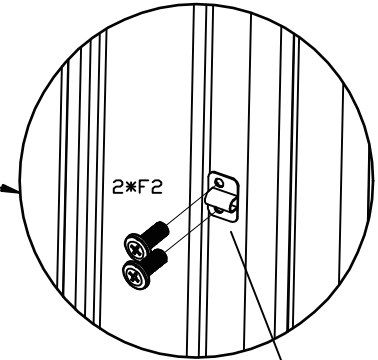
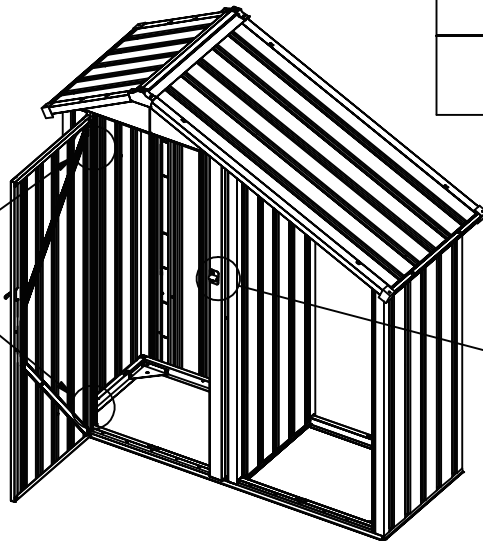
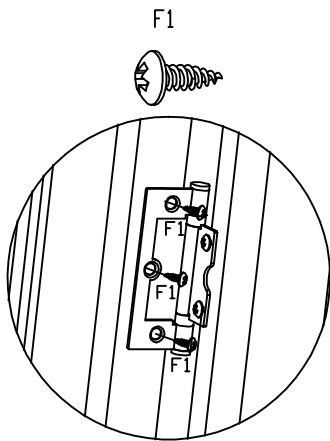

PART	NO.	QTY.
	DOOR	1
	F2	2
	F1	6



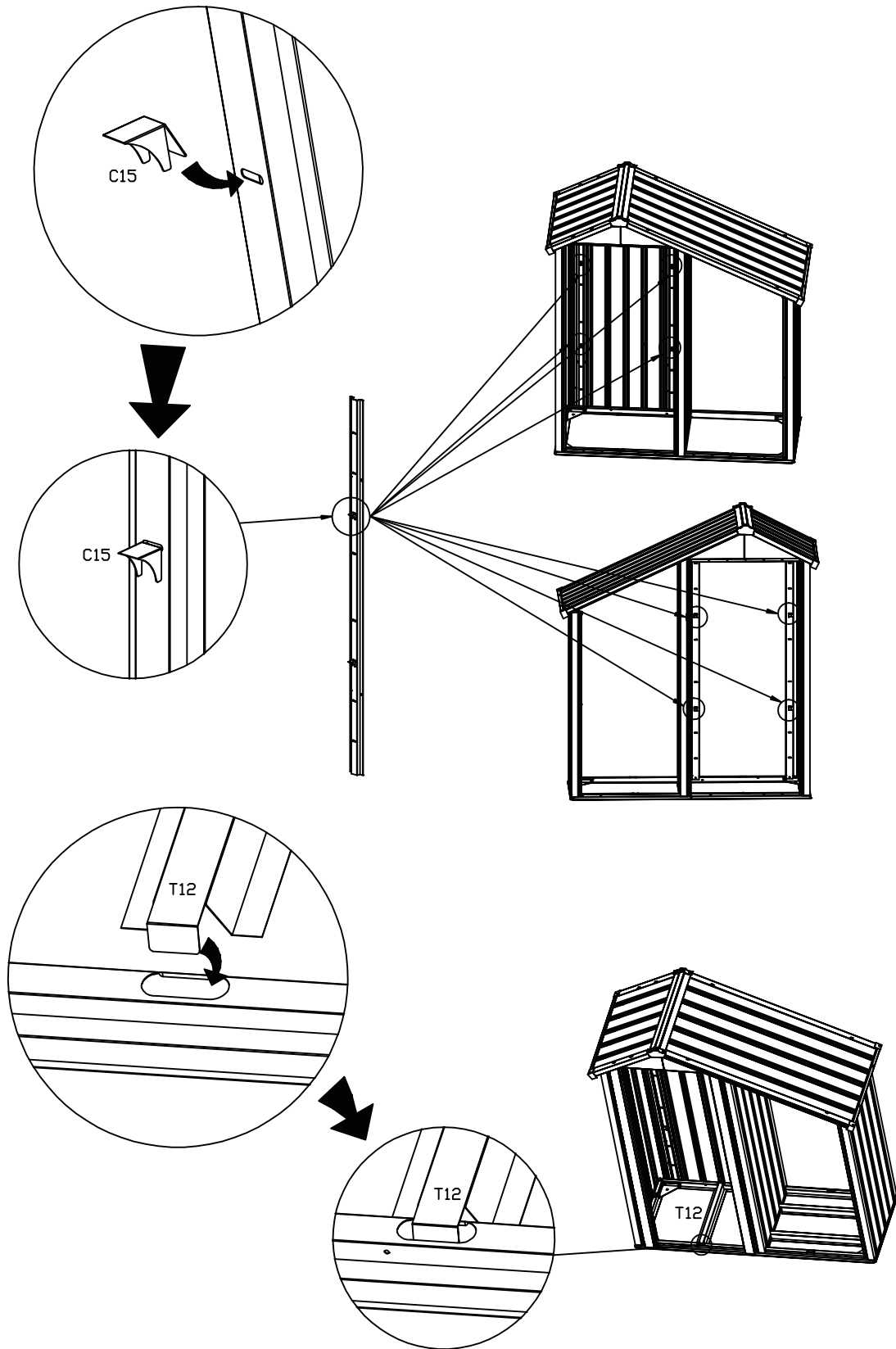

PART	NO.	QTY.
	T12	1
	C15	8

Installation method: Insert C15 into the K23-10 hole.



Installation method: Insert C12 into the K26-1 hole.

PART	NO.	QTY.
	C23-9	6
	C23-8	6
	F1	24

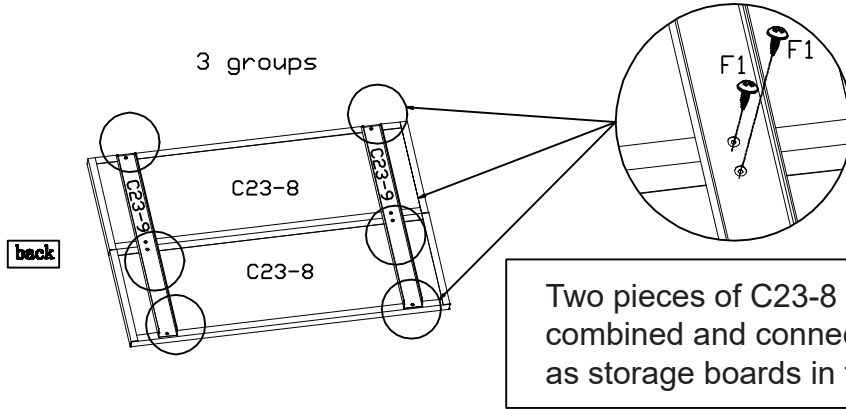

Two pieces of C23-8 and two pieces of C23-9 are combined and connected with F1 self tapping screws as storage boards in the box.

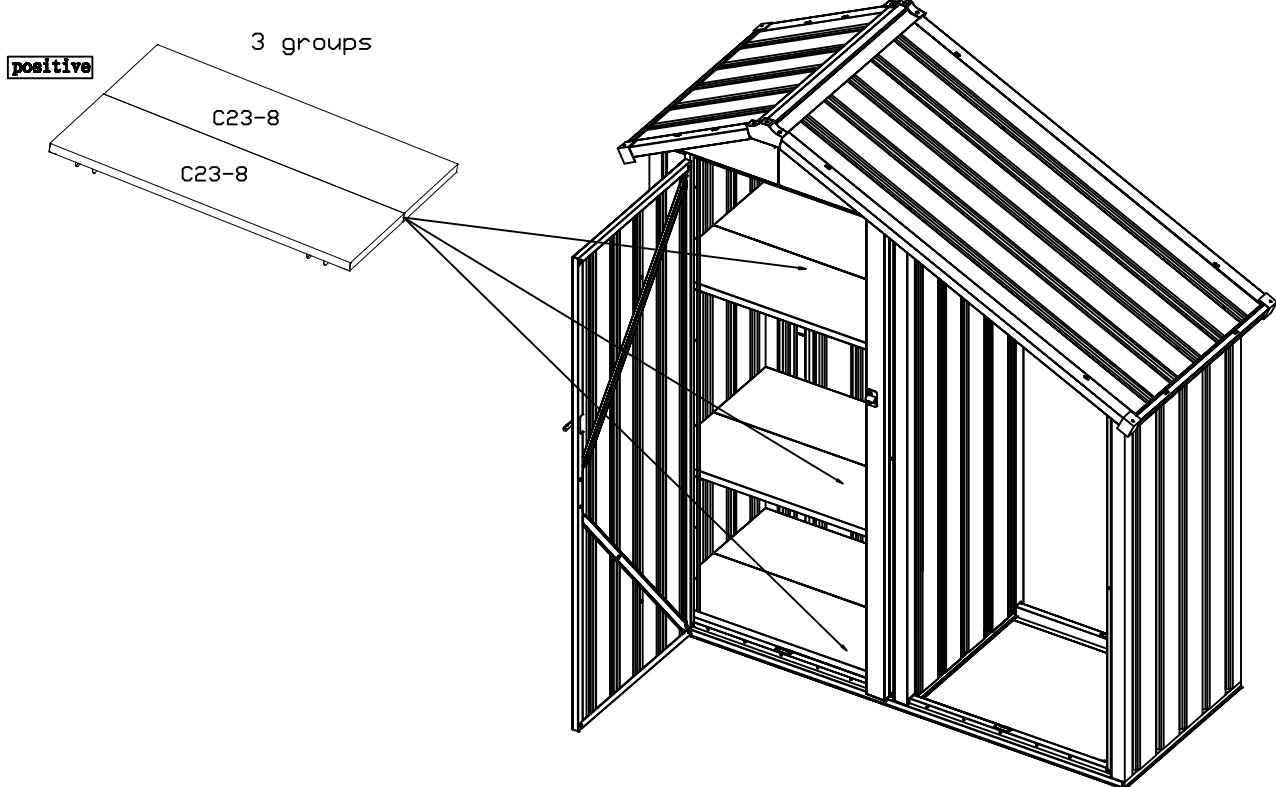

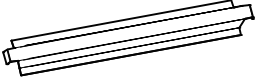
PART	NO.	QTY.
	T22	2

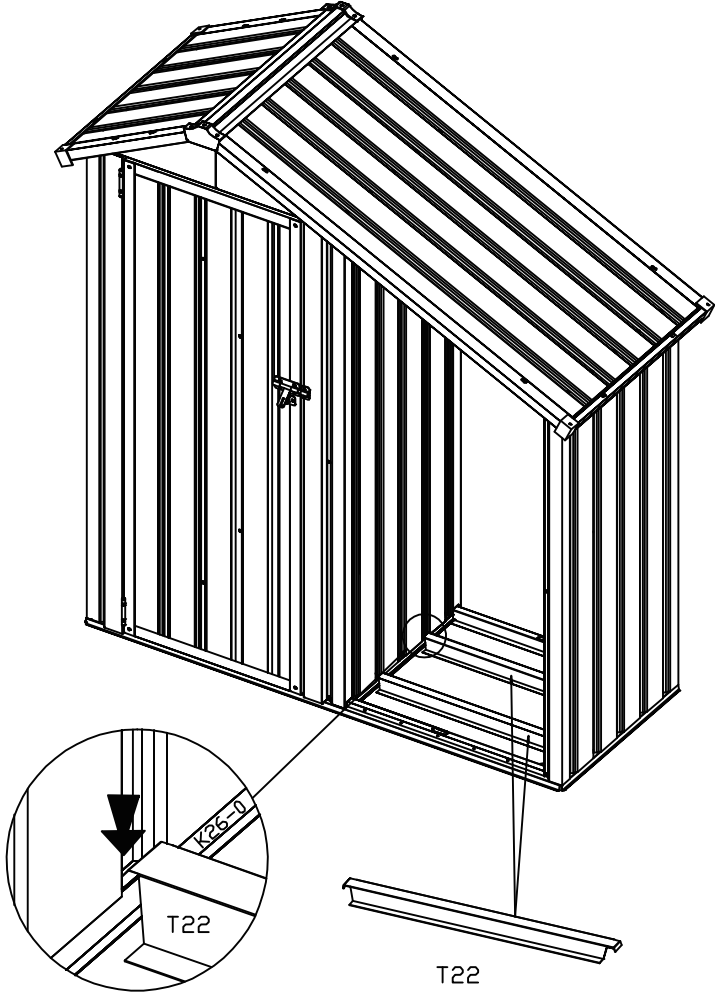

Installation method: Insert T22 into the K26-0 hole.

