

METAL PLATFORM BED FRAME

WARNING!

- Due to the size of this bed we recommend assembling it in the room intended for use.
- Check the packaging to make sure you have all the parts listed on this instruction.
- Before use, make sure this bed is fully assembled. Do not over-tighten screws.
- Do not use power tools to assemble this bed. Additional tools not needed.
- This product should be used only on firm, level ground.
- Do not destroy the packaging until after the product is fully assembled.
- To move this bed, please disassemble firstly.
- This product can support a maximum of 600 lb. evenly distributed.
- Keep all packaging box, bags and small parts out of the reach of children.
- Make sure bed frame's legs are in contact with the ground all the time.
- Do not jump, stand on this bed.

CLEANING INSTRUCTIONS *For: Liquid spills, non-liquid spills*

- The removal of dried non-liquid spills may require the use of soft brush or vacuum.
- Mix water-based upholstery cleaner with 16 ounces of lukewarm water.
- Dampen a cleaning cloth in the mixture and gently blot the soiled area. Avoid rubbing the affected area aggressively.
- Wipe area with a clean cloth dampened in water. Ensure that all the soap residue has been removed.

¡¡¡ADVERTENCIAS!!!

- Debido al tamaño de este producto, le recomendamos ensamblarlo en la habitación donde se piense usar.
- Revise el embalaje para asegurarse de que tiene todas las partes enlistadas en estas instrucciones.
- Antes de usar esta cama, asegúrese de que esté totalmente armada. No apriete de más los tornillos.
- No use herramientas eléctricas para armar esta cama. No se requieren herramientas adicionales.
- Este producto debe usarse solamente sobre un piso firme y parejo.
- No destruya el embalaje antes de que el producto esté completamente armado
- Para mover esta cama, por favor, desármela primero.
- Este producto puede aguantar un máximo de 272 kg distribuidos homogéneamente.
- Mantenga todas las cajas, bolsas y partes pequeñas del embalaje lejos del alcance de los niños.
- Asegúrese de que las patas de la base de la cama estén en contacto con el piso todo el tiempo.
- No salte ni se ponga de pie sobre esta cama.

INSTRUCCIONES DE LIMPIEZA *Para: derrames líquidos, derrames no líquidos*

- Para retirar derrames secos no líquidos se puede requerir el uso de un cepillo suave o aspiradora.
- Mezcle un limpiador de tapicería a base de agua con 473 ml de agua tibia.
- Humedezca un trapo en la mezcla y talle suavemente la zona manchada. Evite tallar agresivamente la zona afectada.
- Limpie la zona con un trapo limpio humedecido en agua. Asegúrese de haber eliminado todo residuo de jabón.

AVERTISSEMENTS!

- En raison des dimensions de ce lit, nous recommandons de le monter dans la pièce prévue pour son utilisation.
- Vérifiez l'emballage afin de vous assurer que vous avez toutes les pièces figurant dans ces instructions.
- Avant l'utilisation, assurez-vous que ce lit est complètement monté. Ne pas trop serrer les vis.
- Ne pas utiliser des outils électriques pour monter ce lit. Des outils supplémentaires ne sont pas nécessaires.
- Ce produit doit être utilisé sur un sol plat et stable uniquement.
- Ne détruisez pas l'emballage avant que le produit ne soit complètement monté.
- Pour déplacer ce lit, veuillez le démonter d'abord.
- Ce produit peut supporter un poids maximal de 272,15 kg distribué de manière égale.
- Gardez la boîte d'emballage, les sacs et les petites pièces hors de la portée des enfants.
- Assurez-vous que les pieds du cadre du lit sont tout le temps en contact avec le sol.
- Ne sautez pas et ne vous mettez pas debout sur ce lit.

INSTRUCTIONS DE NETTOYAGE *Pour : Saleté liquide, saleté non liquide*

- L'enlèvement de saleté non liquide peut exiger l'utilisation d'une brosse douce ou d'un aspirateur.
- Nettoyant pour tissu et rembourrage à base de mélange d'eau avec 500 grammes d'eau tiède.
- Mouillez légèrement un tissu avec le mélange et essuyez doucement la zone sale.
Évitez de frotter la zone à nettoyer de manière forte.
- Essuyez la zone avec un tissu propre imbibé d'eau. Assurez-vous d'enlever tous les résidus de savon.

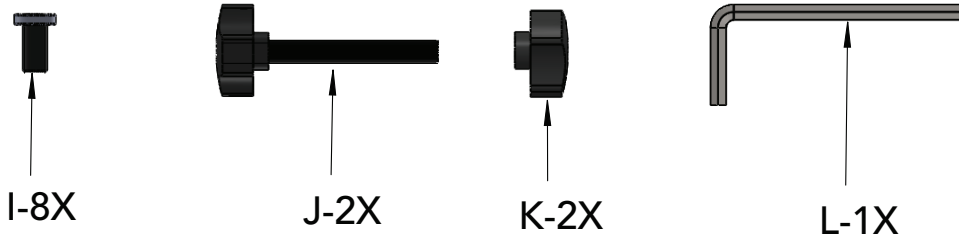
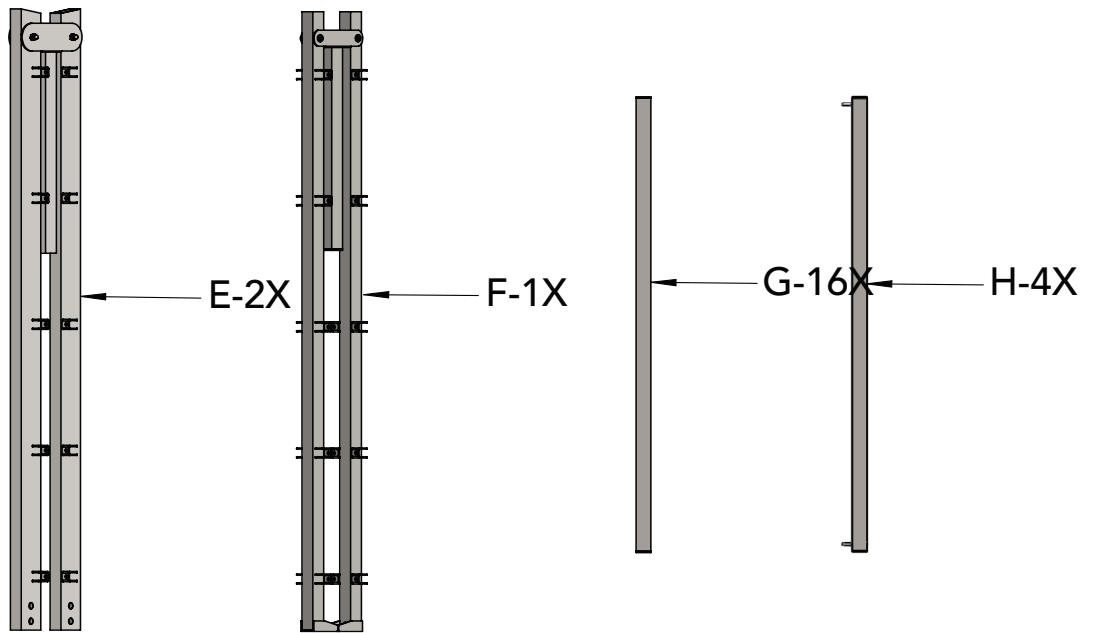
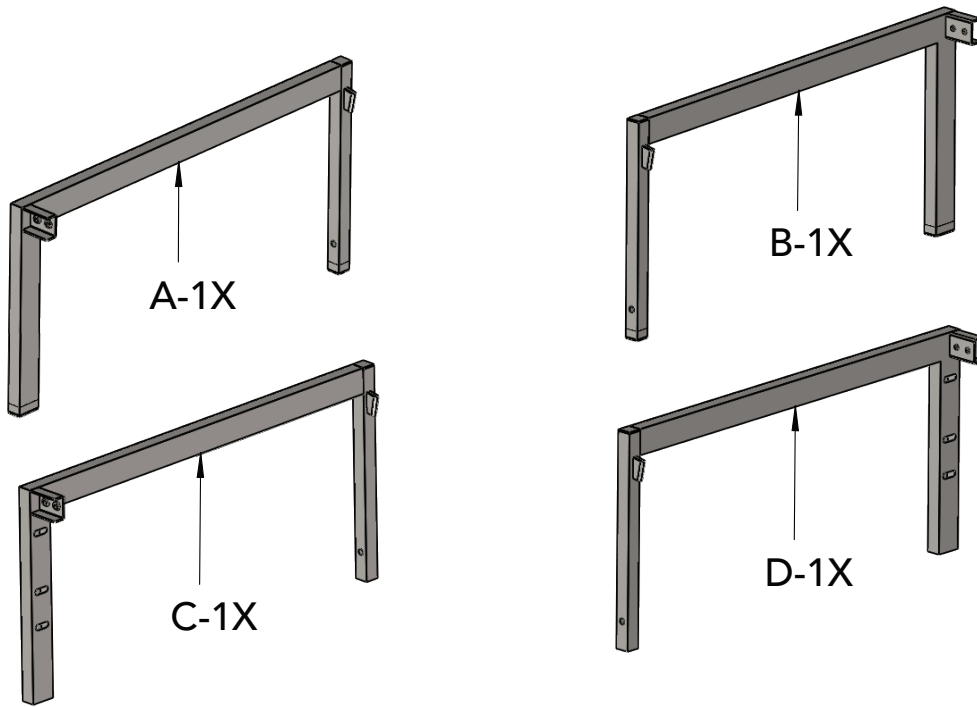

This bed is designed to be used with a box spring.
 Esta cama está diseñada para usarse con un somier.
 Ce lit est conçu pour être utilisé avec un sommier tapissier.

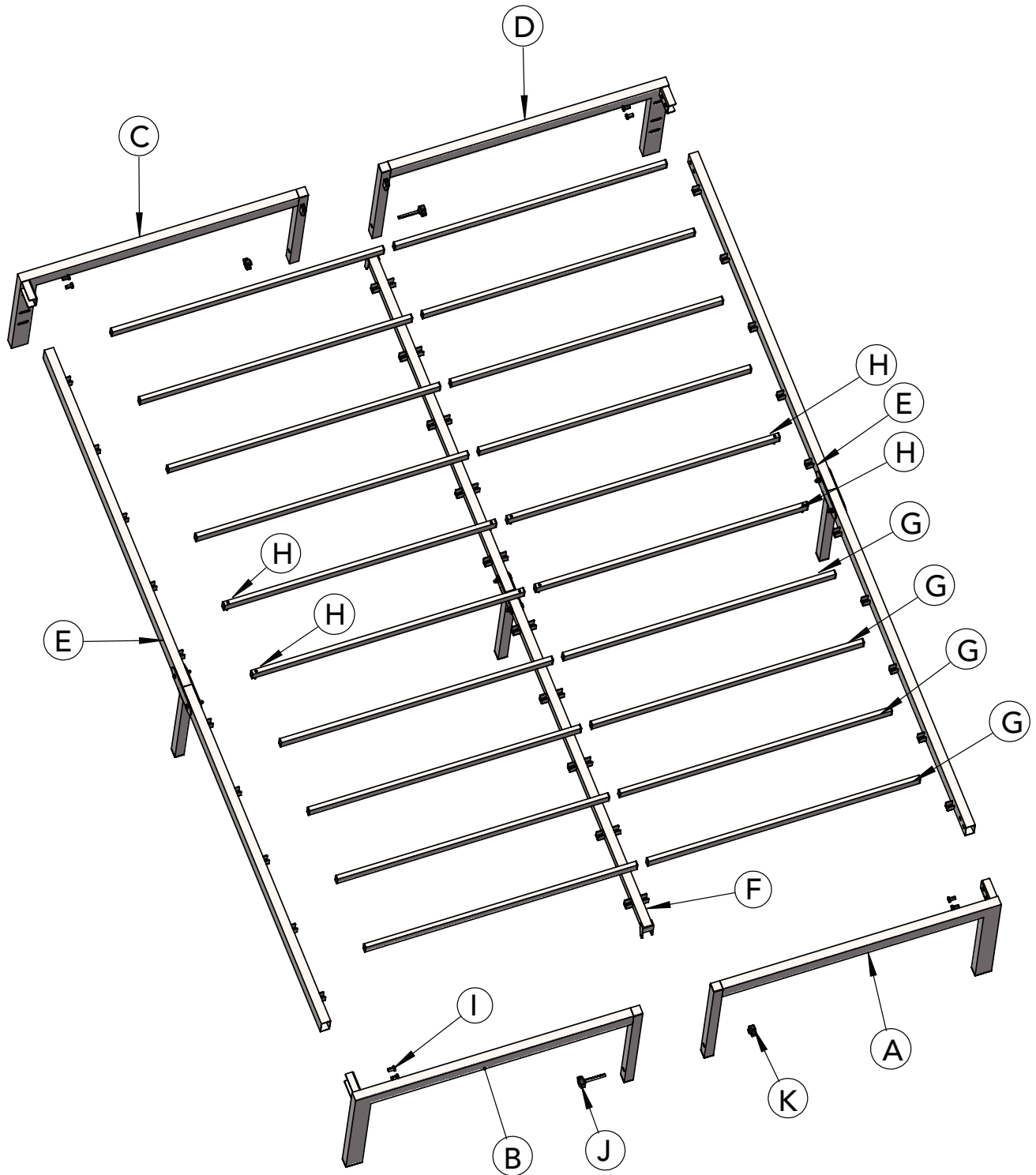

STEP 1

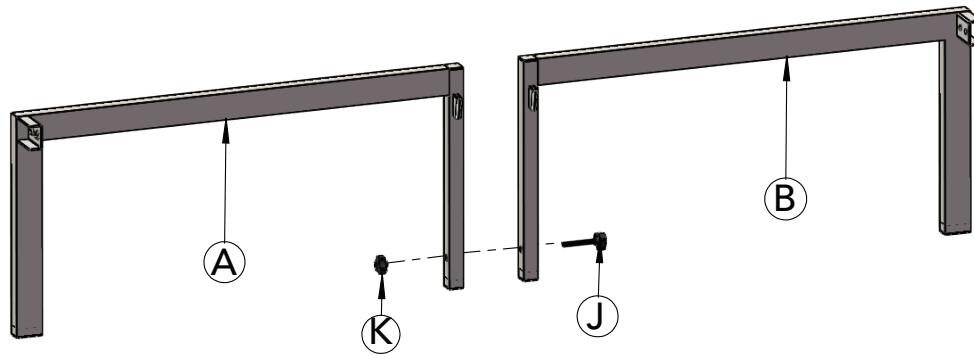

Attach parts (A) and (B) together as shown using bolt (J) and nut (K).
 Una las partes (A) y (B) juntas como se muestra usando el perno (J) y la tuerca (K).
 Assemblez les pièces (A) et (B) comme illustré à l'aide du boulon (J) et de l'écrou (K).

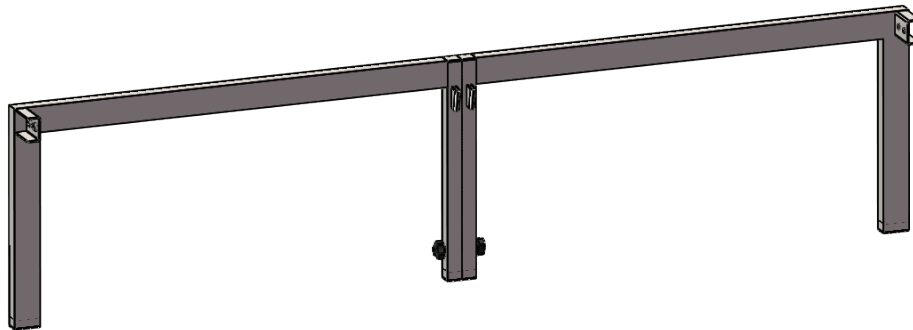

STEP 2

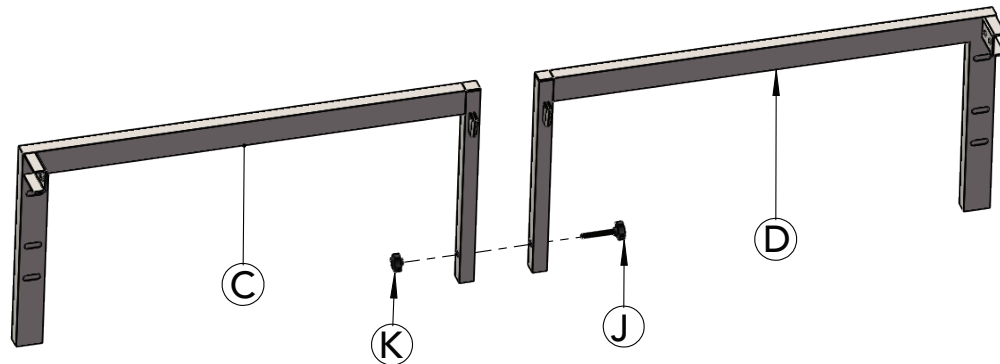

Attach parts (C) and (D) together as shown using bolt (J) and nut (K).
 Una las partes (C) y (D) juntas como se muestra usando el perno (J) y la tuerca (K).
 Assemblez les pièces (C) et (D) comme illustré à l'aide du boulon (J) et de l'écrou (K).

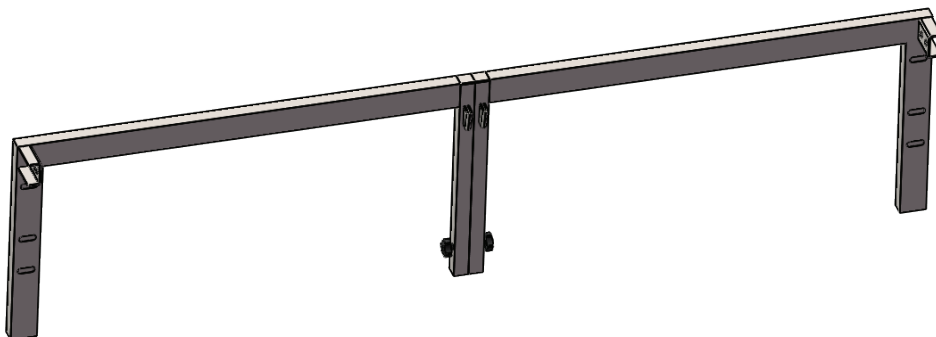

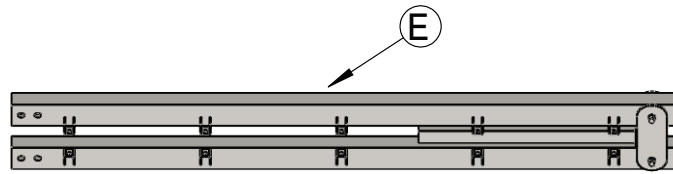
STEP 3

Unfold part (E) as shown, repeat on both parts (E).
Despliegue la parte (E) como se muestra, repita en ambas partes (E).
Dépliez la pièce (E) comme illustré, répétez l'opération sur les deux pièces (E).

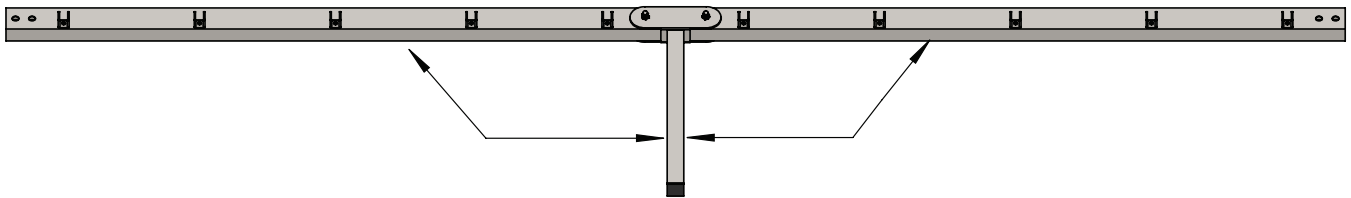
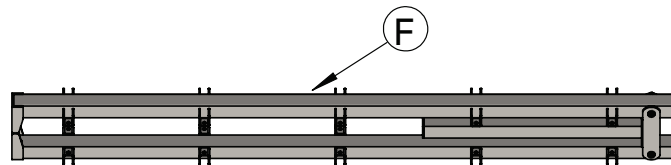
**STEP 4**

Unfold part (F) as shown.
Despliegue la pieza (F) como se muestra.
Dépliez la pièce (F) comme illustré.

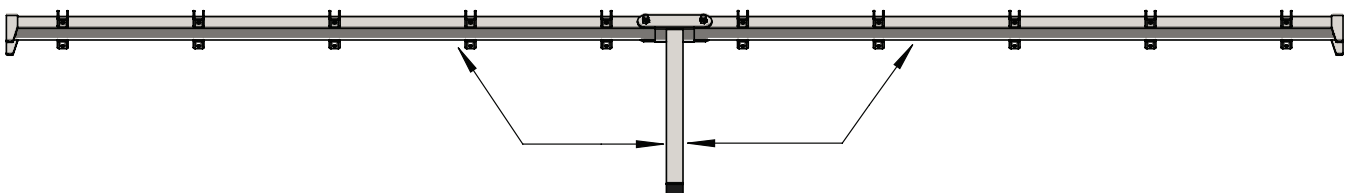

STEP 5

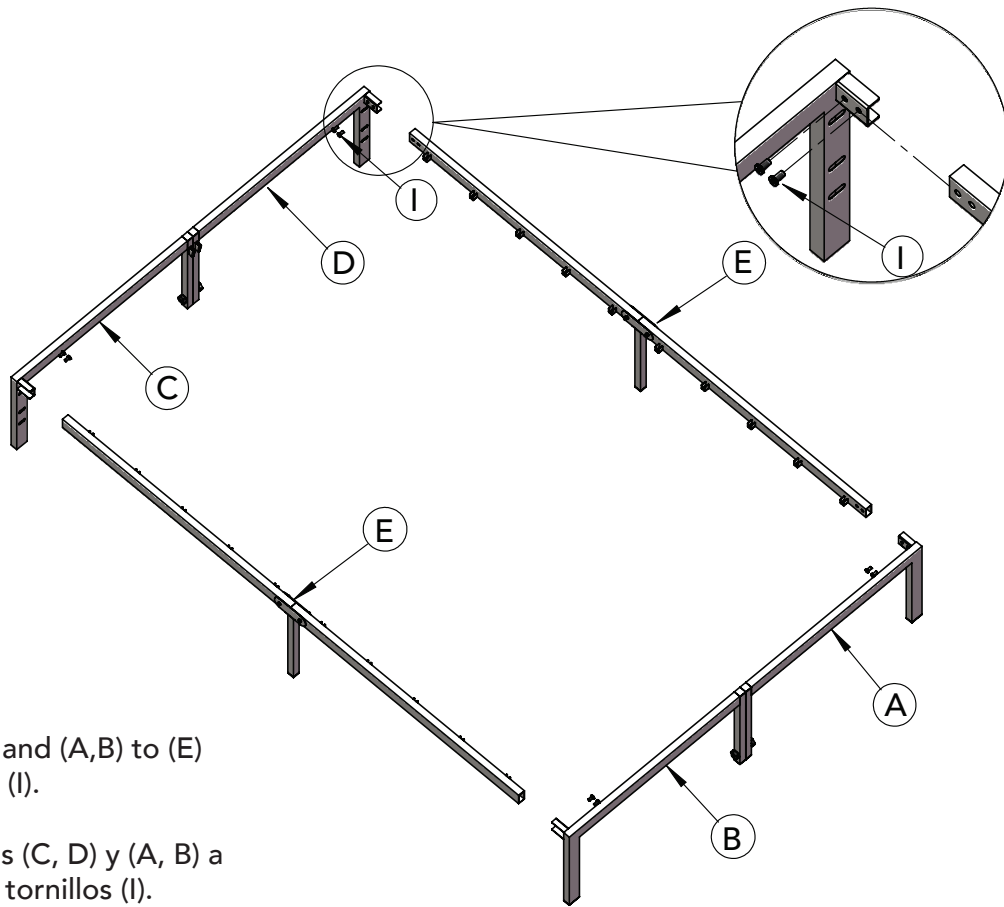

Attach (C,D) and (A,B) to (E)
using screws (I).

Fije las partes (C, D) y (A, B) a
la (E) con los tornillos (I).

Fixez (C, D) et (A, B) à (E) à
l'aide des vis (I).

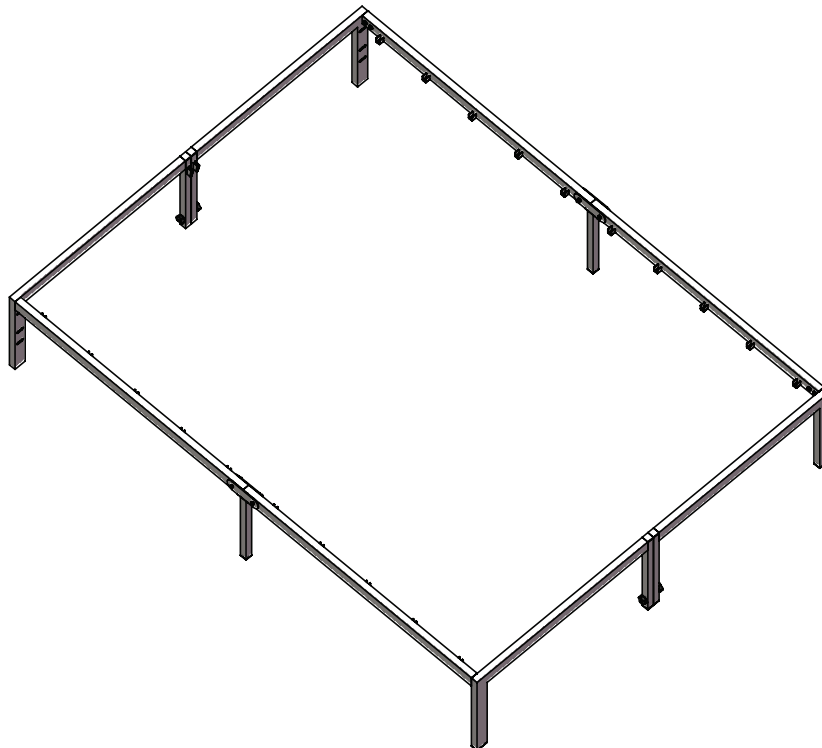

STEP 6

Attach center rail assembly (F) to the bed frame.
 Fije el ensamblaje del riel central (F) del paso (4) al marco de la cama.
 Fixez l'assemblage du rail central (F) de l'étape (4) au cadre de lit.

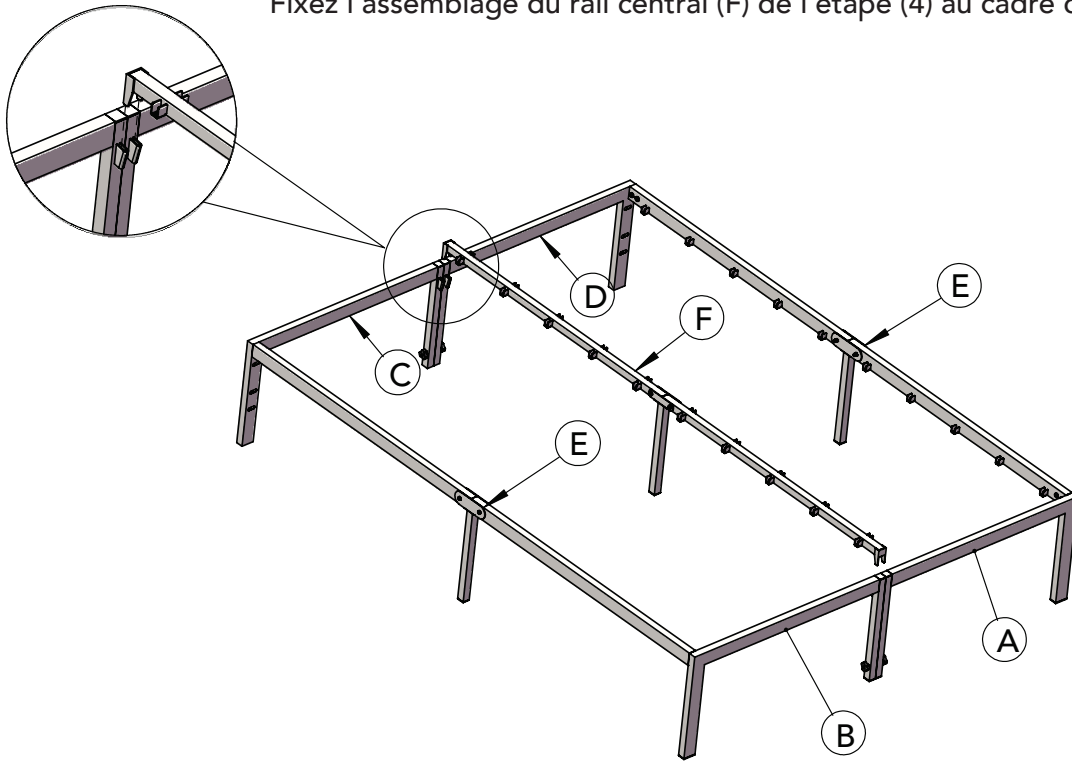

Attach parts (H) to the center rail and sideboards.
 Make sure to attach them to the slots closest to the center leg as shown.

Fije las partes (H) al riel central y a los aparadores.
 Asegúrese de unirlos a las ranuras más cercanas a la pata central como se muestra.

Fixez les pièces (H) au rail central et sur les côtés.
 Assurez-vous de les fixer aux fentes les plus proches
 du pied central com me illustré.

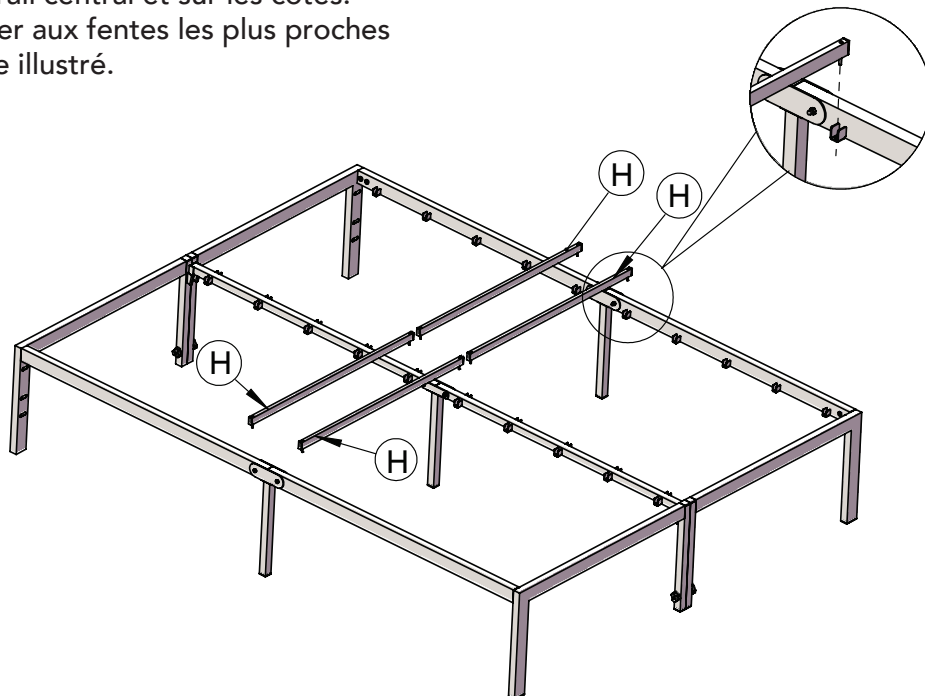

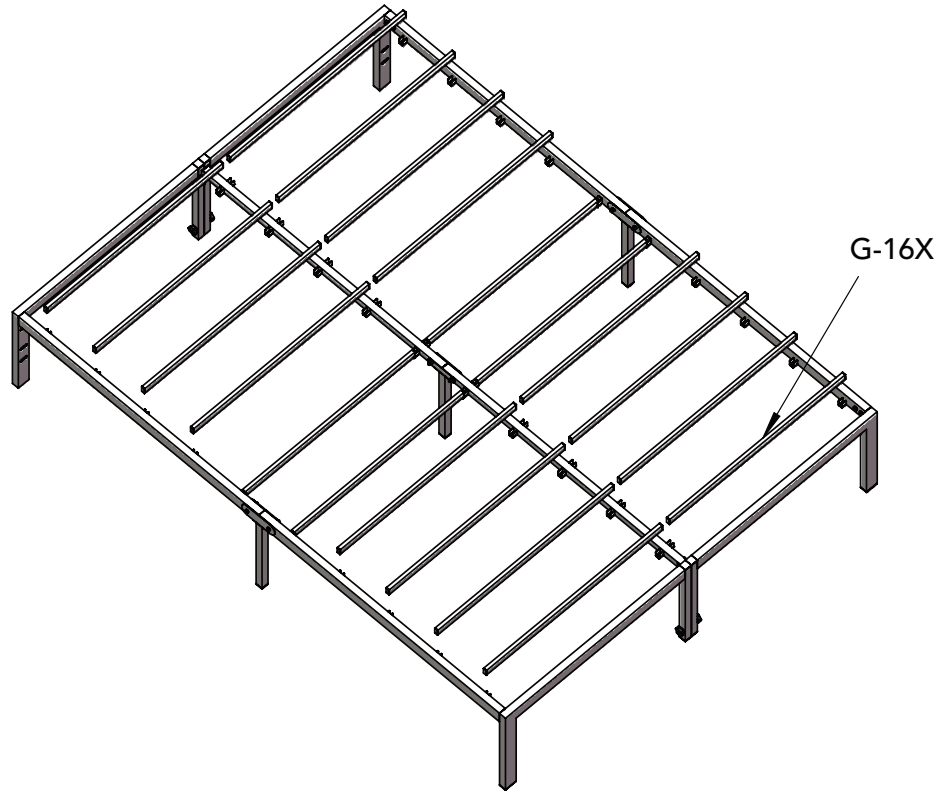
STEP 7

Attach slats to the top of the frame.
Coloque listones en la parte superior del marco.
Fixez les lattes au-dessus du cadre.

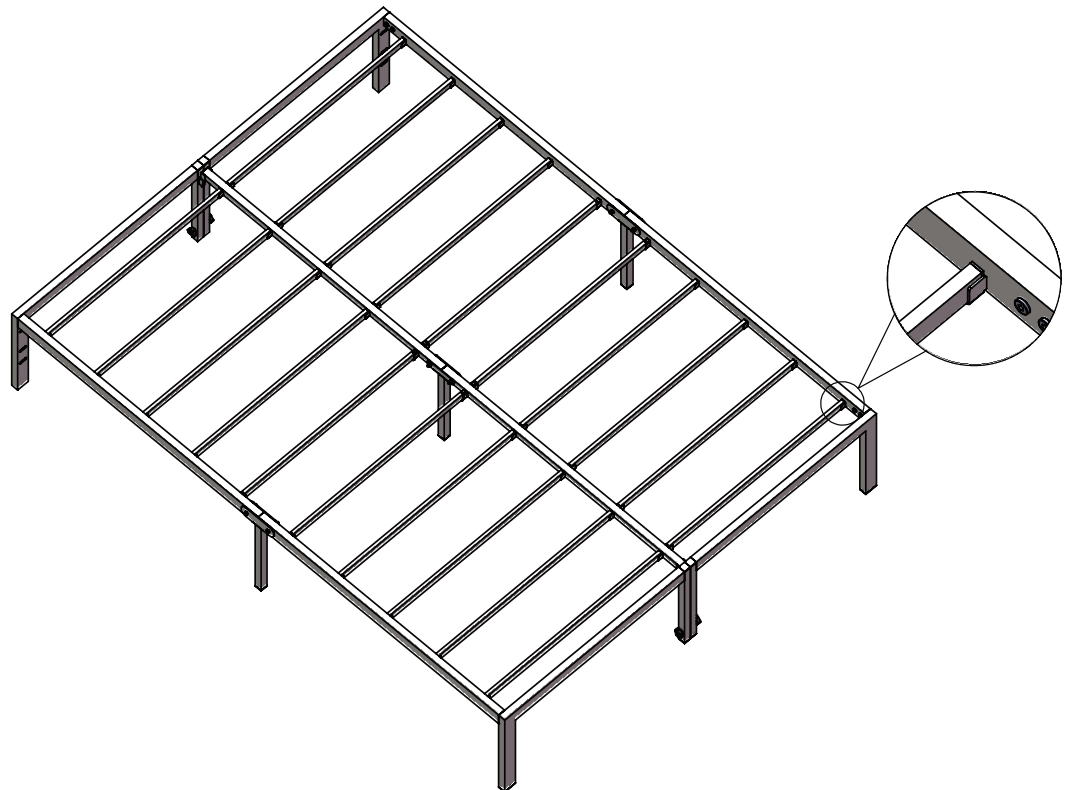

5 YEAR LIMITED WARRANTY

We are warranted for a one (5) year period from the date of purchase against defects in materials and/or workmanship.

Unless there is a clear warranty issue, the furniture are not returnable to us During this warranty period, if the product is deemed to be defective, our responsibility for the defective product is limited to replacement as stated below. All transportation costs are the responsibility of the purchaser during the entire warranty period. This Limited Warranty does not apply to and is otherwise invalid as to the following, without limitation: (1) Normal wear and tear; (2) Normal soiling from everyday use; (3) Product used for commercial, institutional, or rental purposes; (4) Damage caused by structural problems or appliance malfunctions; (5) Damage caused by or related to fire, natural disaster, flood, theft, vandalism or other crimes, or any other loss that is covered under an insurance policy; (6) Damage caused by extraordinary use; (7) Damage occurred during moves between residences or while in storage; or (8) smoke, fire, floods, or other acts of God.

WE SHALL NOT BE LIABLE FOR INCIDENTAL OR CONSEQUENTIAL DAMAGES RESULTING FROM THE USE OF THIS PRODUCT OR ARISING OUT OF ANY BREACH OF THIS WARRANTY AND THE EXCLUSIVE REMEDY FOR BREACH OF THIS WARRANTY SHALL BE REPLACEMENT OF THE PRODUCT . THE EXPRESS LIMITED WARRANTY SET FORTH HEREIN IS THE SOLE WARRANTY GIVEN BY US SHALL ONLY EXTEND TO THE ORIGINAL PURCHASER AND SHALL NOT EXTEND TO ANY SUBSEQUENT OWNER OR OTHER TRANSFEREE OF THE PRODUCT. THE REMEDIES DESCRIBED ABOVE ARE YOUR SOLE AND EXCLUSIVE REMEDIES AND OUR ENTIRE LIABILITY FOR ANY BREACH OF THIS LIMITED WARRANTY. OUR LIABILITY SHALL UNDER NO CIRCUMSTANCES EXCEED THE ACTUAL AMOUNT PAID BY YOU FOR THE DEFECTIVE PRODUCT. FOR SALES TO ANY PURCHASER, OTHER THAN THE ORIGINAL PURCHASER (AS DEFINED HEREIN), ALL IMPLIED WARRANTIES INCLUDING, BUT NOT LIMITED TO, ANY IMPLIED WARRANTY OF MERCHANTABILITY OR FITNESS FOR A PARTICULAR PURPOSE OR USE, ARE EXCLUDED AND DISCLAIMED.

This Limited Warranty is made exclusively by us and is not made on behalf of its distributors or any other party and no one is authorized to assume or undertake for our any other liability in connection with the sale of the product. Some jurisdictions do not allow for the disclaimers of implied warranties or the exclusion of limitation of incidental or consequential damages, so the above limitations may not apply to you. In the event that the disclaimer of implied warranties is not applicable to you, then such implied warranties shall only remain in effect during the limited warranty period. All determinations of applicability and validity of warranty claims hereunder are solely at the discretion of the us and such determination shall be final. THIS LIMITED WARRANTY IS NON-TRANSFERRABLE. The limited warranty set forth in this certificate apply only to the product accompanied by this Limited Warranty Certificate. This limited warranty gives you legal rights and you may have other rights which vary from state to state. This limited warranty shall be interpreted in accordance with the laws of the State of Maryland, without regard to provisions concerning conflict of laws. We reserves the right to revise, cancel, or amend its warranties offered to products sold in the future. The limited warranty set forth herein is valid and applicable to the product accompanied by this Warranty Certificate.

WARRANTY CLAIMS PROCEDURE: Should a warranty claim arise; the original purchaser shall contact us for a Warranty Claim Form and Instructions. The original purchaser shall complete the Warranty Claim Form, clearly detailing the defect, and email along with a copy of original sales receipt for the Product to claims or as otherwise directed on the Warranty Claim Form. Warranty Claim Forms that are incomplete or sent without a copy of original sales receipt will not be processed and will be returned. Upon receipt by us of the completed Warranty Claim Form and the original sales receipt, Our quality control department will verify the defect and/or the applicability of this Limited Warranty thereto. In the event that this Limited Warranty is applicable, a replacement product of equal or greater value will be sent to the customer. The original purchaser will be responsible for shipping, handling and processing fees. No monetary refunds and/or credits will be issued. Please retain this warranty and your original invoice for one (1) year.

Please retain this warranty and your original invoice for five (5) years.