

# ASSEMBLY INSTRUCTIONS

---

## Single Pedestal Desk

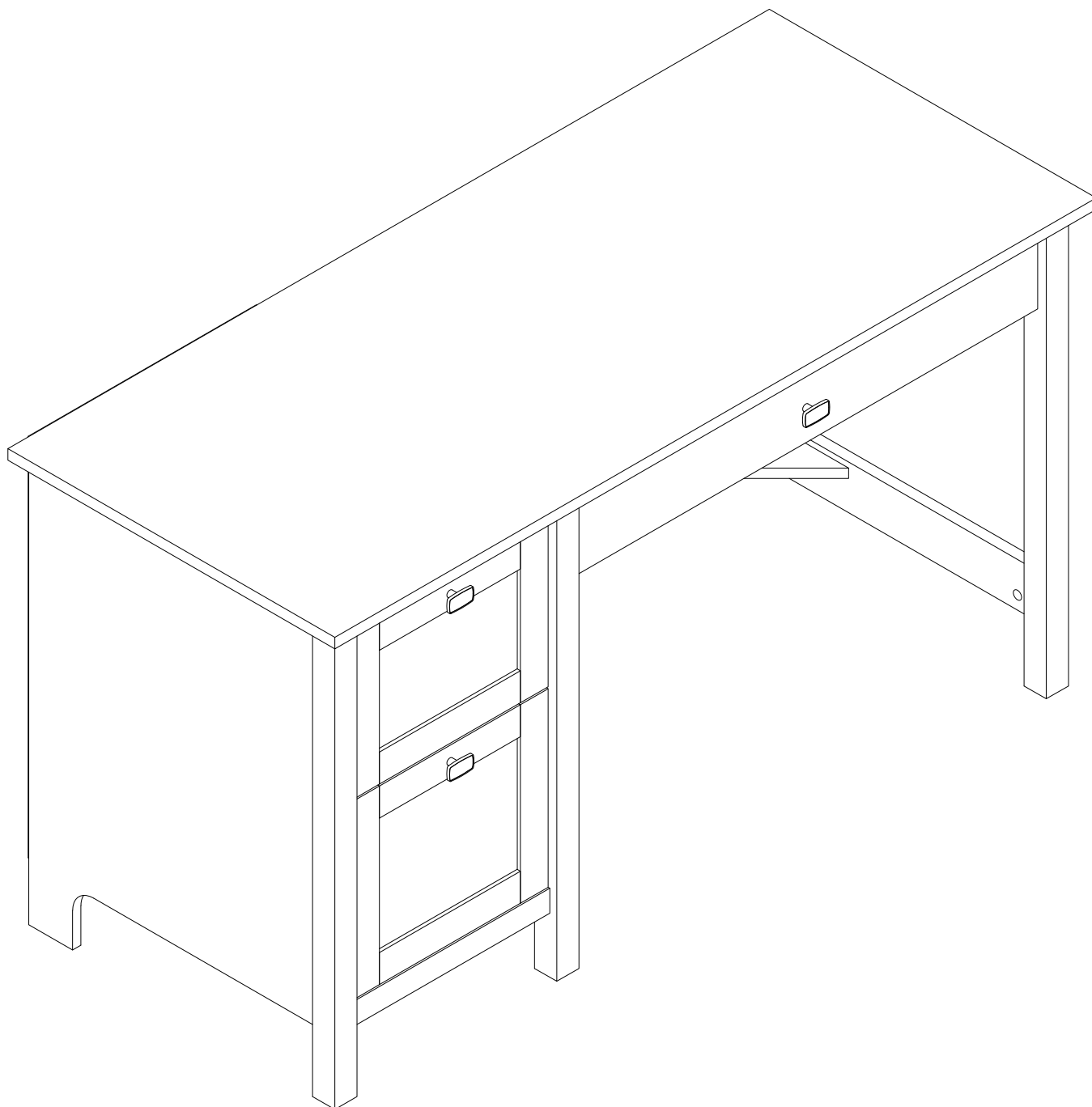

# IT'S AS EASY AS 1,2,3

**Assembly tips:**

1. Read the instructions and become familiar with the parts.
2. Ensure this carton contains all parts, fasteners and hardware.
3. To protect floors, assemble the furniture on the carton.
4. An assistant may be helpful.
5. Use of power tools is not recommended.

**Conseils d'assemblage:**

1. Lisez les instructions et familiarisez-vous avec les pièces.
2. Assurez-vous que le carton contient toutes les pièces, toutes les pièces de fixation et toute la quincaillerie.
3. Pour protéger vos sols, assemblez le meuble sur le carton.
4. Il peut être utile de vous faire aider.
5. L'utilisation d'outils électriques n'est pas recommandée.

**Consejos de Ensamblaje:**

1. Lea las instrucciones y familiarícese con las partes.
2. Asegúrese de que esta caja contenga todas las piezas, los sujetadores y el equipo.
3. Para proteger el piso, ensamble el mueble en el carton.
4. Un asistente puede serle útil.
5. El uso de herramientas eléctricas no se recomienda.

## IMPORTANT SAFETY INFORMATION



### WARNING

Units must be assembled with the instructions, parts and hardware provided. Improper assembly or use could cause structural failure, instability, tip over, and/or serious injury.

Las unidades deben ser ensambladas de acuerdo a las instrucciones y usando el herraje incluido. El ensamblado incorrecto puede causar un fallo estructural, inestabilidad, o que la unidad se derrumbe, causando posibles heridas personales.

Les unités doivent être assemblées avec les instructions et les matériels donnés. Si vous ne le construisez pas correctement ceci pourrait causer des dommages structuraux, instabilité, se renverser et blesser quelqu'un.



### WARNING

This product is designed and intended for use with computer, fax, and printer equipment only. Improper loading with television or other heavy equipment could cause instability, tip over, and/or serious injury.

Este producto está diseñado solamente para el uso con computadores, faxes, e impresoras. Inapropiado uso al poner televisores u otro equipo pesado puede causar inestabilidad, rodamiento, y/o herida (golpes) serios.

Ce produit est uniquement conçu pour une utilisation avec un ordinateur, un télécopieur, ou une imprimante. Un chargement incorrect avec une télévision ou autre matériel lourd peut le rendre instable ou le renverser, et peut vous causer des endommagements sérieux.



### WARNING

Do not move unit when loaded. Doing so could cause instability, product collapse, tip over, and/or serious injury.

No mueva la unidad cuando esté cargada. Hacerlo puede causar inestabilidad, que el producto se derrumbe, que se la caiga encima y/o heridas (golpes) serias.

Ne pas déplacer l'unité lorsqu'elle est chargée. Faire ainsi peut causer l'instabilité, l'effondrement ou le renversement du meuble et/ou des endommagements sérieux.



### WARNING

Do not load unit without properly attaching back panel. Doing so could cause instability, product collapse, and/or serious injury.

No cargue esta unidad sin el panel de atrás. Hacerlo puede causar inestabilidad, que el producto se derrumbe, y/o heridas (golpes) serias.

Ne pas charger le produit sans attacher correctement le panneau arrière. Faire ainsi peut causer l'instabilité ou l'effondrement du produit et peut vous causer des endommagements sérieux.

## MAXIMUM RECOMMENDED WEIGHT LOADS

---

MAXIMUM WEIGHT: 200 LBS (90.72 KG)  
PESO MÁXIMO: 200 LIBRAS (90.72 KILOGRAMO)  
POIDS MAXIMUM: 200 LIVRES (90.72 KILOGRAMME)

MAXIMUM WEIGHT: 15 LBS (6.8 KG)  
PESO MÁXIMO: 15 LIBRAS (6.8 KILOGRAMO)  
POIDS MAXIMUM: 15 LIVRES (6.8 KILOGRAMME)

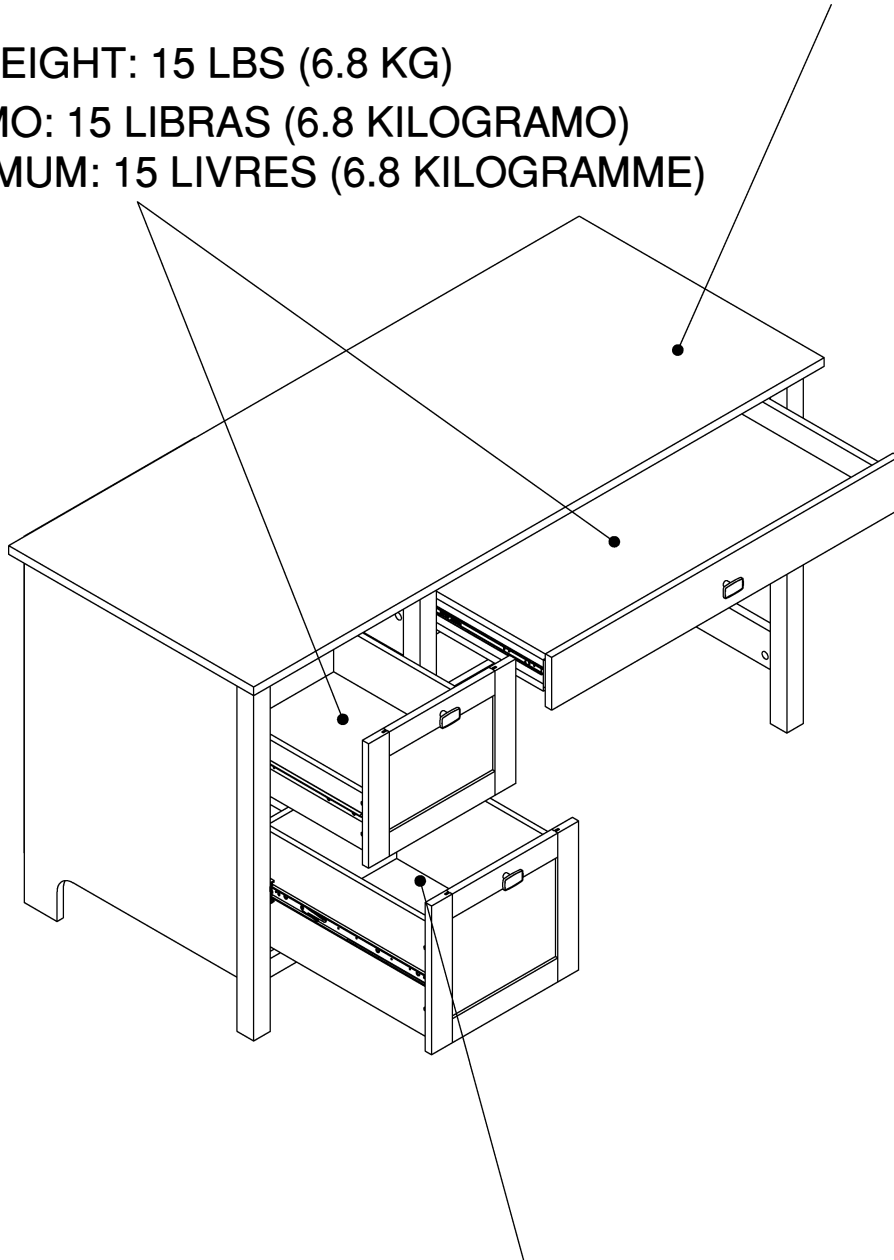





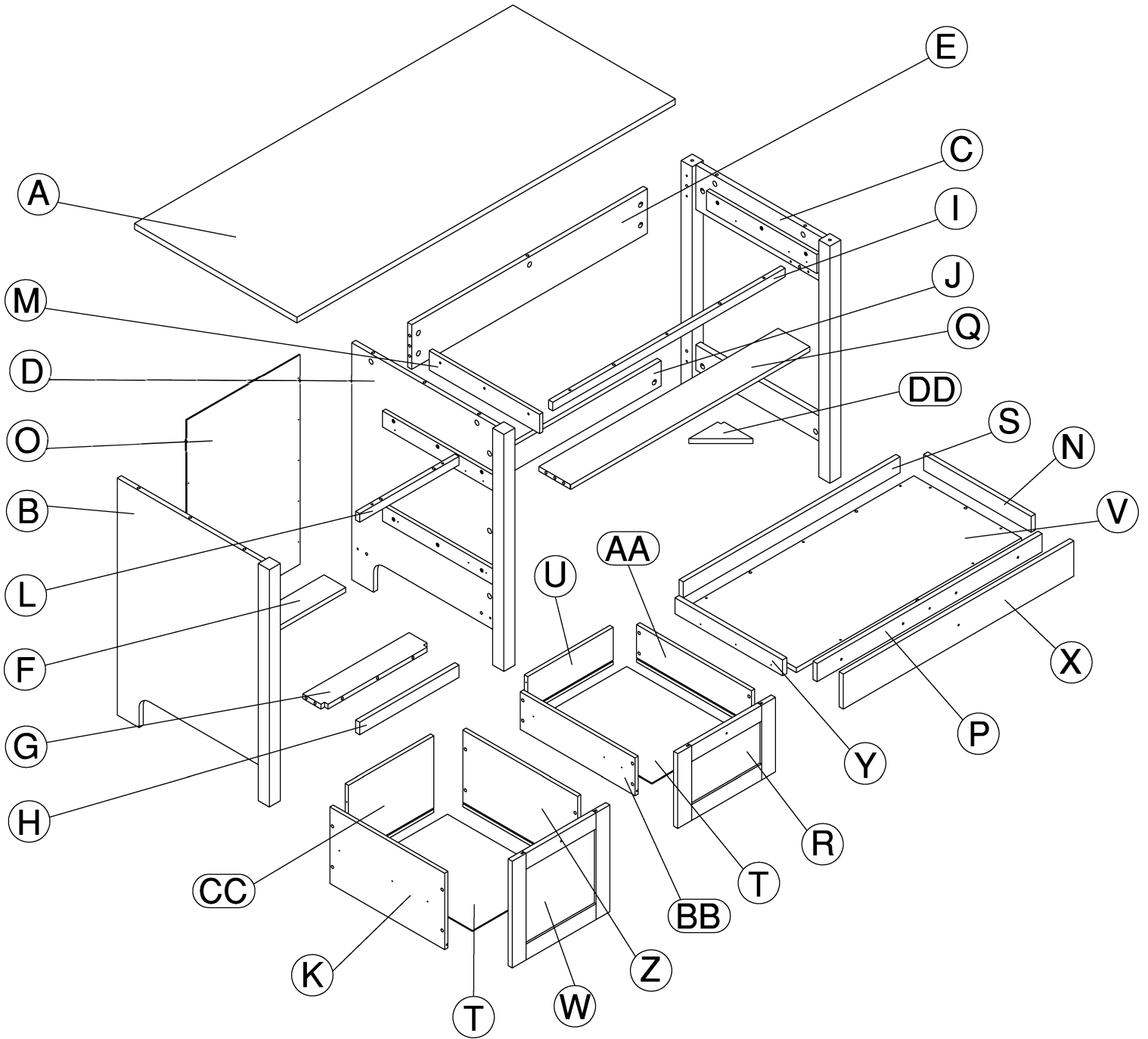
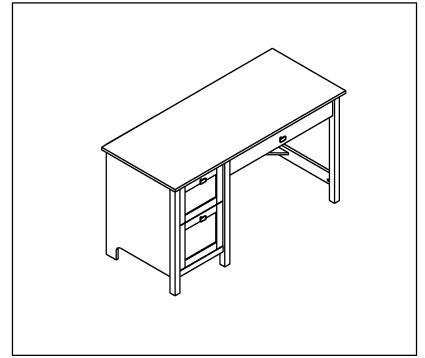

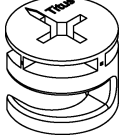
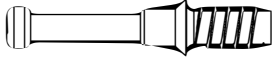
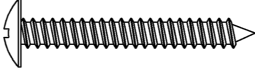

MAXIMUM WEIGHT: 30 LBS (13.61 KG)  
PESO MÁXIMO: 30 LIBRAS (13.61 KILOGRAMO)  
POIDS MAXIMUM: 30 LIVRES (13.61 KILOGRAMME)

# EXPLODED VIEW



## FASTENERS

Fasteners are shown in actual size.  
Los fijadores son demostrados en su tamaño actual.  
Les attaches sont montrées dans l'échelle grandeur.

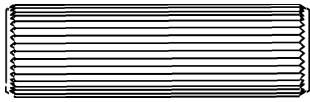
H200020	 KD Cam	[ 27 ]	H180604	 KD Bolt	[ 27 ]
H169836	 #8 x 1-1/4"	[ 5 ]	H38169	 Wood Dowel 8 x 30mm	[ 23 ]
H101725	 #6 x 1/2"	[ 8 ]	H153242	 #8 x 5/8"	[ 4 ]
H72550	 #8 x 7/8"	[ 7 ]	H23198	 #10 x 1-1/2"	[ 15 ]
H35251	 #10 x 1/2"	[ 8 ]	H146988	 #12 x 1/2"	[ 2 ]
H203743	 Wood Dowel 12 x 40mm	[ 2 ]			

# HARDWARE

H100446  [ 2 ]  
Drawer Bracket

H100445  [ 2 ]  
Drawer Bracket

H180671  [ 2 ]  
Bumper  
Ø12x6mm

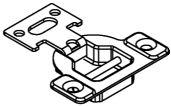
H180675  [ 2 ]  
Hinge

H158780  [ 1 ]  
File Extrusion  
12-1/8" (308mm)

H89793  [ 1 ]  
File Bar  
12-1/2" (318mm)

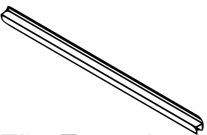
H162488  [ 2 ]  
File Extrusion  
15-3/4" (400mm)

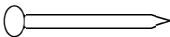
H200011  [ 16 ]  
Nail

H200135  [ 4 ]  
Cover Cap

H200135  [ 4 ]  
Cover Cap

H202770  [ 4 ]  
Cover Cap

# HARDWARE

---

H175335

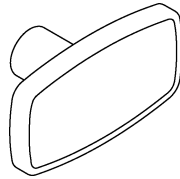

[ 3 ]

Handle

H160460



[ 3 ]

M4 x 22mm

---

H174929

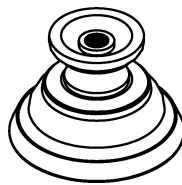

[ 3 ]

Pull

H174930



[ 3 ]

Knob Cap

H157181



[ 3 ]

#8-32 x 1-1/8"

**PRE-ASSEMBLED COMPONENTS**

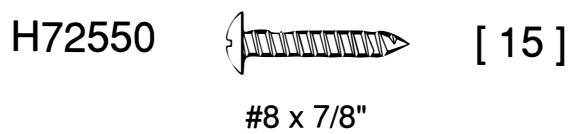
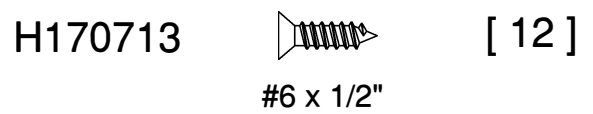
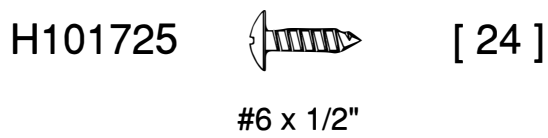
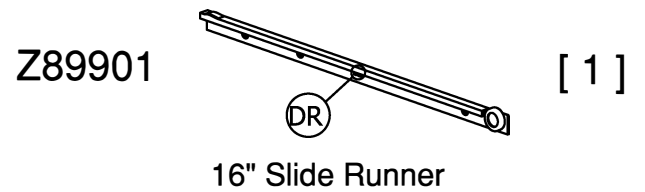
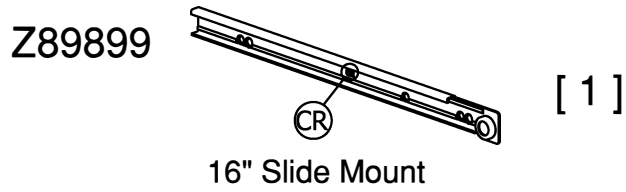
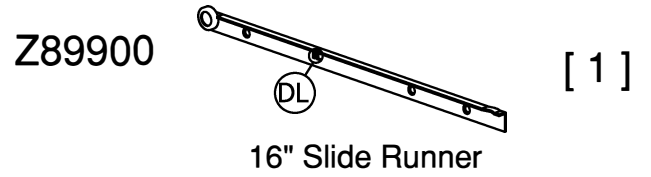
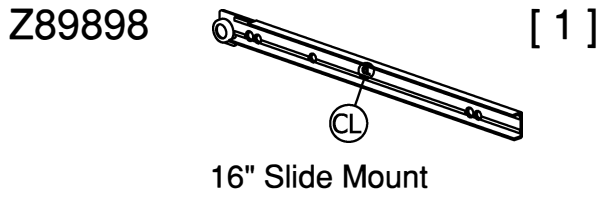
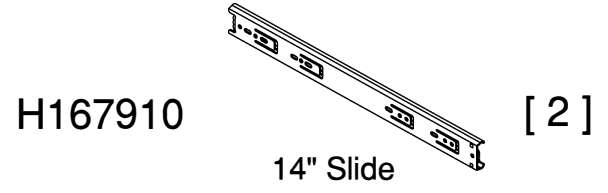
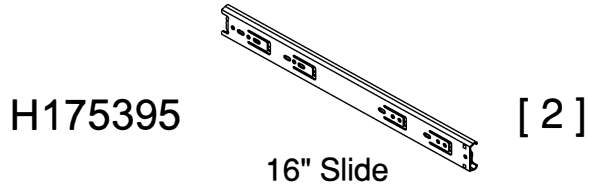

# STEP 1

H38169



[ 5 ]

Wood Dowel 8 x 30mm

H180604

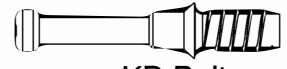

KD Bolt

[ 2 ]

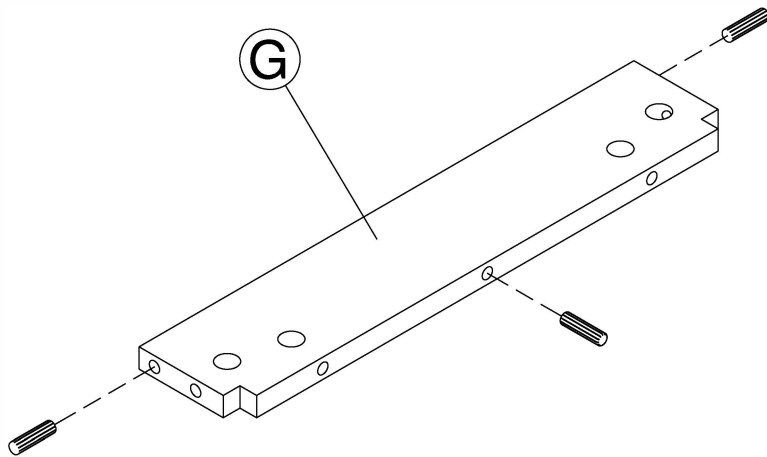
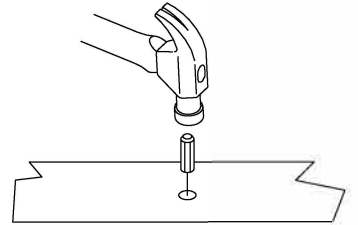
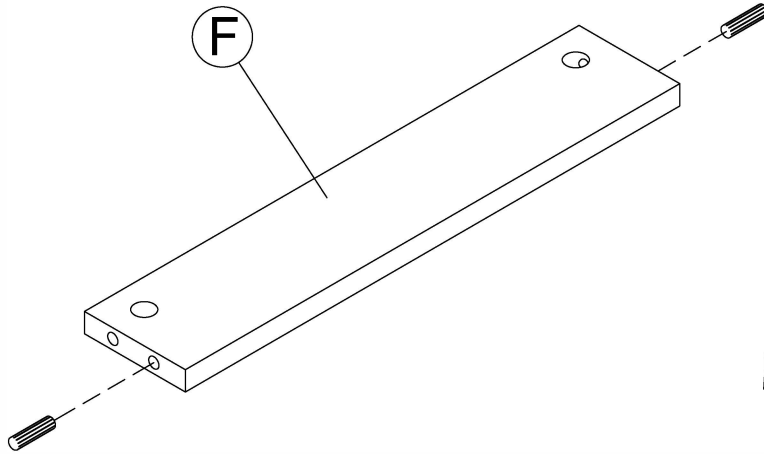

Safety glasses  
Gafas de seguridad  
Lunettes de protection

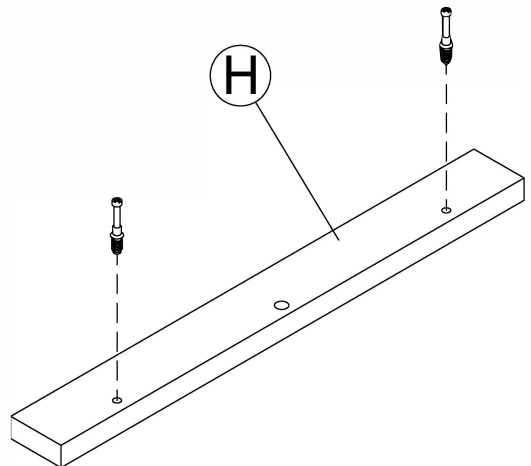
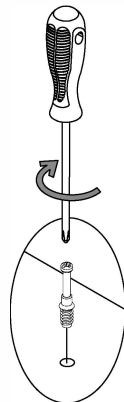

# STEP 2

H200020

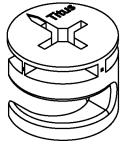

KD Cam

[ 2 ]

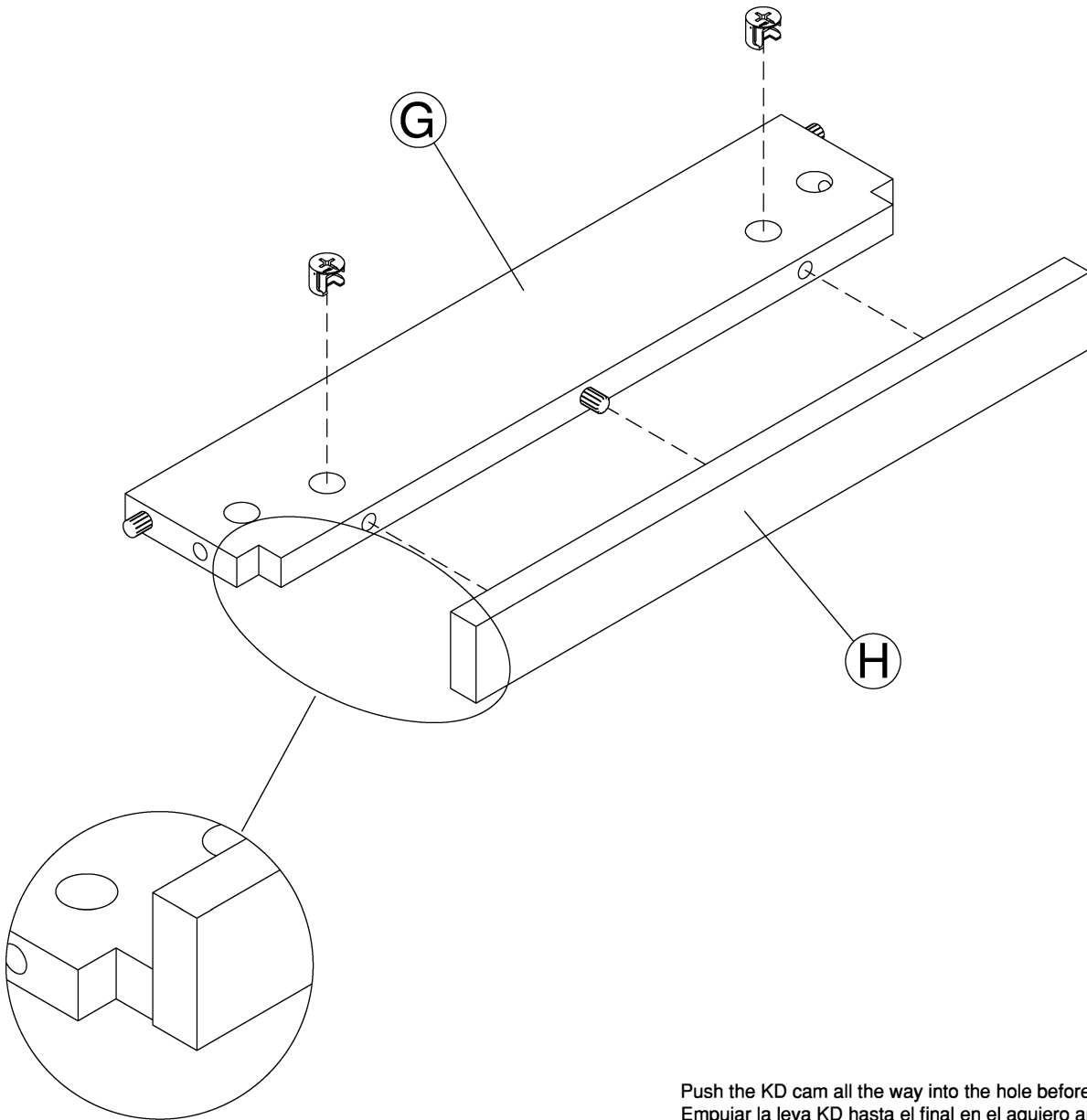

Push the KD cam all the way into the hole before tightening.  
Empujar la leva KD hasta el final en el agujero antes de apretar.  
Pousser la came de KD tout le chemin dans le trou avant de serrer.

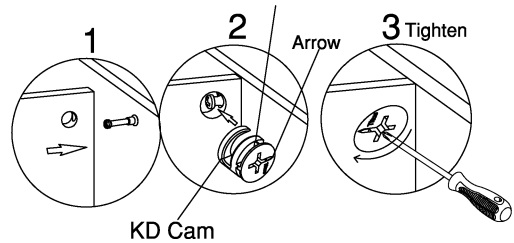

### STEP 3

H38169

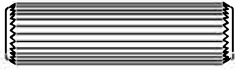

[ 1 ]

Wood Dowel 8 x 30mm

H180604

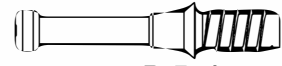

[ 2 ]

KD Bolt

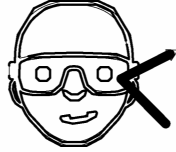
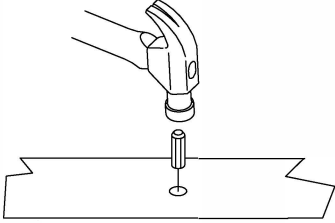

Safety glasses  
Gafas de seguridad  
Lunettes de protection

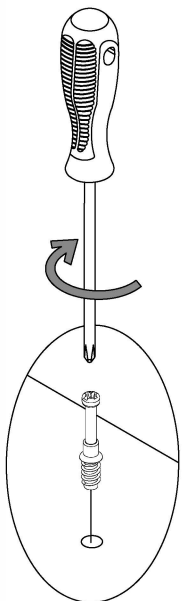
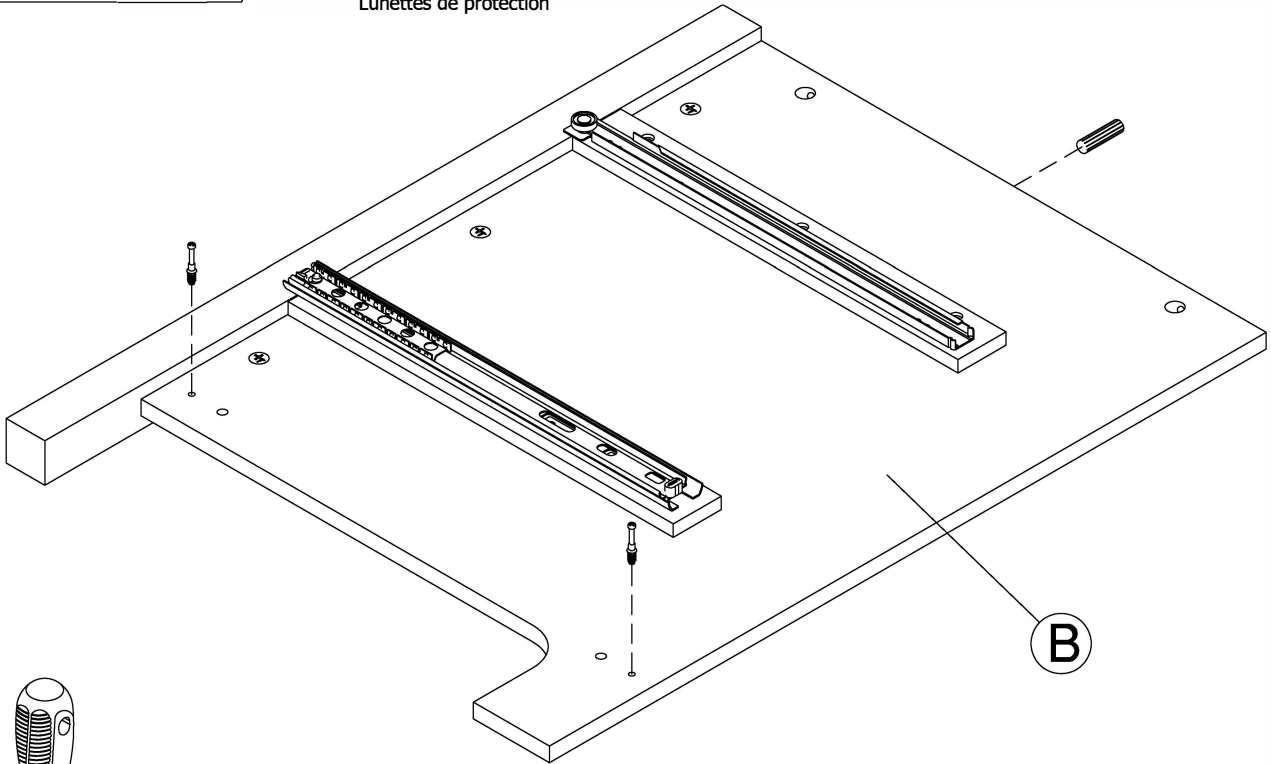



# STEP 5

H200020

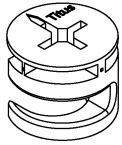

KD Cam

[ 2 ]

Push the KD cam all the way into the hole before tightening.  
Empujar la leva KD hasta el final en el agujero antes de apretar.  
Pousser la came de KD tout le chemin dans le trou avant de serrer.

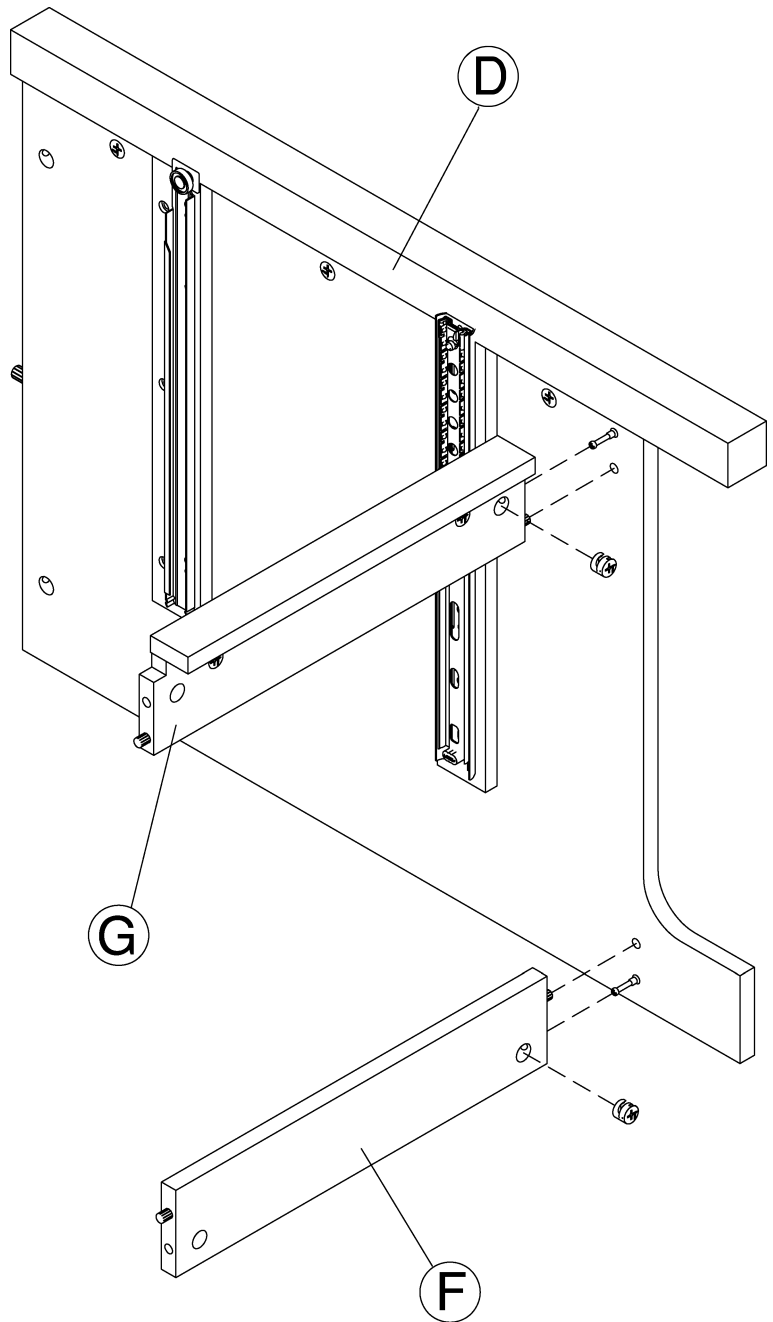
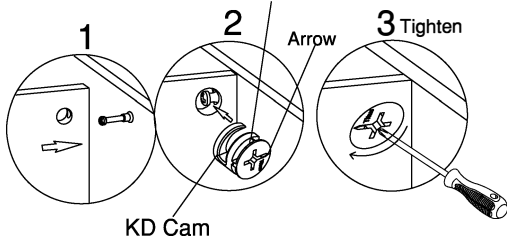

An assistant is required.  
Es necesario un ayudante.  
Un assistant est nécessaire.

# STEP 6

H200020

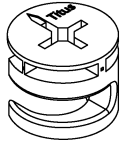

KD Cam

[ 2 ]

Push the KD cam all the way into the hole before tightening.  
Empujar la leva KD hasta el final en el agujero antes de apretar.  
Pousser la came de KD tout le chemin dans le trou avant de serrer.

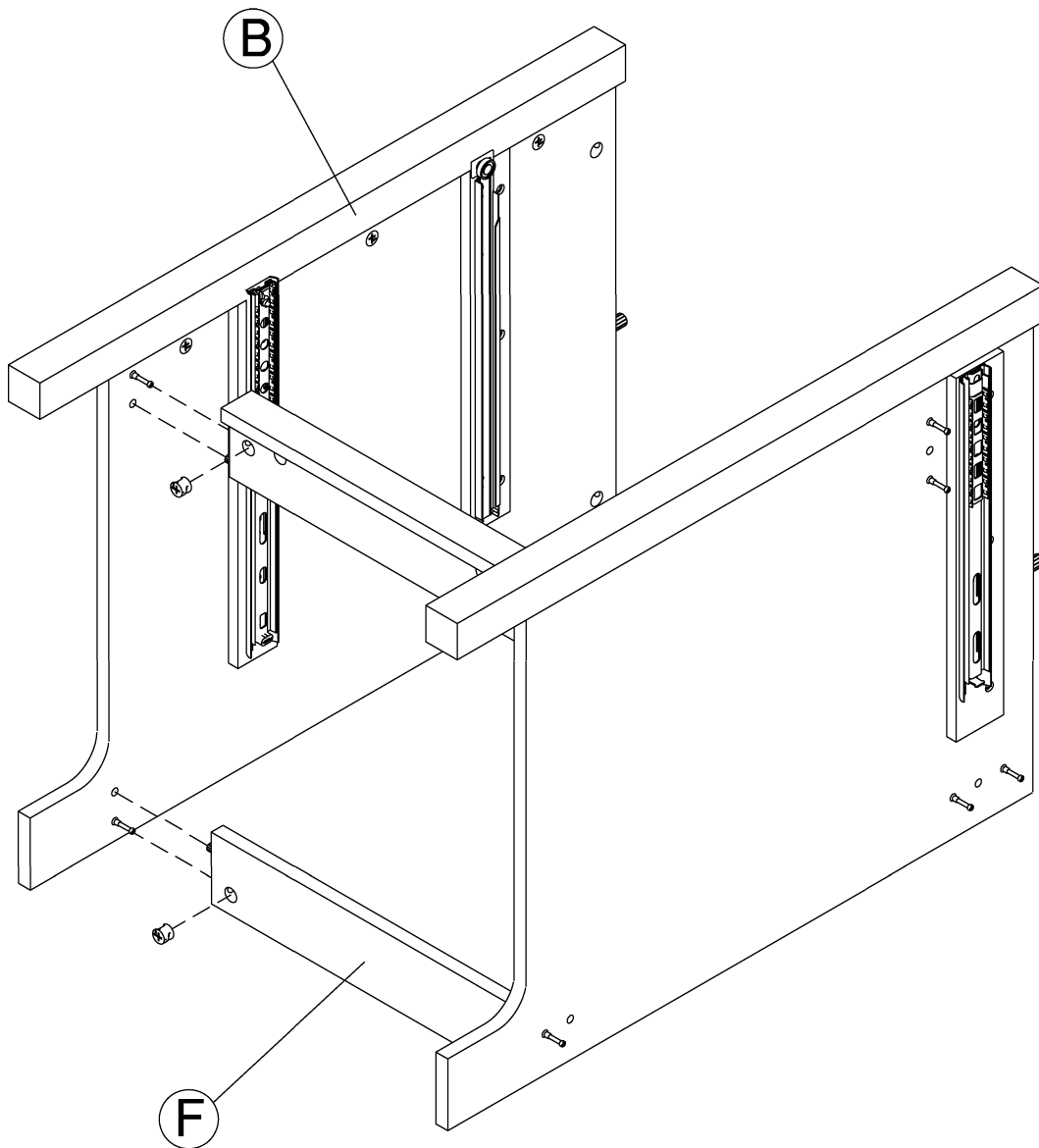
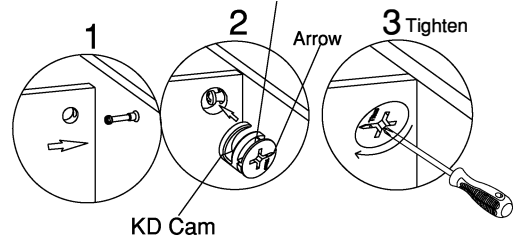

An assistant is required.  
Es necesario un ayudante.  
Un assistant est nécessaire.

# STEP 7

H38169



[ 6 ]

Wood Dowel 8 x 30mm

H180604

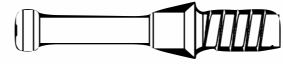

[ 2 ]

KD Bolt

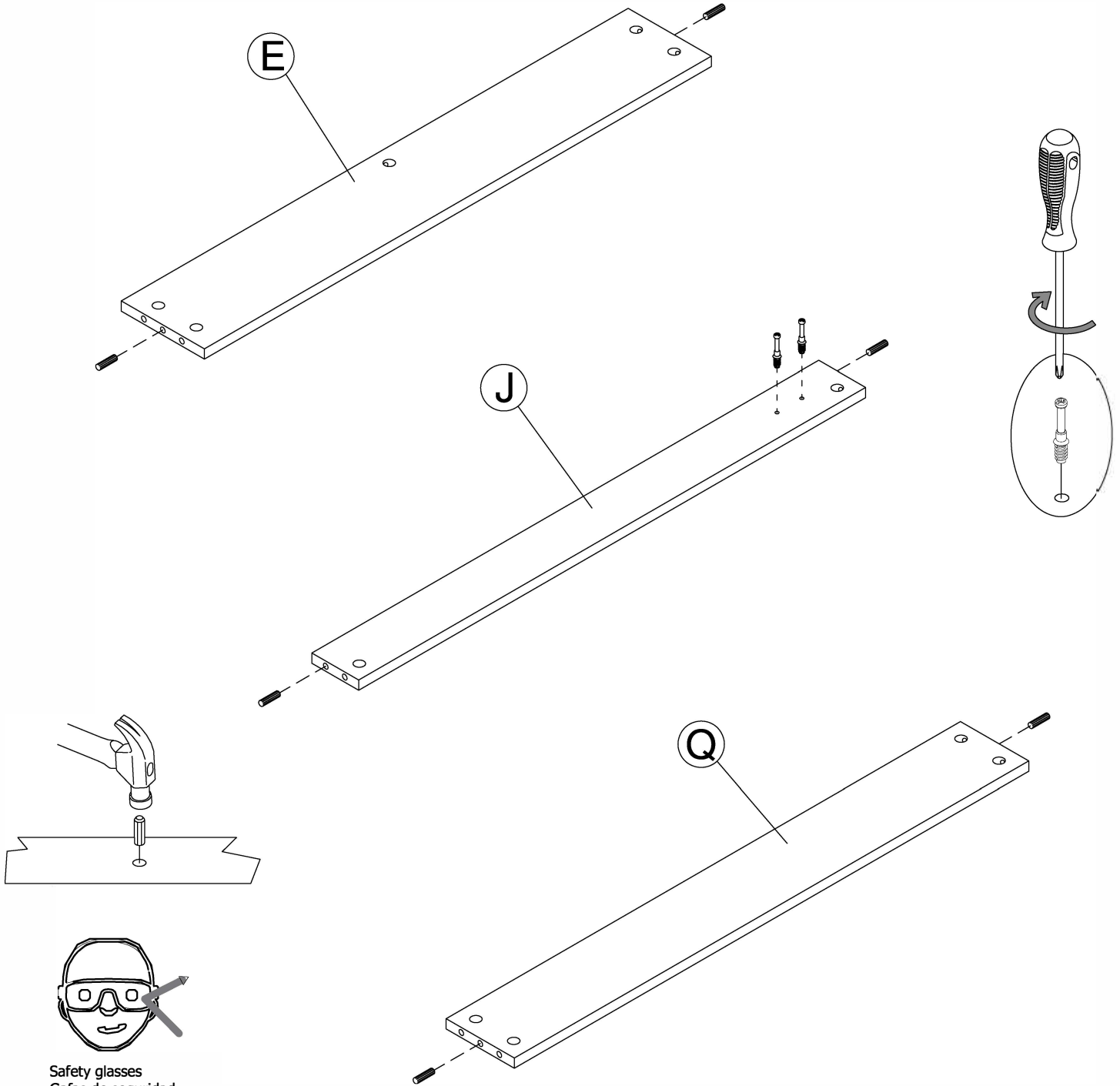

Safety glasses  
Gafas de seguridad  
Lunettes de protection

# STEP 8

H200020

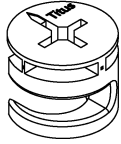

KD Cam

[ 5 ]

H200135  
H202770



Cover Cap

[ 1 ]

Push the KD cam all the way into the hole before tightening.  
Empujar la leva KD hasta el final en el agujero antes de apretar.  
Pousser la came de KD tout le chemin dans le trou avant de serrer.

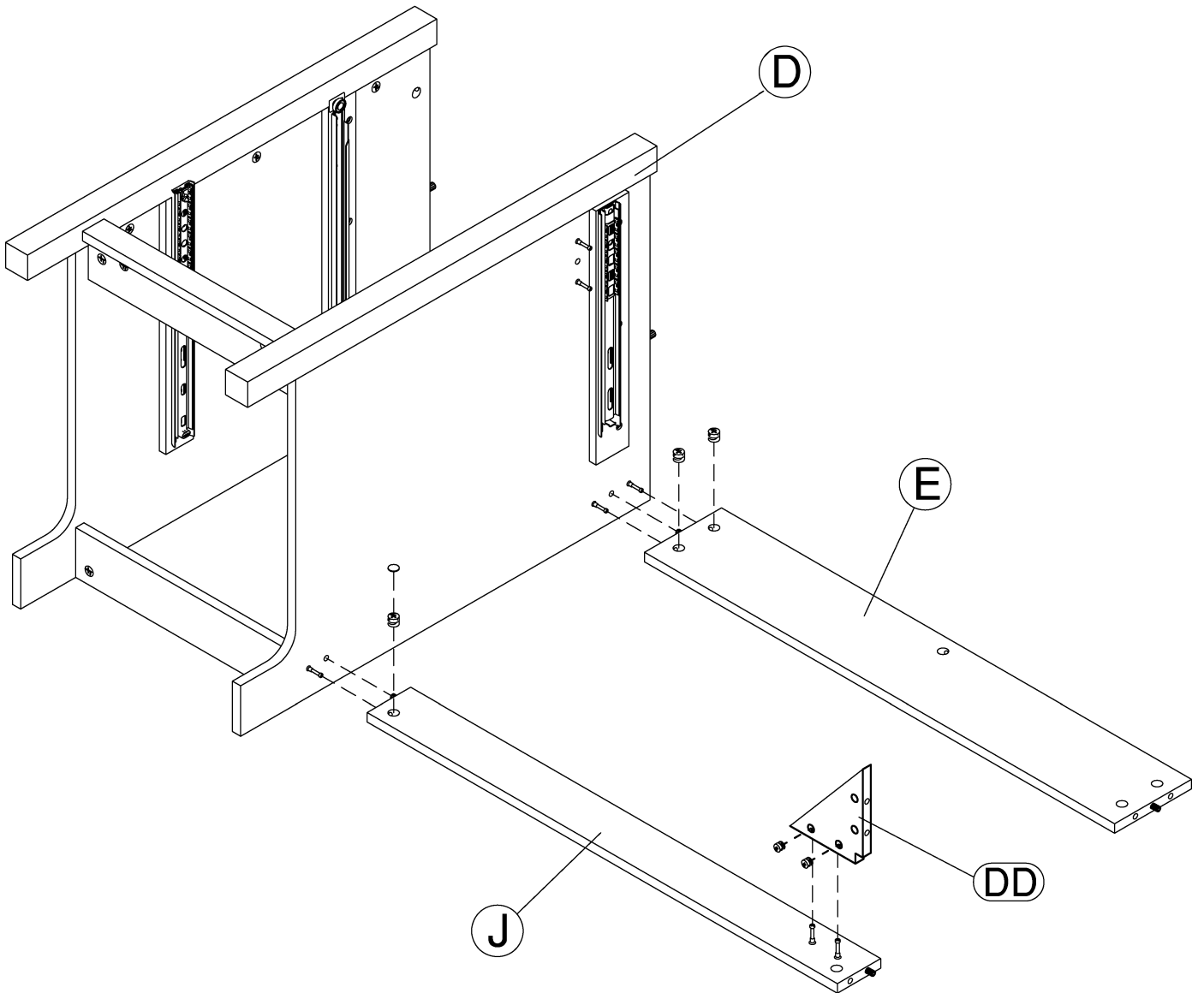
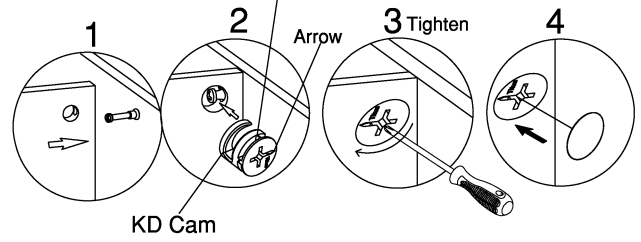

# STEP 9

H200020

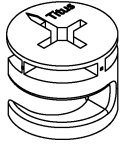

KD Cam

[ 2 ]

Push the KD cam all the way into the hole before tightening.  
Empujar la leva KD hasta el final en el agujero antes de apretar.  
Pousser la came de KD tout le chemin dans le trou avant de serrer.

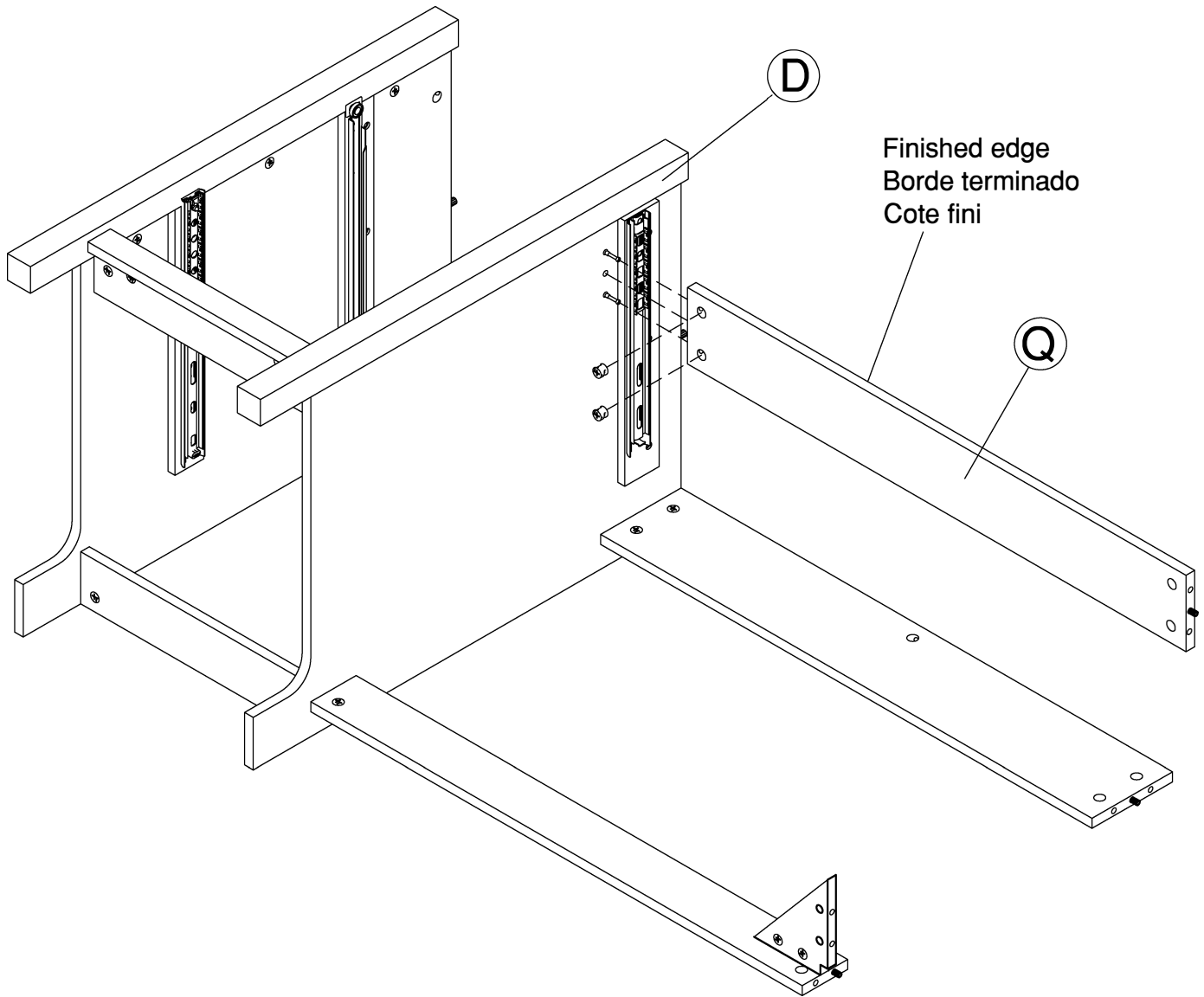
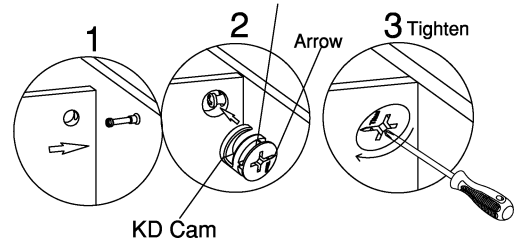

An assistant is required.  
Es necesario un ayudante.  
Un assistant est nécessaire.

**STEP 10**

H203743

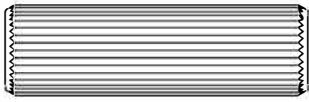

[ 2 ]

Wood Dowel 12 x 40mm

H180604

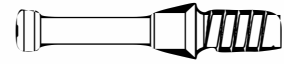

KD Bolt

[ 7 ]

H200135  
H202770



[ 2 ]

Cover Cap

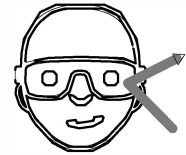
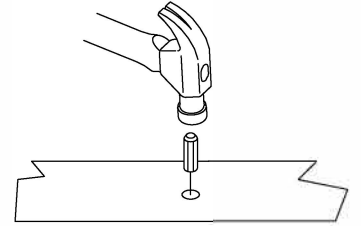
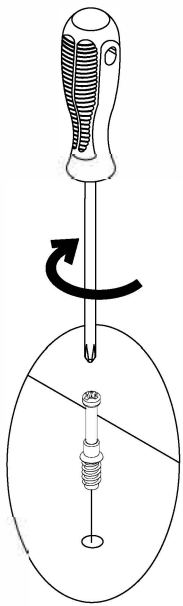

Safety glasses  
Gafas de seguridad  
Lunettes de protection

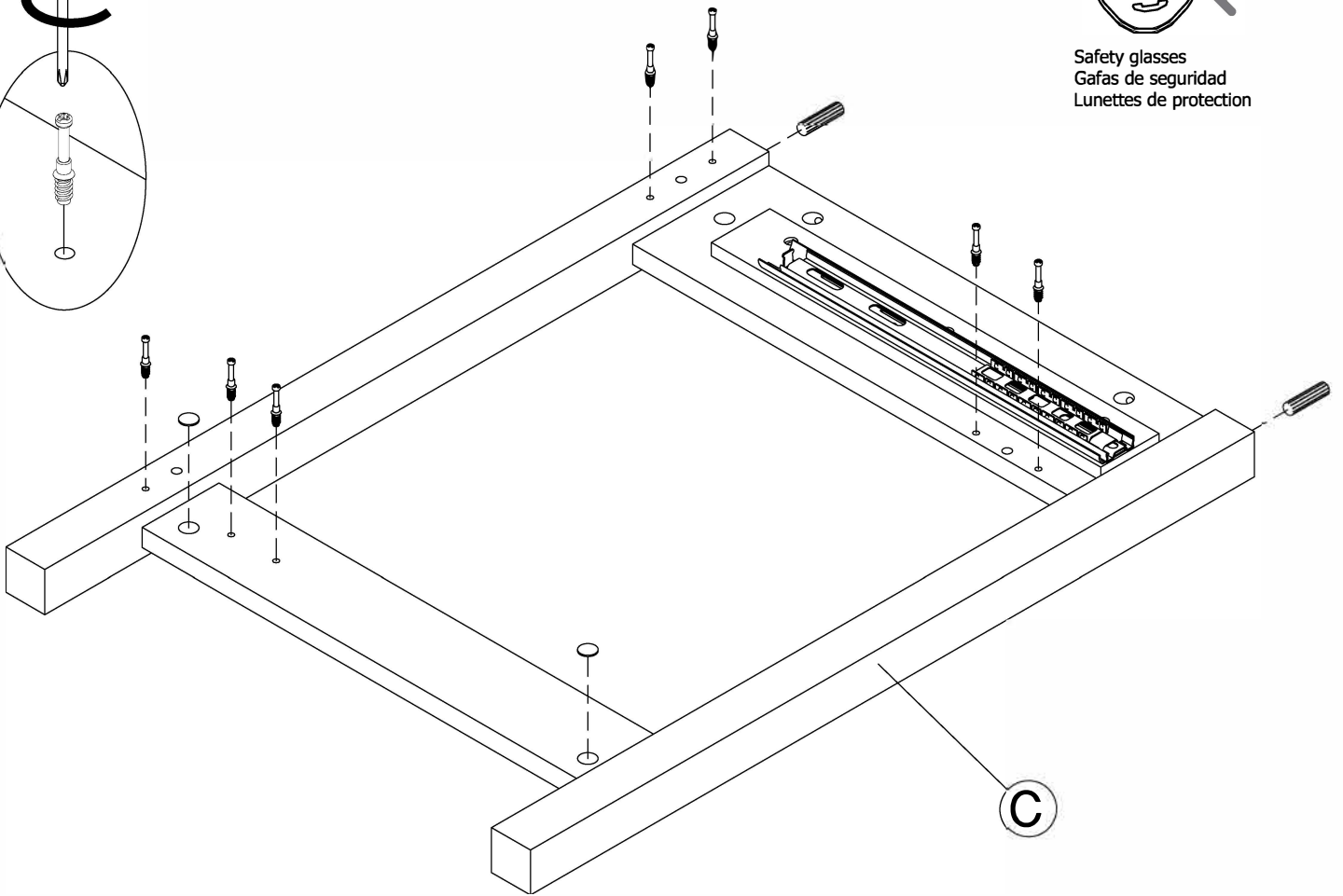

# STEP 11

H200020

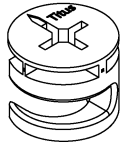

KD Cam

[ 7 ]

H200135  
H202770



Cover Cap

[ 1 ]

Push the KD cam all the way into the hole before tightening.  
Empujar la leva KD hasta el final en el agujero antes de apretar.  
Pousser la came de KD tout le chemin dans le trou avant de serrer.

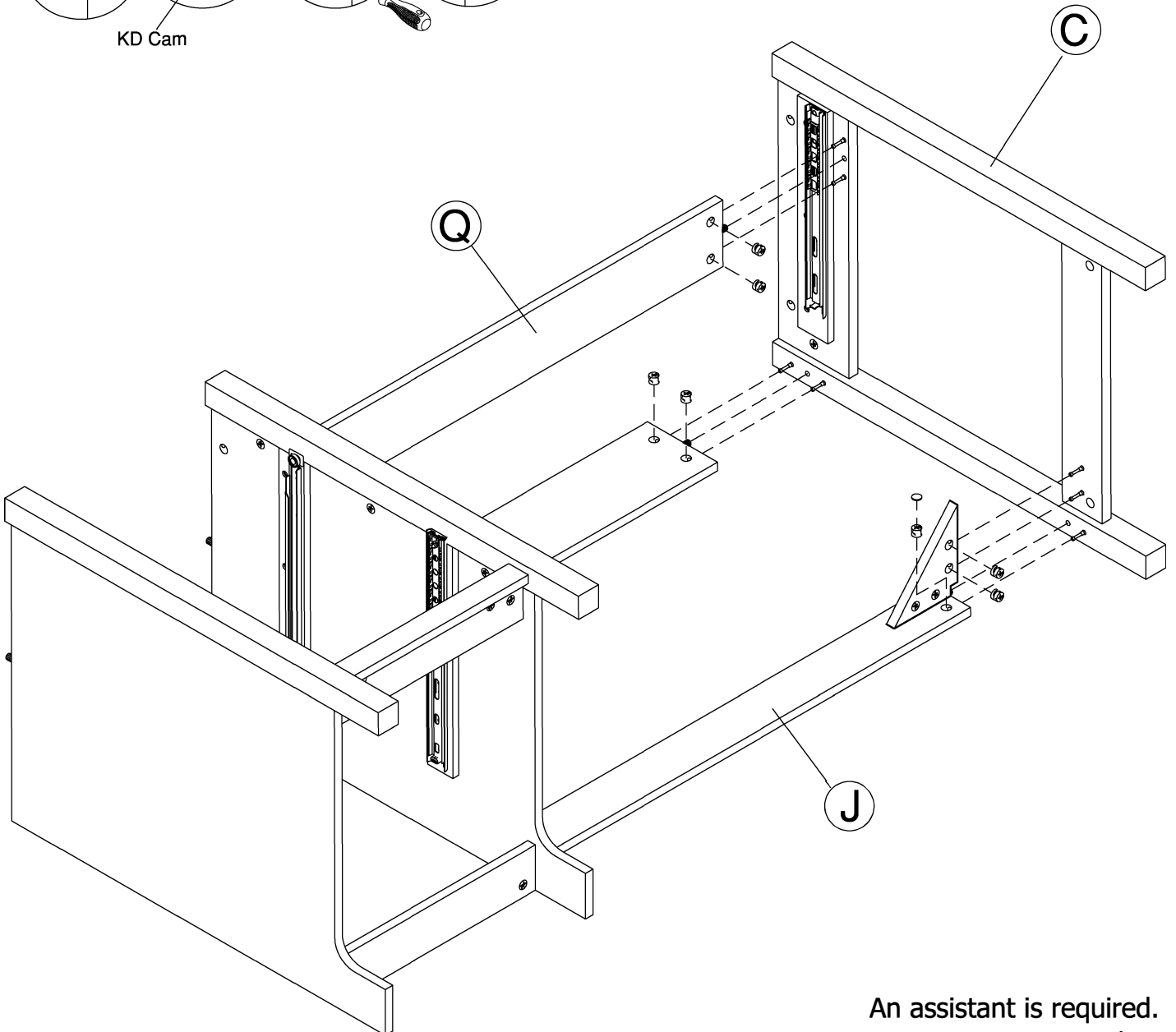
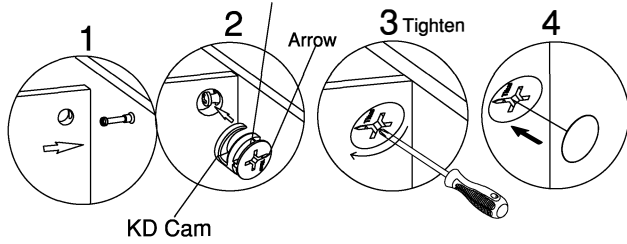

An assistant is required.  
Es necesario un ayudante.  
Un assistant est nécessaire.

## STEP 12

H38169

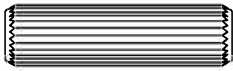

[ 4 ]

Wood Dowel 8 x 30mm

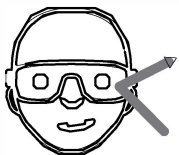
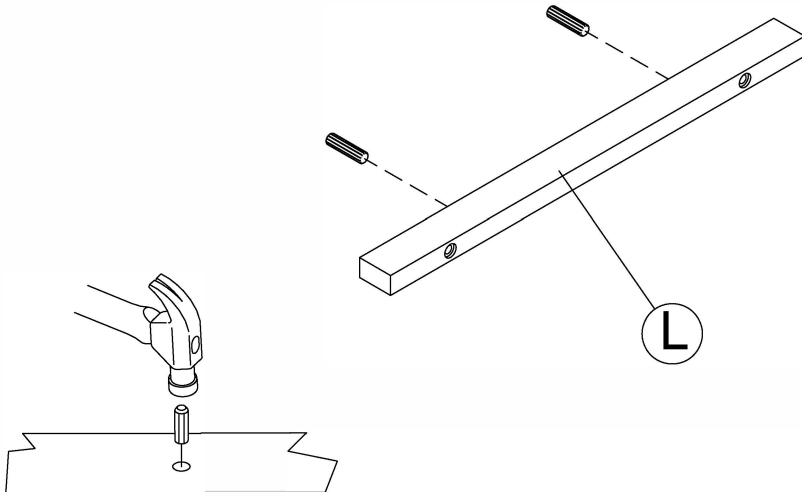

Safety glasses  
Gafas de seguridad  
Lunettes de protection

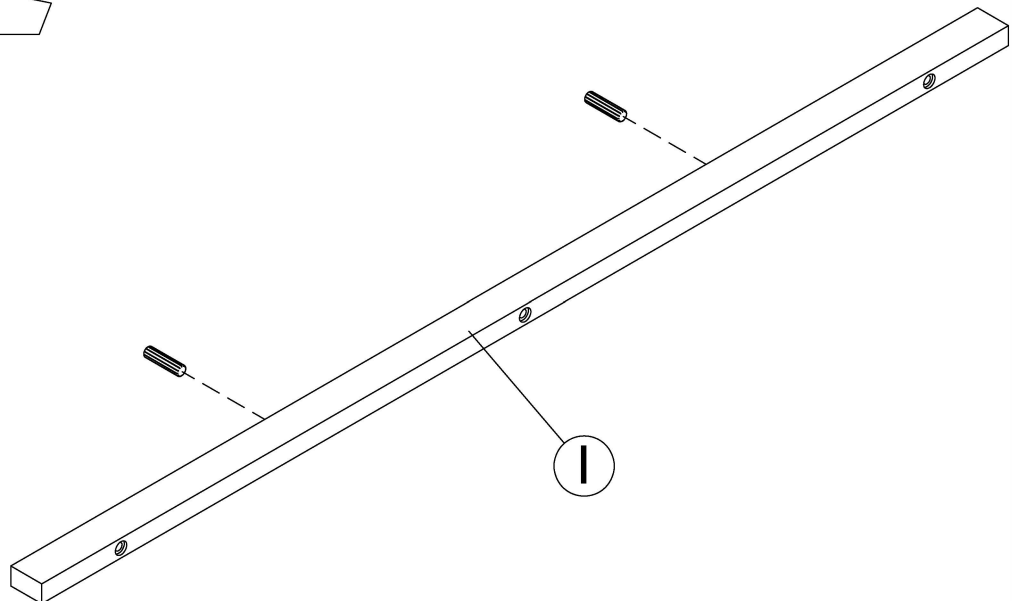

**STEP 13**

H180604



KD Bolt

[ 7 ]

H169836



[ 2 ]

#8 x 1-1/4"

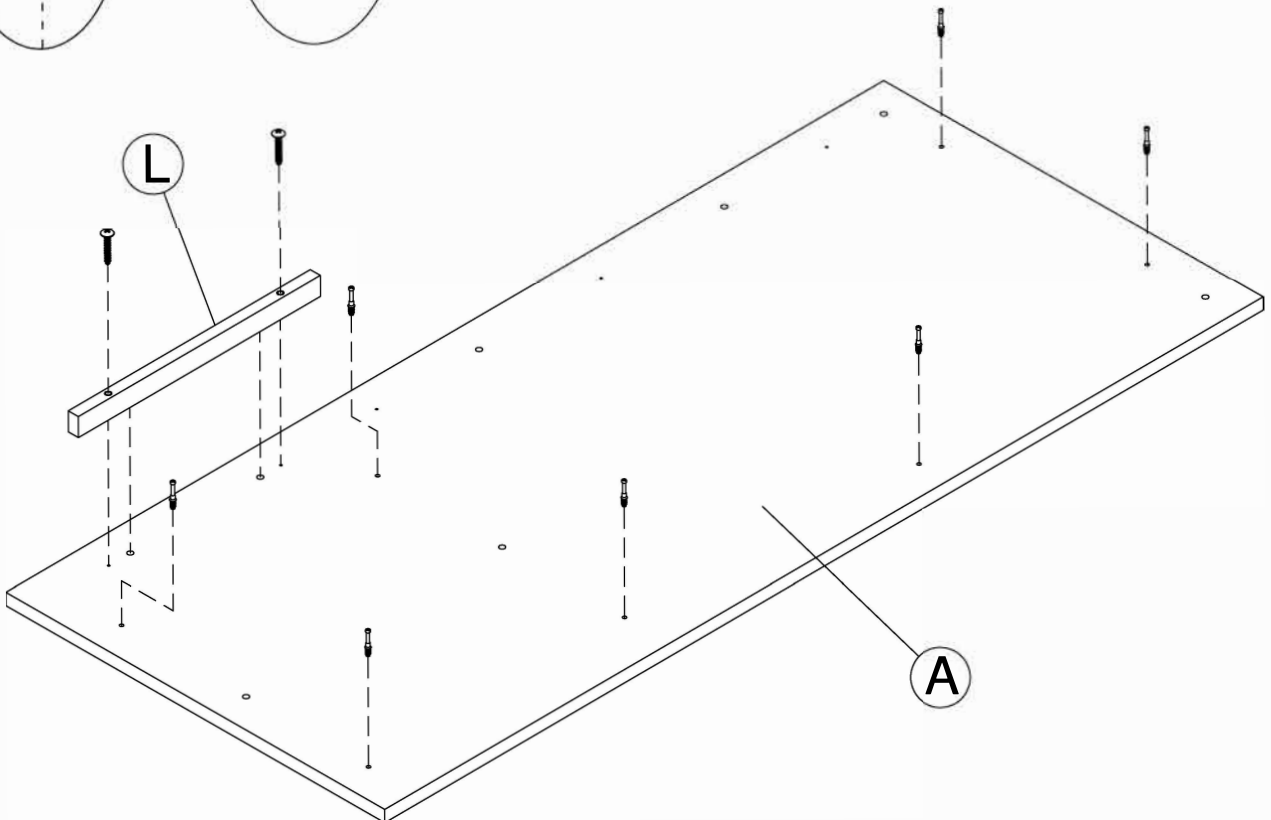
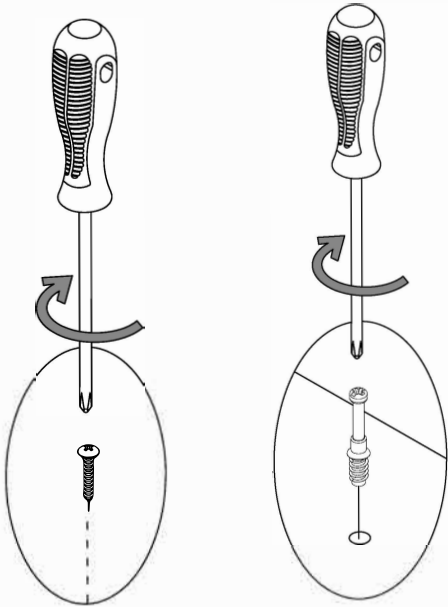

# STEP 14

H200020

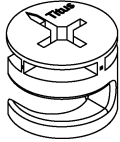

[ 7 ]

KD Cam

With assistant carefully stand unit up.

Con un asistente cuidadosamente levante la unided a una posicion vertical.

Avec l'aidé d'un assistant placez soigneusement l'unité debout.

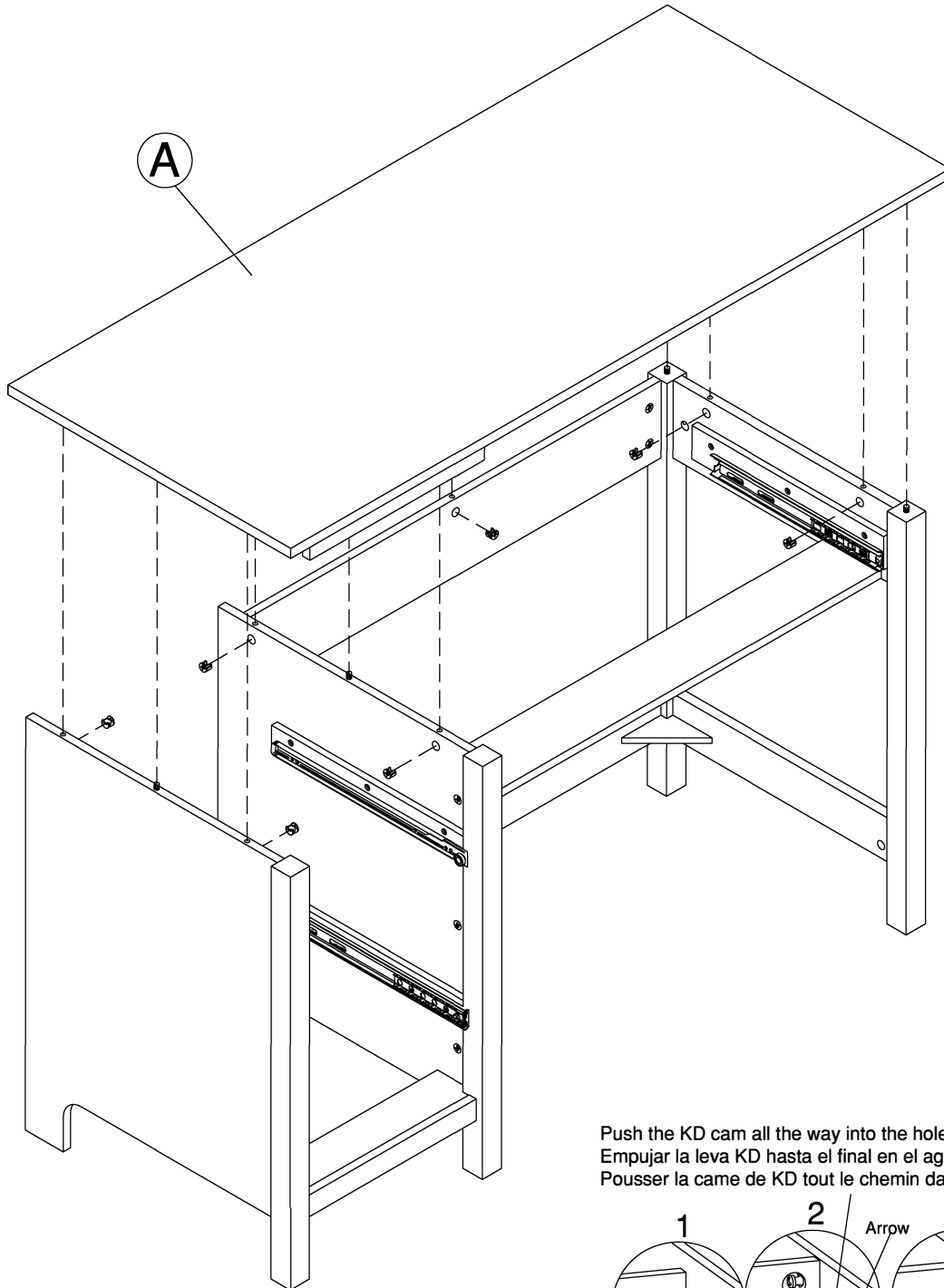

Push the KD cam all the way into the hole before tightening.  
Empujar la leva KD hasta el final en el agujero antes de apretar.  
Pousser la came de KD tout le chemin dans le trou avant de serrer.

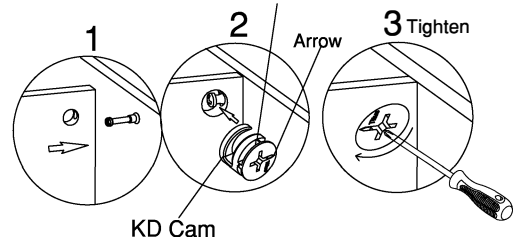

**STEP 15**

H169836

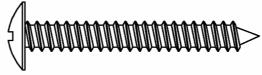

[ 3 ]

#8 x 1-1/4"

An assistant is required.  
Es necesario un ayudante.  
Un assistant est nécessaire.

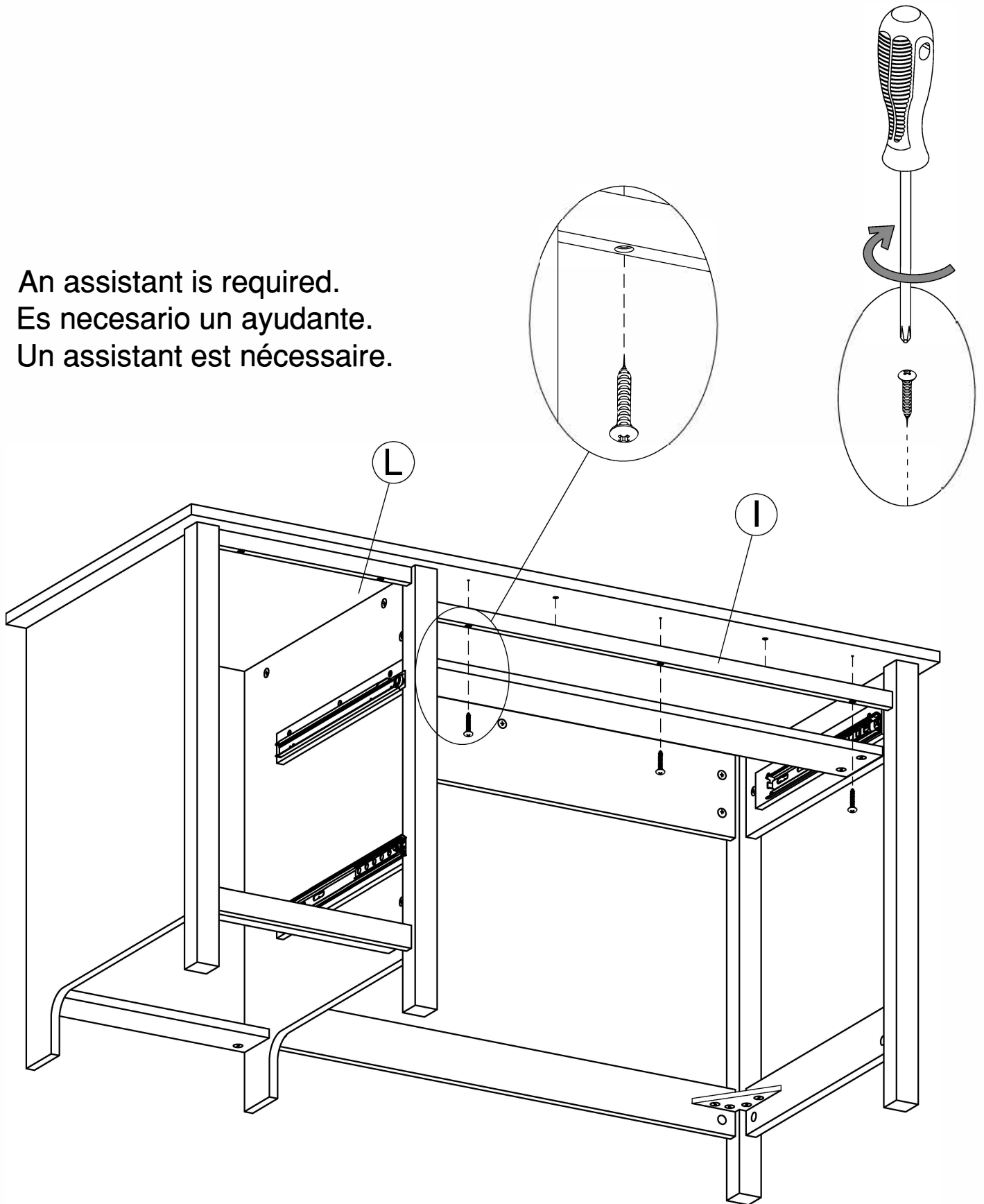

# STEP 16

H200011

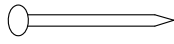

[ 16 ]

Nail

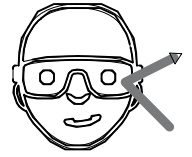

Safety glasses  
Gafas de seguridad  
Lunettes de protection

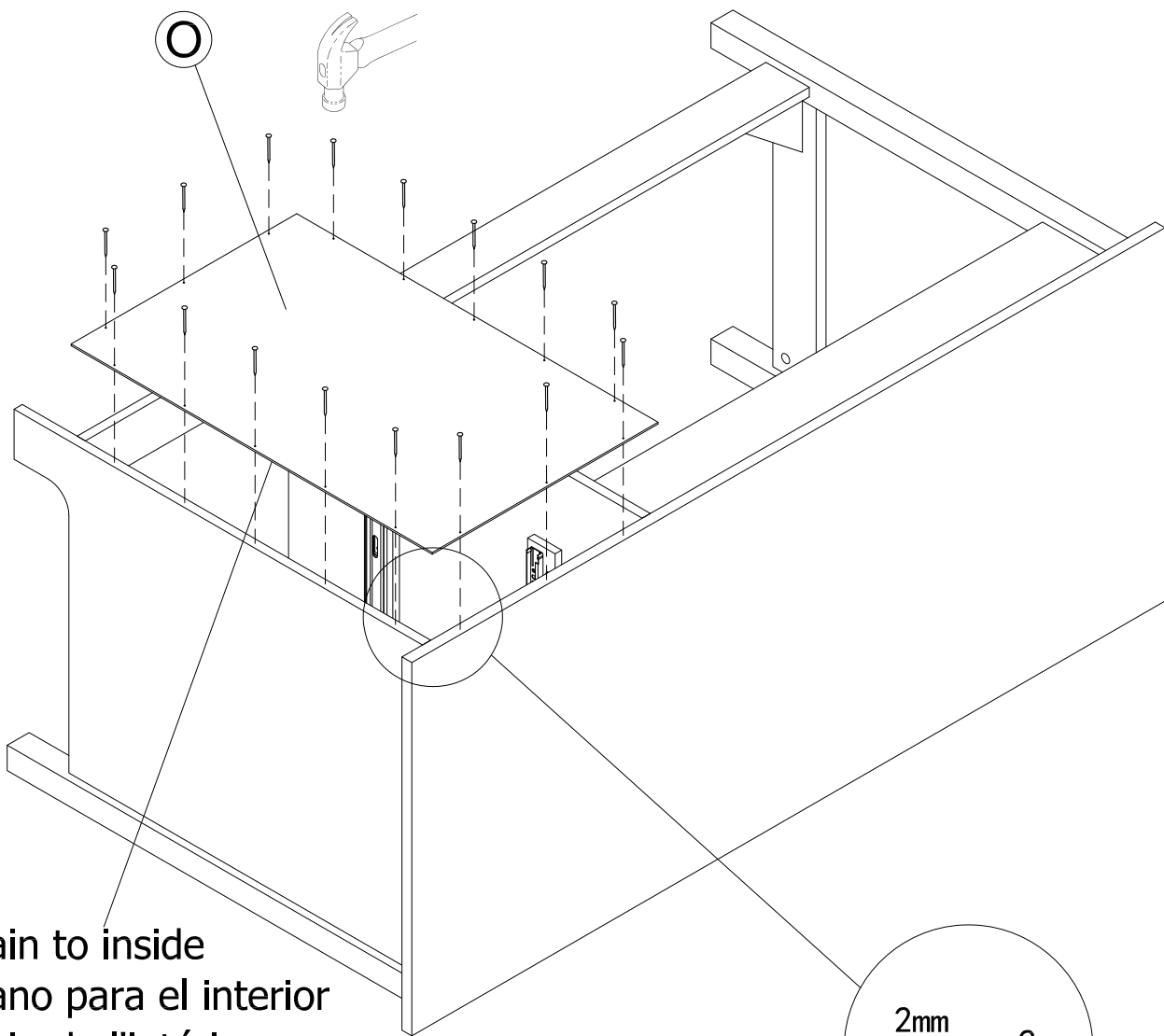

Grain to inside  
Grano para el interior  
Grain de l'intérieur

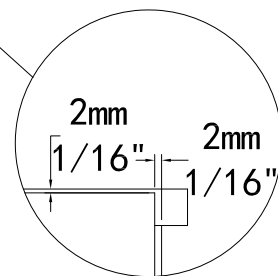

**STEP 17**

H100446



[ 2 ]

Drawer Bracket

H100445

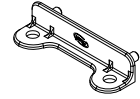

[ 2 ]

Drawer Bracket

H35251

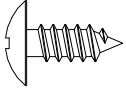

[ 8 ]

#10 x 1/2"

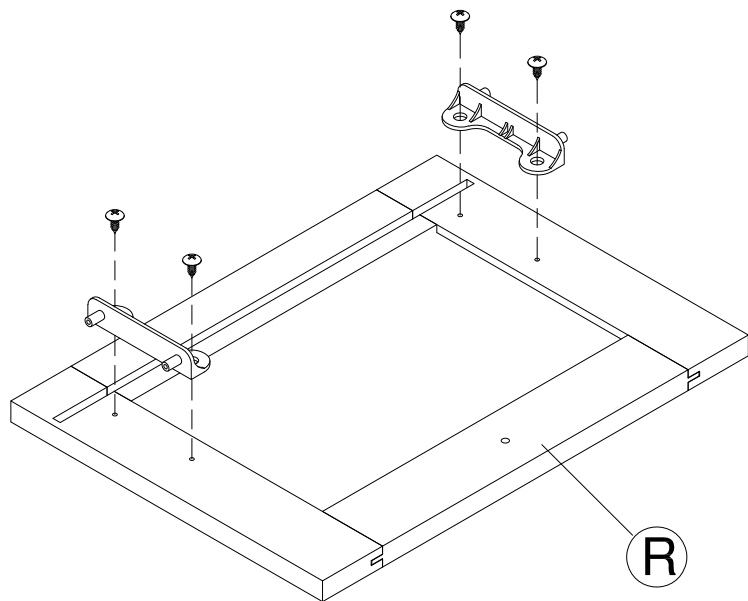
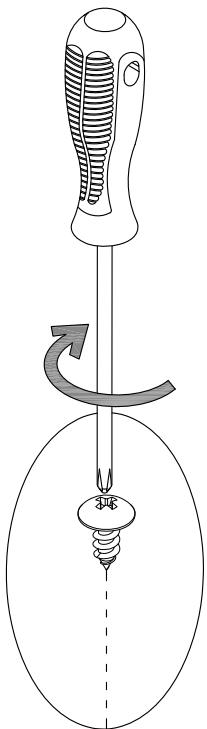
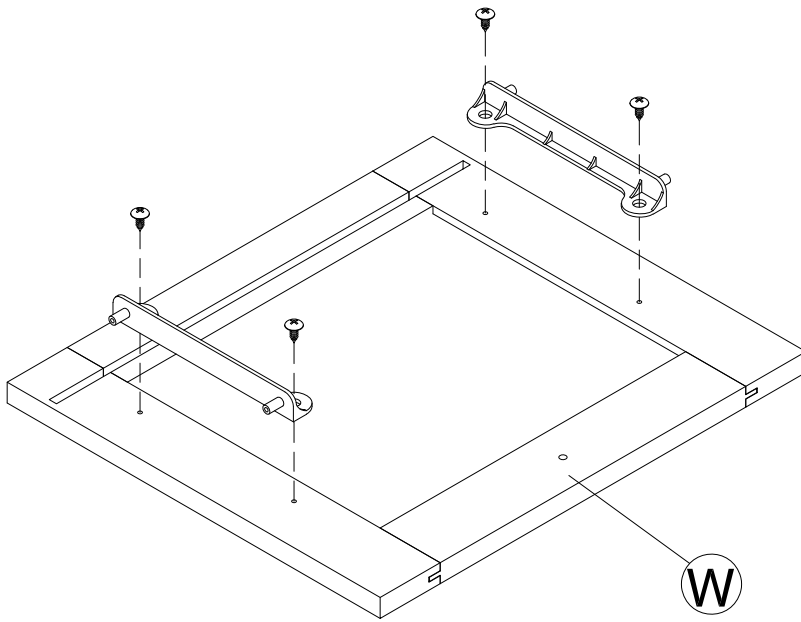

**STEP 18**

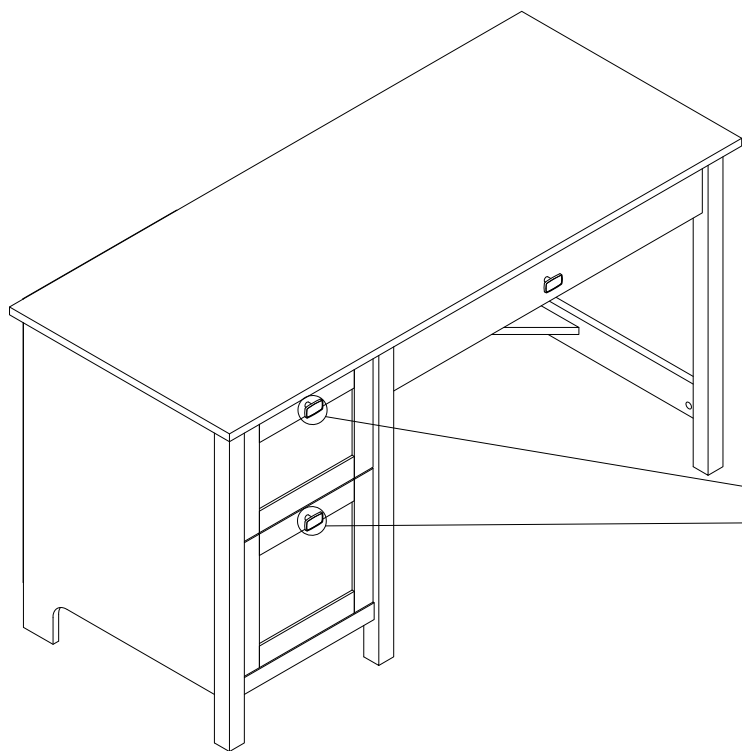

**Go to step 19**  
**Proceda al paso 19**  
**Allez a l'etape 19**

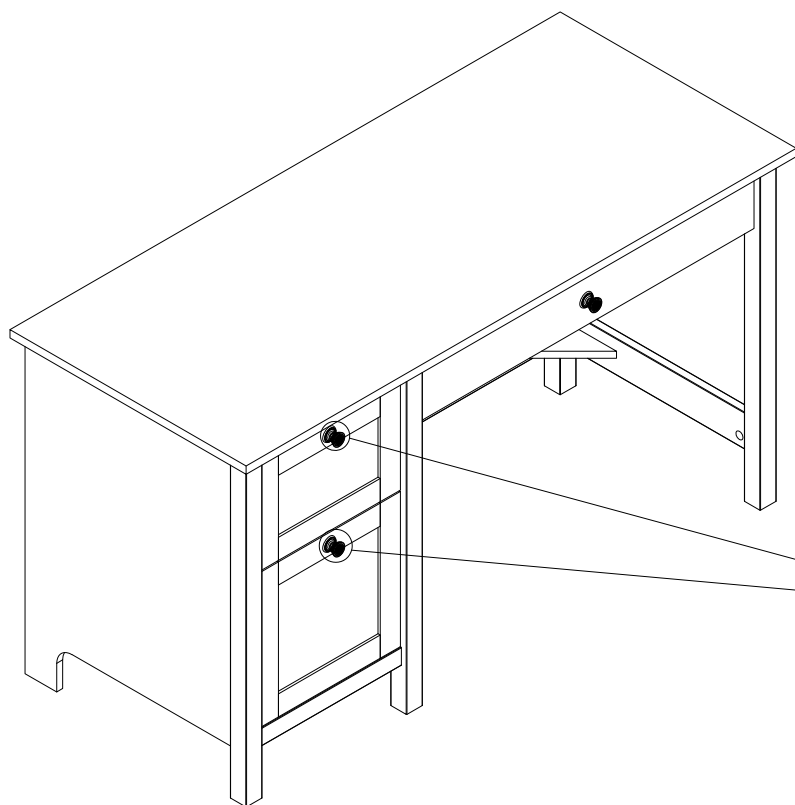
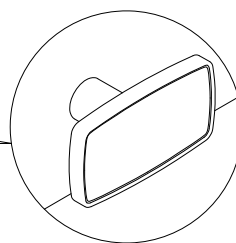

**Go to step 21**  
**Proceda al paso 21**  
**Allez a l'etape 21**

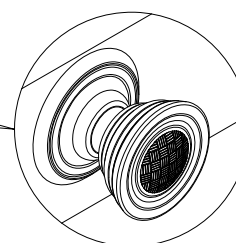

# STEP 19

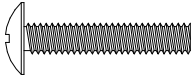
H160460  [ 1 ]  
M4 x 22mm

H175335  [ 1 ]  
Handle

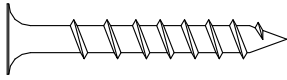
H23198  [ 4 ]  
#10 x 1-1/2"

H101725  [ 4 ]  
#6 x 1/2"

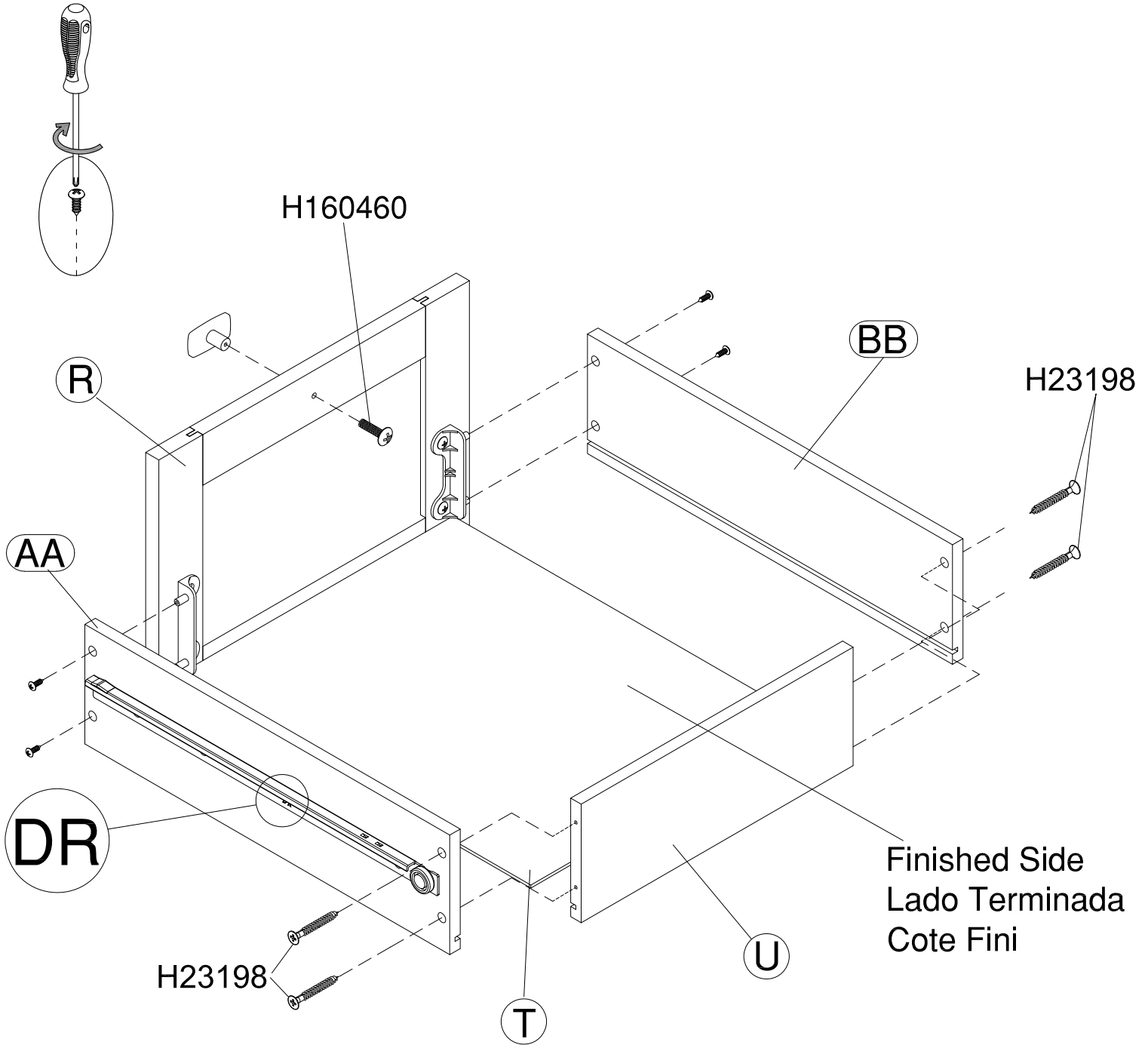

**STEP 20**

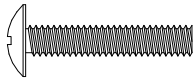
H160460  [ 1 ]  
M4 x 22mm

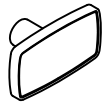
H175335  [ 1 ]  
Handle

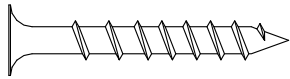
H23198  [ 4 ]  
#10 x 1-1/2"

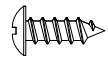
H101725  [ 4 ]  
#6 x 1/2"

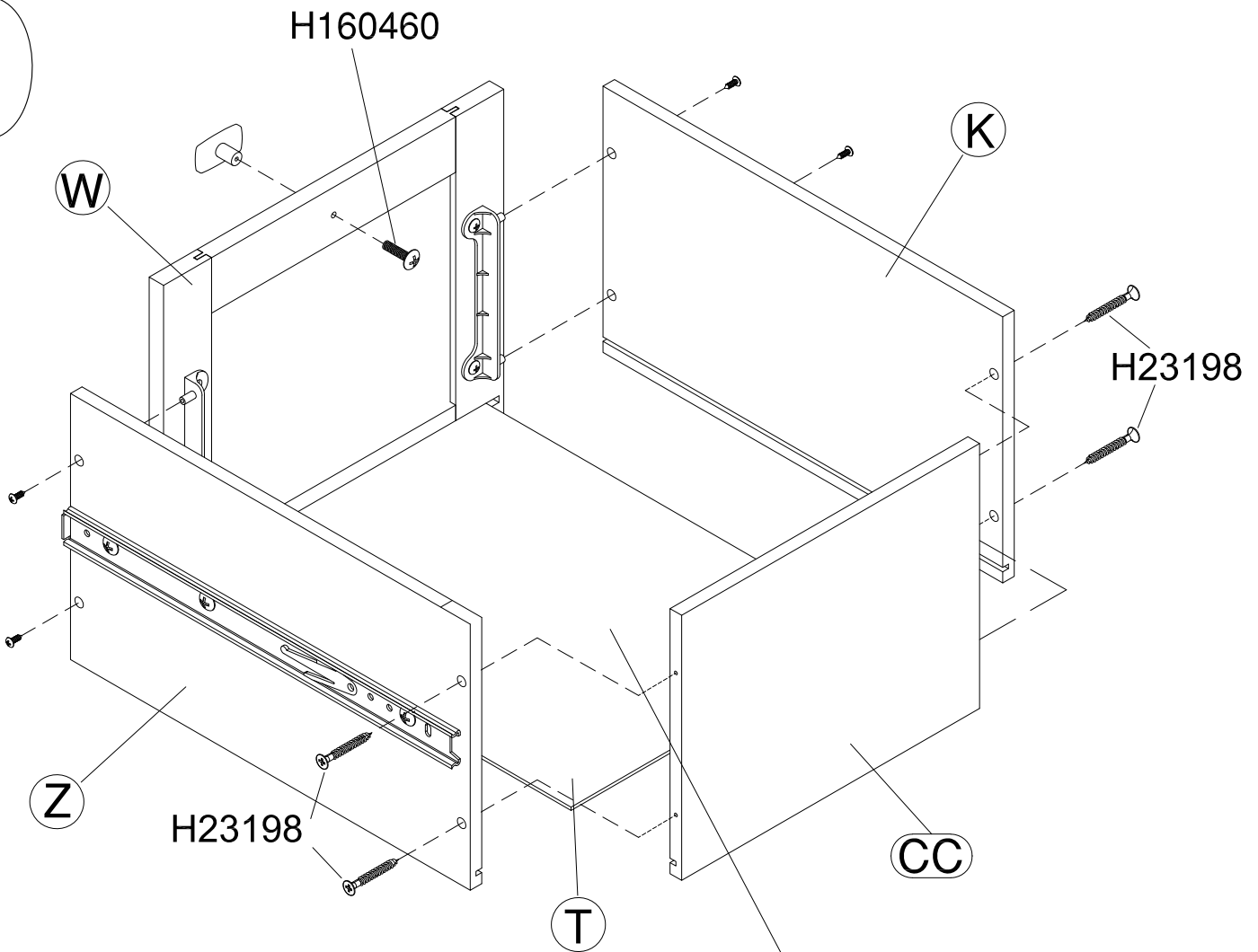
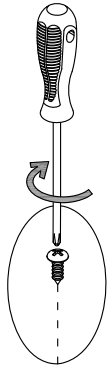

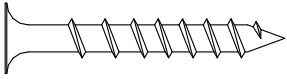

Finished Side  
Lado Terminada  
Cote Fini

**STEP 21**

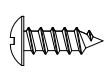
H23198  [ 4 ]  
#10 x 1-1/2"

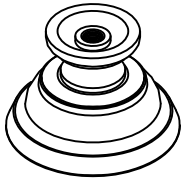
H101725  [ 4 ]  
#6 x 1/2"

H174929  [ 1 ]  
Pull

H174930  [ 1 ]  
Knob Cap

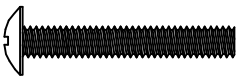
H157181  [ 1 ]  
#8-32 x 1-1/8"

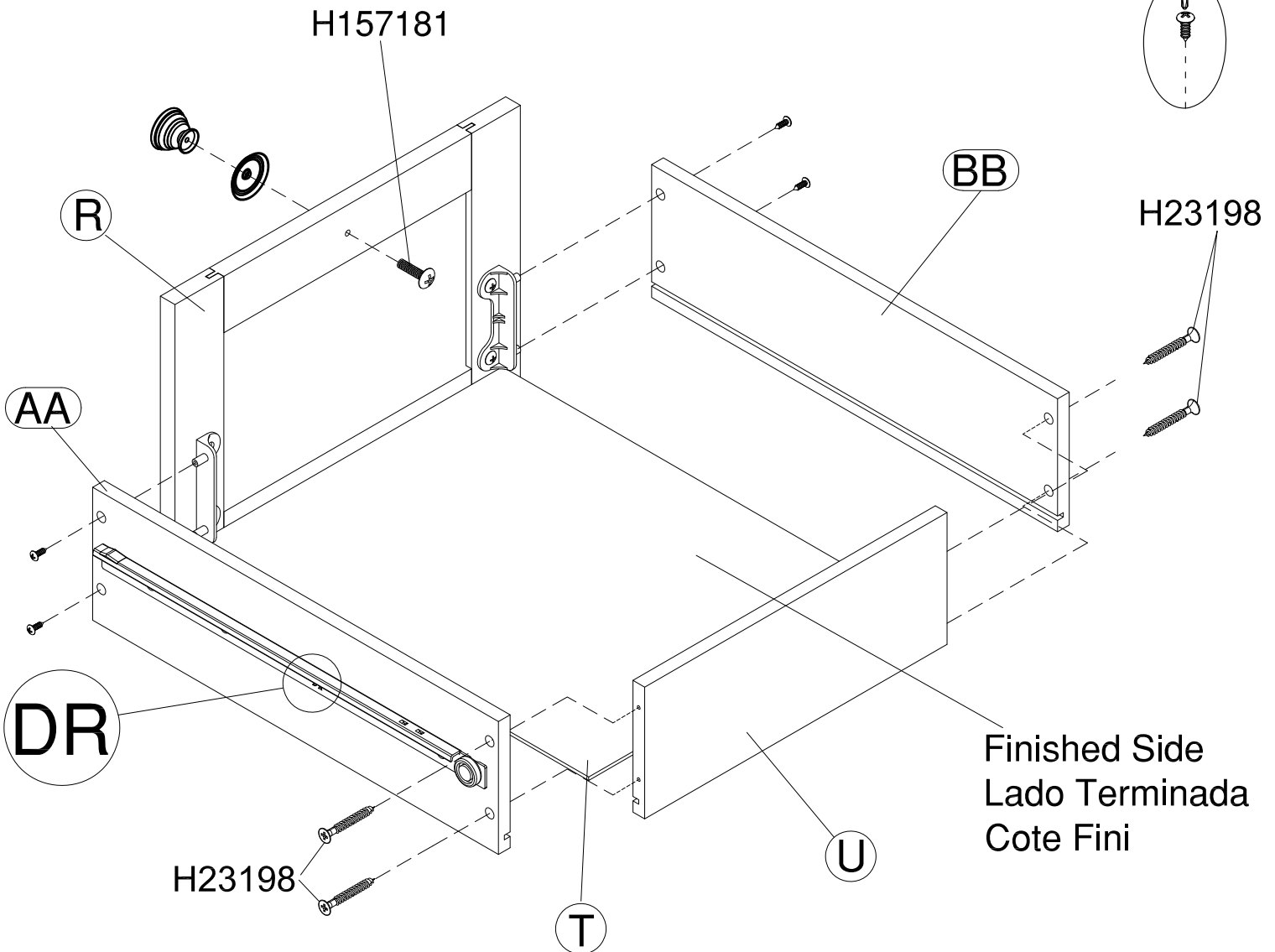
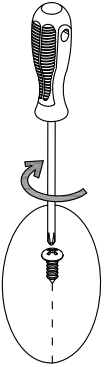

**STEP 22**

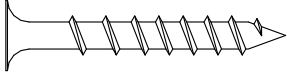
H23198  [ 4 ]  
#10 x 1-1/2"

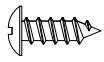
H101725  [ 4 ]  
#6 x 1/2"

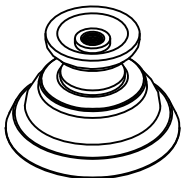
H174929  [ 1 ]  
Pull

H174930  [ 1 ]  
Knob Cap

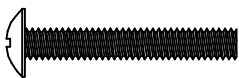
H157181  [ 1 ]  
#8-32 x 1-1/8"

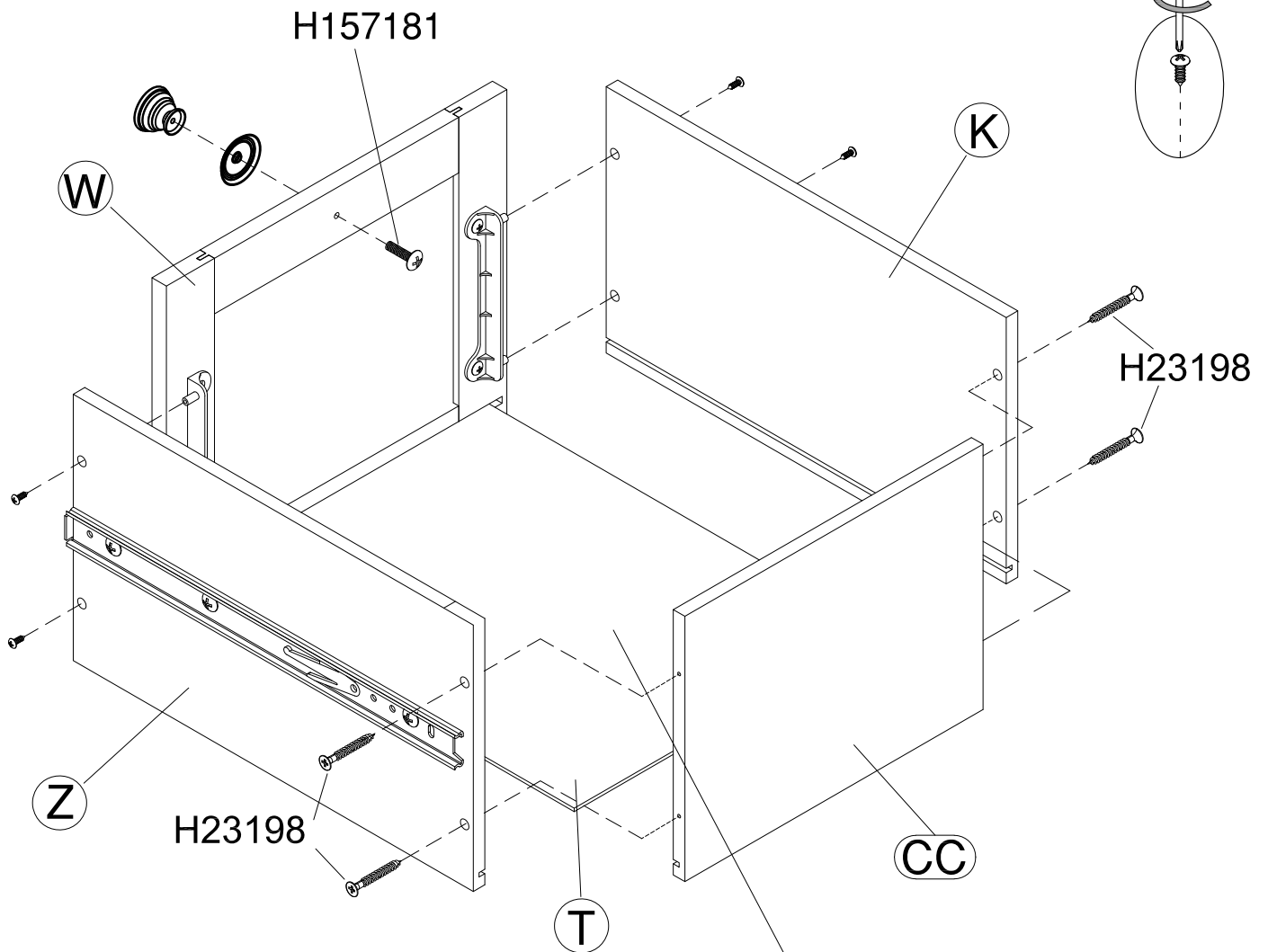
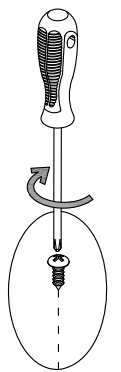

Finished Side  
Lado Terminada  
Cote Fini

**STEP 23**

H89793

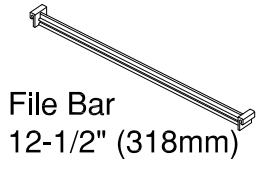

[ 1 ]

H158780

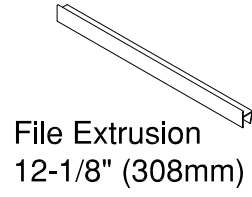

[ 1 ]

H162488

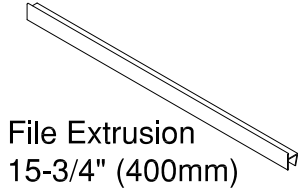

[ 2 ]

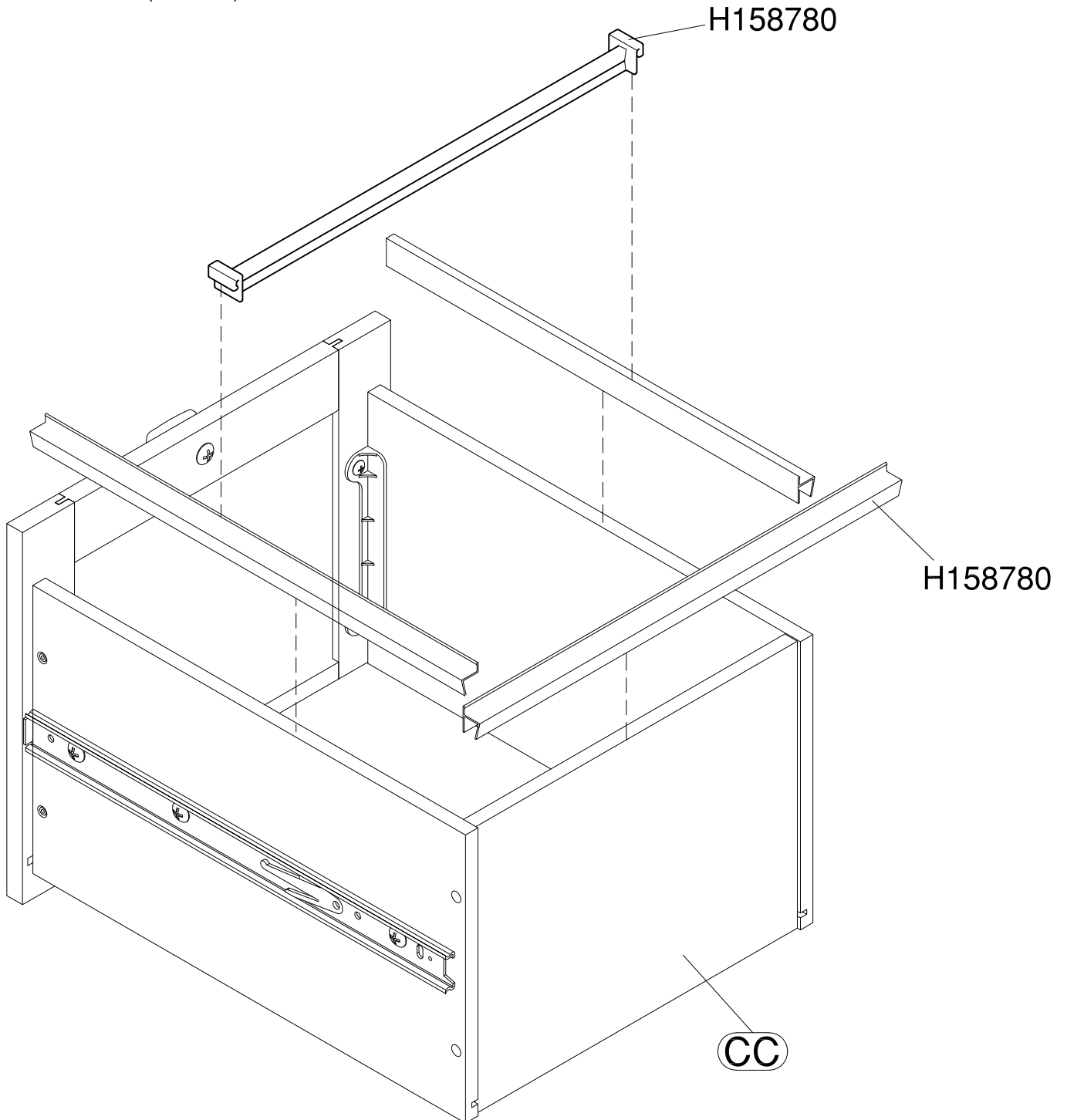

**STEP 24**

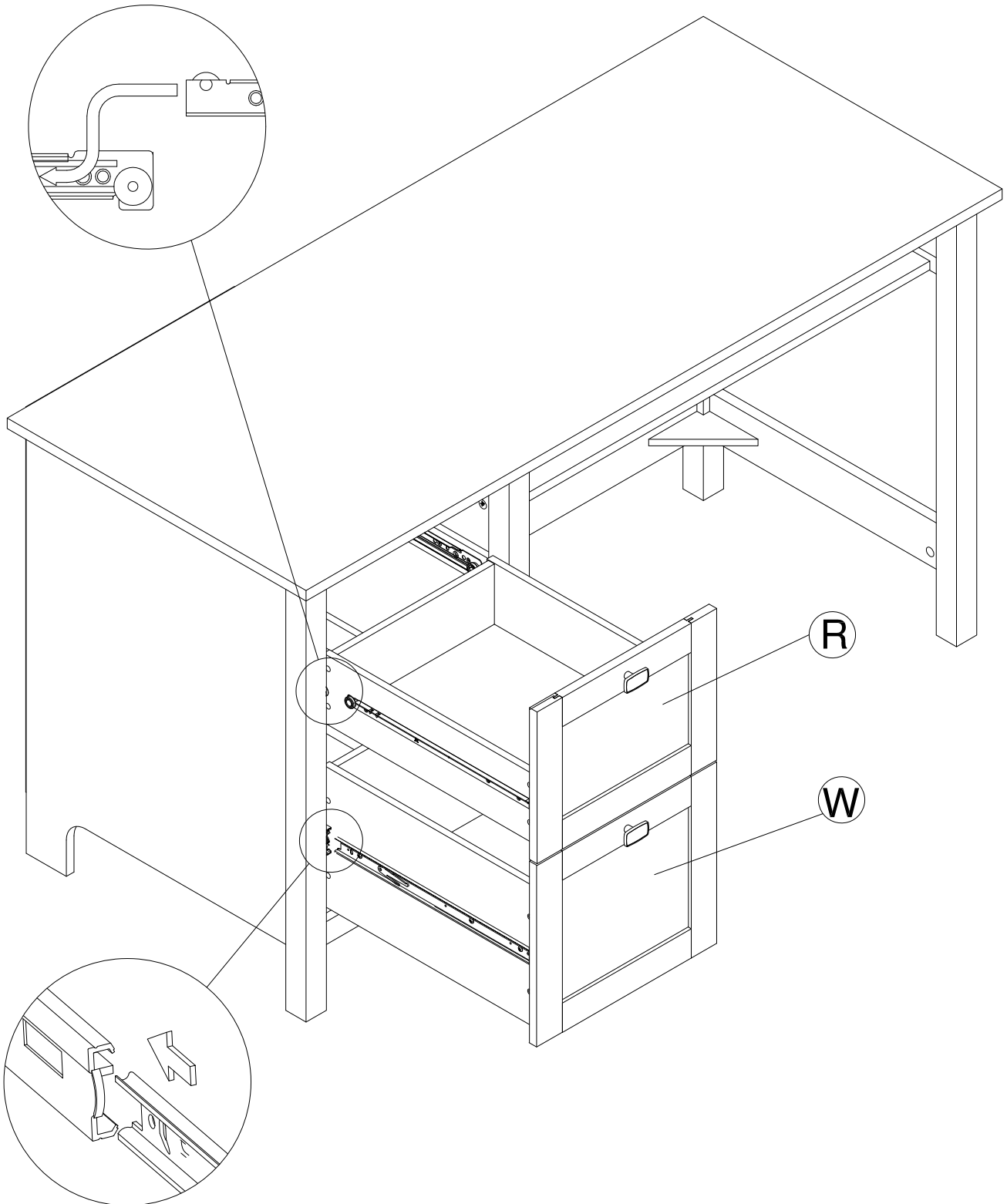

**STEP 25**

H72550

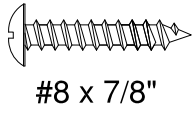

[ 4 ]

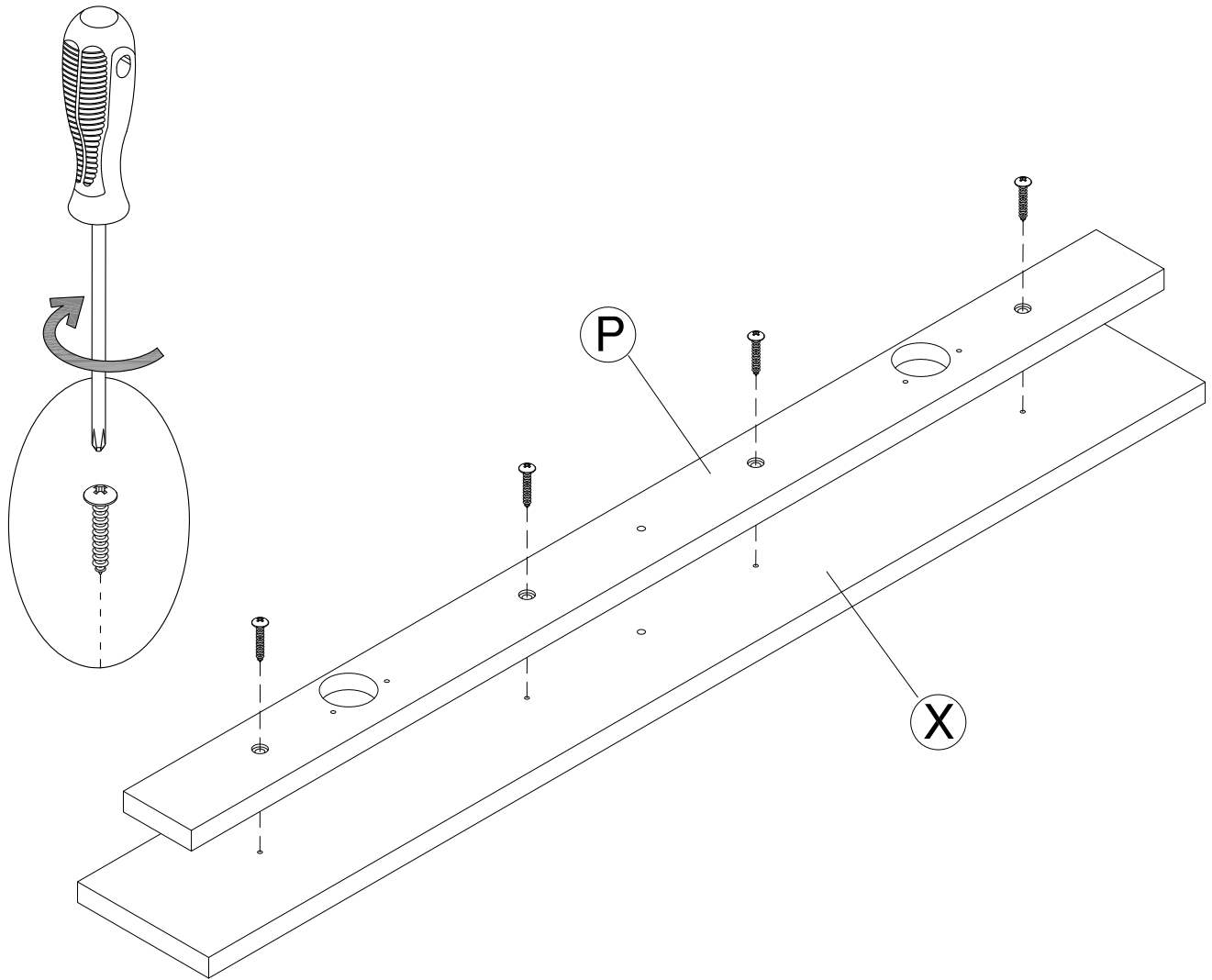

STEP 26

H153242

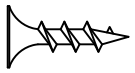

[ 4 ]

#8 x 5/8"

H180675

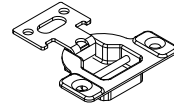

Hinge

[ 2 ]

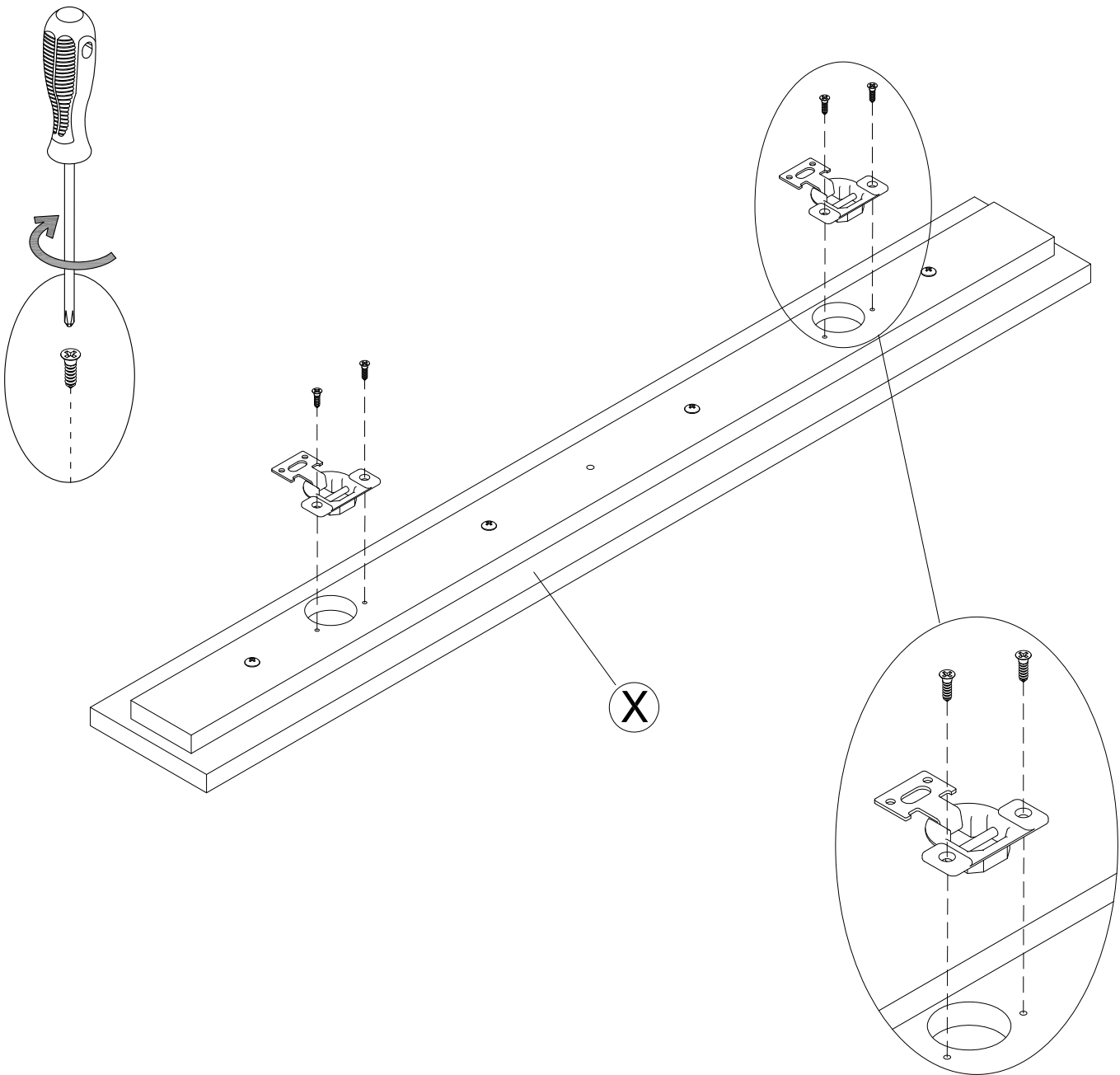

**STEP 27**

H38169

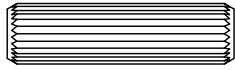

[ 6 ]

Wood Dowel  
8 x 30mm

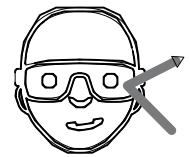
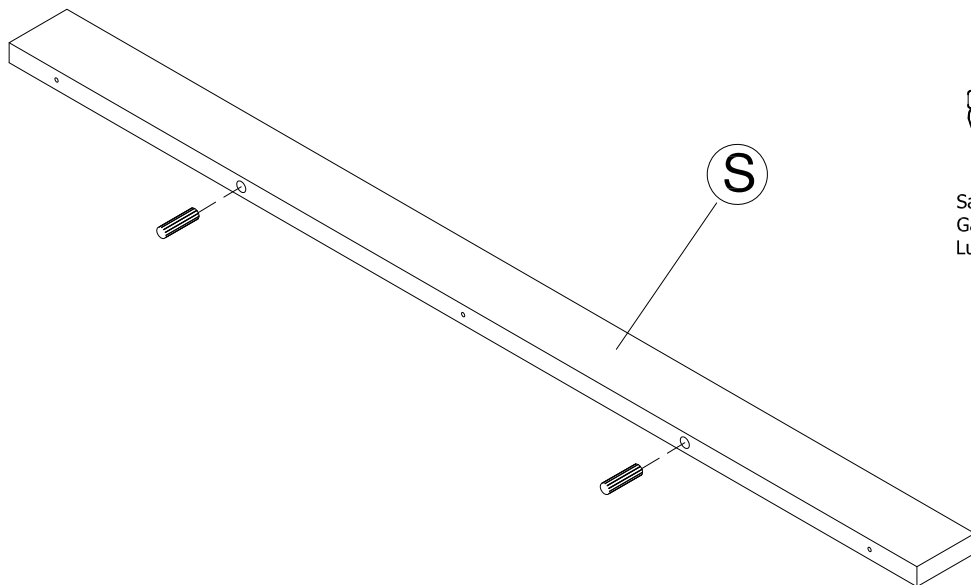
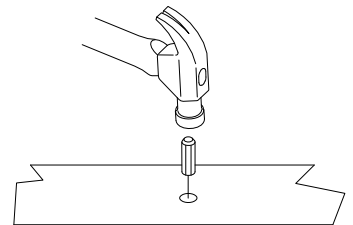
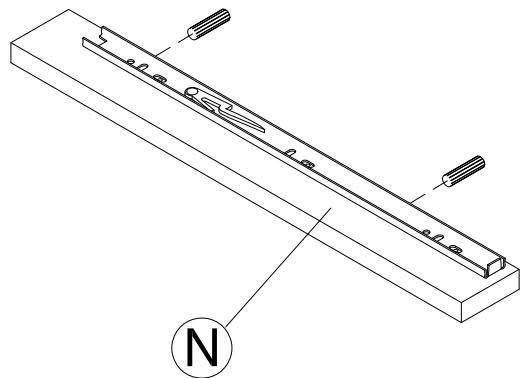
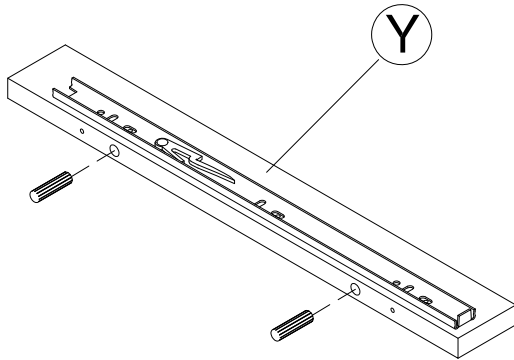

Safety glasses  
Gafas de seguridad  
Lunettes de protection

# STEP 28

H23198

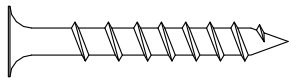

[ 7 ]

#10 x 1-1/2"

Finished side  
Borde terminado  
Cote fini

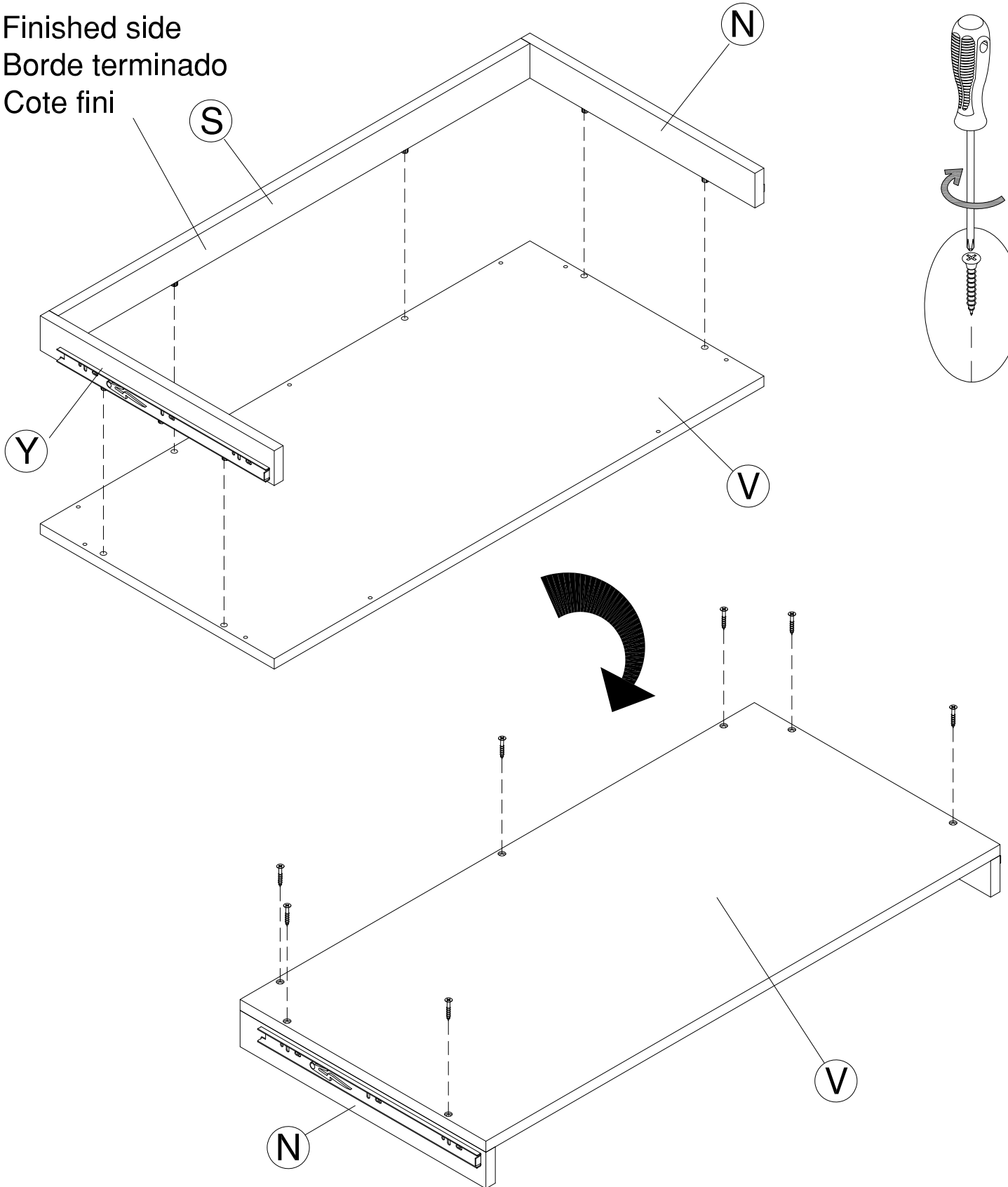

**STEP 29**

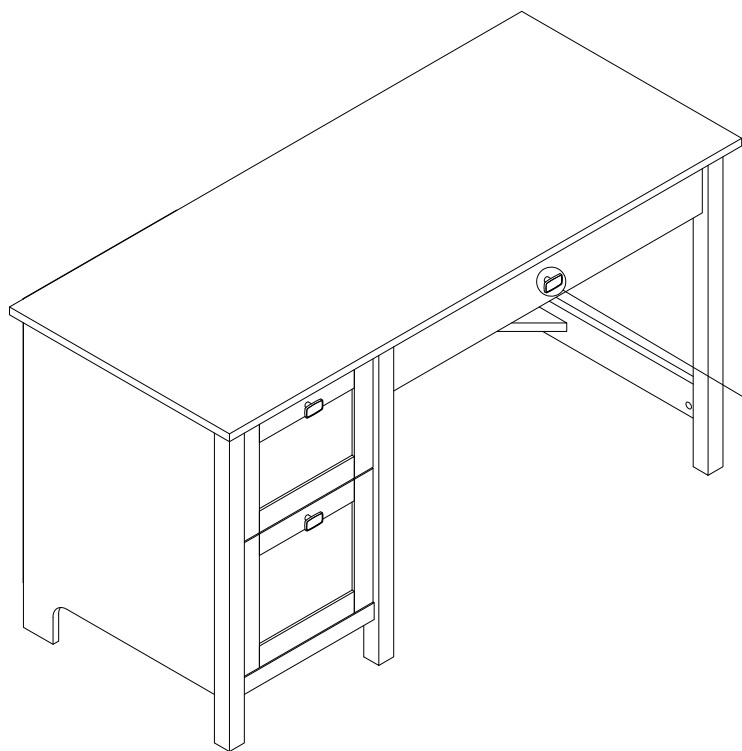

**Go to step 30**  
**Proceda al paso 30**  
**Allez a l'etape 30**

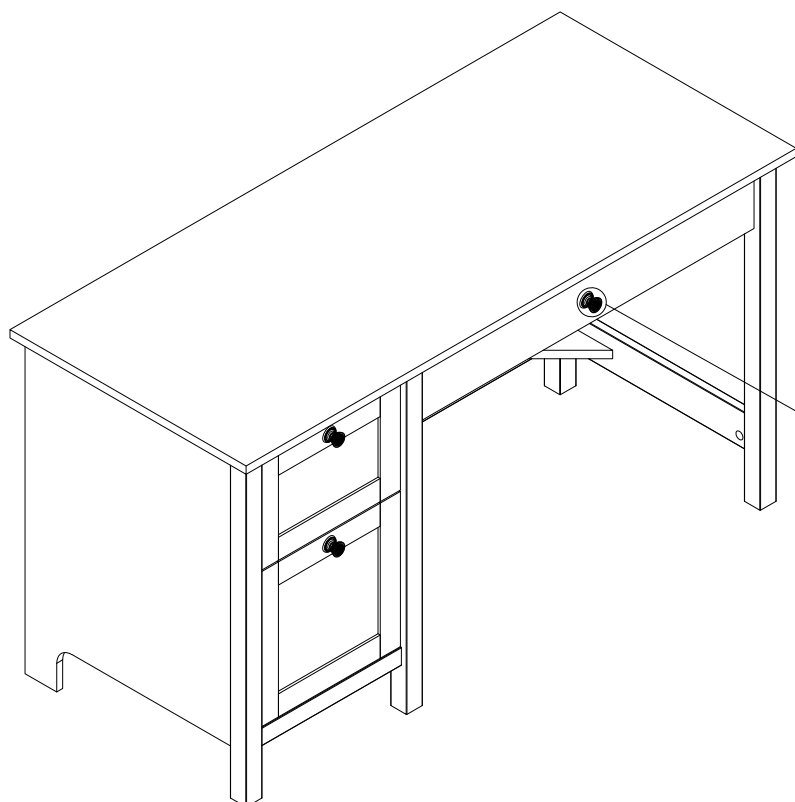
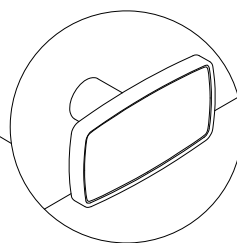

**Go to step 31**  
**Proceda al paso 31**  
**Allez a l'etape 31**

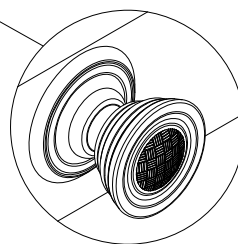

STEP 30

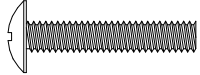
H160460  [ 1 ]  
M4 x 22mm

H175335  [ 1 ]  
Handle

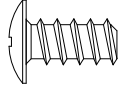
H146988  [ 2 ]  
#12 x 1/2"

H180671  [ 2 ]  
Bumper  
Ø12x6mm

An assistant is required.  
Es necesario un ayudante.  
Un assistant est nécessaire.

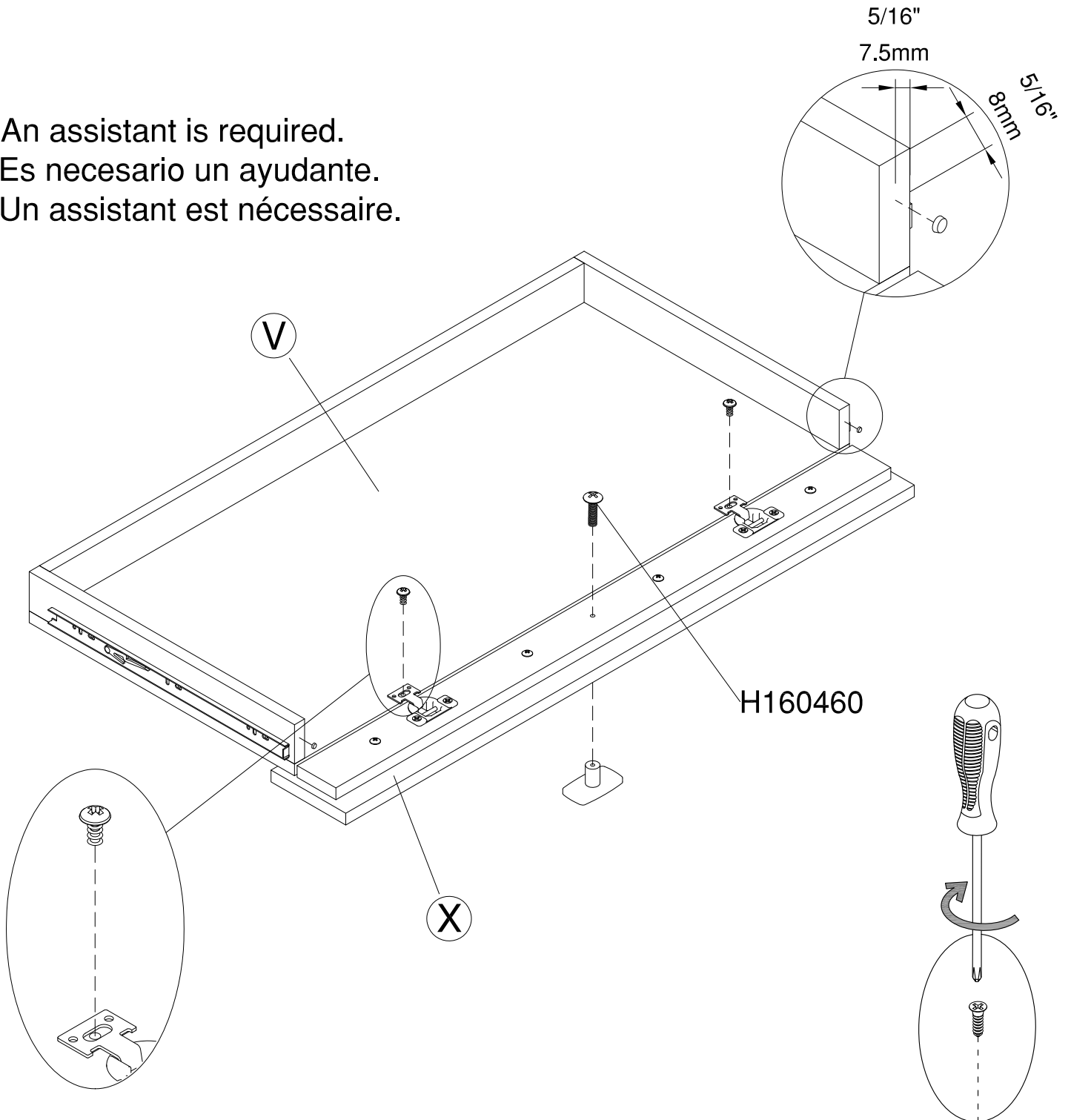

STEP 31

H146988 [ 2 ]  
#12 x 1/2"

H180671 [ 2 ]  
Bumper  
Ø12x6mm

H174929 [ 1 ]  
Pull

H174930 [ 1 ]  
Knob Cap

H157181 [ 1 ]  
#8-32 x 1-1/8"

An assistant is required.  
Es necesario un ayudante.  
Un assistant est nécessaire.

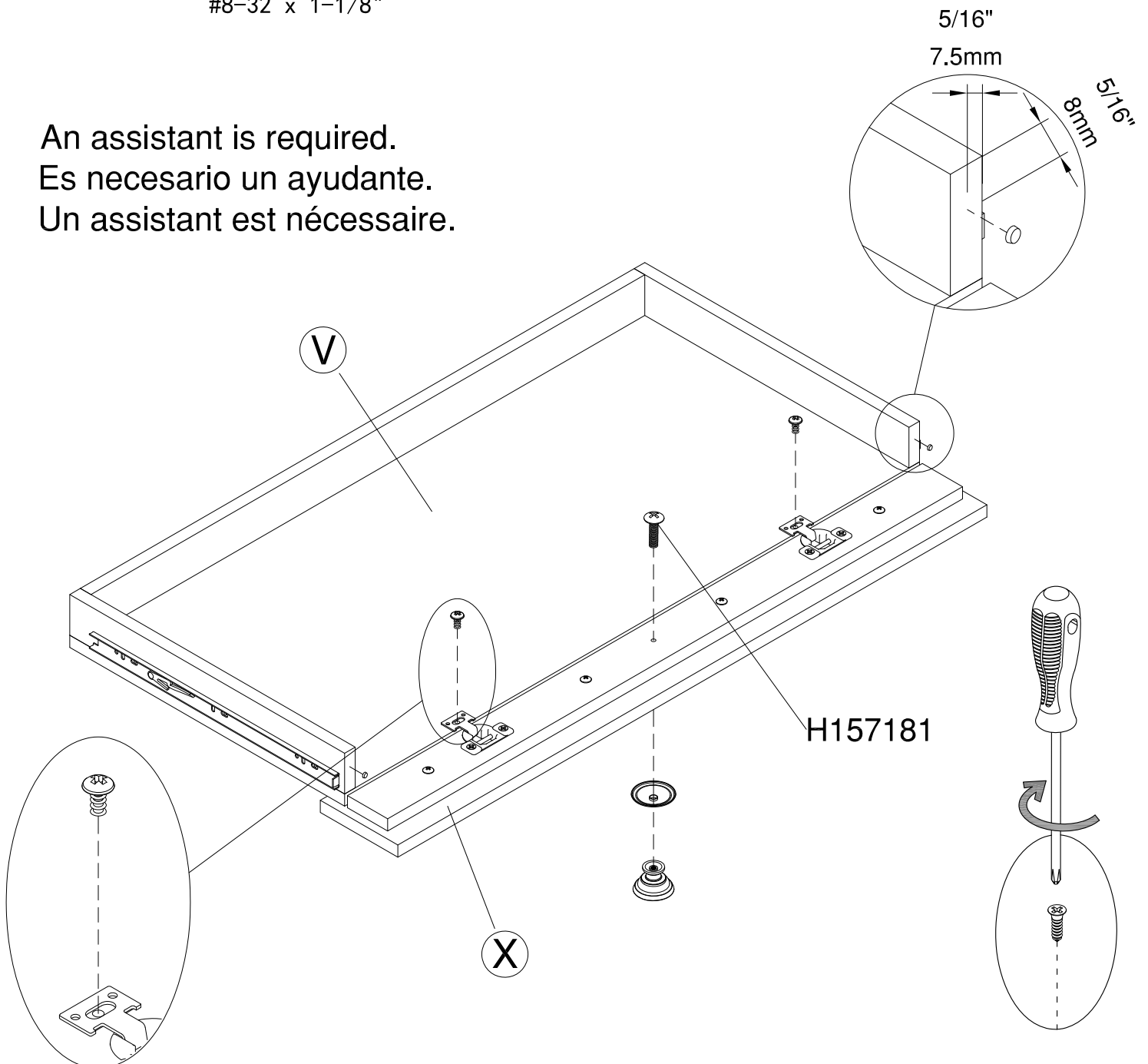

**STEP 32**

---

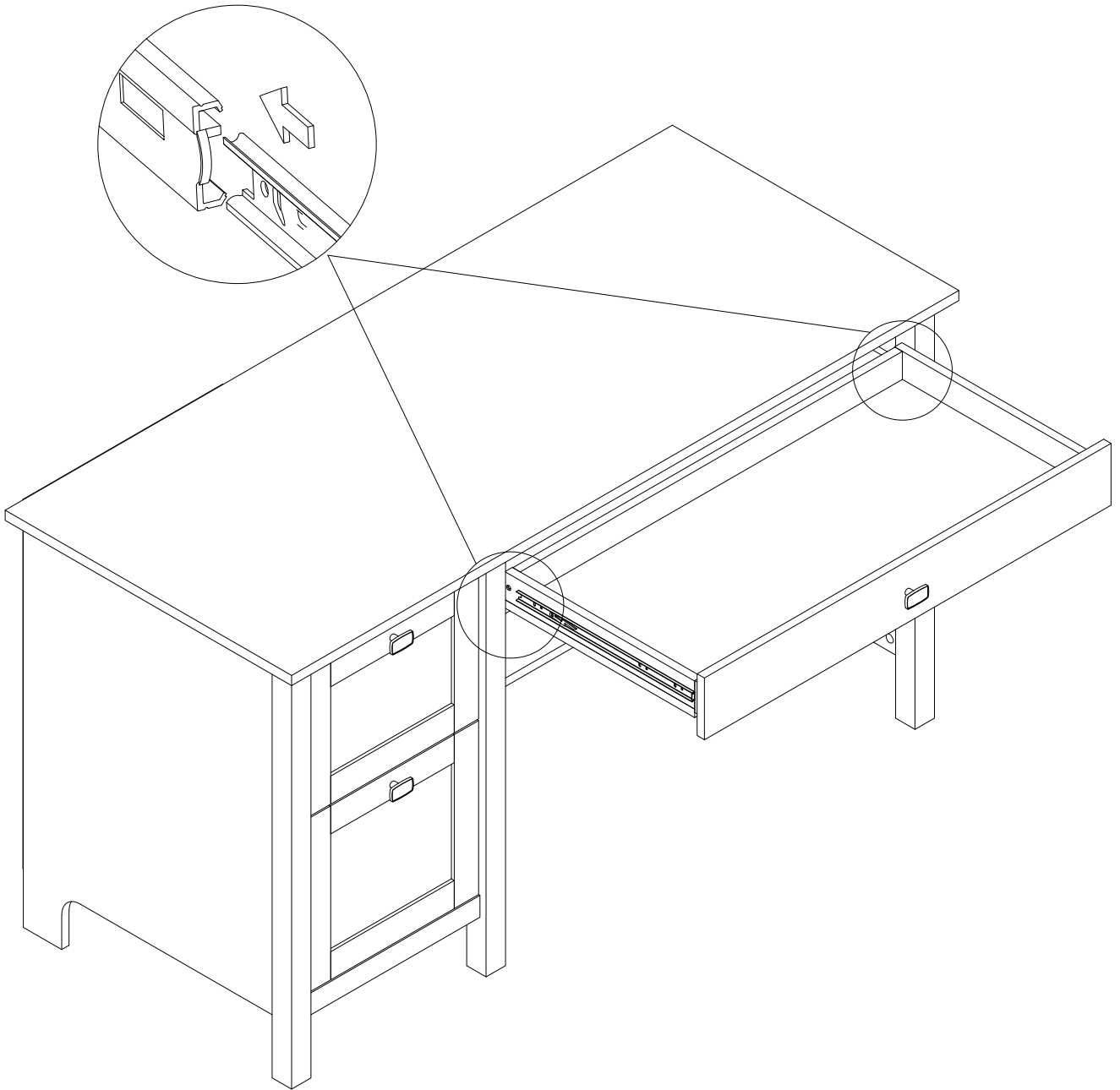

## STEP 33

### DRAWER FRONT VIEW

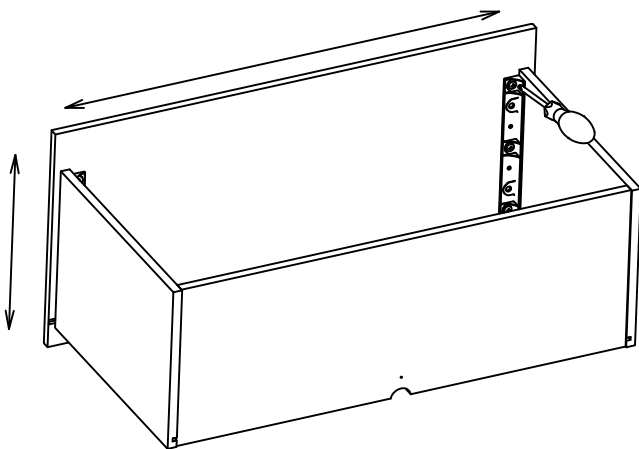
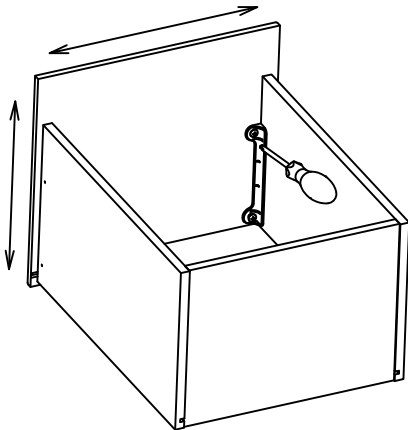
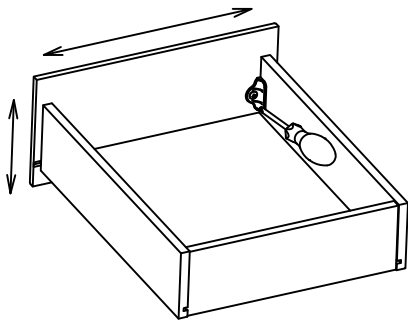
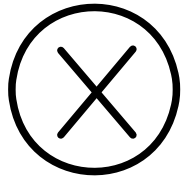
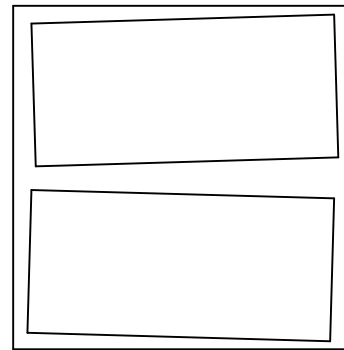
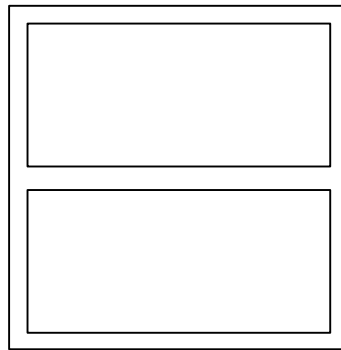

REQUIRED TOOL: PHILLIPS SCREWDRIVER

HERRAMIENTA REQUERIDA: DESTORNILLADOR PHILLIPS  
OUTIL REQUIS: TOURNEVIS CRUCIFORME

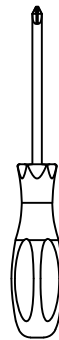

1. LOOSEN SCREWS.
2. ADJUST DRAWER FRONTS.
3. TIGHTEN SCREWS.

1. Afloje los tornillos
2. Ajustar frentes de cajón
3. Apriete los tornillos

1. Desserrer les vis
2. Ajuster les façades des tiroirs
3. Serrer les vis

# WARRANTY INFORMATION/INFORMATIONS POUR LA GARANTIE/INFORMACIÓN DE GARANTÍA

## WRITTEN WARRANTY TO YOU

In order to provide you with timely assistance, please thoroughly inspect your furniture for missing or defective parts immediately after opening the carton. You will also need your sales receipt or other proof of purchase. Replacement part(s) will be shipped to you at no charge with assuming all ship-ping and handling charges.

This product is warranted to the original purchaser at the time of purchase and for a period of one year thereafter.

We warrant to you, the original purchaser, that our furniture and all its parts and components are free of defects in material or workmanship. "Defects," as used in this warranty, is defined as any imperfection which impairs the use of the furniture product.

Our warranty is expressly limited to the replacement of furniture parts and components. For one year after the date of purchase, we will replace any parts that are defective in material or workmanship.

This warranty applies under conditions of normal use. Our products are not intended for outdoor use. This warranty does not cover: 1) defects caused by improper assembly or disassembly; 2) defects occurring after purchase due to product modification, intentional damage, accident, misuse, abuse, negligence or exposure to the elements; and 3) labor or assembly costs.

IMPLIED WARRANTIES, INCLUDING THE WARRANTY OF MERCHANTABILITY, SHALL NOT EXTEND BEYOND THE DURATION OF THE WRITTEN WARRANTY STATED ABOVE, AND IN NO EVENT SHALL BE LIABLE FOR INCIDENTAL OR CONSEQUENTIAL DAMAGES RESULTING FROM USE OF THE PRODUCT. Some states do not allow a limitation on how long an implied warranty lasts or the exclusion or limitation of incidental or consequential damages, so the above limitation and exclusion may not apply to you.

This warranty gives you specific legal rights. You may also have other rights that may vary from state to state.

## VOTRE GARANTIE

Afin de vous assister rapidement, veuillez inspecter votre mobilier en détail immédiatement après l'ouverture du carton en cas de pièces manquantes ou défectueuses. Vous aurez également besoin de votre reçu ou d'une autre preuve d'achat. La (les) pièce(s) de rechange vous sera (seront) envoyée(s) sans frais, Industries se chargeant de tous les frais d'expédition.

Tout le produit est garanti à l'acheteur original à partir de la date d'achat pour une période d'un an.

Nous vous garantissons, à vous l'acheteur original, que notre mobilier et toutes ses pièces et composants sont sans défaut de matériau ou de fabrication. Le terme "défauts" utilisé dans cette garantie, est défini comme étant toutes les imperfections qui compromettent l'utilisation du meuble.

Notre garantie est expressément limitée au remplacement des pièces et des composants du mobilier. Pendant un an après la date d'achat, remplacera toute pièce défectueuse dans le matériau ou sa fabrication.

Cette garantie d'applique sous des conditions d'utilisation normale. Nos produits ne sont pas destinés à être utilisés en plein air. Cette garantie ne couvre pas: 1) les défauts causés par un mauvais assemblage ou démontage, 2) les défauts ayant lieu après l'achat et dus à la modification du produit, des dommages intentionnels, des accidents, une mauvaise utilisation, un mauvais traitement, la négligence ou l'exposition aux éléments, et 3) les frais de main d'œuvre ou d'assemblage.

LES GARANTIES TACITES, Y COMPRIS LA GARANTIE DE QUALITE MARCHANDE, NE S'ETENDRONT PAS AU-DELA DE LA DUREE ECRITE CITEE CI-DESSUS, ET NE SERA EN AUCUN CAS RESPONSABLE DES DOMMAGES ACCESSOIRES OU INDIRECTS RESULTANT DE L'UTILISATION DU PRODUIT. Certains états ne permettent pas d'appliquer une limite à la durée de la garantie tacite, ni une exclusion ou limitation des dommages accessoires ou indirects; dans ce cas les limitations ou exclusion ci-dessus peuvent ne pas s'appliquer à vous.

Cette garantie vous donne des droits légaux spécifiques. Il se peut que vous ayez également d'autres droits qui peuvent varier d'un état à l'autre.

## GARANTIA ESCRITA DE PARA USTED

Para brindarle asistencia oportuna, por favor, verifique detalladamente que a su mueble no le falte o tenga piezas defectuosas inmediatamente después de abrir la caja. La(s) pieza(s) de reemplazo le será(n) enviada(s) sin recargo por Industrias asumiendo los gastos de envío y manipuleo.

Todo mueble es garantizado al comprador original al momento de la compra y por un periodo de uno año en adelante.

Le garantizamos a usted, el comprador original, que nuestros muebles sus partes y componentes están libres de defectos en materiales o trabajo. "Defectos", según se usa en esta garantía, se define como una imperfección que perjudica el uso del producto mobiliario.

Nuestra garantía se limita expresamente al reemplazo de partes y componentes mobiliarios. Durante uno año después de la fecha de compra, reemplazará cualquier parte defectuosa en material o trabajo.

Esta garantía se aplica bajo condiciones de uso normal. Nuestros productos de no son para uso en exteriores. Esta garantía no cubre: 1) defectos causados por un ensamblaje

o desensamblaje inadecuado; 2) defectos que ocurran después de la compra debido a modificación del producto, daño intencional, accidente, mal uso, abuso, negligencia o exposición a los elementos; y 3) costos de trabajo o ensamblaje.

LAS GARANTÍAS IMPLICADAS, INCLUYENDO LA GARANTÍA DE COMERCIABILIDAD, NO SE EXTENDERÁN MÁS ALLÁ DE LA DURACIÓN DE LA GARANTÍA ESCRITA MENCIONADA, Y EN NINGÚN CASO SERÁ RESPONSABLE POR DAÑOS INCIDENTALES O CONSIGUIENTES COMO RESULTADO DEL USO DEL PRODUCTO. Algunos estados no permiten una limitación sobre el tiempo de duración de la garantía implicada o la exclusión o limitación de daños incidentales o consiguientes, de manera que la limitación y exclusión mencionadas pueden no aplicarse para usted.

Esta garantía le otorga derechos legales específicos. Puede también tener otros derechos que pueden variar según los estados.