

# Rattan Nightstands

Product ID. 7ALBG



Scan for Support  
[support@garvee.com](mailto:support@garvee.com)



Distributed by  
**GARVEE**.com

SKU: PHK\_36S4NOLV

## Assembly instruction!

This package contains two sets of products . Follow the above installation steps to obtain both sets of products .

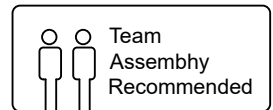
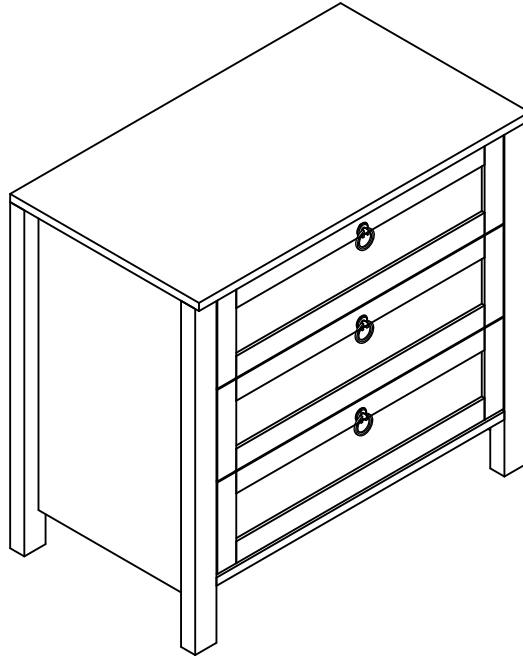

### Trouble shooting:

Missing/Wrong /Broken parts and installation issues



Send email with your question pic, order NO. and screenshot of order details to:  
[support@garvee.com](mailto:support@garvee.com)



Respond within 24 hours



Issue resolved

## Tips!



1. Check all the components & screws are intact before assembling .
  2. If you notice any pieces are missing or damaged please do not assemble and contact us immediately .
  3. **Please send an email with you order number and issues, we will respond within 24 hours.**
- Customer Service Team: [support@garvee.com](mailto:support@garvee.com)**

## Tools required

A Phillips head screw driver is required for the assembly of this product. (not included)  
Electric tool should not be used to assemble this product.

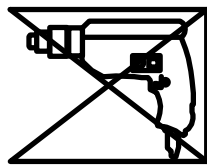
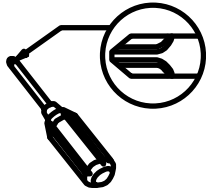

## Two people are needed



## IMPORTANT SAFETY INFORMATION

- Please carefully read the following instructions and caution warnings before assembling the product.
- Following this guide will ensure that you install, use and maintain the product properly.
- Please keep this installation and user manual/instructions for future reference in case you need to disassemble the product.
- Never allow children to climb onto the product. Ensure that you have special safety measures when children are around on their own.
- Be sure to check that all parts of the product are intact after you open the package.
- Do not assemble if you notice serious damage such as cracks or bends.
- During installation, please use work gloves for hand safety.
- Please assemble the unit on carpeted floor or the flat cardboard box to avoid scratching the surface or your floor while assembling on the floor.
- To assemble, please use the complimentary installation tools (Phillips screwdriver). Pay more attention to the direction of components at each steps.
- It is recommended that two people work together to assemble the product.

## RETURN POLICY

- Please contact us directly within 30 days after receiving.
- Ensure the product is in a good condition with the original box and all original certificates of purchase, manuals, and accessories attached.



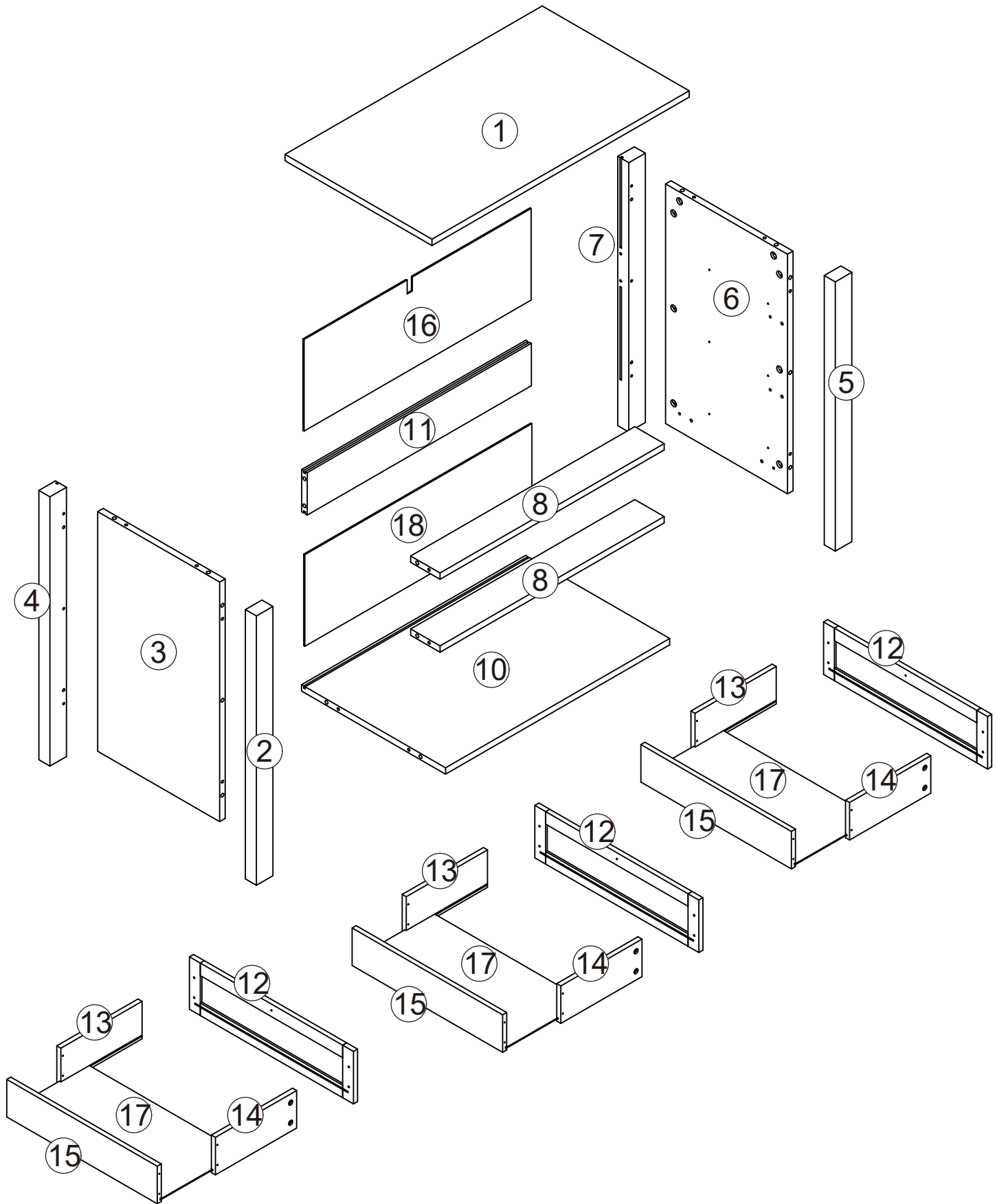

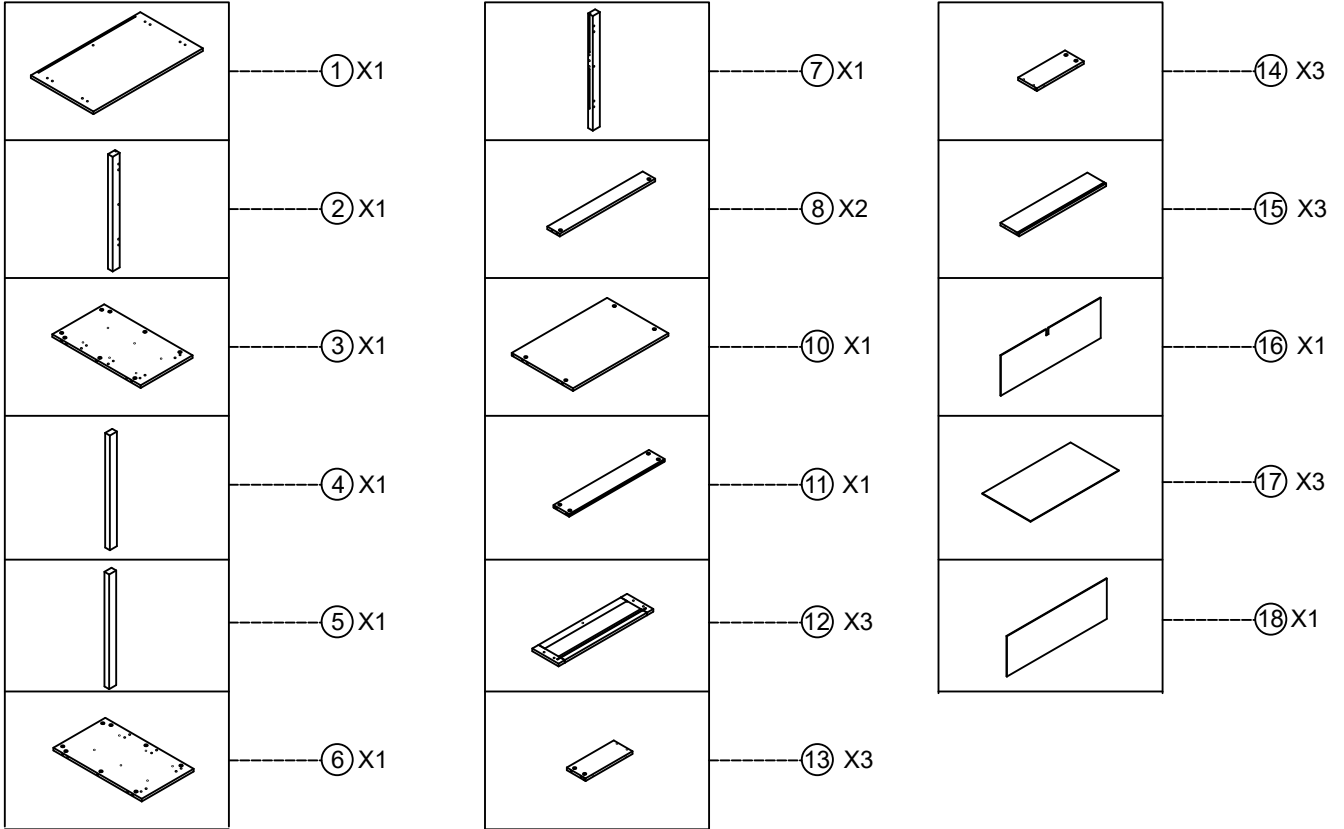

Please check that you have all the parts listed below



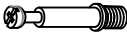





## Components:



## Screws & Tools:

Ⓐ		Ø6x35 mm	40pcs
Ⓑ		Ø15x9 mm	40pcs
Ⓒ		Ø6x30 mm	20pcs
Ⓓ		Ø3.5x12 mm	24pcs
Ⓔ			1pc
Ⓕ			1pc

Ⓖ		Ø3.5x35 mm	12pcs
Ⓕ		Ø4x18 mm	3pcs
Ⓖ			1pc
Ⓒ			3pcs
Ⓒ			3pcs
Ⓒ			3pcs
Ⓒ			3pcs

Check all the components & screws before assembly.  
Do not install in case part is missing, contact us to get.  
Send email with your question to [support@garvee.com](mailto:support@garvee.com).  
We will resend within 24 hours.

# Step 1

(A) x 12pcs

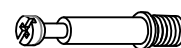

Ø6x35 mm  
CAM STUD

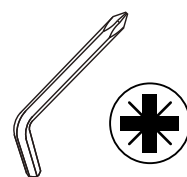
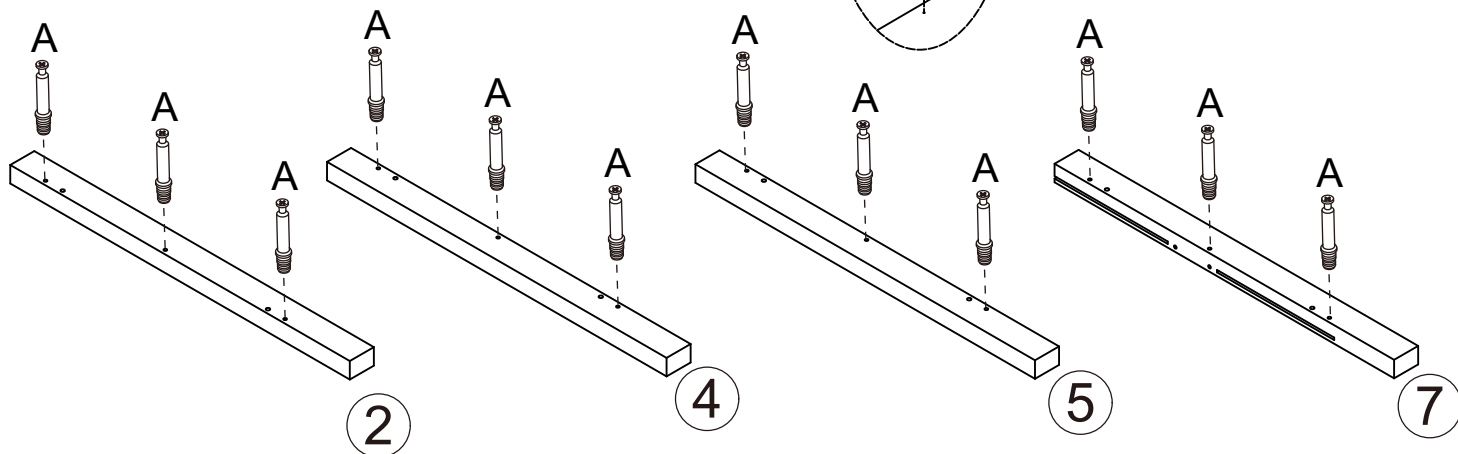
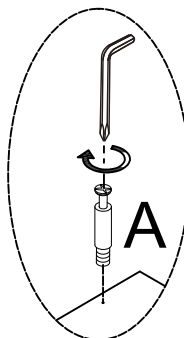

# Step 2

(B) x 12pcs



Ø15x9 mm  
CAM LOCK



(C) x 8pcs

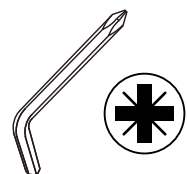
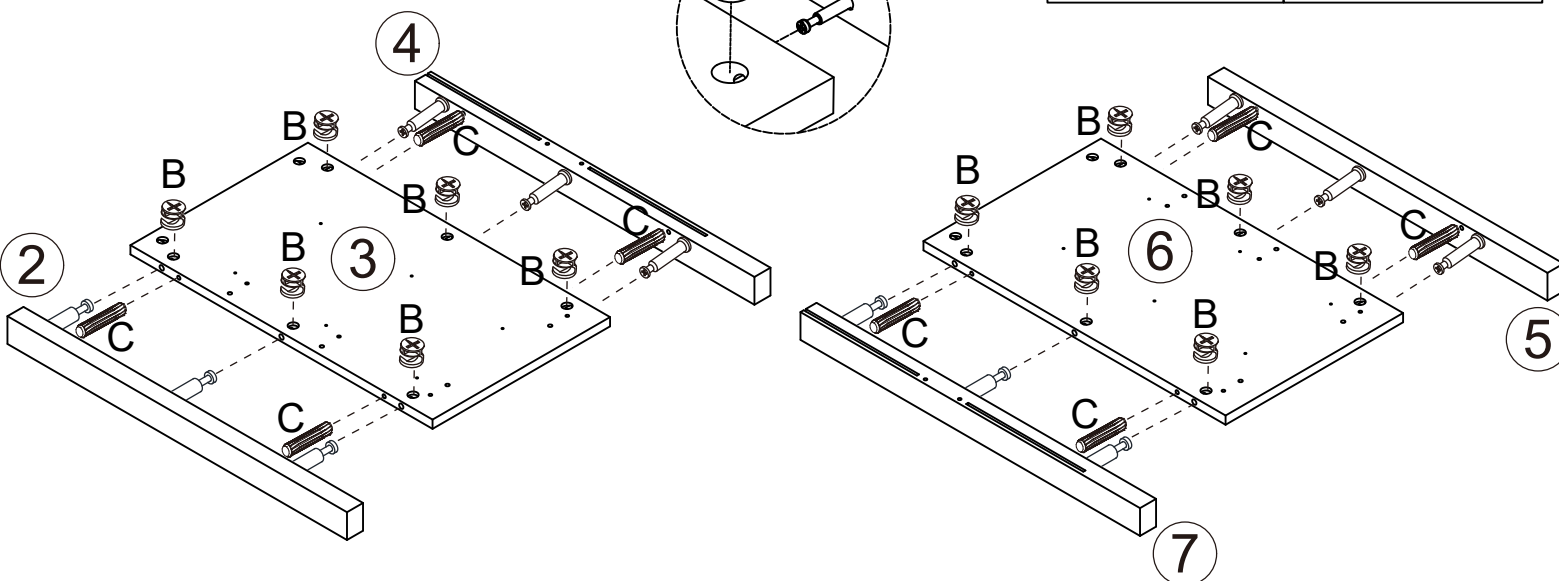
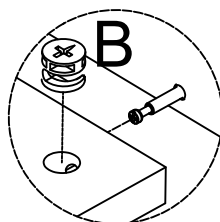

Ø6x30 mm DOWEL

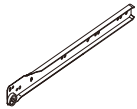
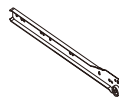

# Step 3

<p>CL x 3pcs</p> 	<p>CR x 3pcs</p> 	<p>D x 12pcs</p>  <p>Ø3.5x12 mm SCREW</p>
--	--	--

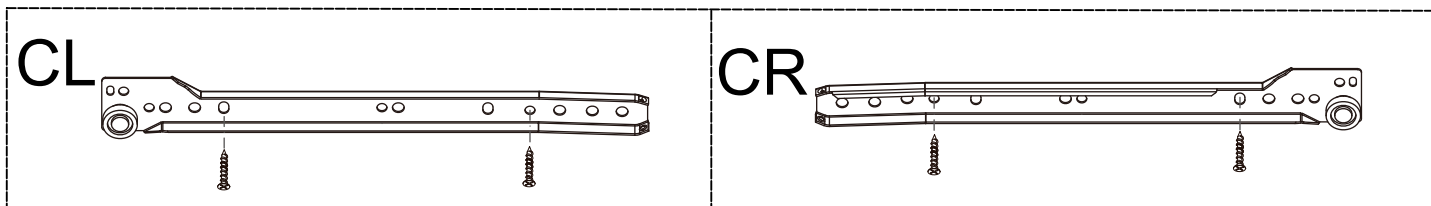

Noted this part is on the drawer front .

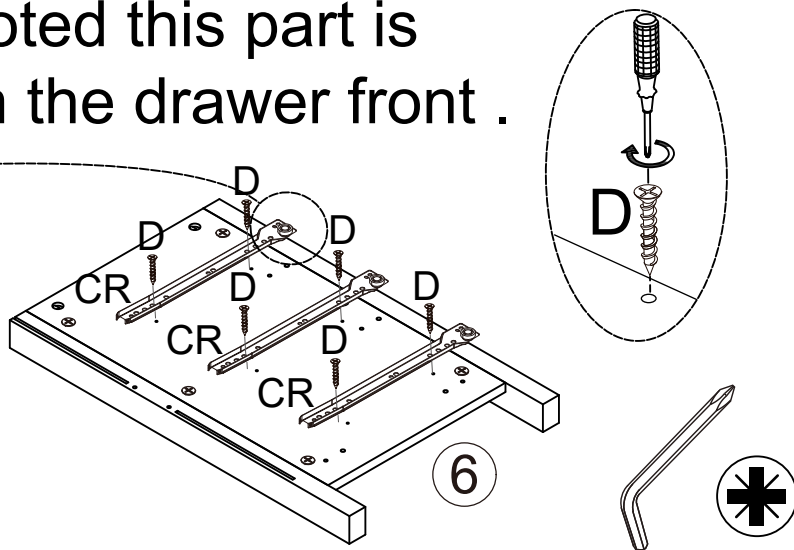
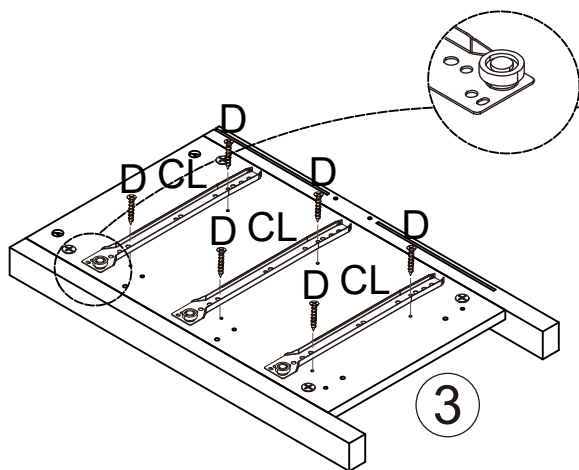

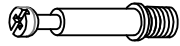

# Step 4

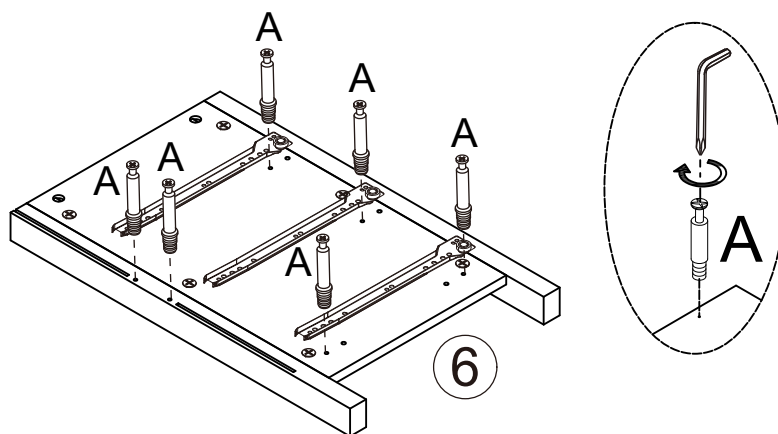
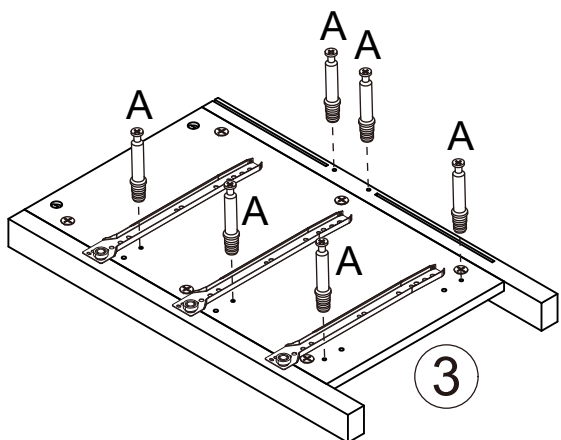
<p>A x 12pcs</p>  <p>Ø6x35 mm CAM STUD</p>
---



# Step 5

<b>(B) x 2pcs</b>  Ø15x9 mm CAM LOCK	<b>(C) x 2pcs</b>  Ø6x30 mm DOWEL
--	--

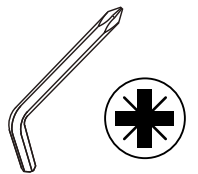
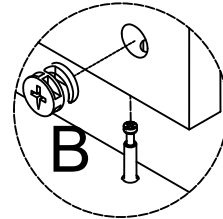
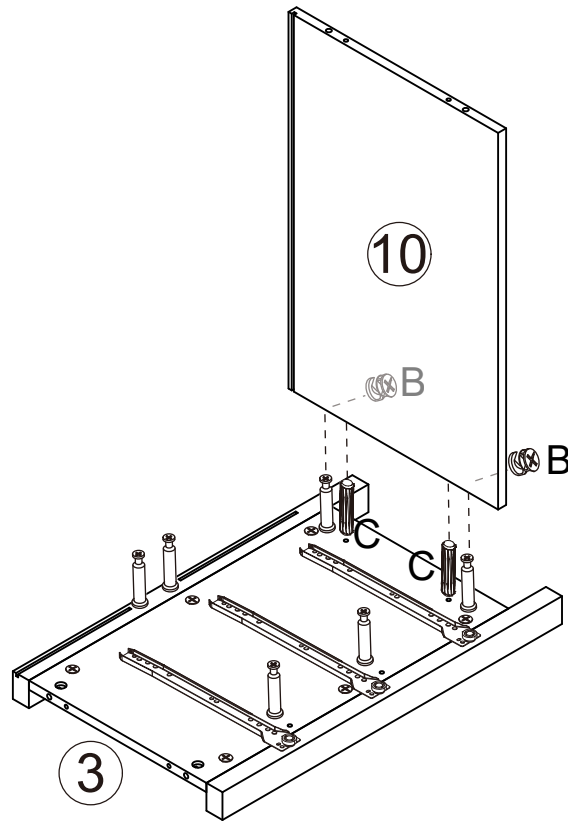

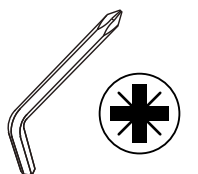
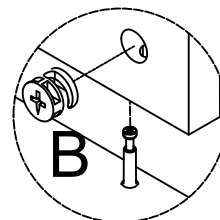
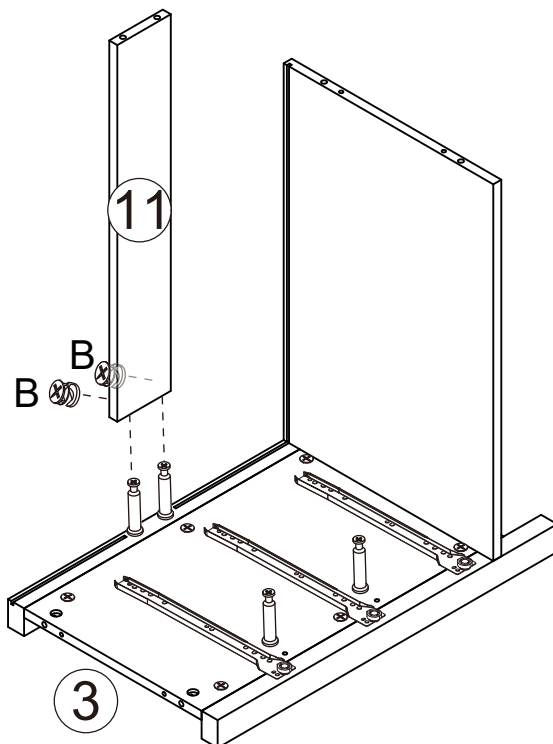

# Step 6

<b>(B) x 2pcs</b>  Ø15x9 mm CAM LOCK
--



# Step 7

<b>(B) x 2pcs</b>  Ø15x9 mm CAM LOCK	<b>(C) x 2pcs</b>  Ø6x30 mm DOWEL
--	--

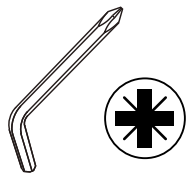
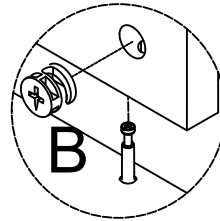
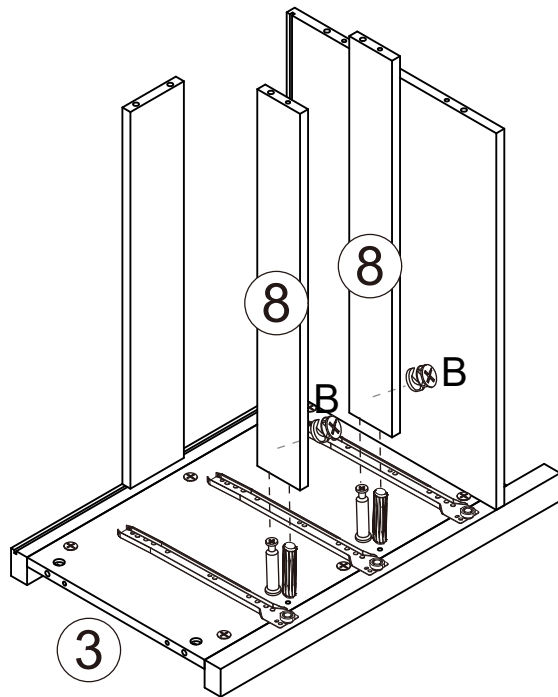

# Step 8

<b>(C) x 4pcs</b>  Ø6x30 mm DOWEL
--

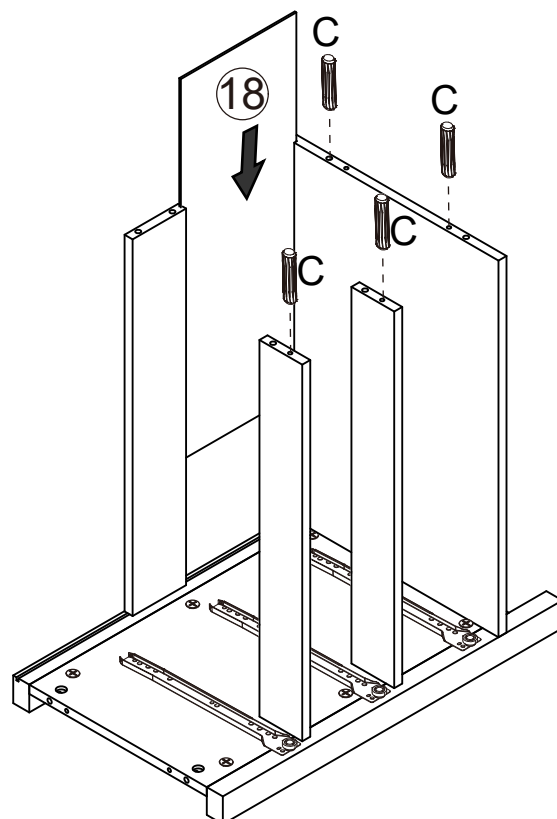

# Step 9

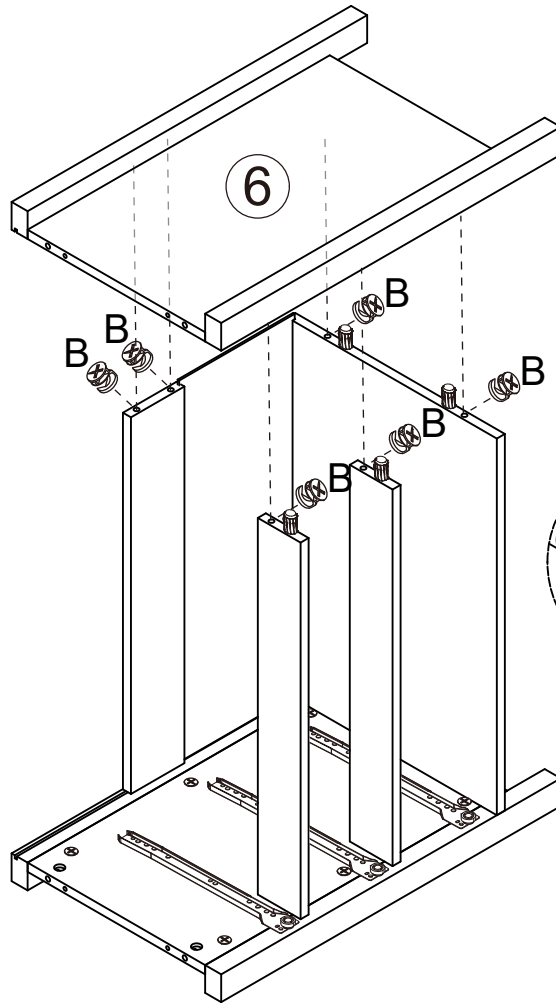



**(B) x 6pcs**

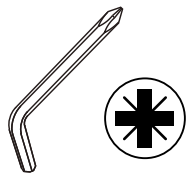
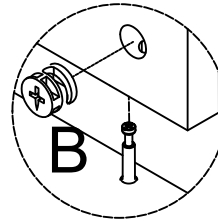

Ø15x9 mm  
CAM LOCK



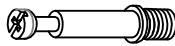

# Step 10

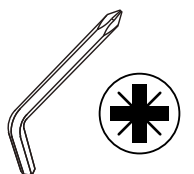
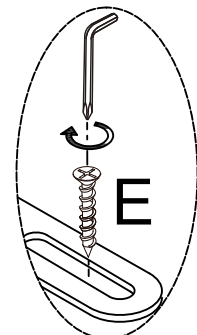
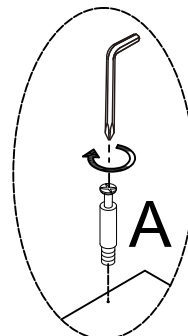
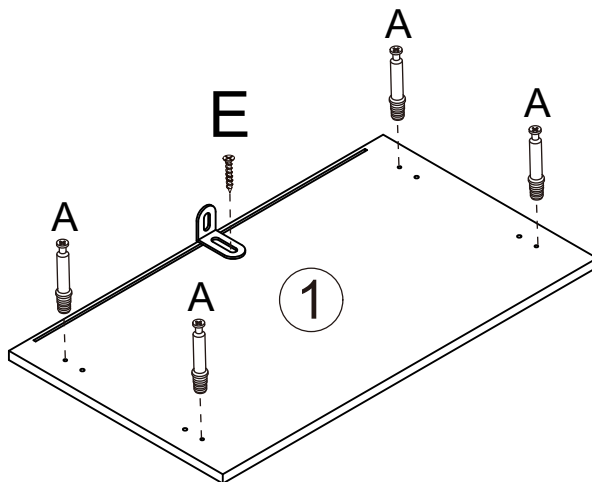
<p><b>(A) x 4pcs</b></p>  <p>Ø6x35 mm CAM STUD</p>	<p><b>(E) x 1pc</b></p>  <p>WALL PLUGS</p>
---	---

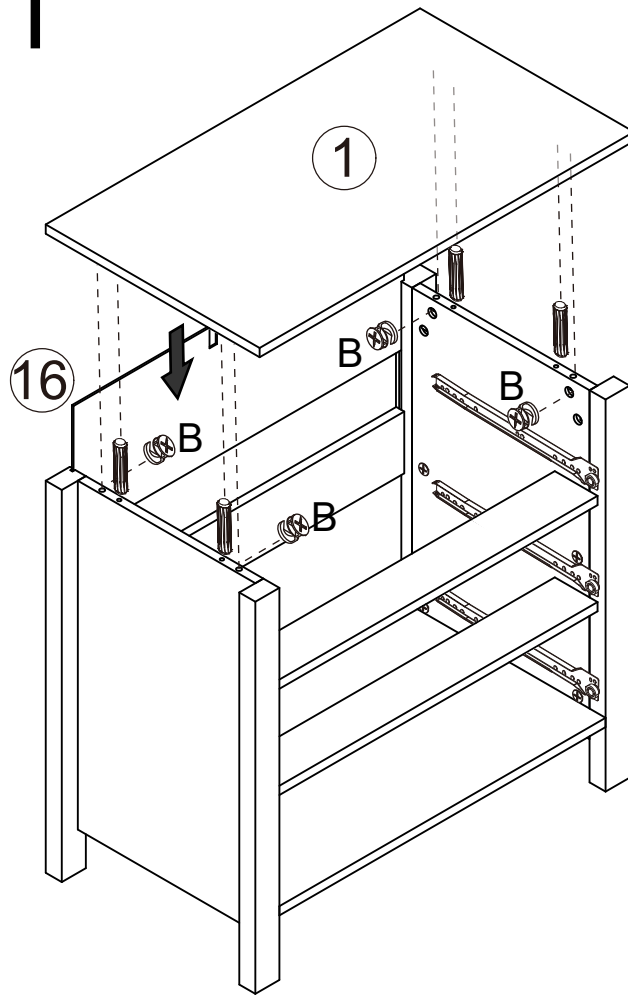

# Step 11



<b>(B) x 4pcs</b>  Ø15x9 mm CAM LOCK	<b>(C) x 4pcs</b>  Ø6x30 mm DOWEL
--	--

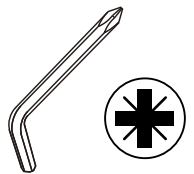
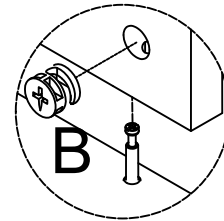

# Step 12

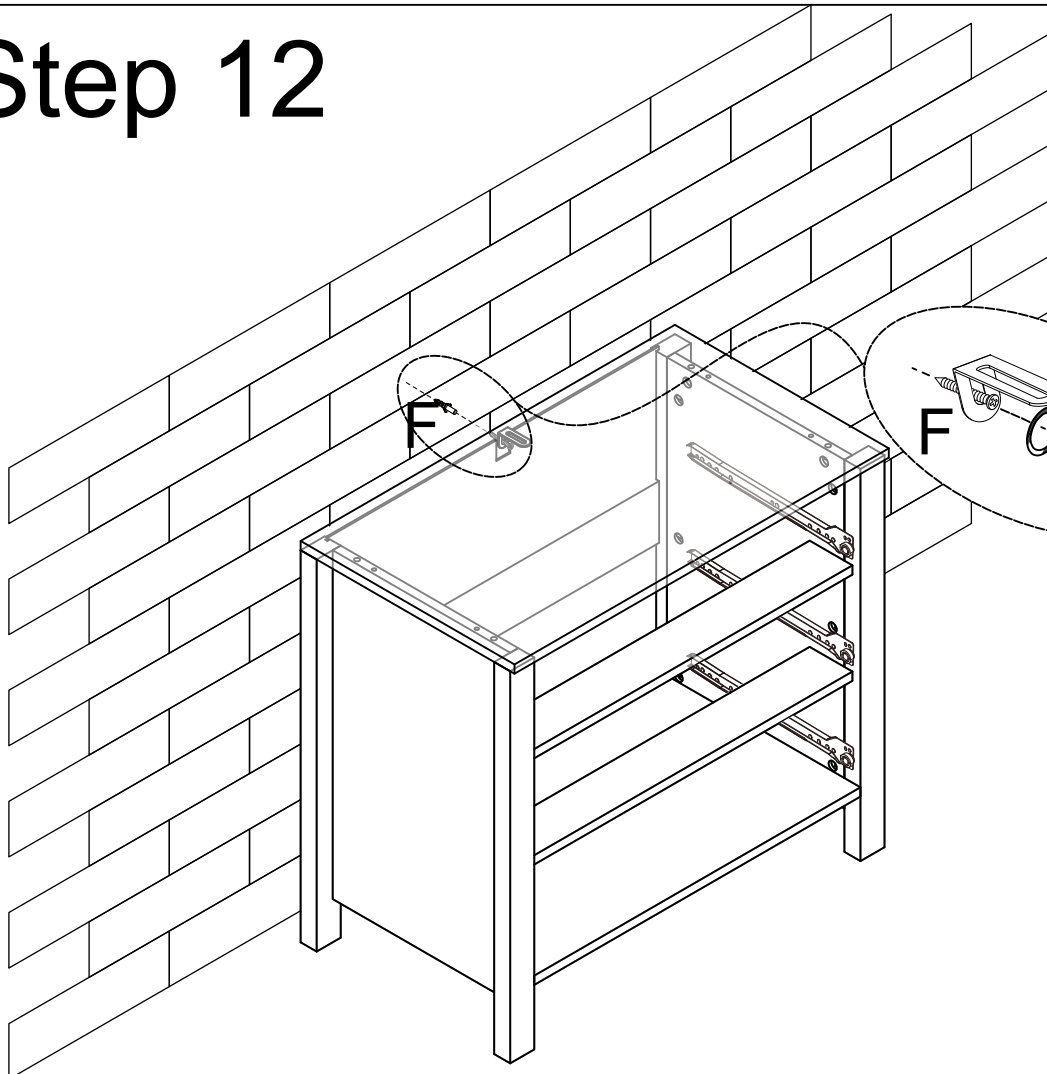

<b>(F) x 1pc</b>  WALL PLUGS
---

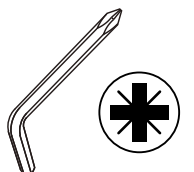

# Step 13

(A) x 12pcs

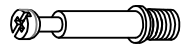

Ø6x35 mm  
CAM STUD

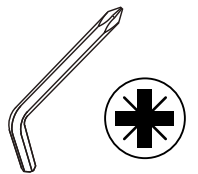
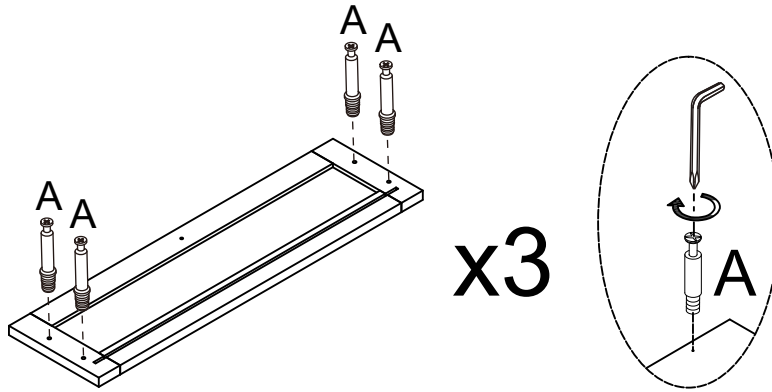

# Step 14

(B) x 12pcs



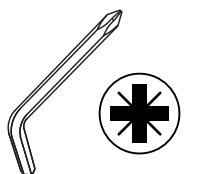
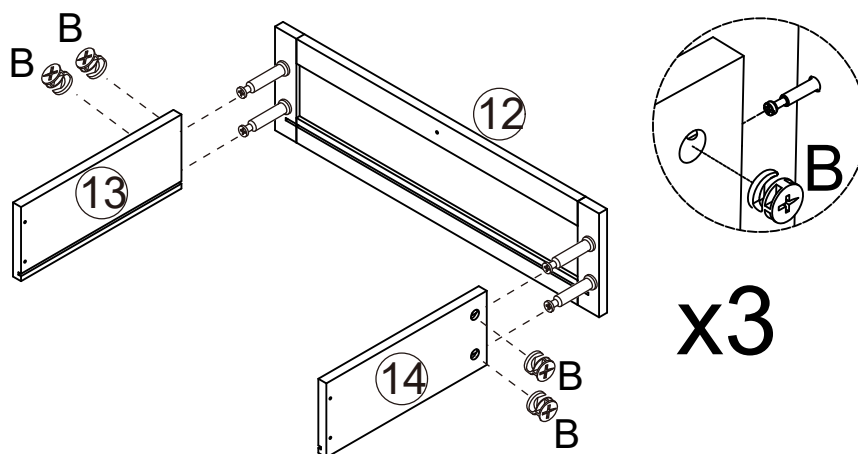

Ø15x9 mm  
CAM LOCK

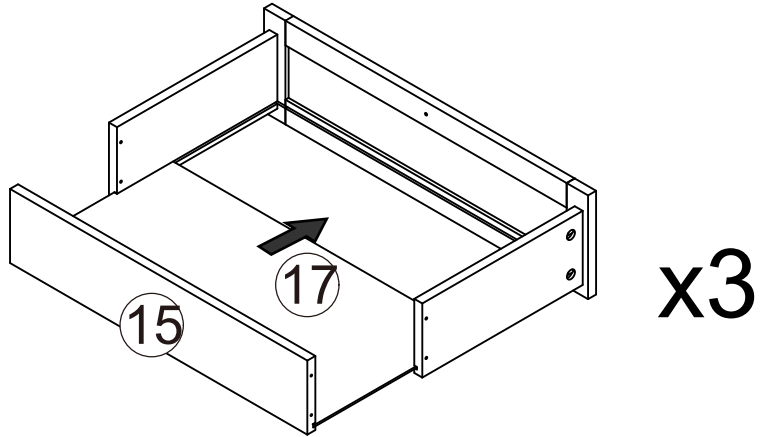

# Step 15



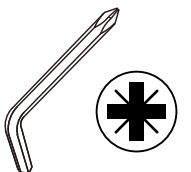
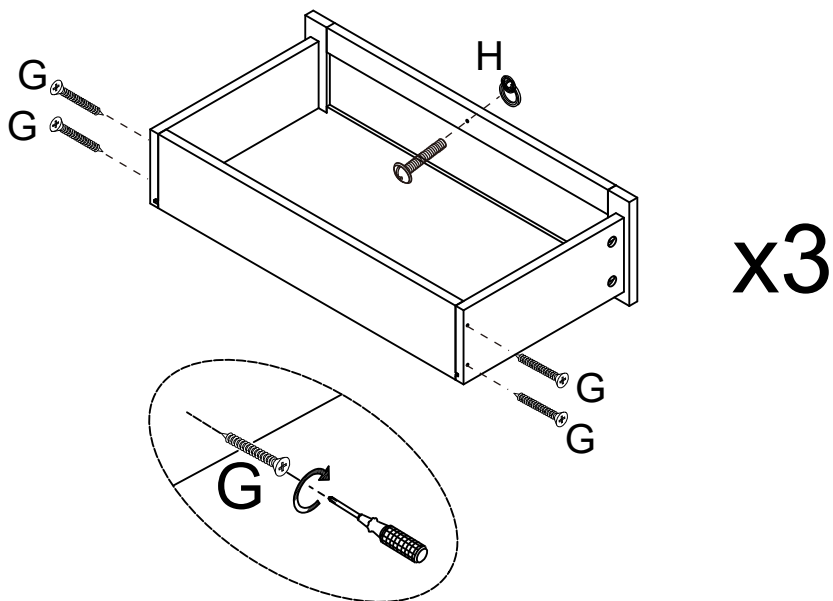

# Step 16

<b>(H)</b> x 3pcs   Ø4x18mm SCREW	<b>(G)</b> x 12pcs  Ø3.5x35mm SCREW
--	--

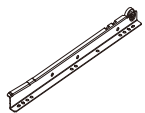
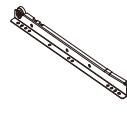

# Step 17

DL x 3pcs 	DR x 3pcs 	D x 12pcs  Ø3.5x12 mm SCREW
--	--	--

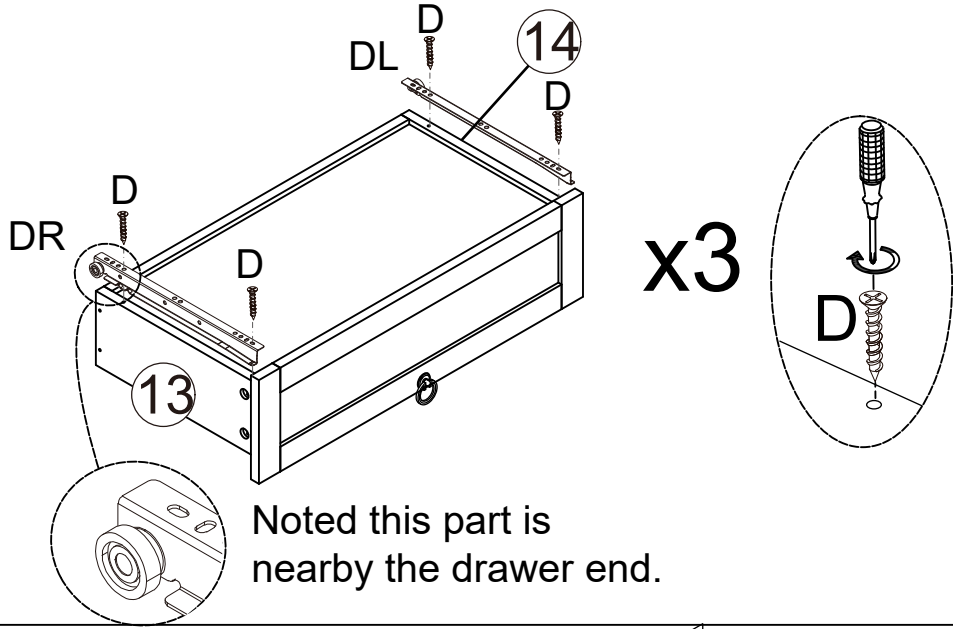
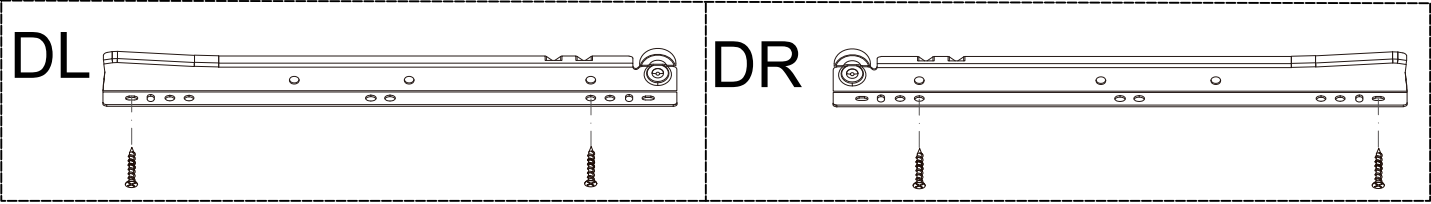

DL D 14 DR D D D 13

x3

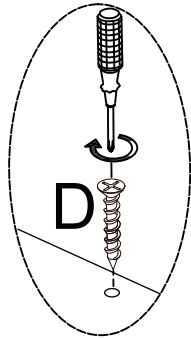

D

Noted this part is nearby the drawer end.

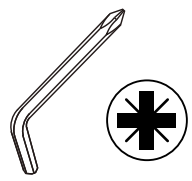

# Step 18

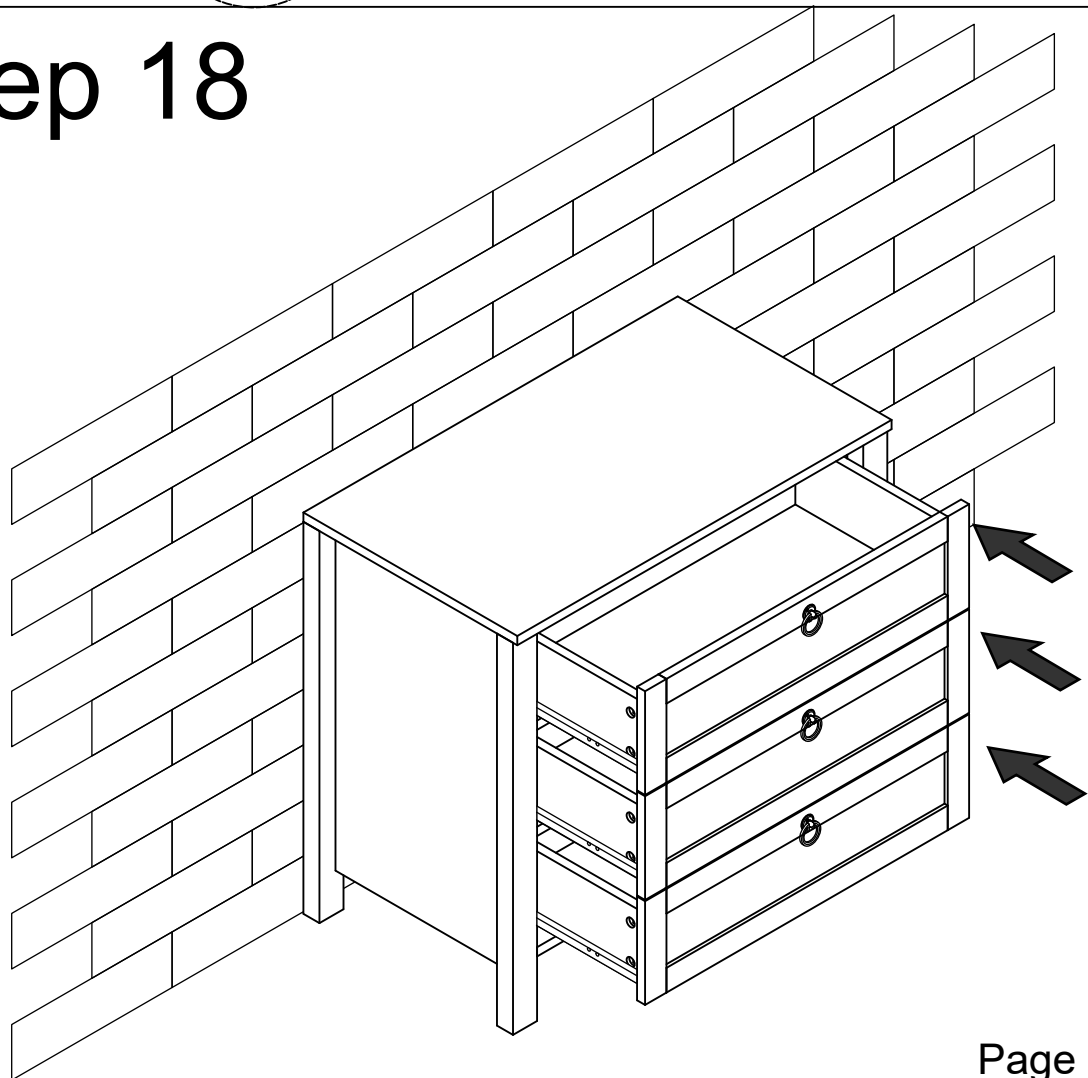

# Step 19

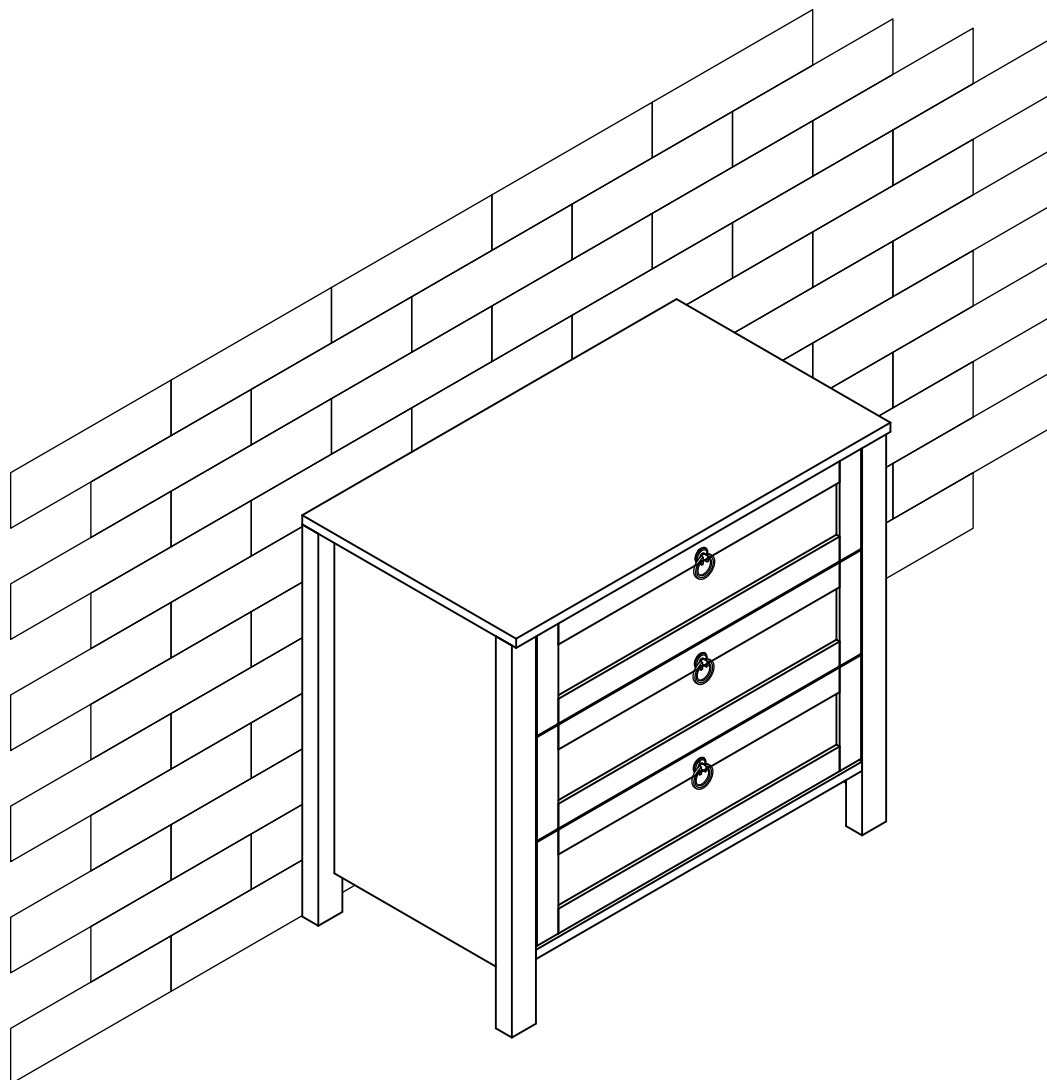

Dear customer, thank you for purchasing Idealhouse products! We are proud to present our customers with high quality products!



If you have any product quality or use problems, please contact our customer service by email, we will ensure your satisfaction.



If you are satisfied with our products, please share your amazing experience with us and other customers! It would be our honor to hear from you!



**Customer Service Team:** [support@garvee.com](mailto:support@garvee.com)