

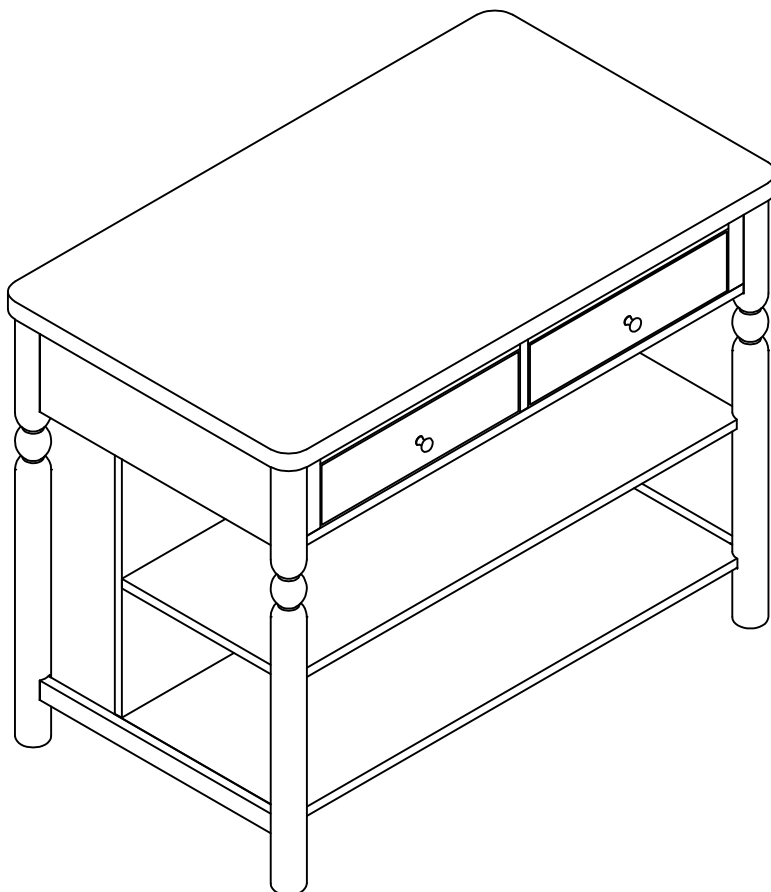

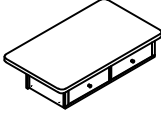

CROSLEY
FURNITURE

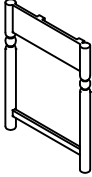

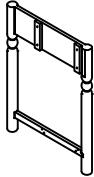
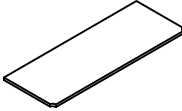

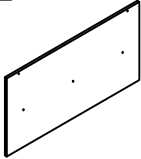

Faux Marble Top Kitchen Island
CF3049

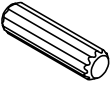

PARTS LIST

<div data-bbox="165 197 209 232" style="border: 1px solid black; padding: 2px;">A</div> 	<div data-bbox="426 197 469 232" style="border: 1px solid black; padding: 2px;">B</div> 	<div data-bbox="686 197 729 232" style="border: 1px solid black; padding: 2px;">C</div> 	<div data-bbox="946 197 989 232" style="border: 1px solid black; padding: 2px;">D</div> 	<div data-bbox="1206 197 1249 232" style="border: 1px solid black; padding: 2px;">E</div> 
<p style="text-align: center;">Top Panel 1 PC</p>	<p style="text-align: center;">Left Panel 1 PC</p>	<p style="text-align: center;">Right Panel 1 PC</p>	<p style="text-align: center;">Shelf 1 PC</p>	<p style="text-align: center;">Bottom Panel 1 PC</p>
<div data-bbox="165 566 209 602" style="border: 1px solid black; padding: 2px;">F</div> 	<div data-bbox="426 566 469 602" style="border: 1px solid black; padding: 2px;">G</div> 			
<p style="text-align: center;">Back Panel 1 PC</p>	<p style="text-align: center;">Support Leg 1 PC</p>			

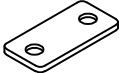
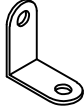
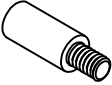
HARDWARE LIST

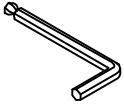
 8*30mm	 7*38mm	 1/4"*32mm		
Wood Dowel 12 PCS (Extra 1)	Tapping Bolt 2 PCS (Extra 1)	Long Bolt 12 PCS (Extra 1)	Spring Washer 12 PCS (Extra 1)	Flat Washer 12 PCS (Extra 1)
			 1/4"*12mm	 7*3.5*15mm
Metal Plate 2 PCS	Shelf Holder 2 PCS (Extra 1)	Shelf Pin 3 PCS (Extra 1)	Short Bolt 4 PCS (Extra 1)	Screw 4 PCS (Extra 1)
 M4 Allen Wrench 1 PC				

ADDITIONAL TOOLS (Not Provided)

Note: It is not recommended to use power tools during assembly.

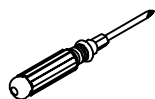

Phillips Head Screwdriver

Note: Wood dowels are intended for alignment. Additional clearance between wood dowel and pre-drilled hole is intentional for ease of assembly.

Step 1. Remove drawers.

Note: To release trigger disconnect levers push one side up and the other down.

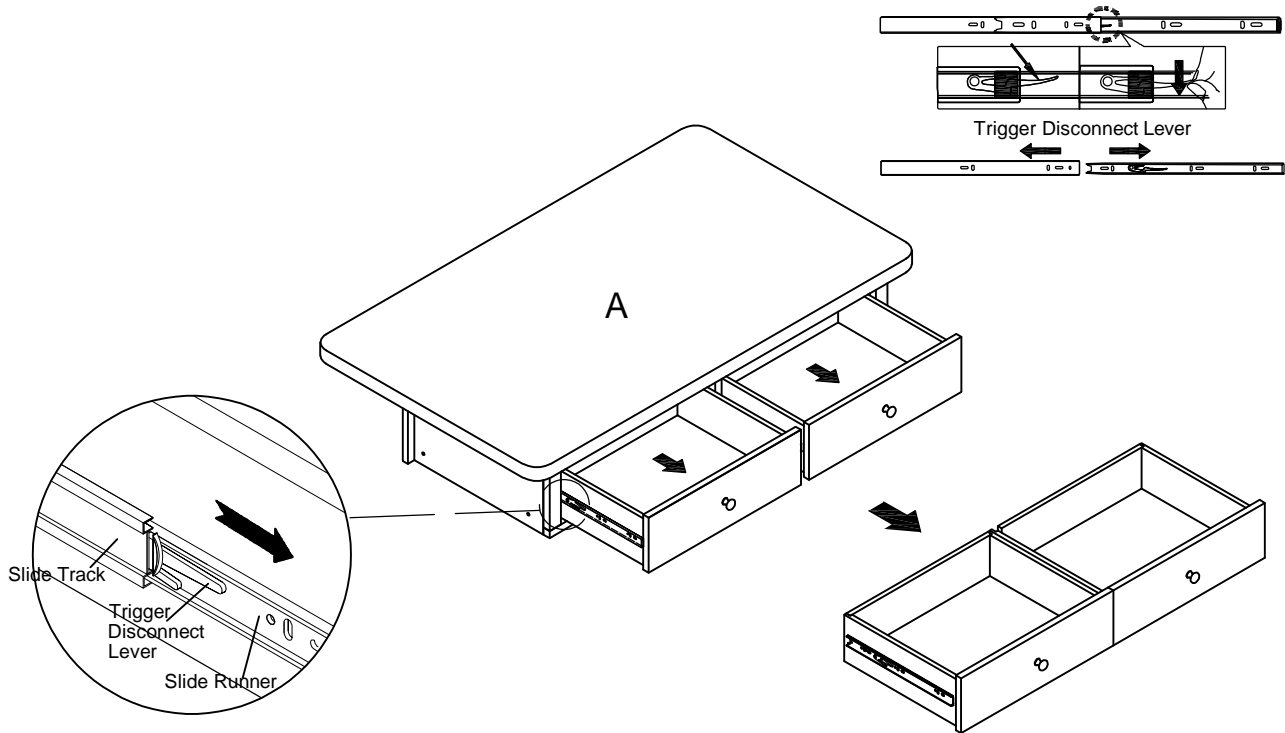



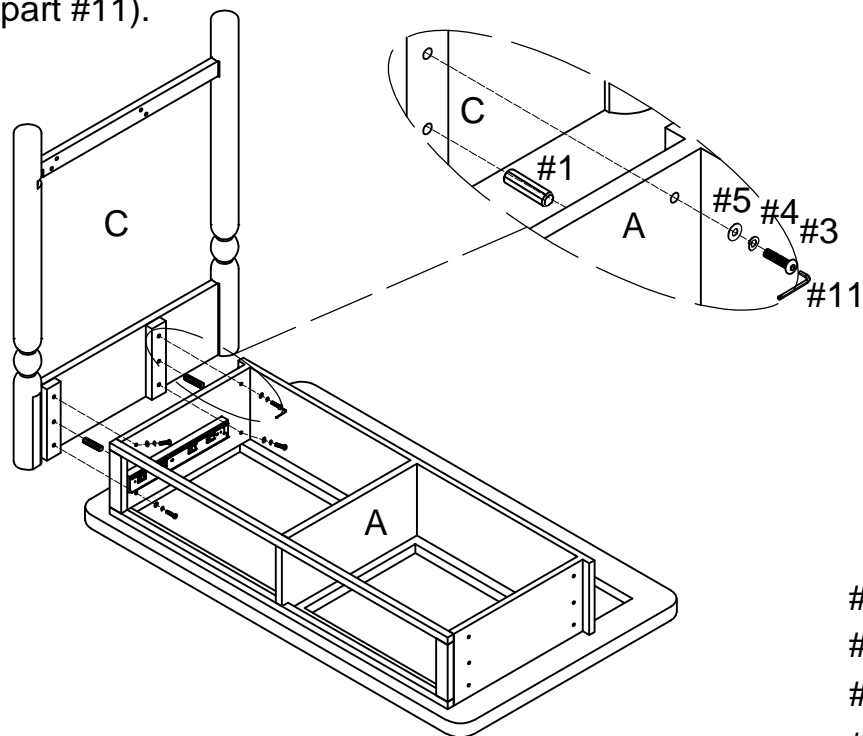

Step 2. Lay top panel (part A) upside down on a soft surface, such as carpet, as shown below. Attach right panel (part C) to top panel (part A) using wood dowels (part #1), long bolts (part #3), spring washers (part #4), flat washers (part #5) and allen wrench (part #11).

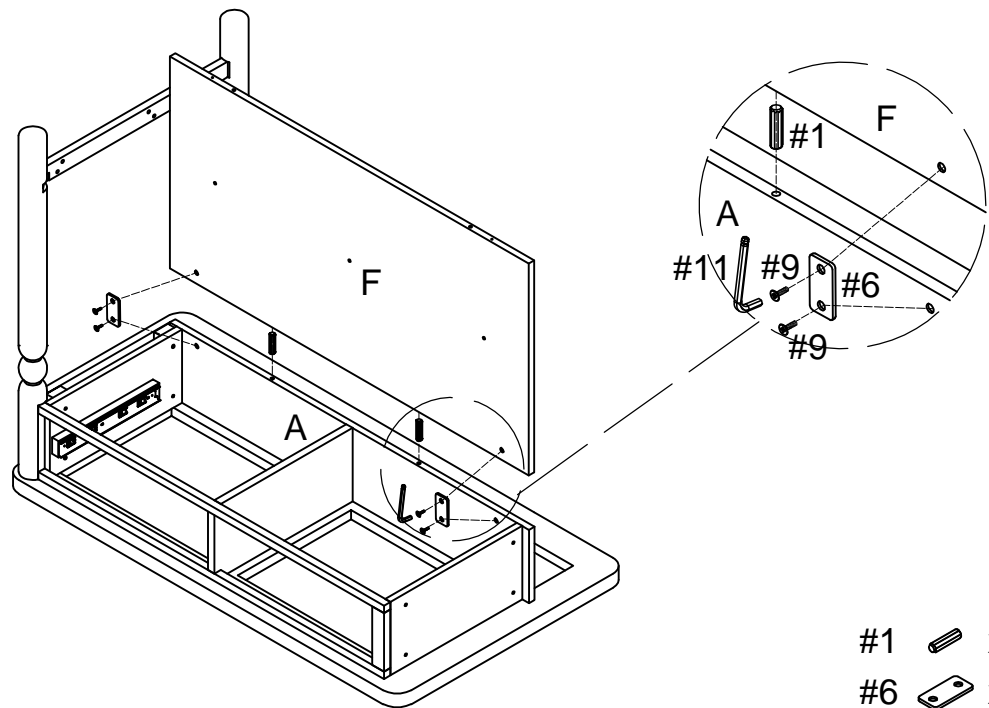

- #1  x 2
- #3  x 4
- #4  x 4
- #5  x 4
- #11  x 1



Step 3. Attach back panel (part F) to top panel (part A) using wood dowels (part #1), metal plates (part #6), short bolts (part #9) and allen wrench (part #11).

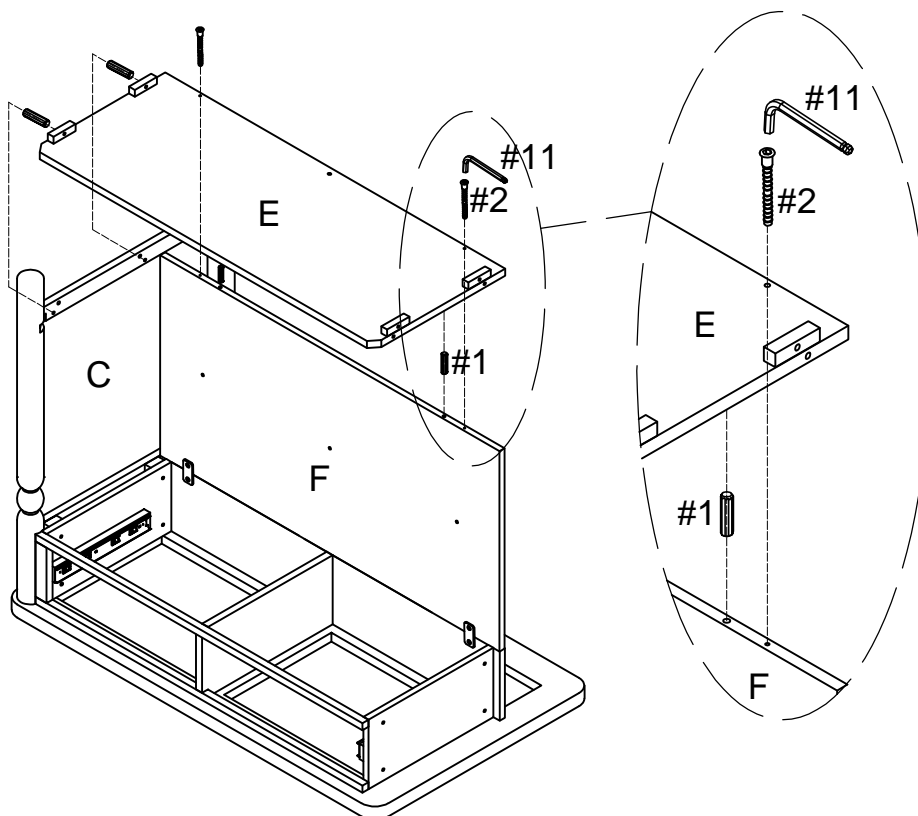

- #1  x 2
- #6  x 2
- #9  x 4
- #11  x 1

Step 4. Attach bottom panel (part E) to panel (parts C & F) using wood dowels (part #1), tapping bolts (part #2) and allen wrench (part #11).



- #1  x 4
- #2  x 2
- #11  x 1

Step 5. Secure bottom panel (part E) to right panel (part C) using long bolts (part #3), spring washers (part #4), flat washers (part #5) and allen wrench (part #11).

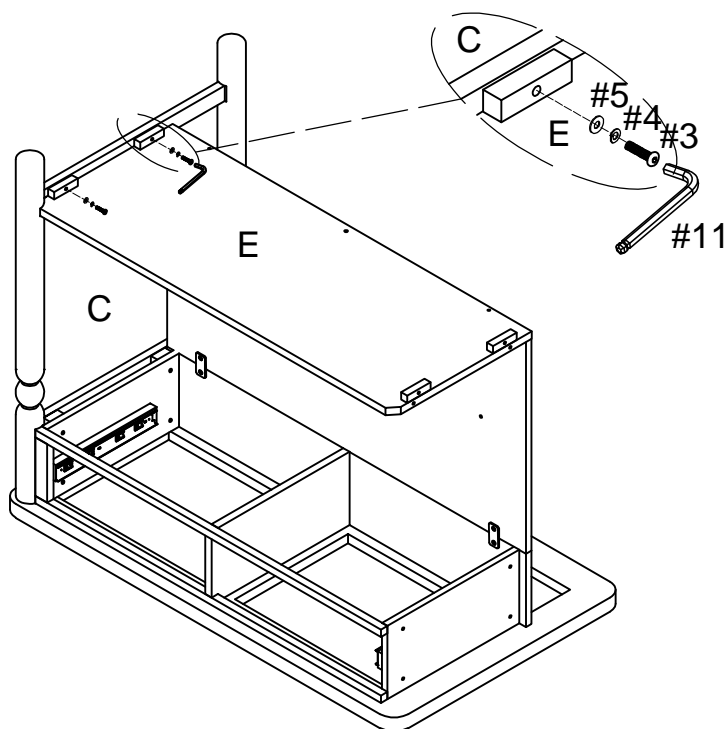

- #3  x 2
- #4  x 2
- #5  x 2
- #11  x 1

Step 6. Attach left panel (part B) to assembled unit (parts A & E) using wood dowels (part #1), long bolts (part #3), spring washers (part #4), flat washers (part #5) and allen wrench (part #11).

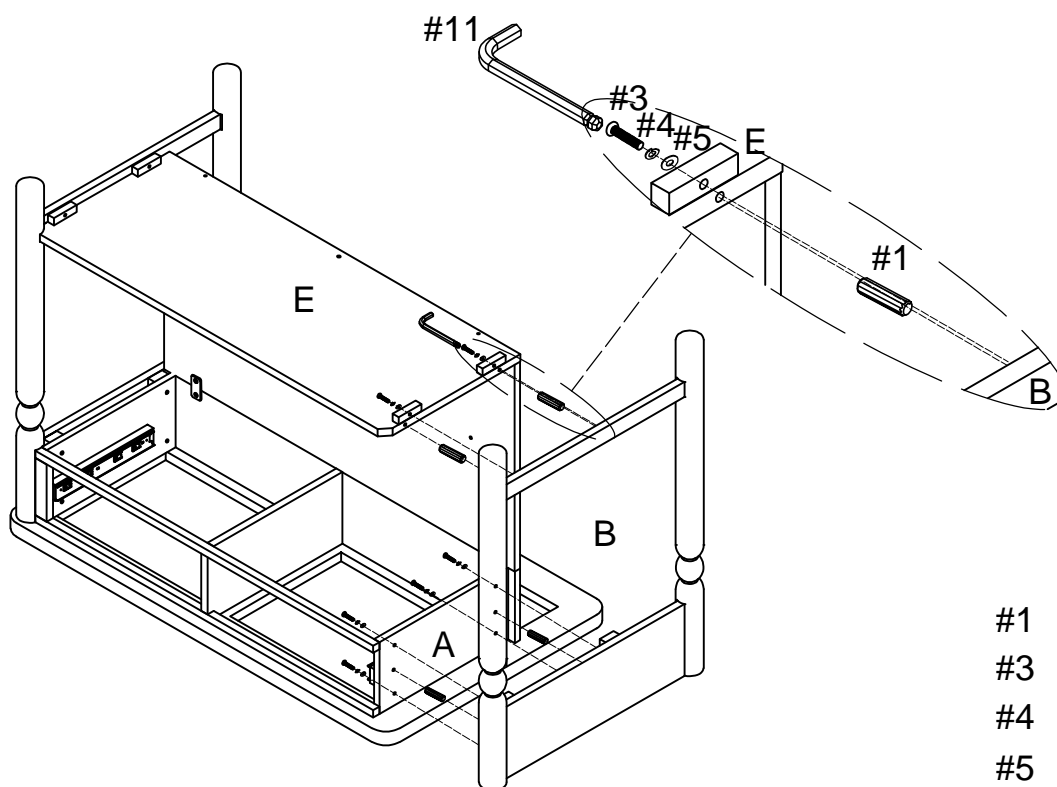

- #1  x 4
- #3  x 6
- #4  x 6
- #5  x 6
- #11  x 1

Step 7. Attach support leg (part G) to bottom panel (part E).

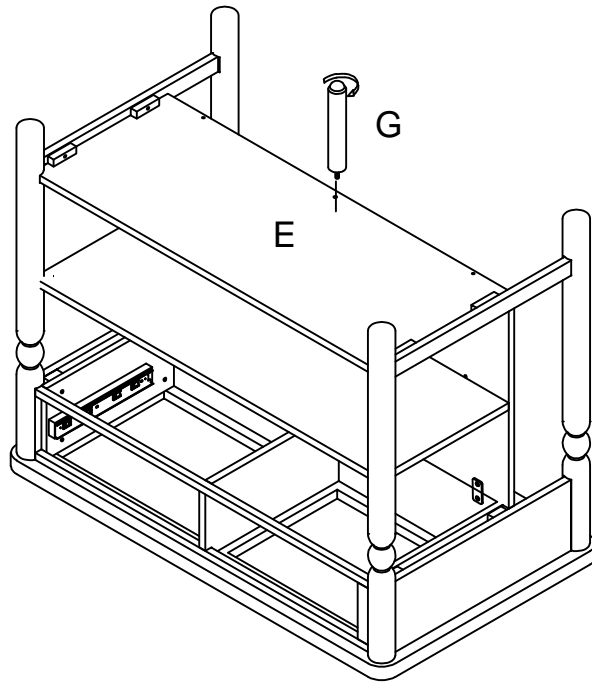

Step 8. Carefully turn unit upright. Slide drawers into place.

Note: To release trigger disconnect levers push one side up and the other down.

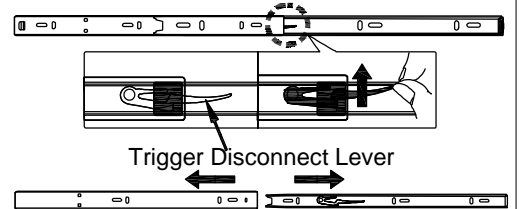
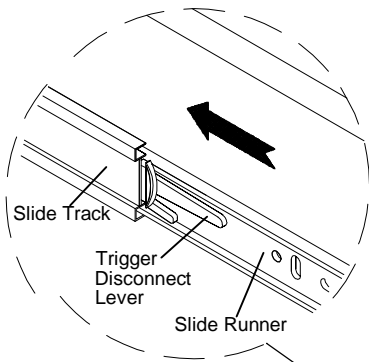

Move the sliders to the front end of rail before sliding the drawer into place.

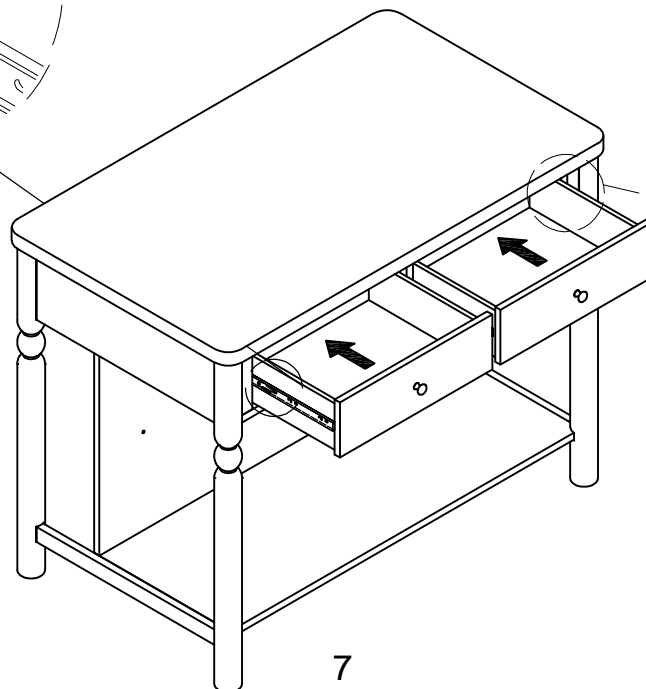

Step 9. Insert shelf pins (part #8) into desired position and attach shelf (part D) to assembled unit (parts B, C & F) using shelf holders (part #7), screws (part #10) and phillips head screwdriver.

Note: It is important to adjust levelers once fully assembled and upright. Extend adjustable leveler until it's firmly in contact with the floor. If relocating, adjust leveler as needed until it's firmly in contact with the floor in new location.

