















ASSEMBLY INSTRUCTION

A	 Headboard	1 pc
B	 Footboard	1 pc
C	 Side Rail	2 pcs
D	 Leg	4 pcs
E	 Center Rail	2 pcs
F	 Support Leg	6 pcs
G	 Slat	42 pcs
H	 Middle Holder	28 pcs
I	 End Holder	28 pcs
J	 JCBC M6 X 40	6 pcs
K	 M4 x 65mm	1 pc
L	 CSK M4 x 25mm	4 pcs
M	 CSK M4 x 32mm	4 pcs
N	 Stiffener Slat (4 Holes)	1 pc
O	 Adjuster	6 pcs

Step 1: Tighten the legs (D) to both headboard (A) and footboard (B) as shown.

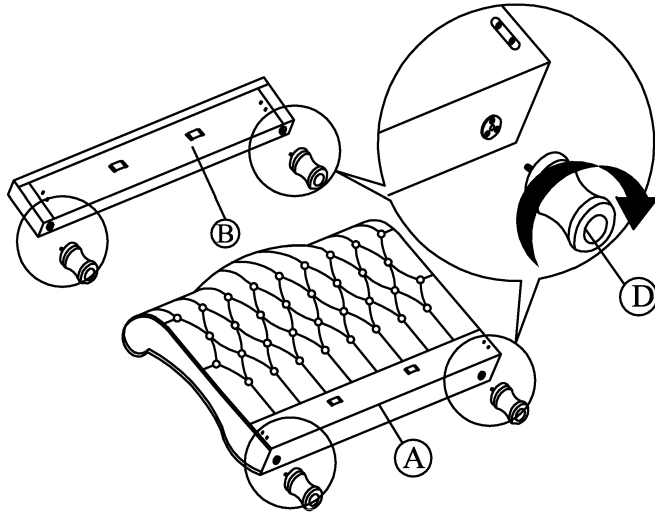

Step 2: Dismantle the JCBC screws and flat washers from headboard (A) and footboard (B) as shown.

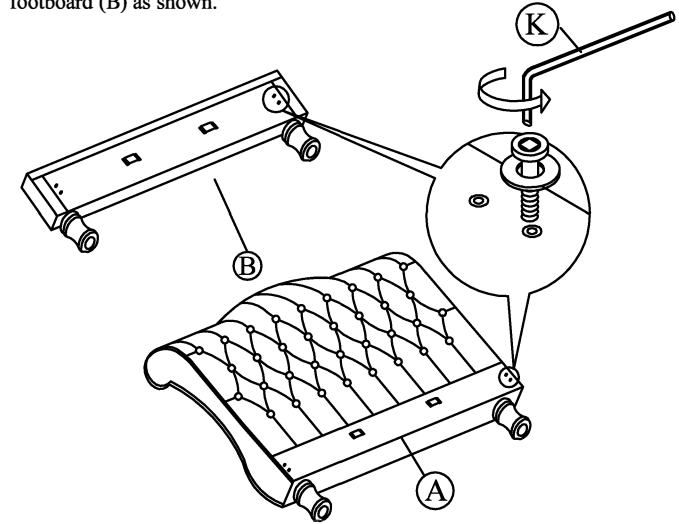

Step 3: Tighten the screws and flat washers dismantled from step 2 to the headboard (A) and footboard (B).

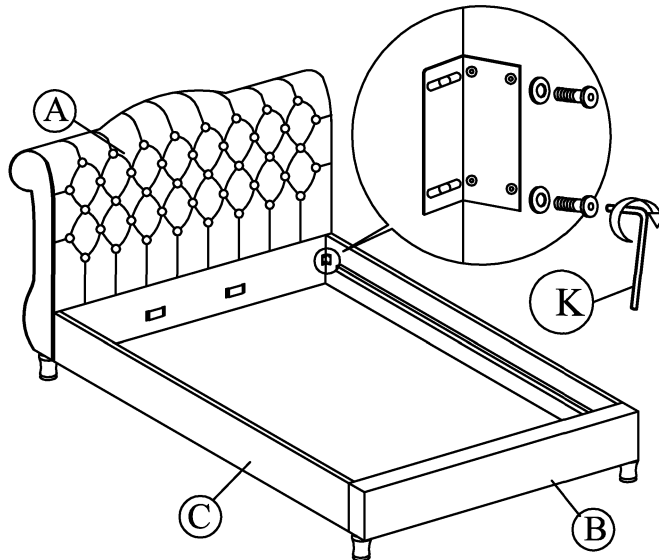

Step 4: Attach the support legs (F) to the center rail (E) of the bed as shown.

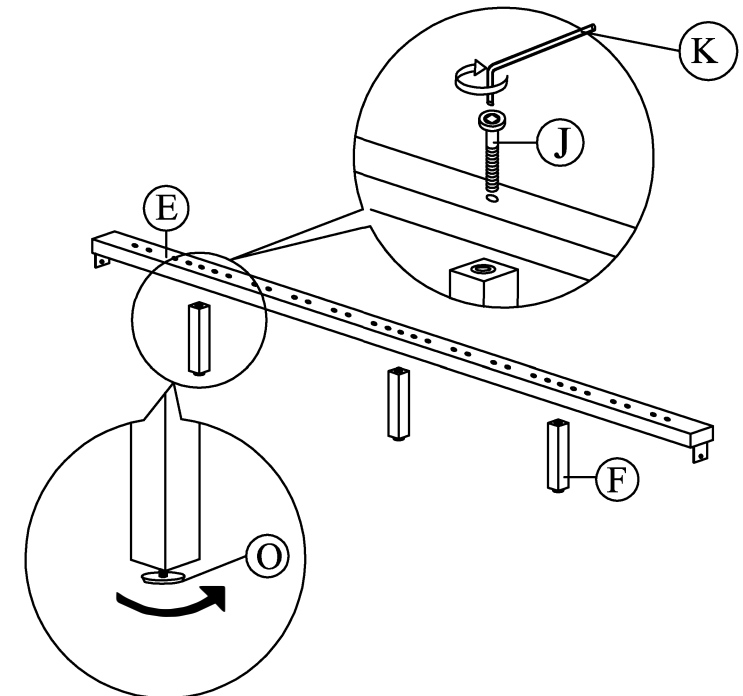

Step 5: Slide the center rail (E) to the headboard (A) and footboard (B). Tighten screws (L) using screw driver (not included) to the headboard (A) and footboard (B).

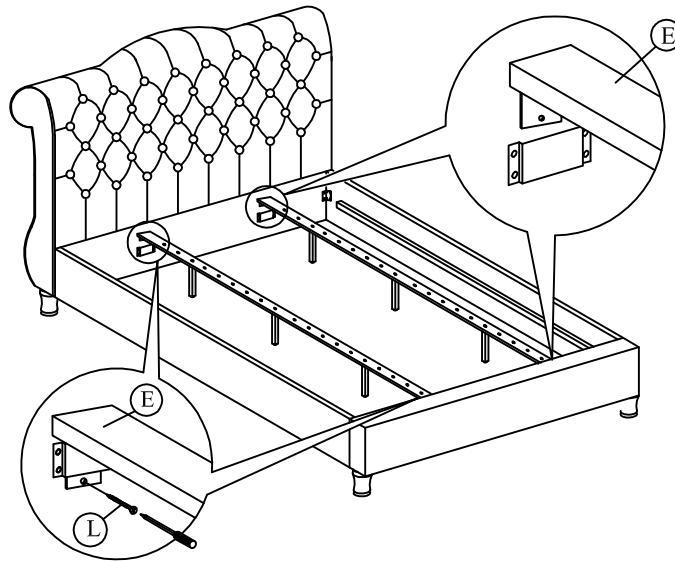

Step 6: Affix the Stiffener Slat (N) to the side rail support wood and the center rail (E), follow by a assembly of the slat holders with LVL slats as shown.

