

Notice:

1. follow the installation instructions. please confirm all accessories are preset before installation.
2. do not fully tighten screws during initial assembly. gently adjust the board to make them level. only tighten after all pieces are correctly assembled.
3. if you encounter any problems during installation, refer to two solutions: follow the installation video tutorial on the amazon product page or contact our customer service.

Beachten:

1. befolgen sie die installationsanweisungen. bitte bestätigen sie vor der installation, dass alle zubehörteile voreingestellt sind.
2. ziehen sie die schrauben bei der erstmontage nicht vollständig an. stellen sie das board vorsichtig so ein, dass es eben ist. erst festziehen, wenn alle teile richtig zusammengebaut sind.
3. wenn während der installation probleme auftreten, finden sie zwei lösungen: befolgen sie das installationsvideo-tutorial auf der amazon-produktseite oder wenden sie sich an unseren kundendienst.

Remarques:







1. suivez les instructions d' installation. assurez-vous que toutes les pièces jointes sont prépositionnées avant l' installation svp.
2. ne serrez pas complètement les vis lors de l' installation initiale. ajustez doucement les plaques pour les niveler. serrez seulement après que tous les composants ont été assemblés correctement.
3. si vous rencontrez des problèmes lors de l' installation, référez-vous à deux solutions: suivez le didacticiel vidéo d' installation sur la page de produit amazon ou contactez notre service à la clientèle

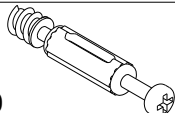
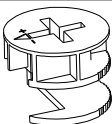
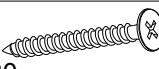
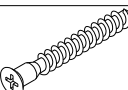

Nota:

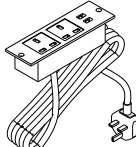
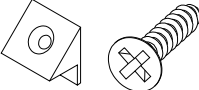
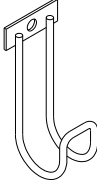
1. seguire le istruzioni di installazione. assicurarsi che tutti gli accessori siano prerogolati prima dell' installazione.
2. non avvitare completamente le viti durante l' assemblaggio iniziale. regolare delicatamente le assi per livellarle. avvitare solo quando tutti i pezzi sono assemblati correttamente.
3. se incontri qualsiasi problema durante l' installazione, fai riferimento a queste due soluzioni: segui il video tutorial d' installazione sulla pagina amazon del prodotto o contatta il nostro servizio clienti.

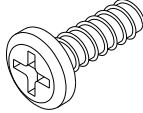
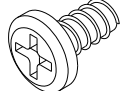

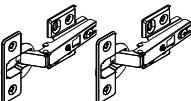
Aviso:

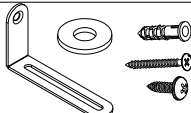
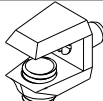
1. siga las instrucciones de instalación. revise que todos los accesorios estén en condiciones antes de la instalación.
2. no apriete los tornillos por completo durante la instalación inicial. ajuste suavemente el tablero para nivelar. apriete por completo una vez que todas las piezas estén colocadas correctamente.
3. si encuentra algún problema durante la instalación: siga el video tutorial de instalación en la página del producto en amazon, o póngase en contacto con nuestro servicio de atención al cliente.

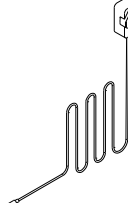
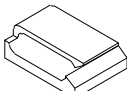
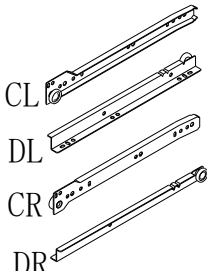
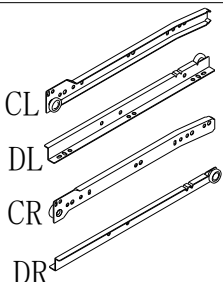
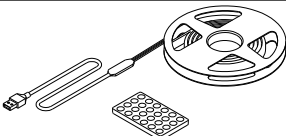
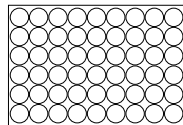
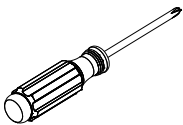

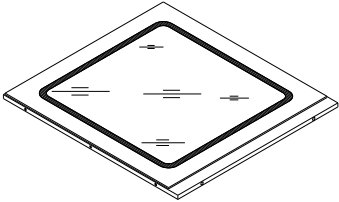
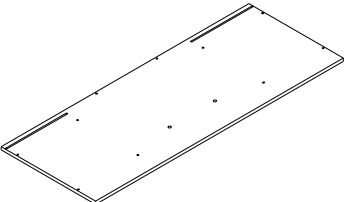
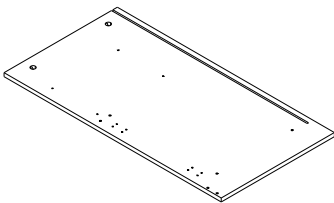
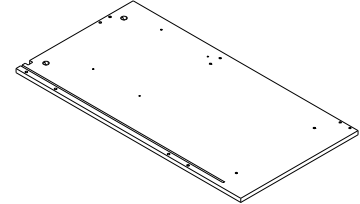
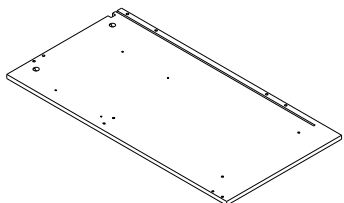
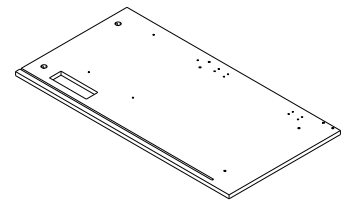
Item no. Nr. N° d'article Articolo No. N° de Artículo	Reference Image Referenzbild Image de référence Immagine di riferimento Imagen de referencia	Qty. Menge Qté. Qtà Cant.
A	 M6*40	X98
B	 Ø15*10	X98
C	 M3.5*30	X22
D	 M5*48	X12
E	 M3.5*12	X82
H		X1
I	 M3.5*12	X12
J		X2
K		X7
L	 M6*20	X2
N	 M6*10	X2
S	 M4*16	X7
M		X3

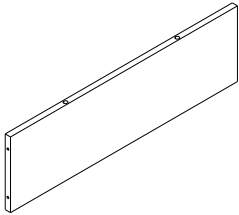
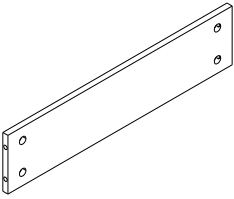
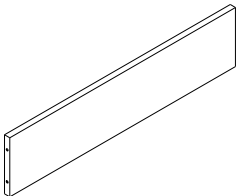

Item no. Nr. N° d'article Articolo No. N° de Artículo	Reference Image Referenzbild Image de référence Immagine di riferimento Imagen de referencia	Qty. Menge Qté. Qtà Cant.
O		X2
Q		16
U		X4
V		X1
W		X1
10"		X2
12"		X3
T		X1
		X2
	 TOOL Werkzeug Outil Strumento Herramienta	

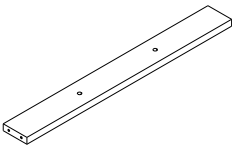
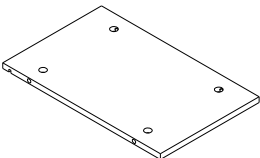
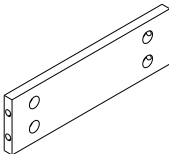
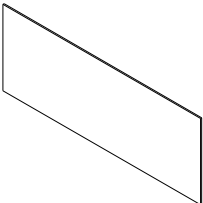
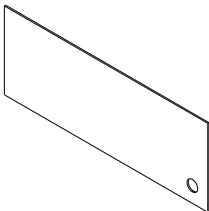
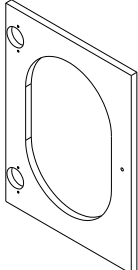

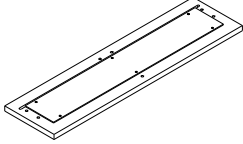
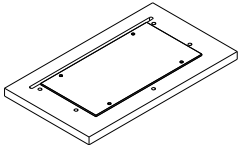
Item no. Nr. N° d'article Articolo No. N° de Artículo	Reference Image Referenzbild Image de référence Immagine di riferimento Imagen de referencia	Qty. Menge Qté. Qtà Cant.
①		X1
②		X1
③		X1
④		X1
⑤		X1
⑥		X1

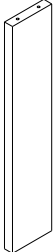
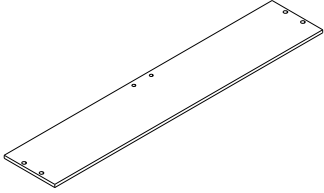
Item no. Nr. N° d'article Articolo No. N° de Artículo	Reference Image Referenzbild Image de référence Immagine di riferimento Imagen de referencia	Qty. Menge Qté. Qtà Cant.
⑦		X2
⑧		X1
⑨		X1
⑩		X1
⑪		X1
⑫		X1

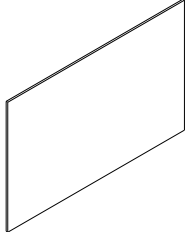
Item no. Nr. N° d'article Articolo No. N° de Artículo	Reference Image Referenzbild Image de référence Immagine di riferimento Imagen de referencia	Qty. Menge Qté. Qtà Cant.
13		X1
14		X2
15		X4
16		X1
17		X1
18		X2

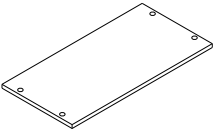
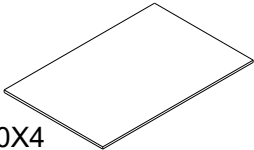
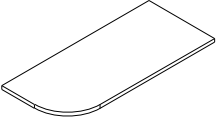
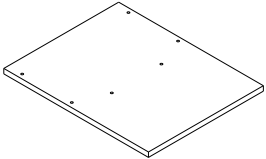
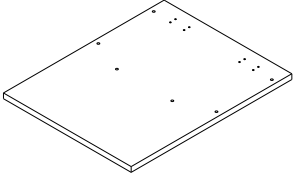
Item no. Nr. N° d'article Articolo No. N° de Artículo	Reference Image Referenzbild Image de référence Immagine di riferimento Imagen de referencia	Qty. Menge Qté. Qtà Cant.
19		X1
20		X4
21		X1
22		X1
23		X1
24		X1

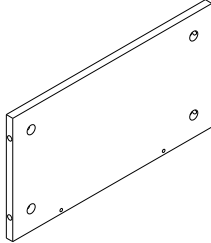
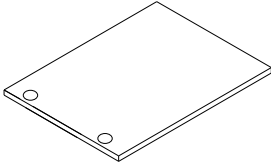
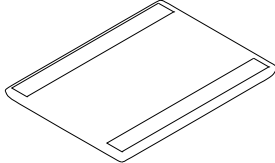
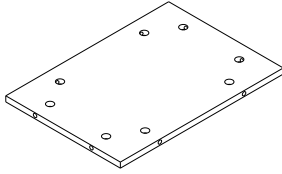
Item no. Nr. N° d'article Articolo No. N° de Artículo	Reference Image Referenzbild Image de référence Immagine di riferimento Imagen de referencia	Qty. Menge Qté. Qtà Cant.
25		X1
26	300X110X12 	X2
27	300X110X12 	X2
28		X4
29	305X200X4 	X2
30		X4
31		X1
32		X1

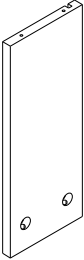
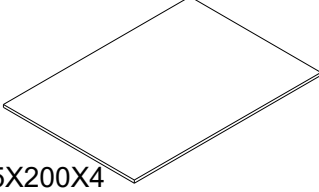
Item no. Nr. N° d'article Articolo No. N° de Artículo	Reference Image Referenzbild Image de référence Immagine di riferimento Imagen de referencia	Qty. Menge Qté. Qtà Cant.
33		X2
34		X1
35		X1
36		X1
37	280X110X12 	X2
38	280X110X12 	X2
39	285X200X4 	X2

ASSEMBLY INSTRUCTION

STEP1

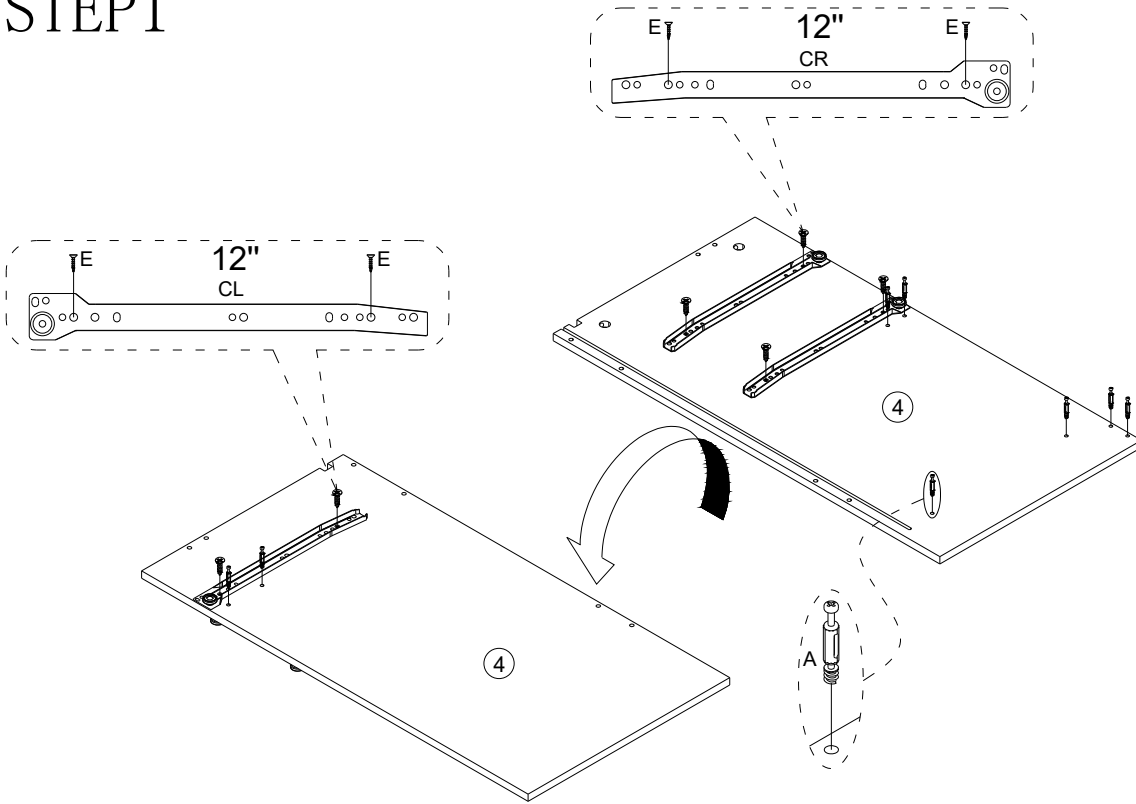

A 8PCS

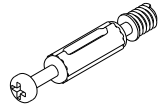

E 6PCS

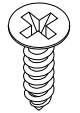

12" 1PC

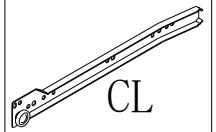

12" 2PCS

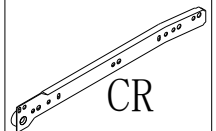

STEP2

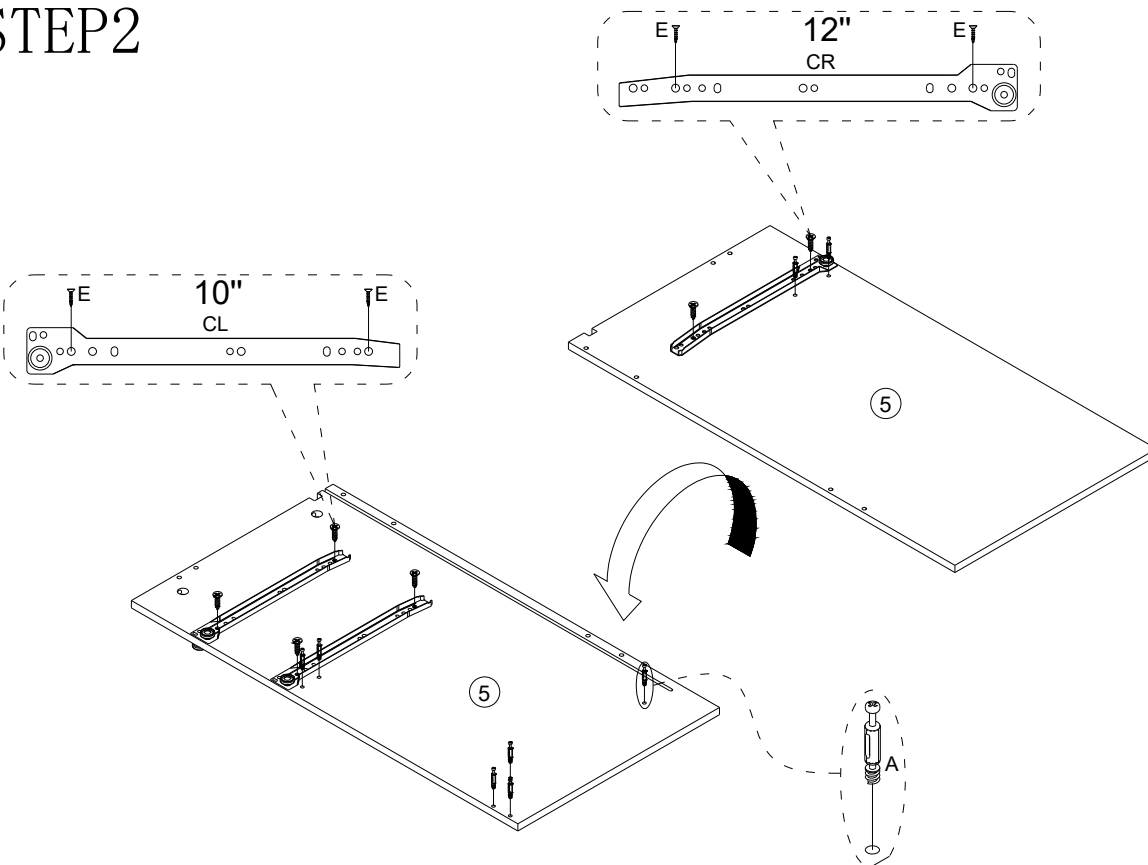

A 8PCS

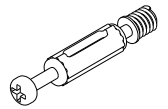

E 6PCS

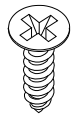

10" 2PCS

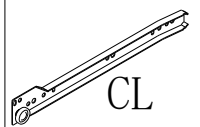

12" 1PC

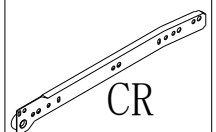

ASSEMBLY INSTRUCTION

STEP3

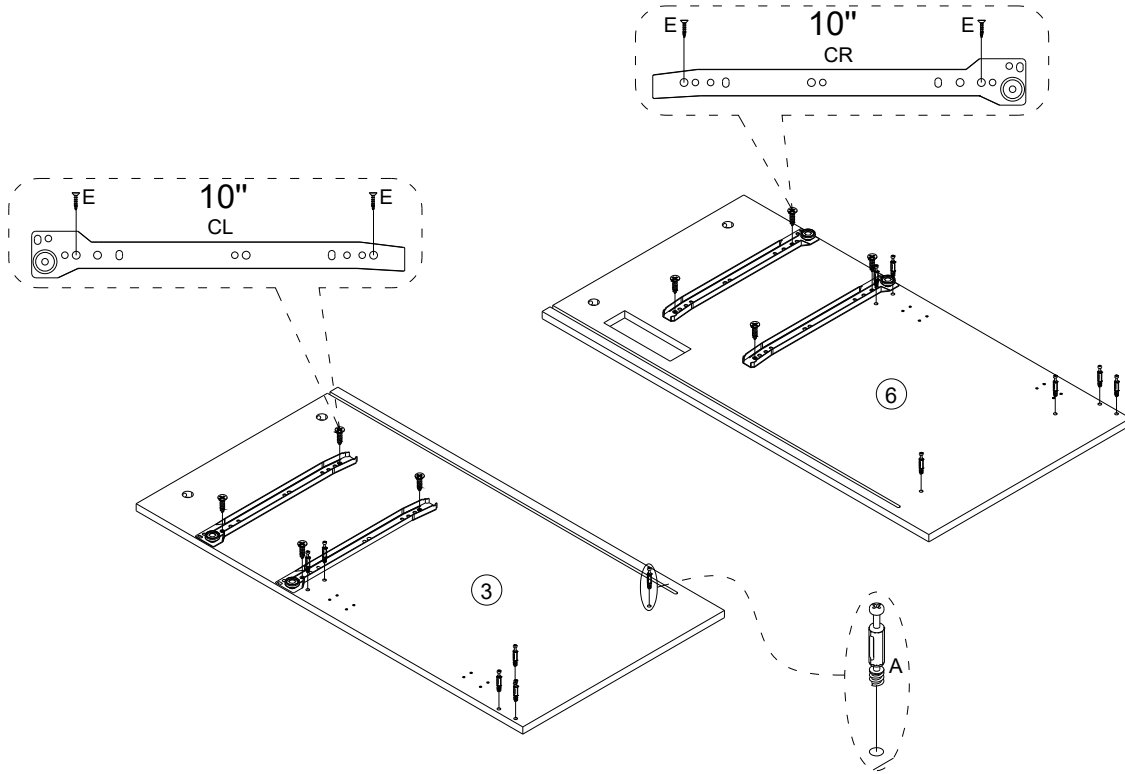

A 12PCS

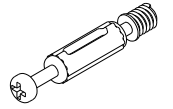

E 8PCS

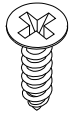

10" 2PCS

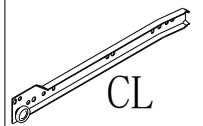

10" 2PCS

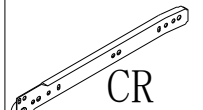

STEP4

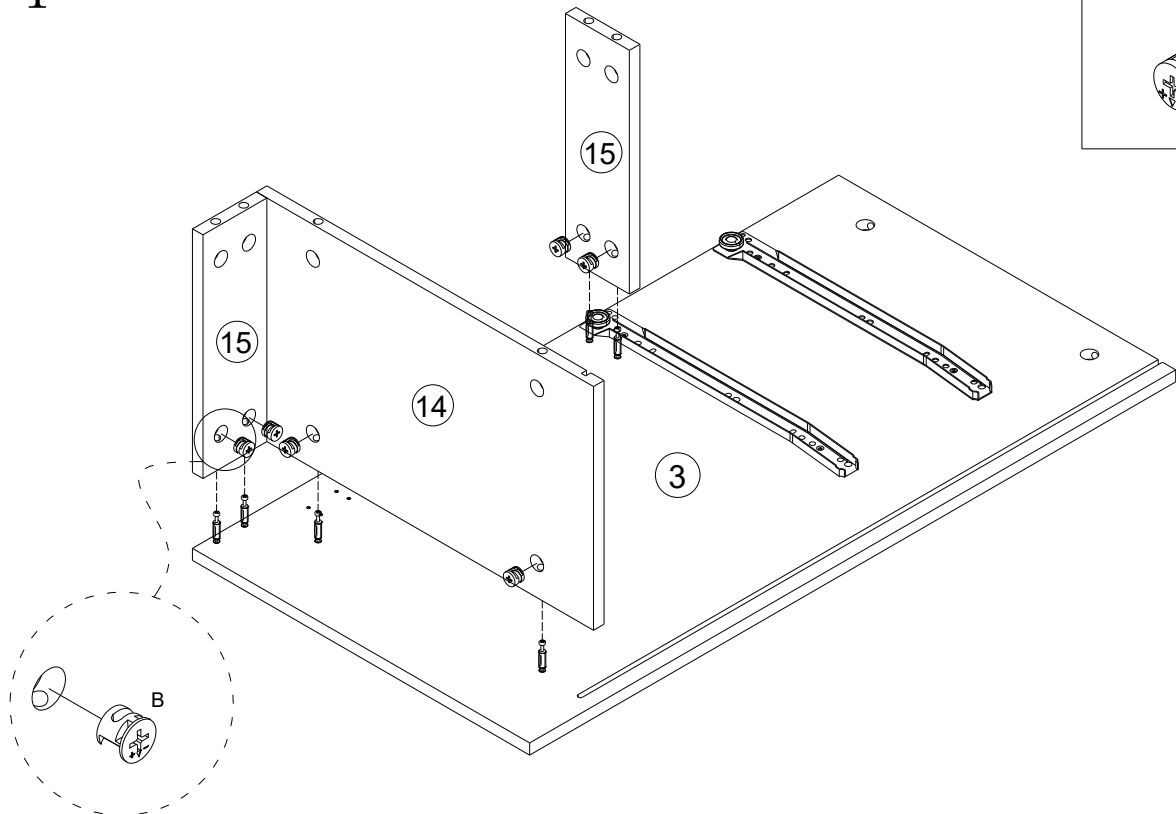

B 6PCS



ASSEMBLY INSTRUCTION

STEP5

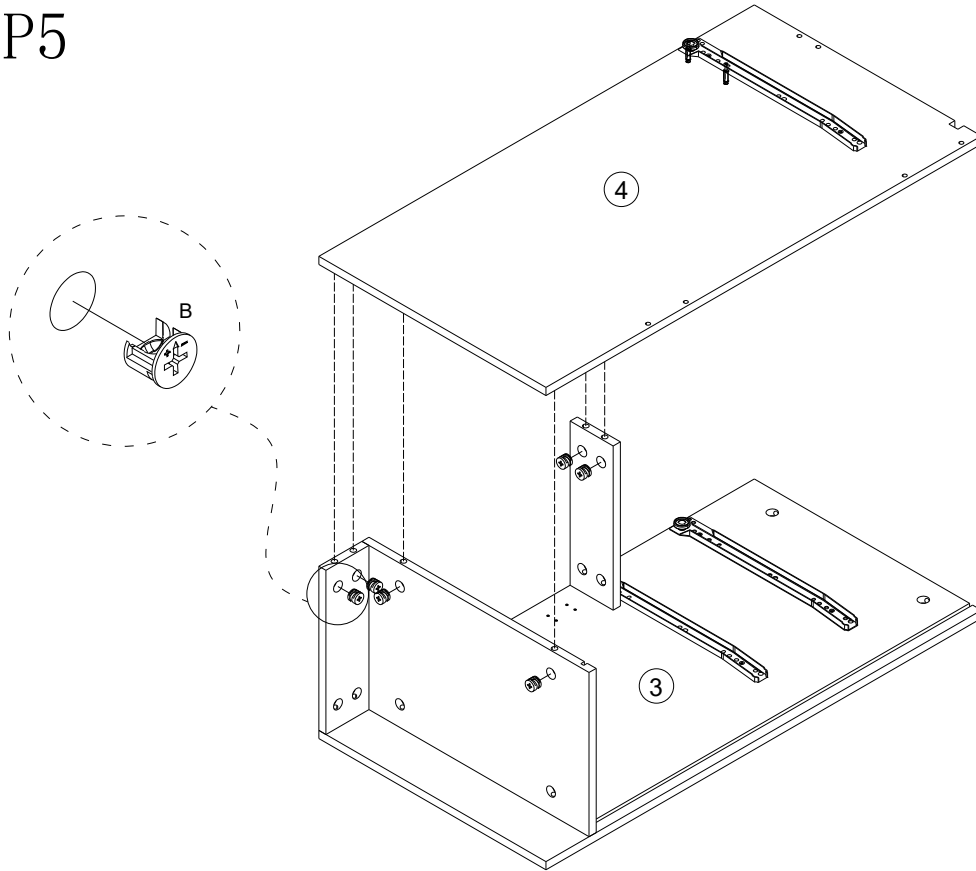

B 6PCS



STEP6

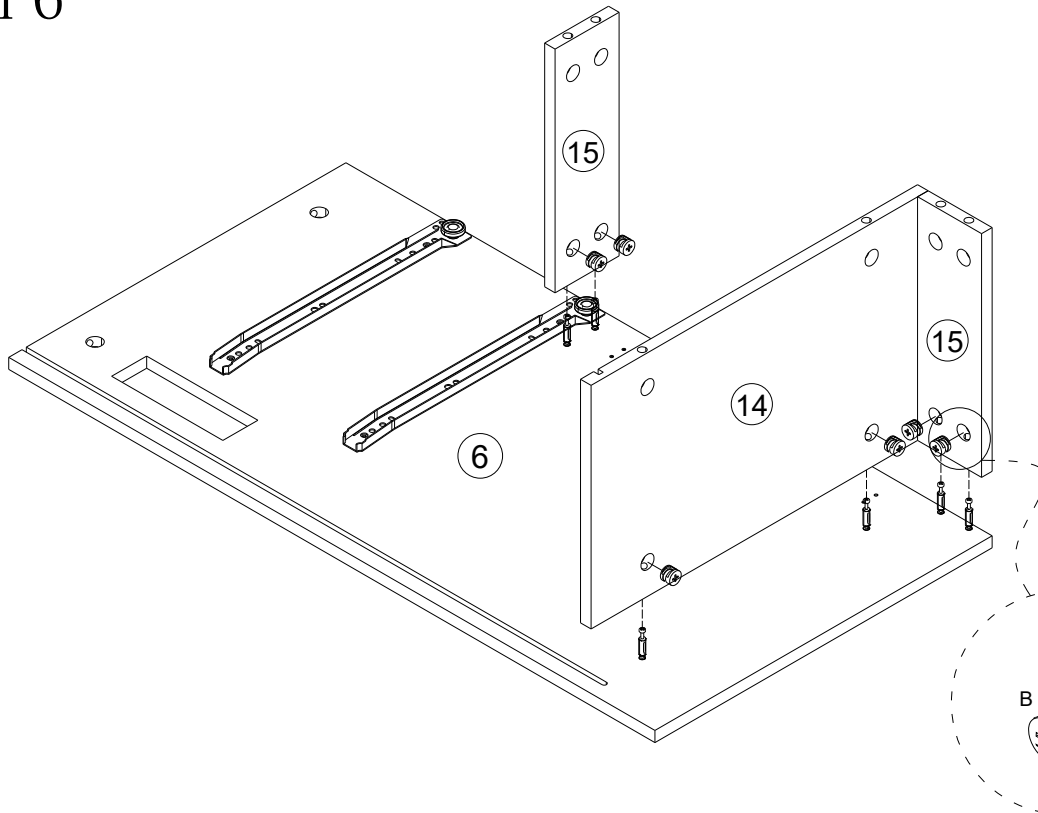

B 6PCS



ASSEMBLY INSTRUCTION

STEP 7

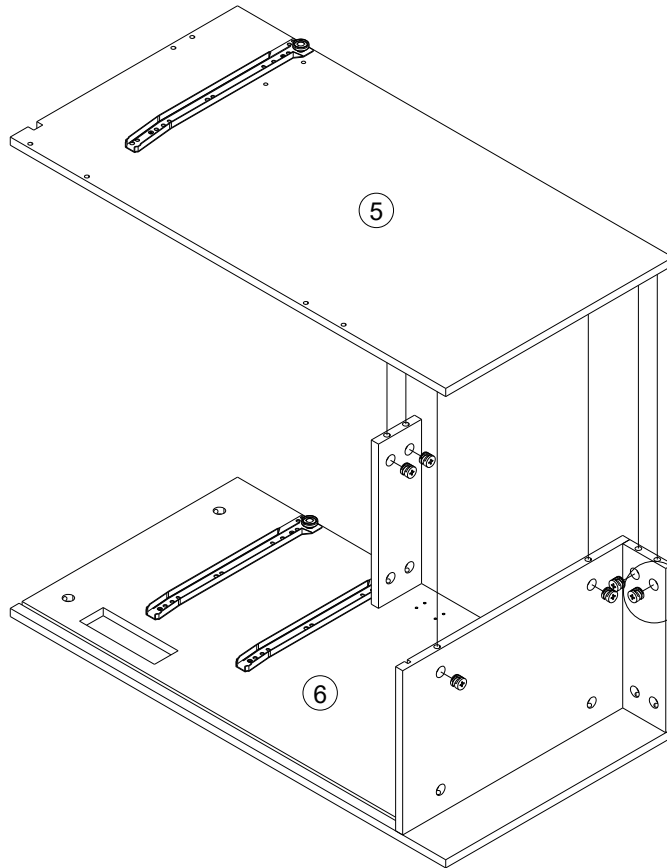

B 6PCS

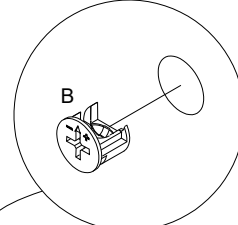

STEP 8

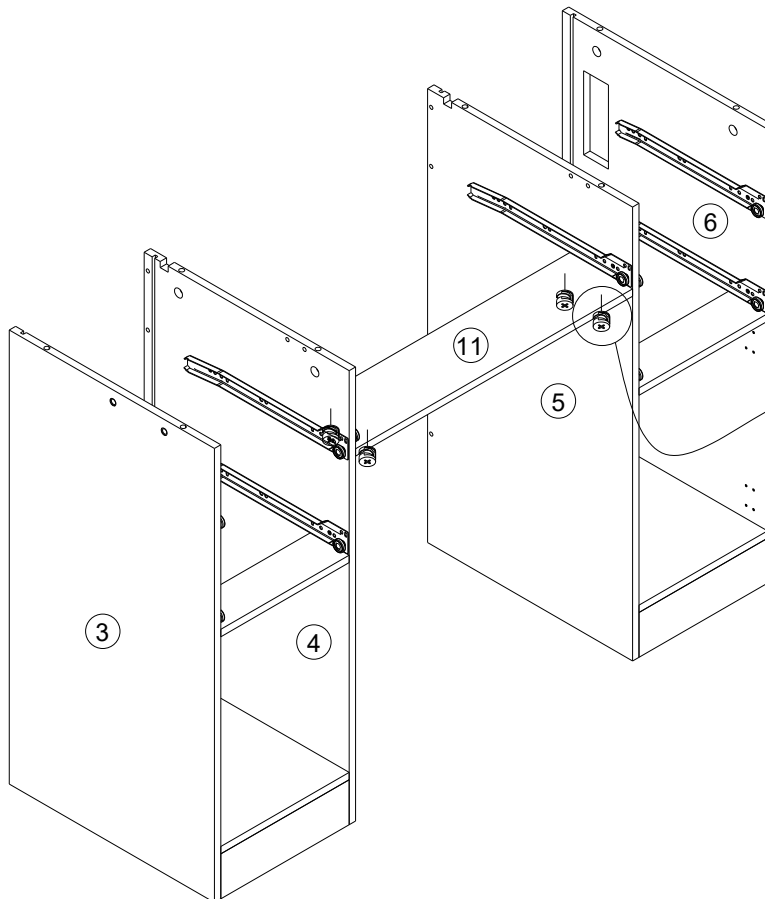

B 4PCS

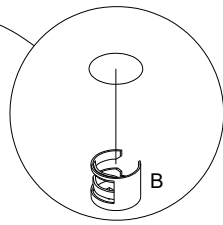

ASSEMBLY INSTRUCTION

STEP 9

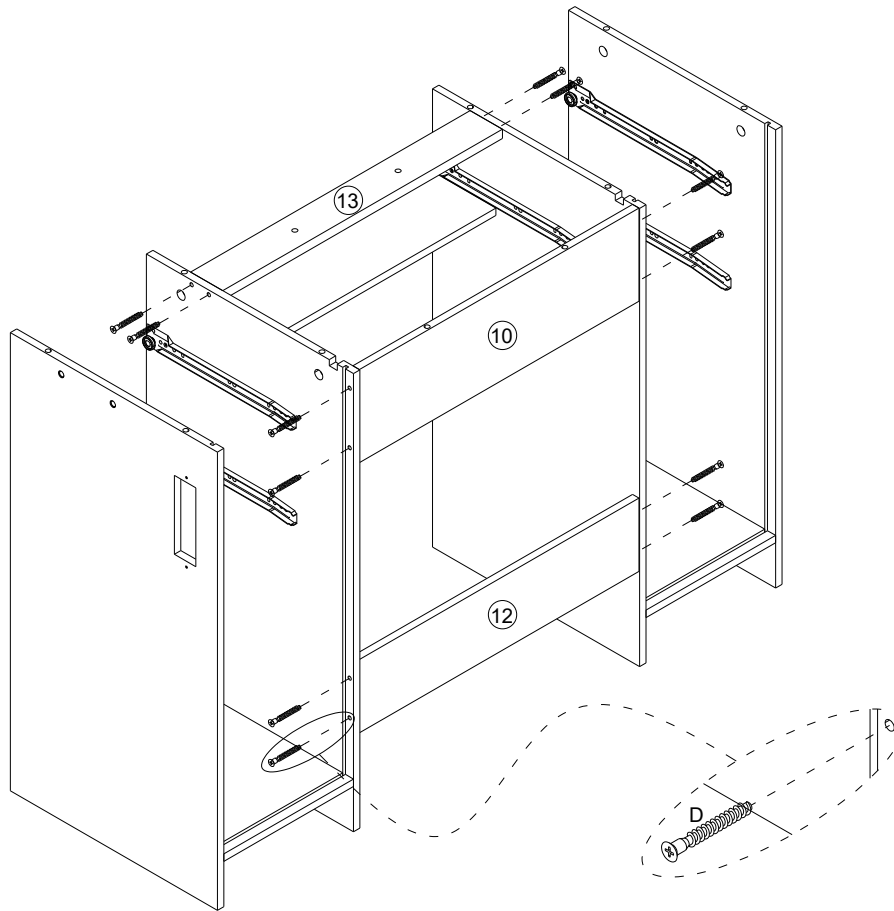

D 12PCS

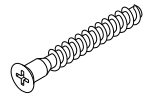

STEP 10

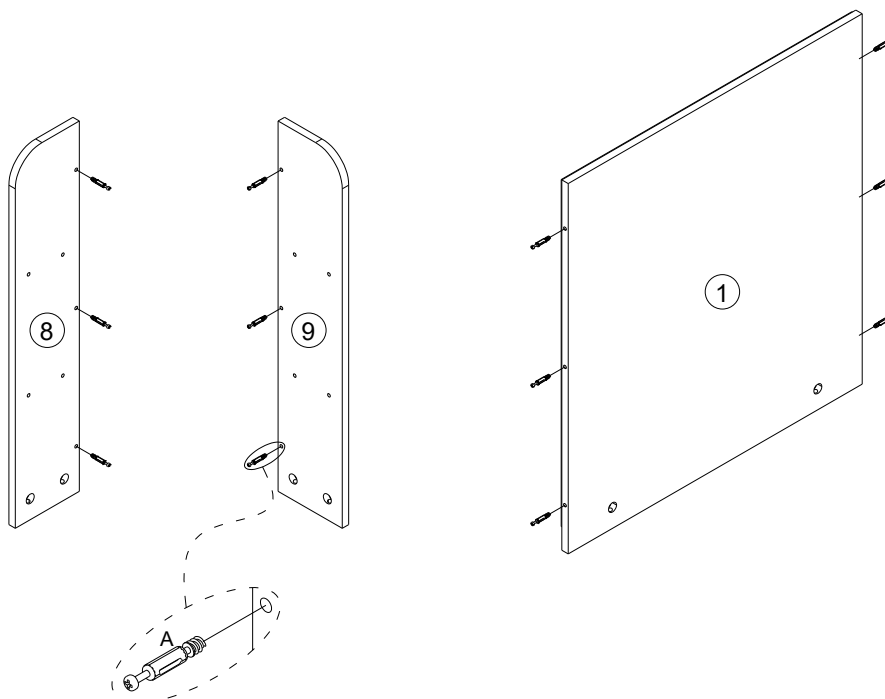

A 12PCS

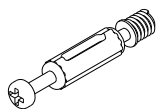

ASSEMBLY INSTRUCTION

STEP11

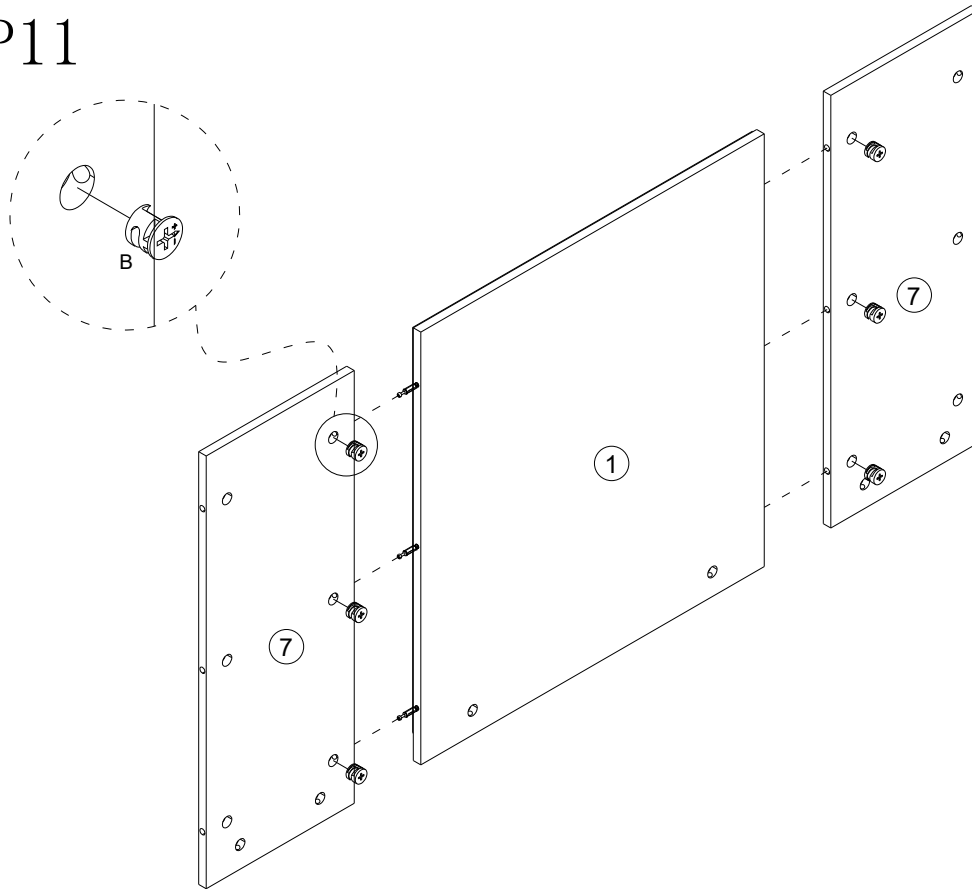

B 6PCS



STEP12

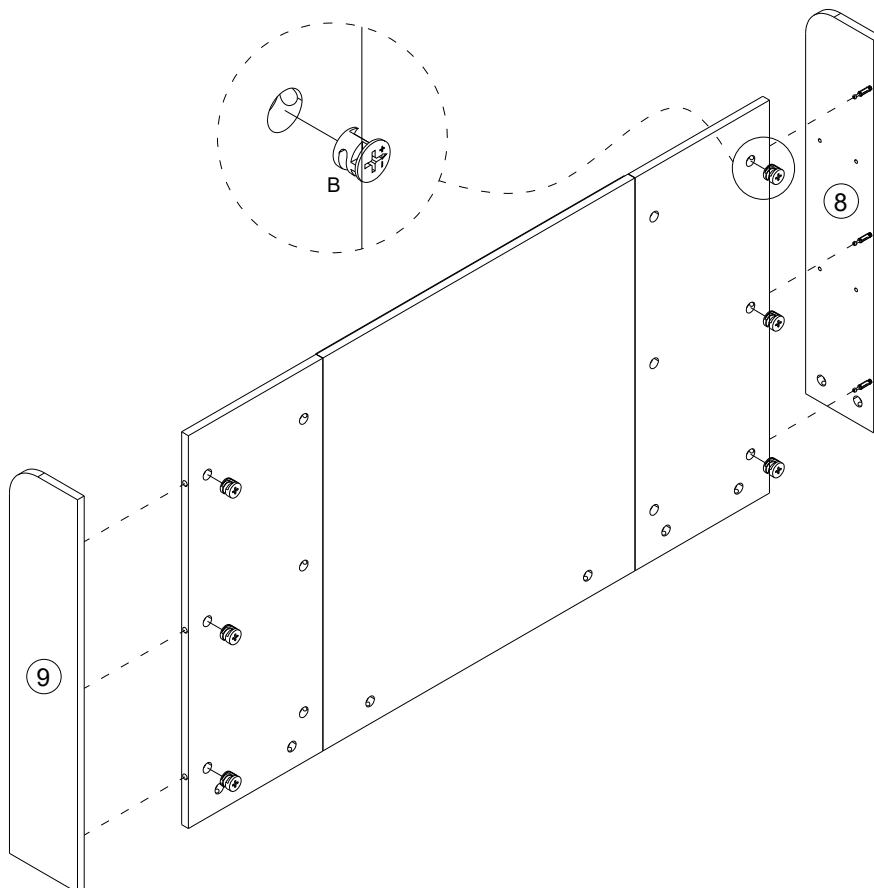

B 6PCS



ASSEMBLY INSTRUCTION

STEP13

A 10PCS

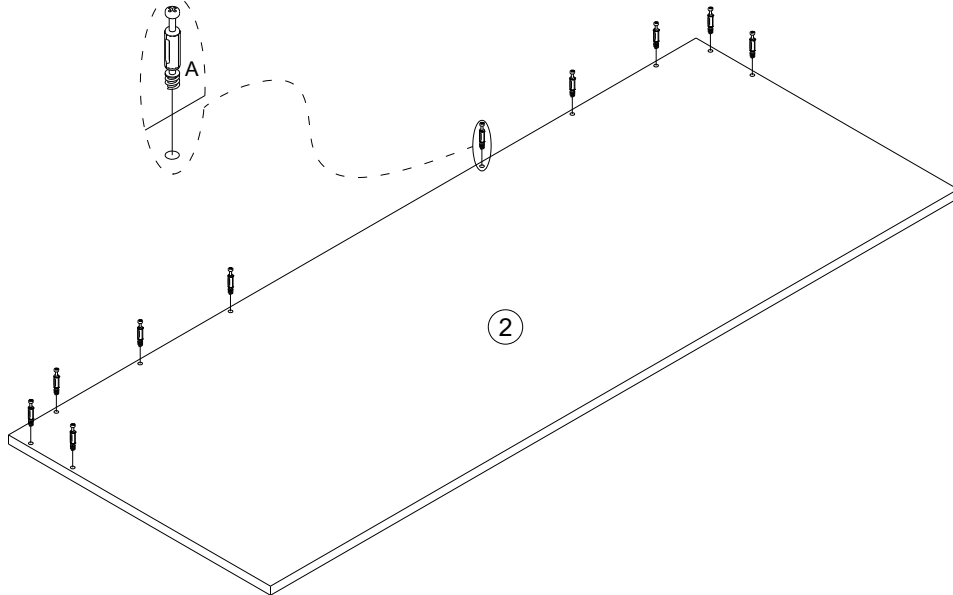
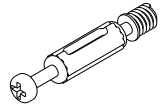

STEP14

B 10PCS

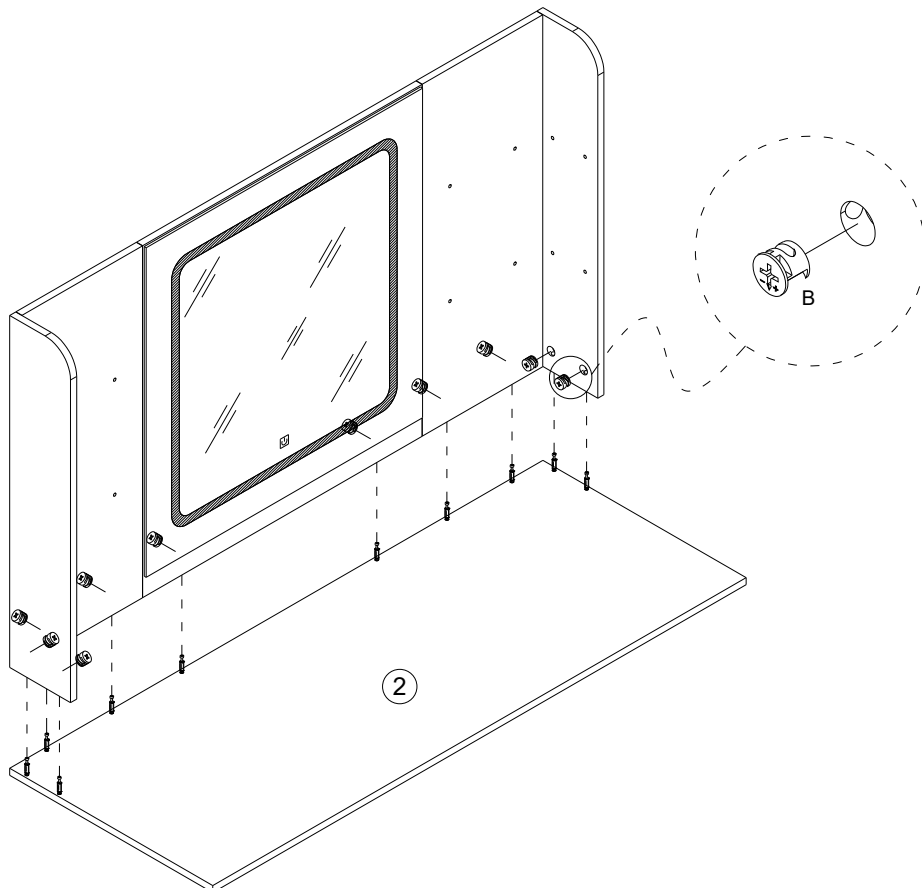

ASSEMBLY INSTRUCTION

STEP15

A 10PCS

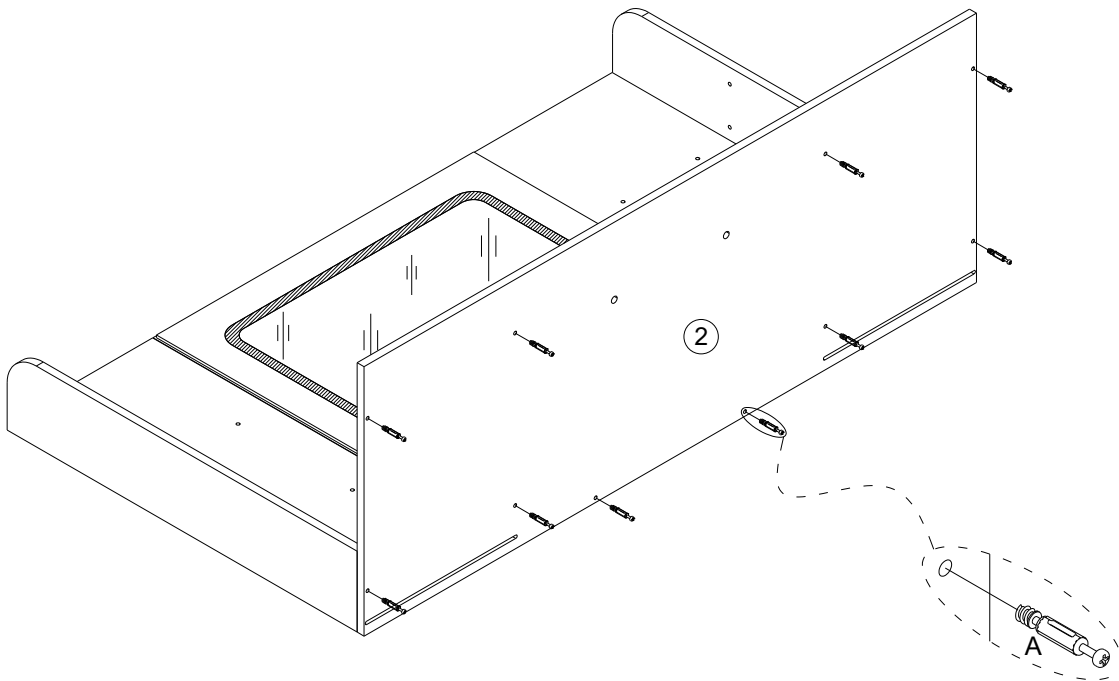
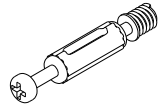

STEP16

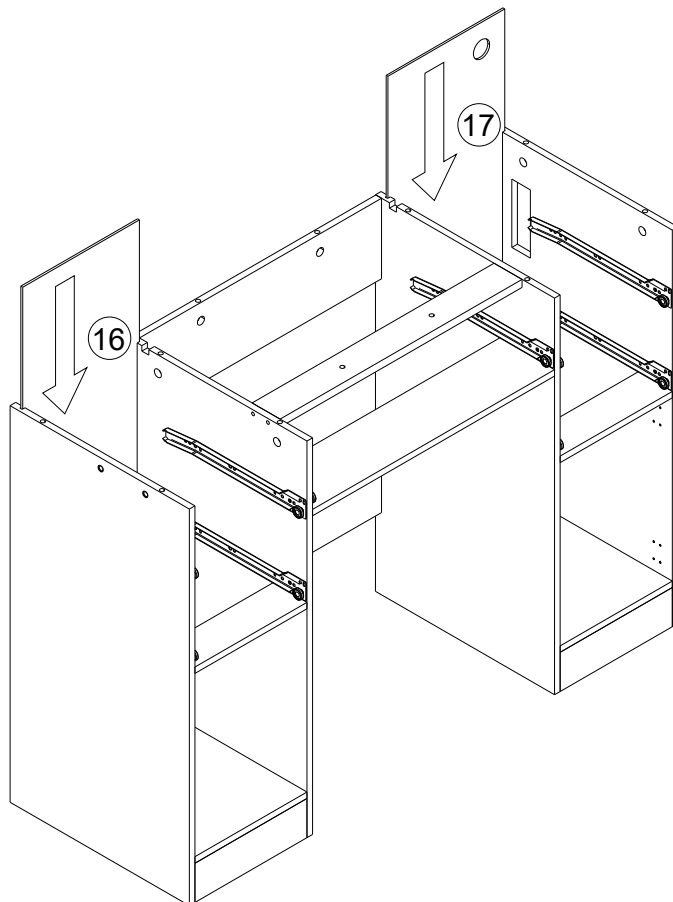

ASSEMBLY INSTRUCTION

STEP17

B 10PCS



L 2PCS

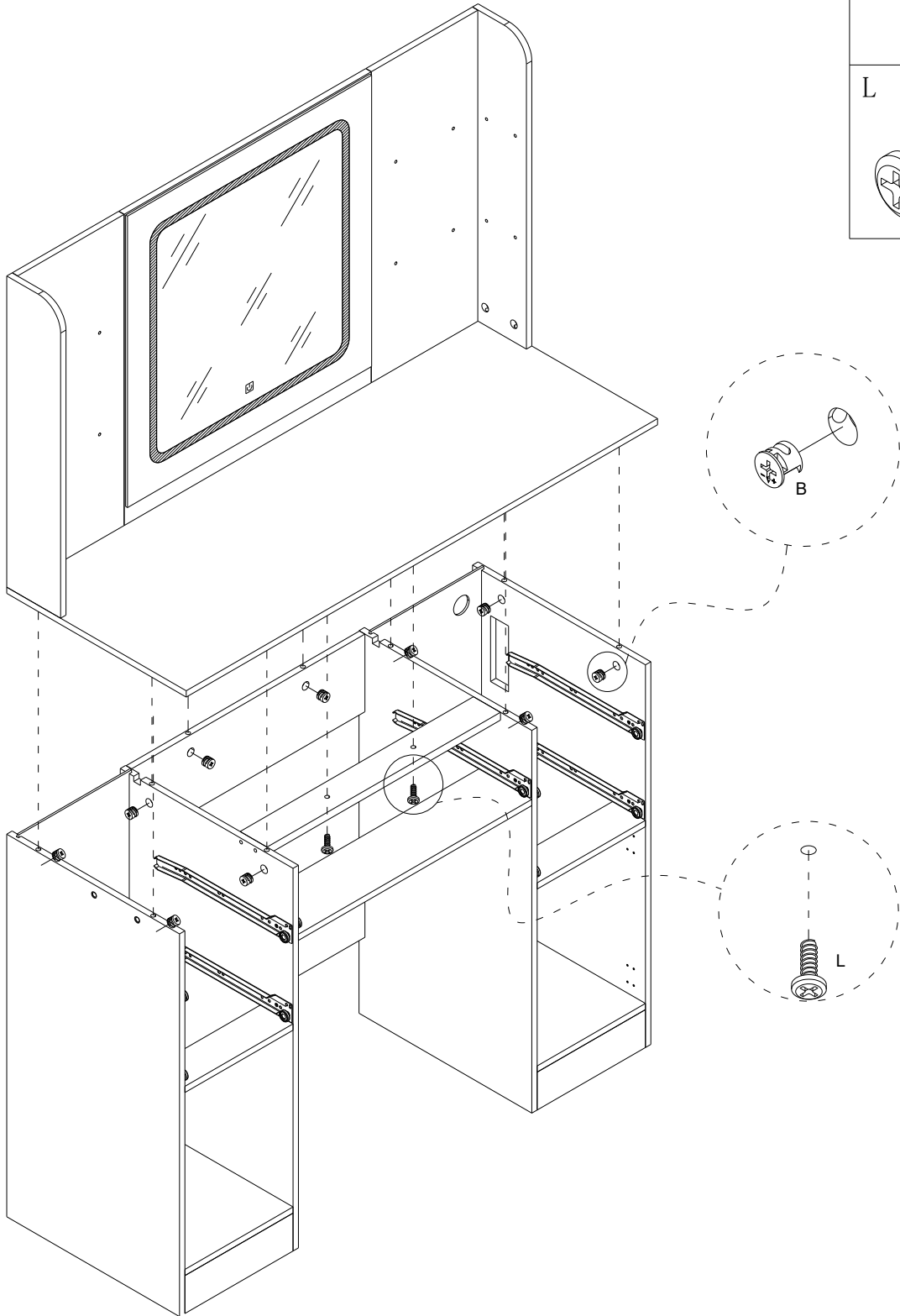
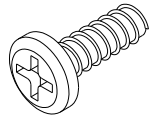

ASSEMBLY INSTRUCTION

STEP18

E 4PCS



T 1PCS





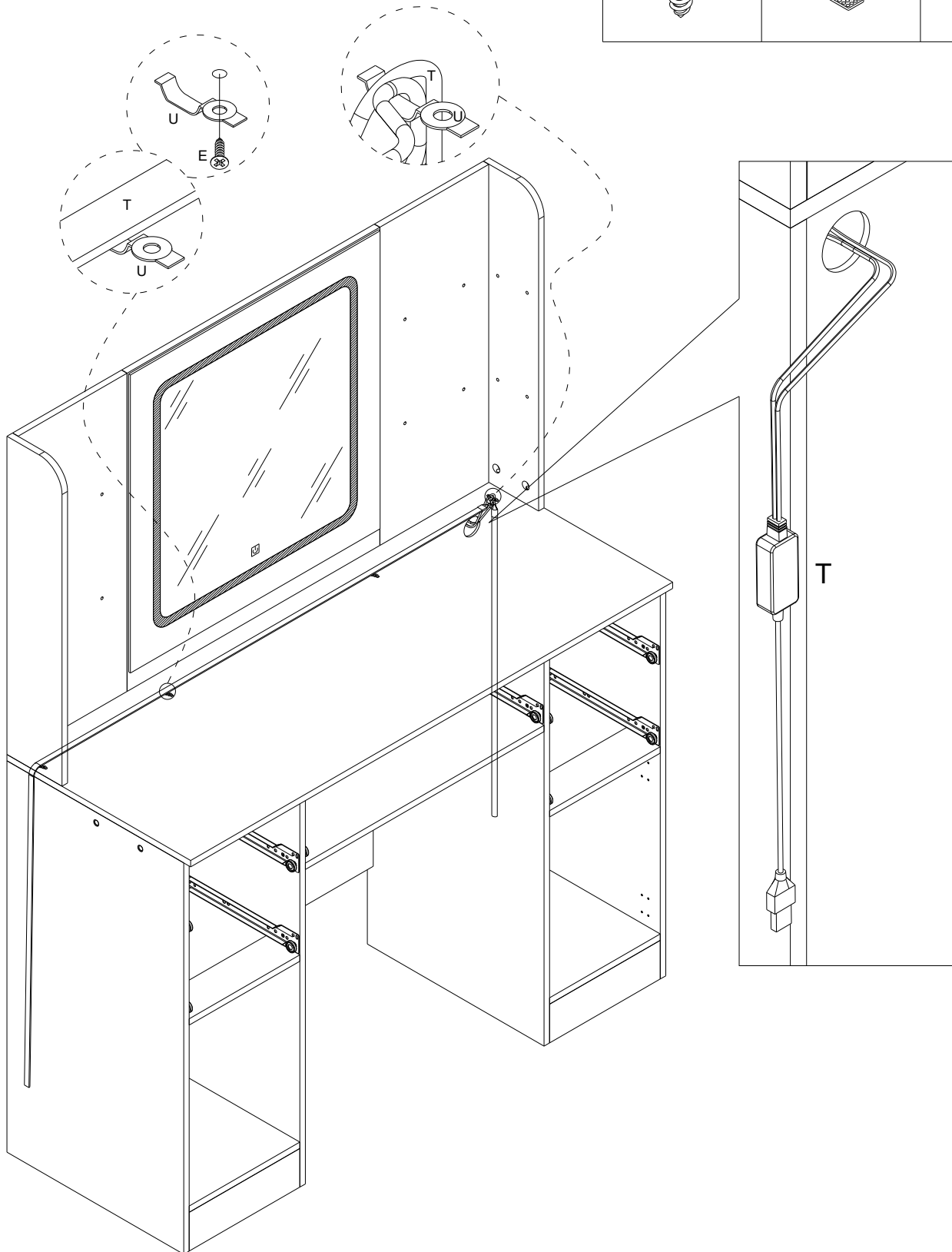
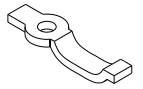

U 4PCS

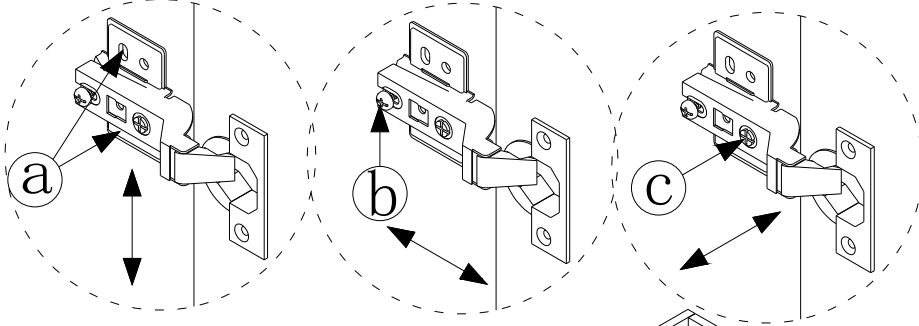

ASSEMBLY INSTRUCTION

STEP 19

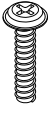
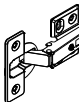

E 12PCS	S 1PC
	
M 1PC	K 1PC
	

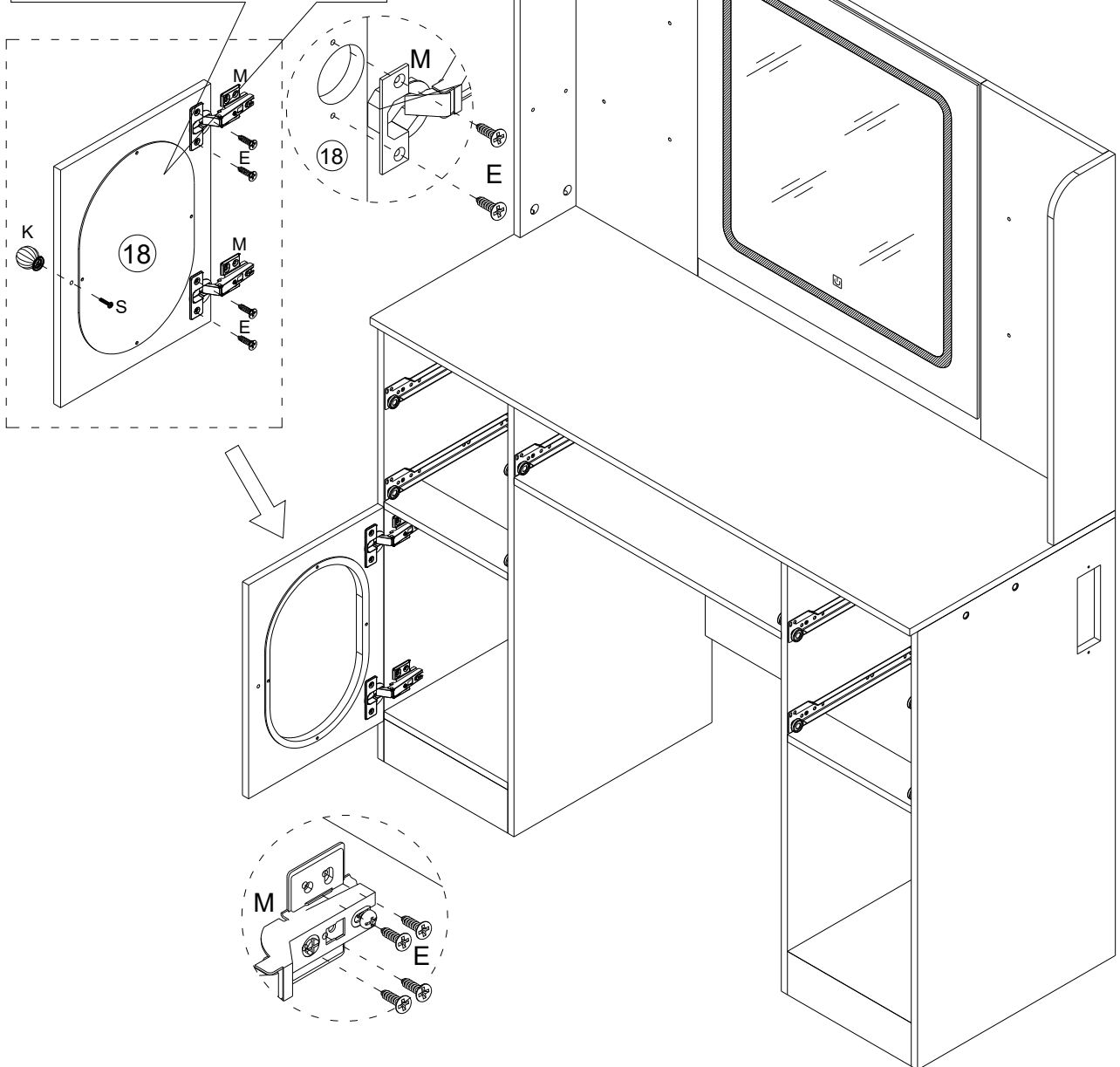

Remove the protective film from this area before installation.

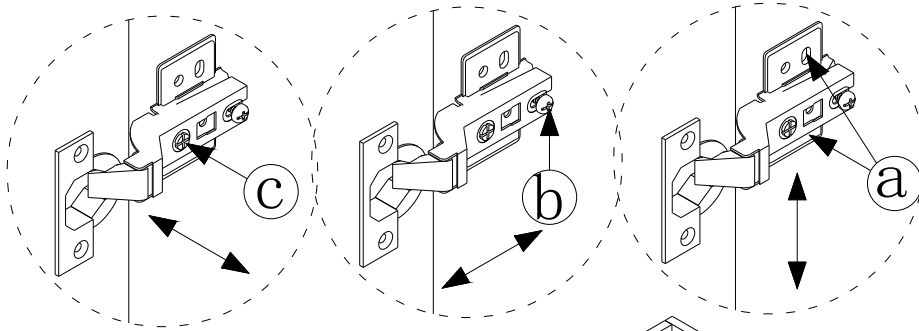

ASSEMBLY INSTRUCTION

STEP 20

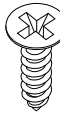

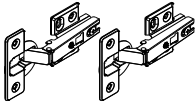
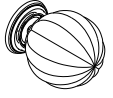
E 12PCS	S 1PC
	
M 1PC	K 1PC
	

Remove the protective film from this area before installation.

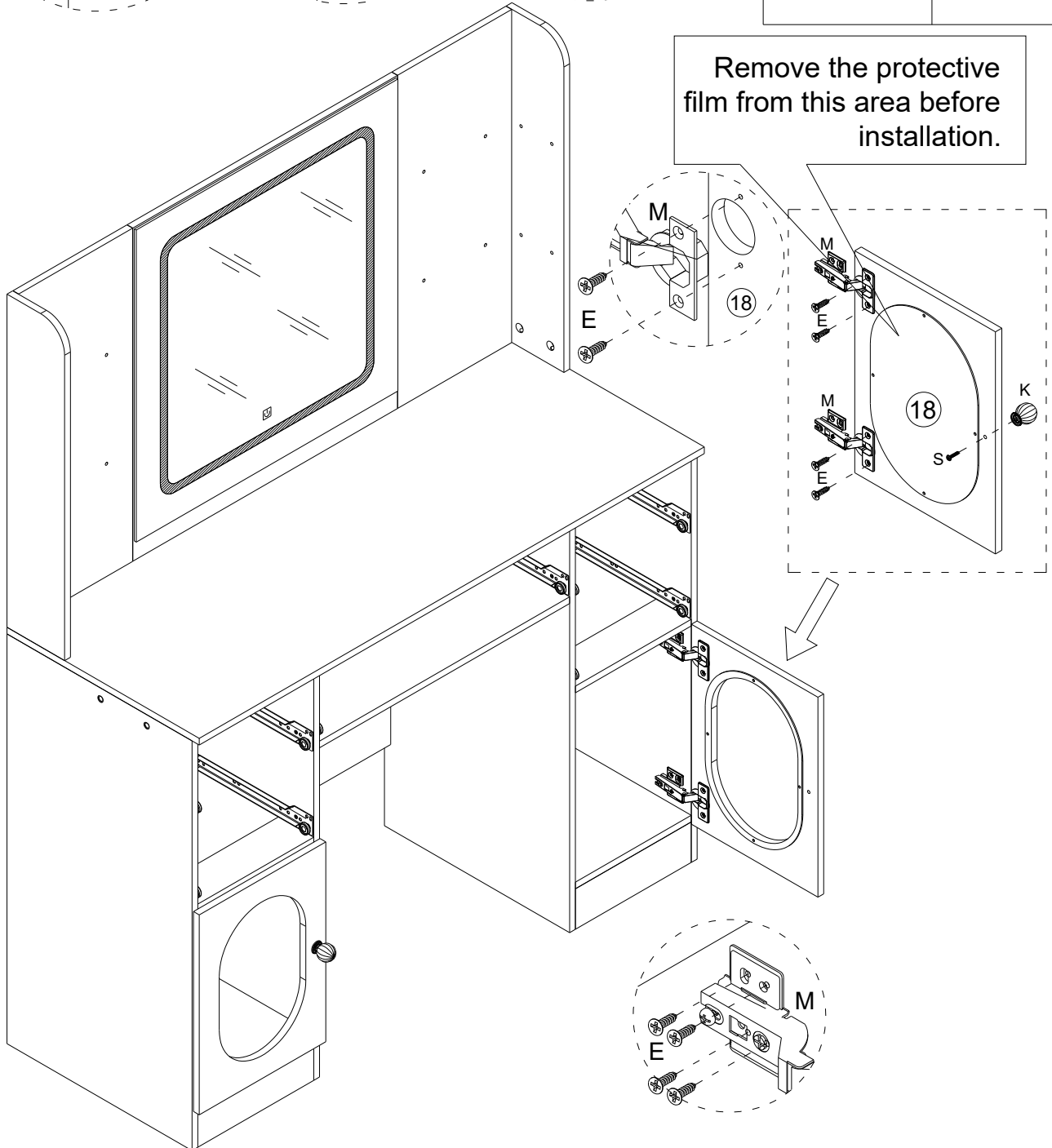

ASSEMBLY INSTRUCTION

STEP21

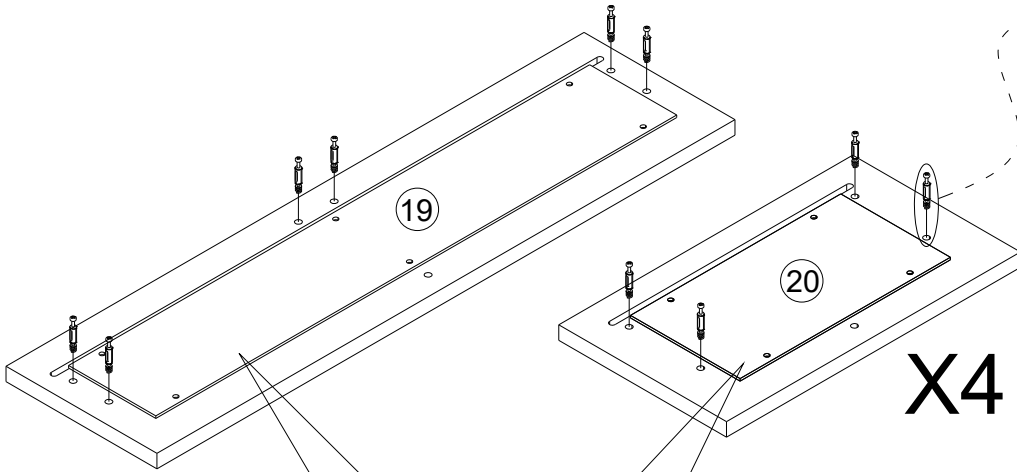

A 22PCS

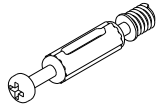

Remove the protective film from this area before installation.

STEP22

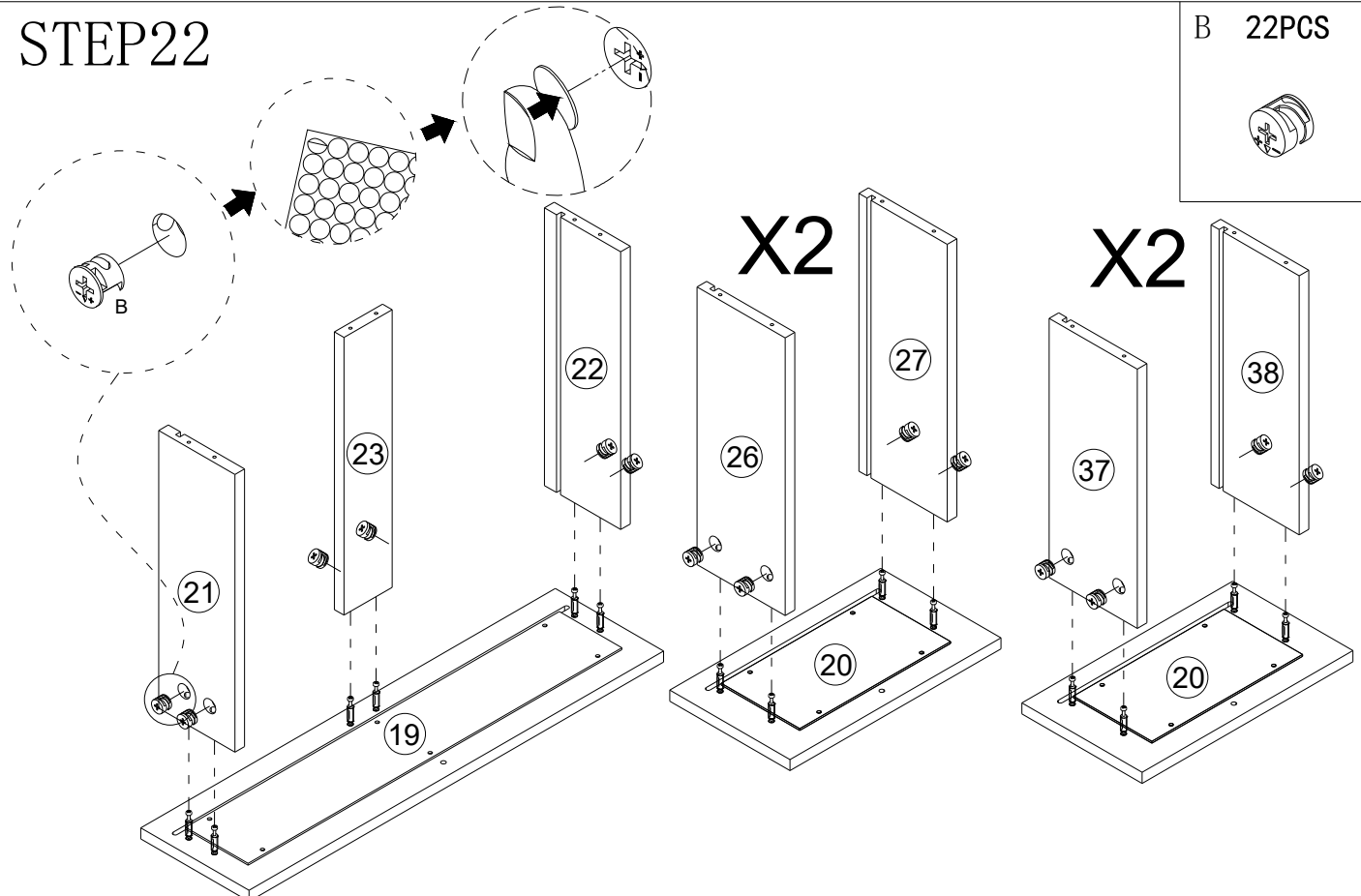

B 22PCS



ASSEMBLY INSTRUCTION

STEP23

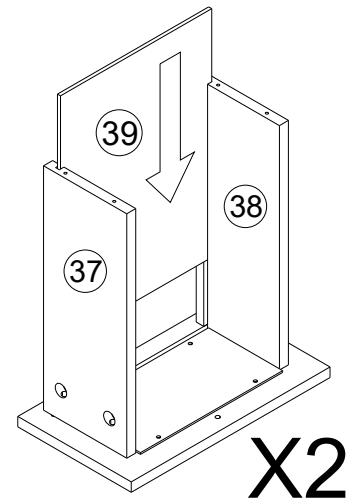
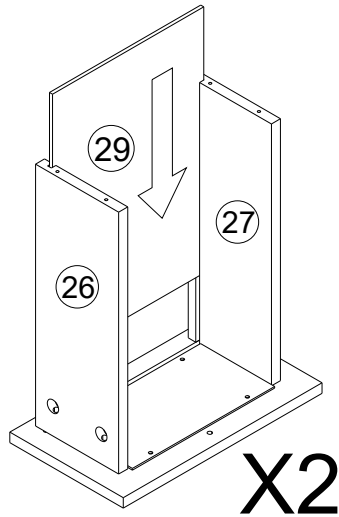
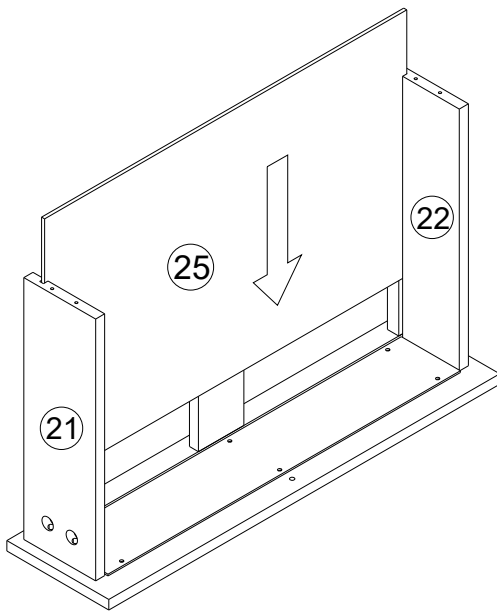

STEP24

C 22PCS

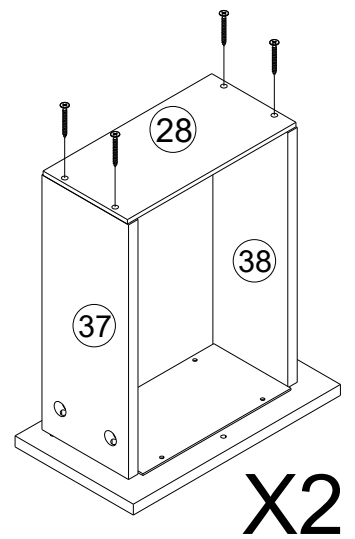
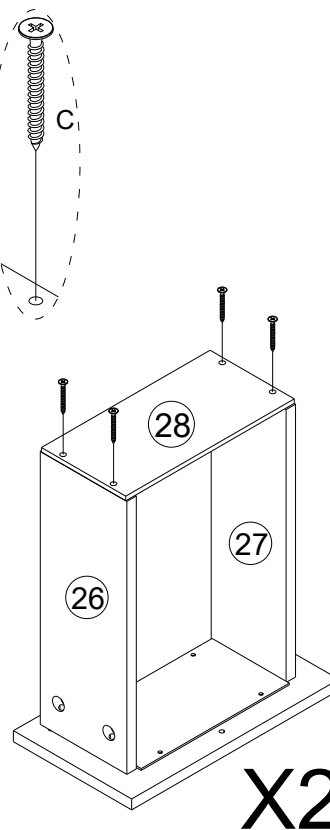
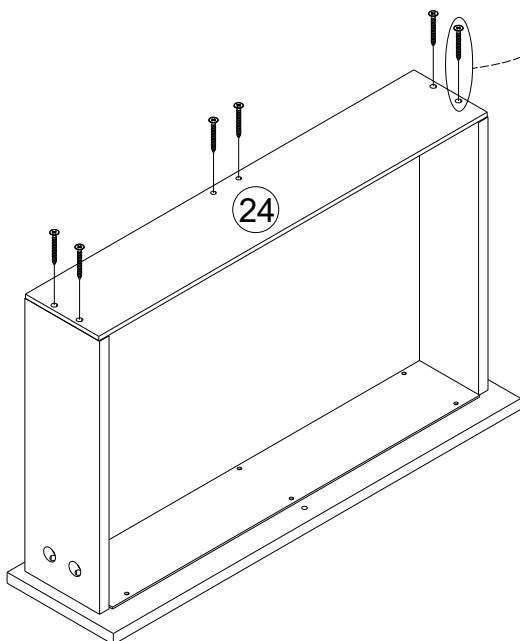
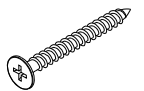

ASSEMBLY INSTRUCTION

STEP25

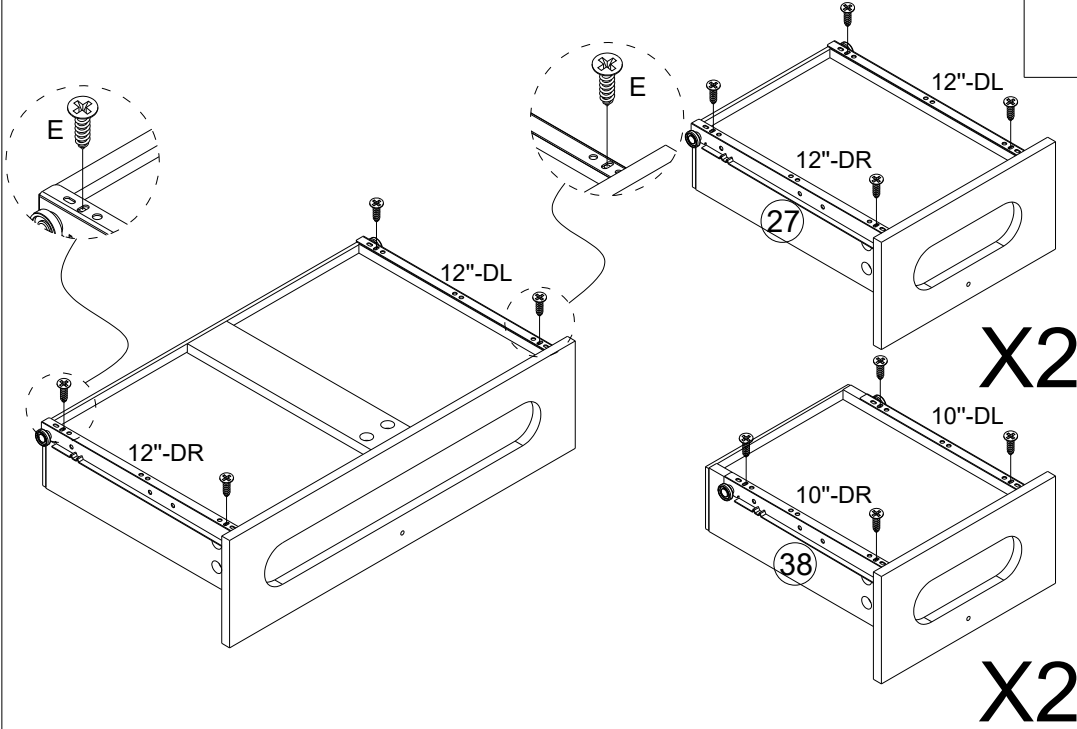

E 20PCS



3PCS

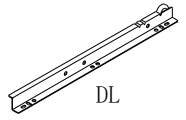

DL

3PCS

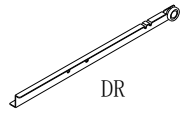

DR

2PCS

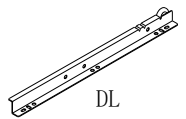

DL

2PCS

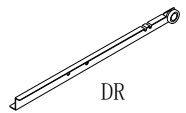

DR

X2

X2

STEP26

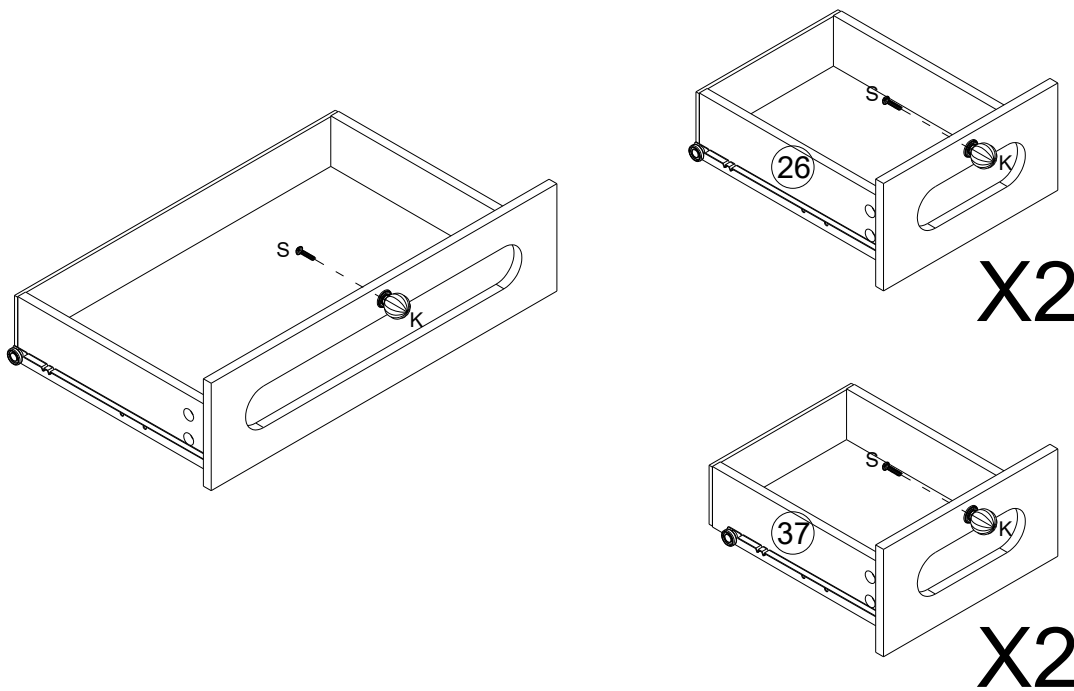

S 5PCS



K 5PCS



X2

X2

ASSEMBLY INSTRUCTION

STEP 27

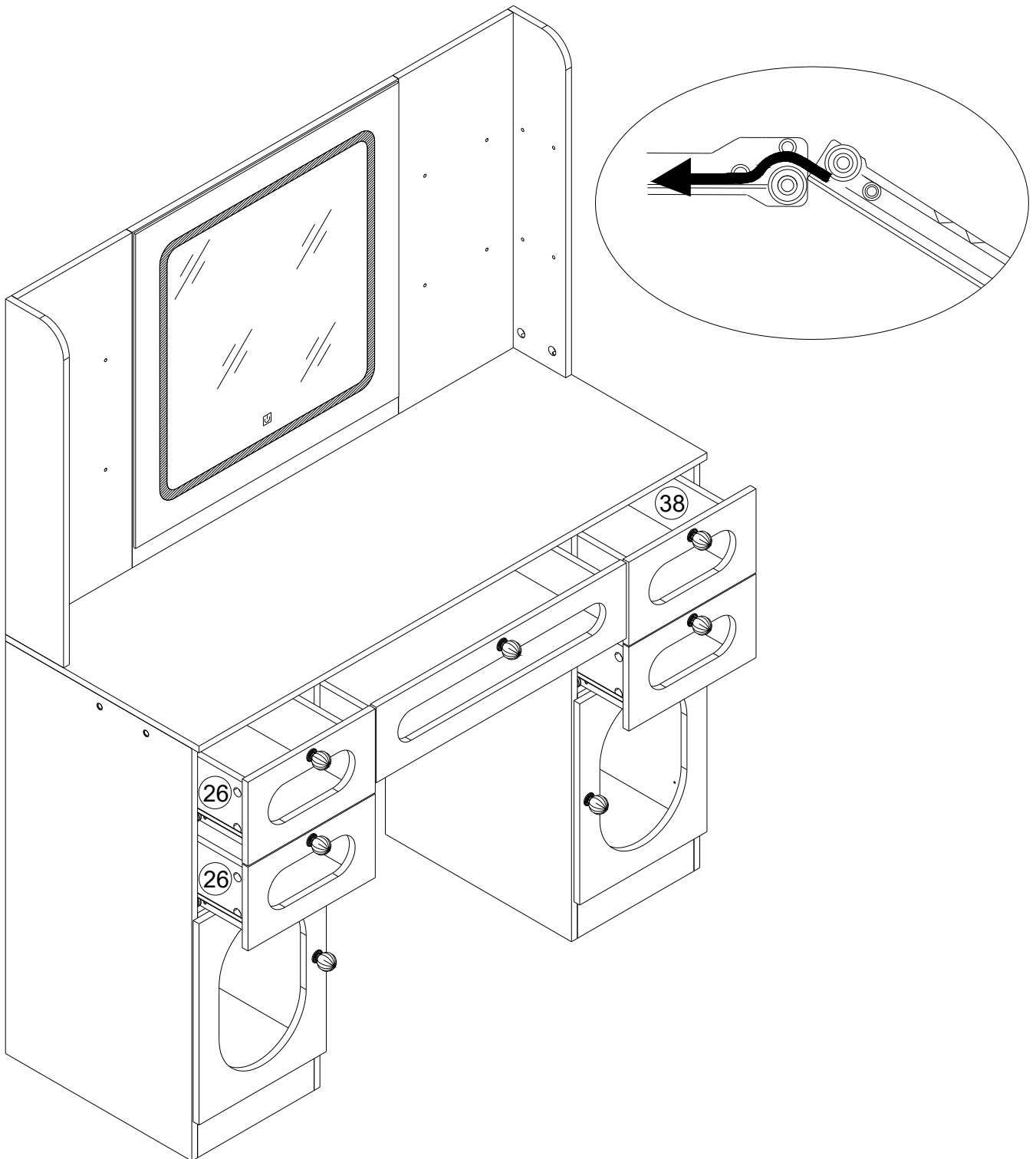

ASSEMBLY INSTRUCTION

STEP 28

E 2PCS



H 1PC

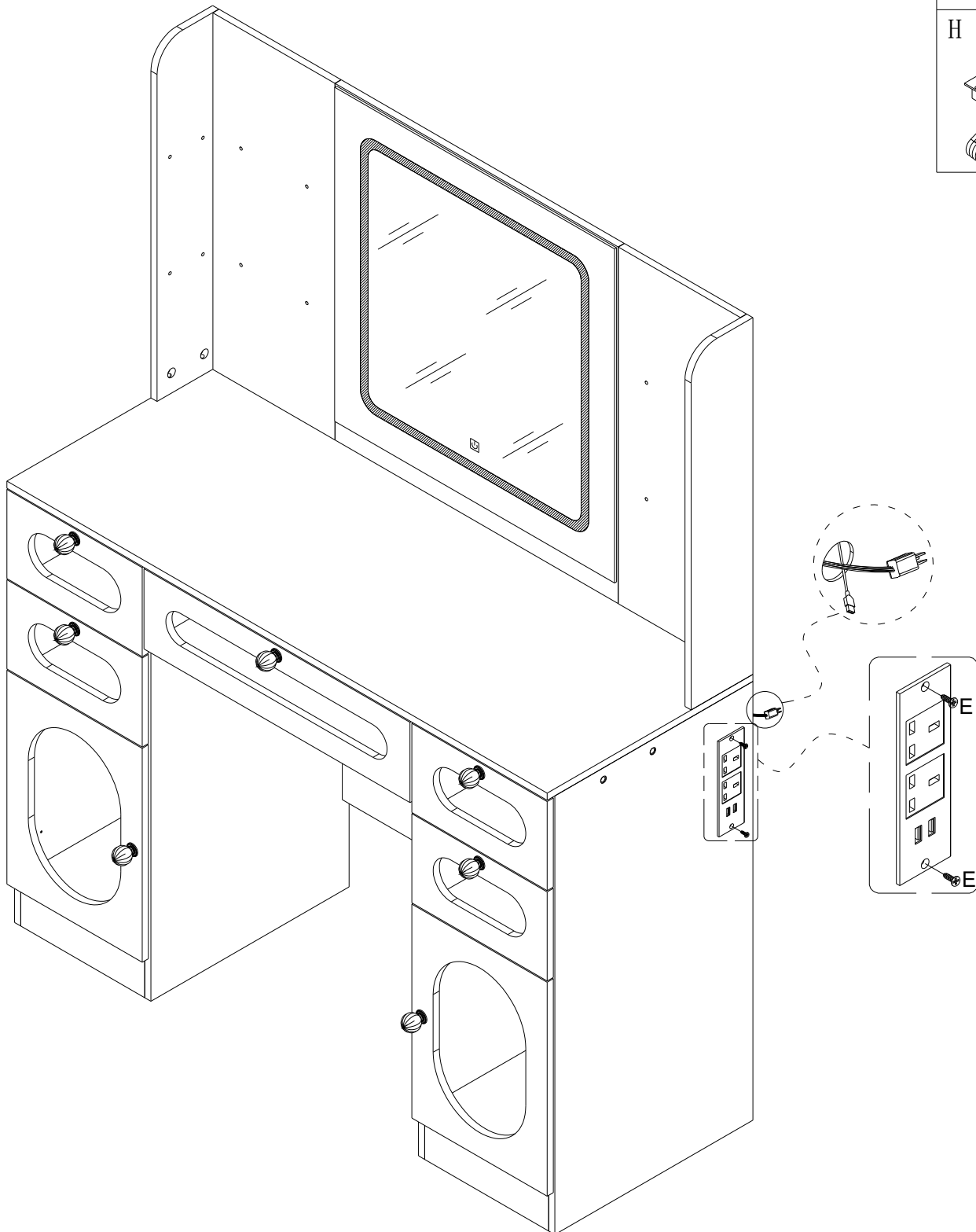
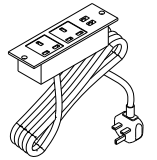

ASSEMBLY INSTRUCTION

STEP29

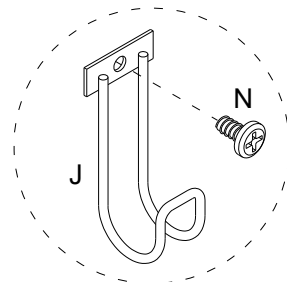
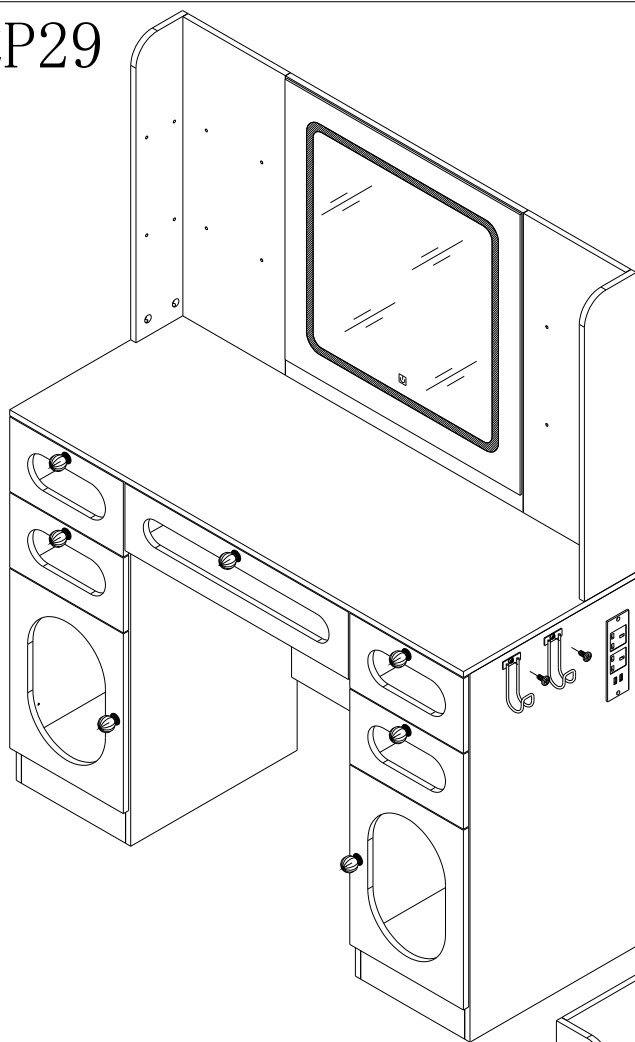

OR

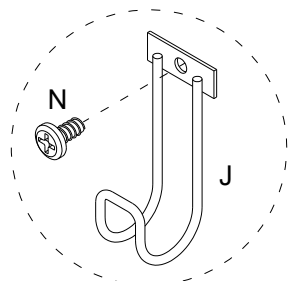
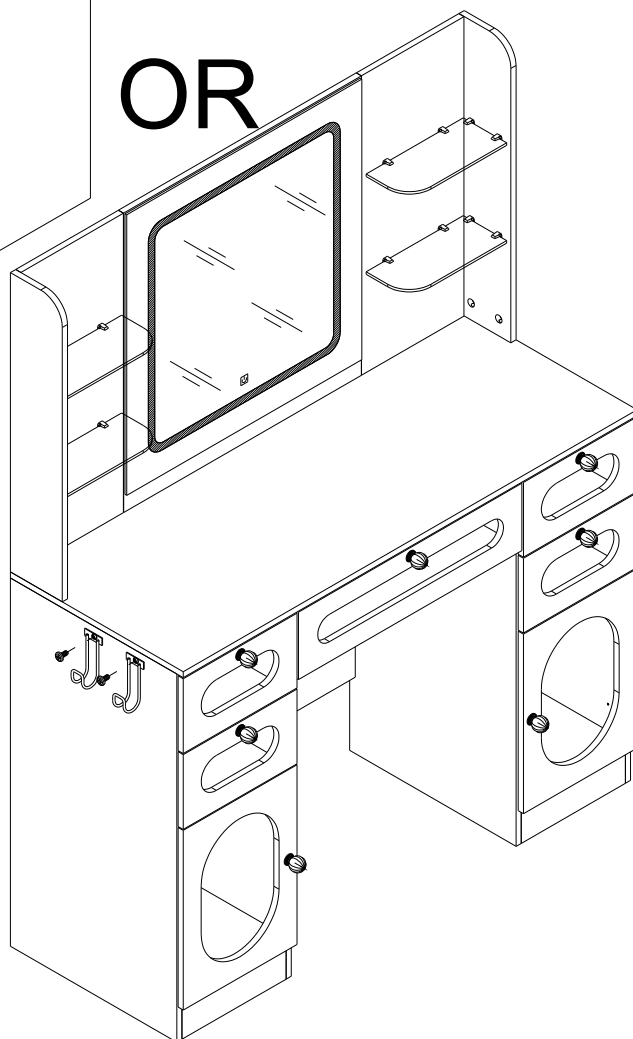

N 2PCS



J 2PCS

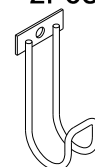

ASSEMBLY INSTRUCTION

STEP27

Q 16PCS

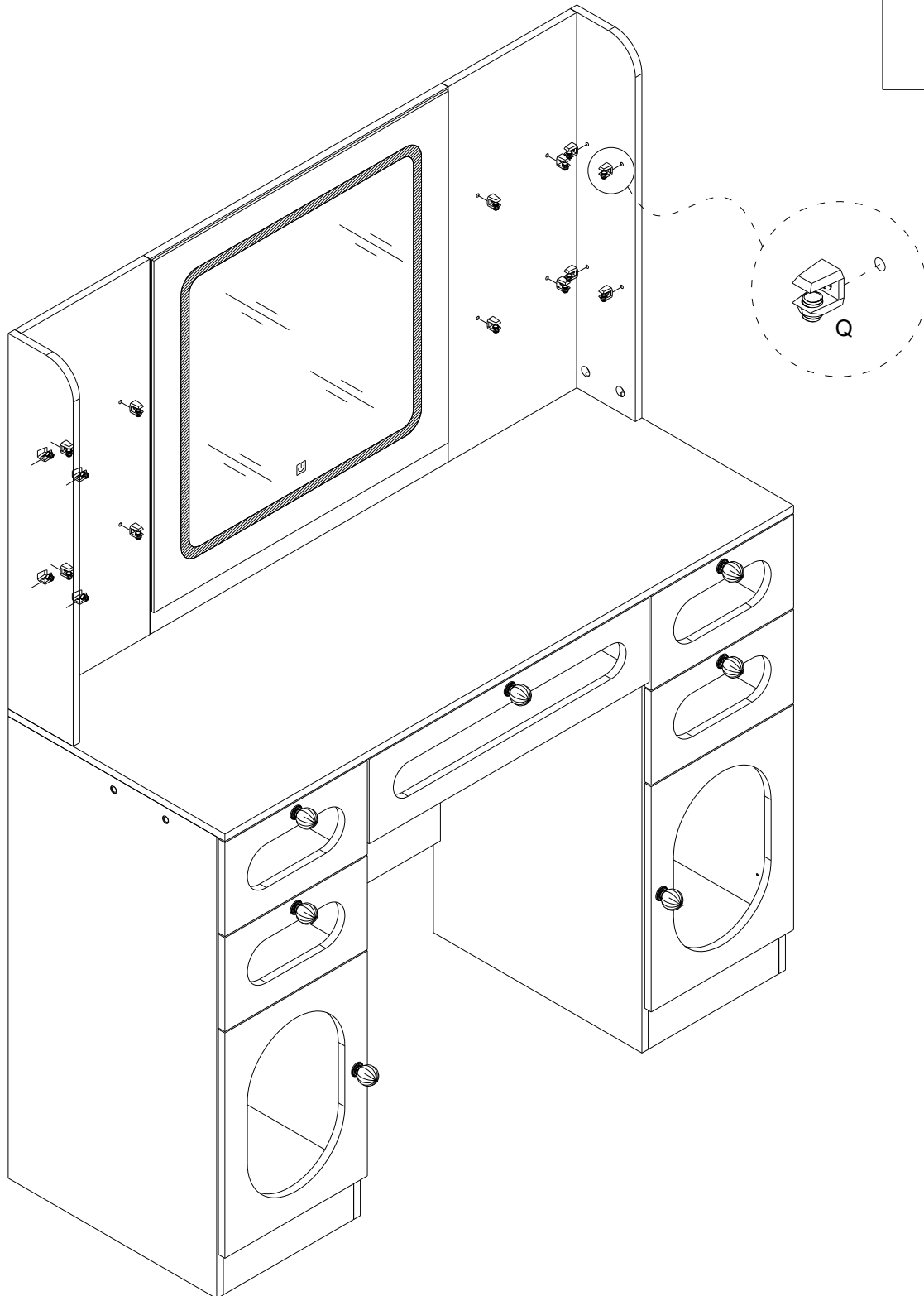

ASSEMBLY INSTRUCTION

STEP 28

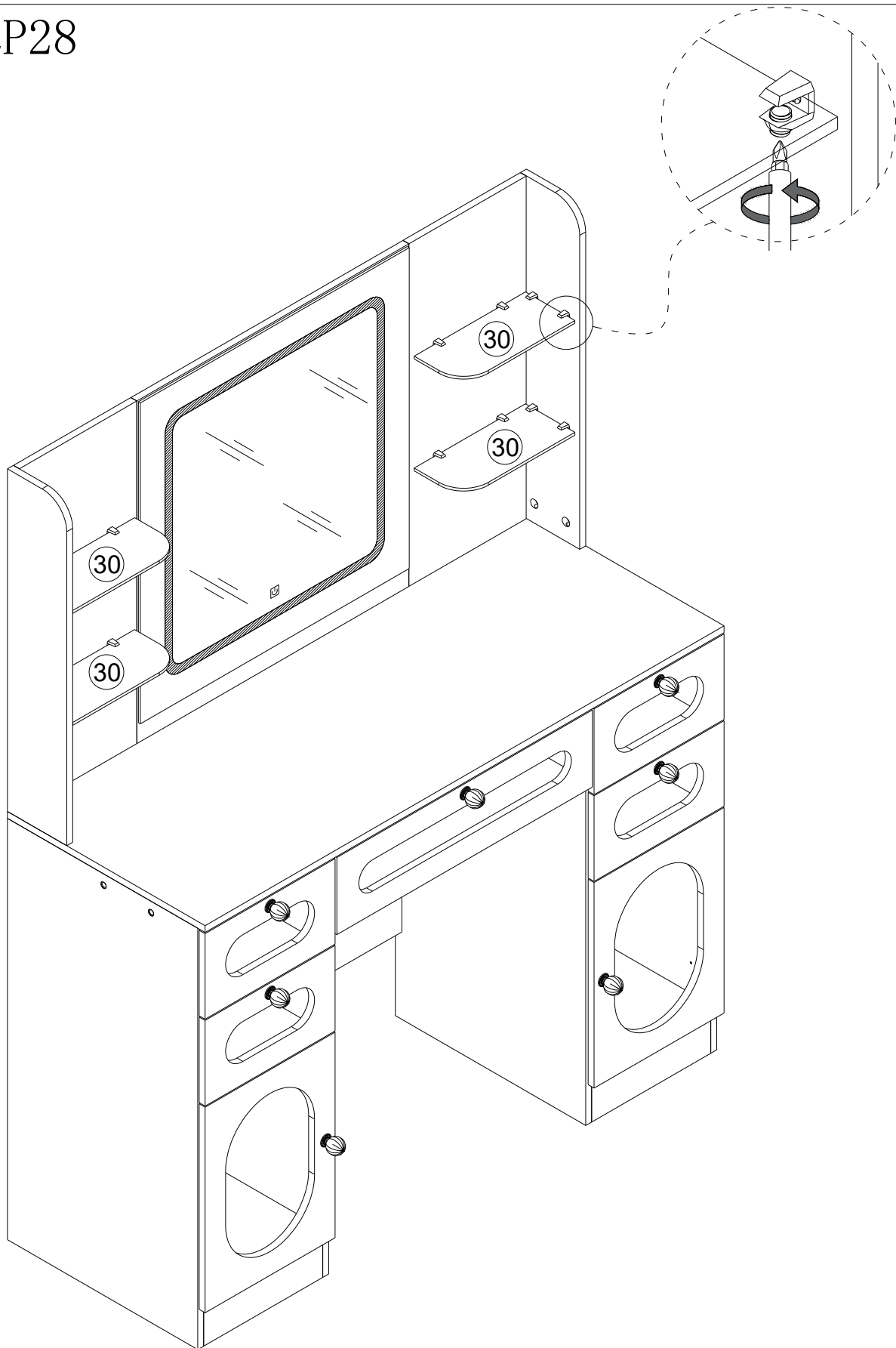

ASSEMBLY INSTRUCTION

STEP29

I 12PCS	W 1PC
V 1PC	

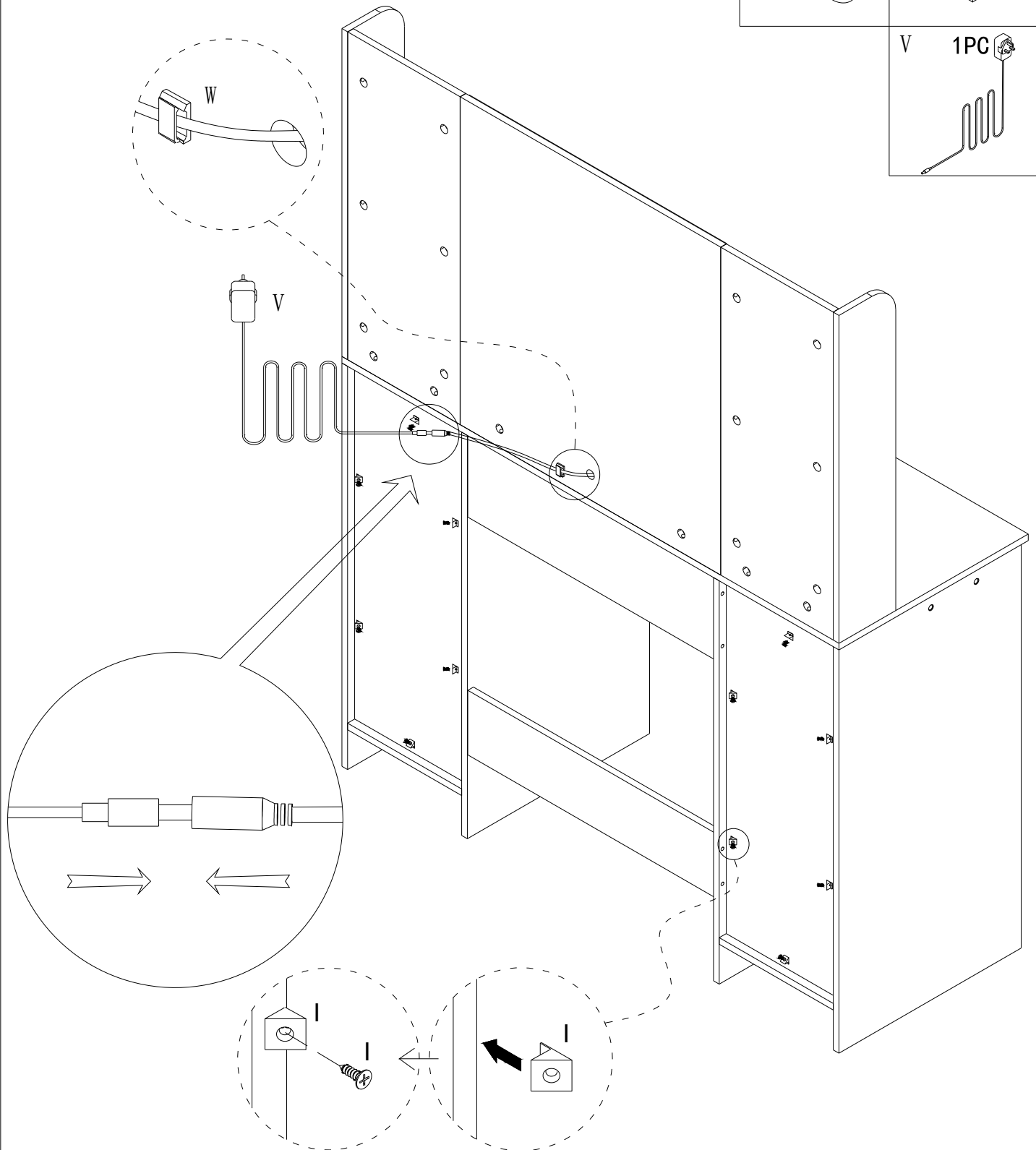

ASSEMBLY INSTRUCTION

STEP30

0 2PCS

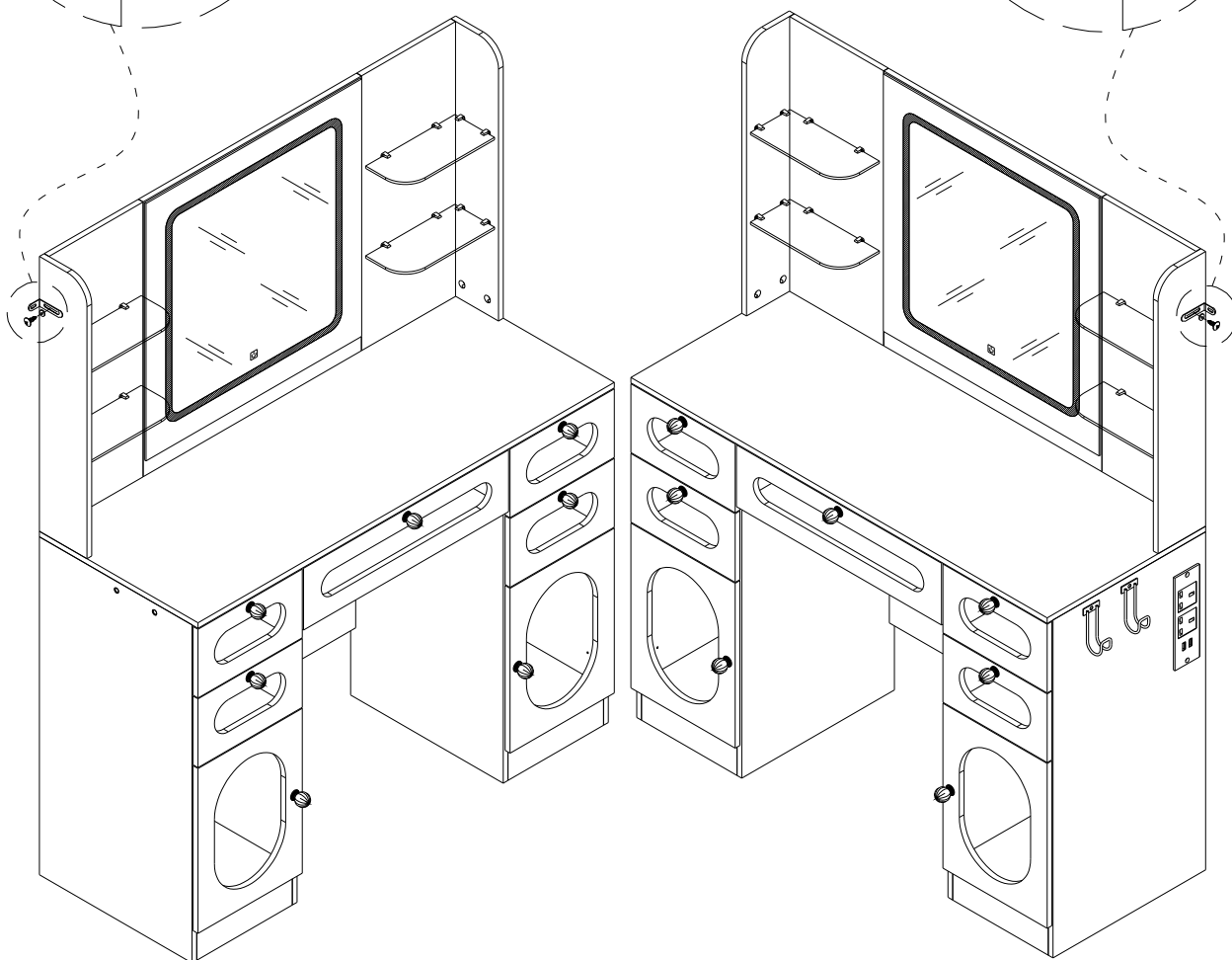
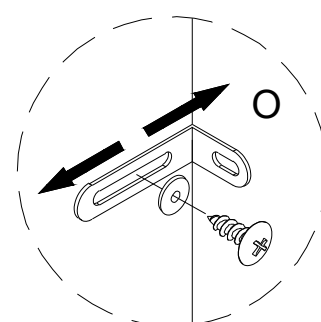
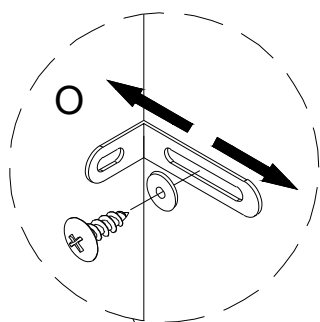
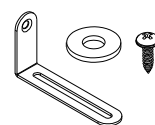

ASSEMBLY INSTRUCTION

STEP31

0 2PCS

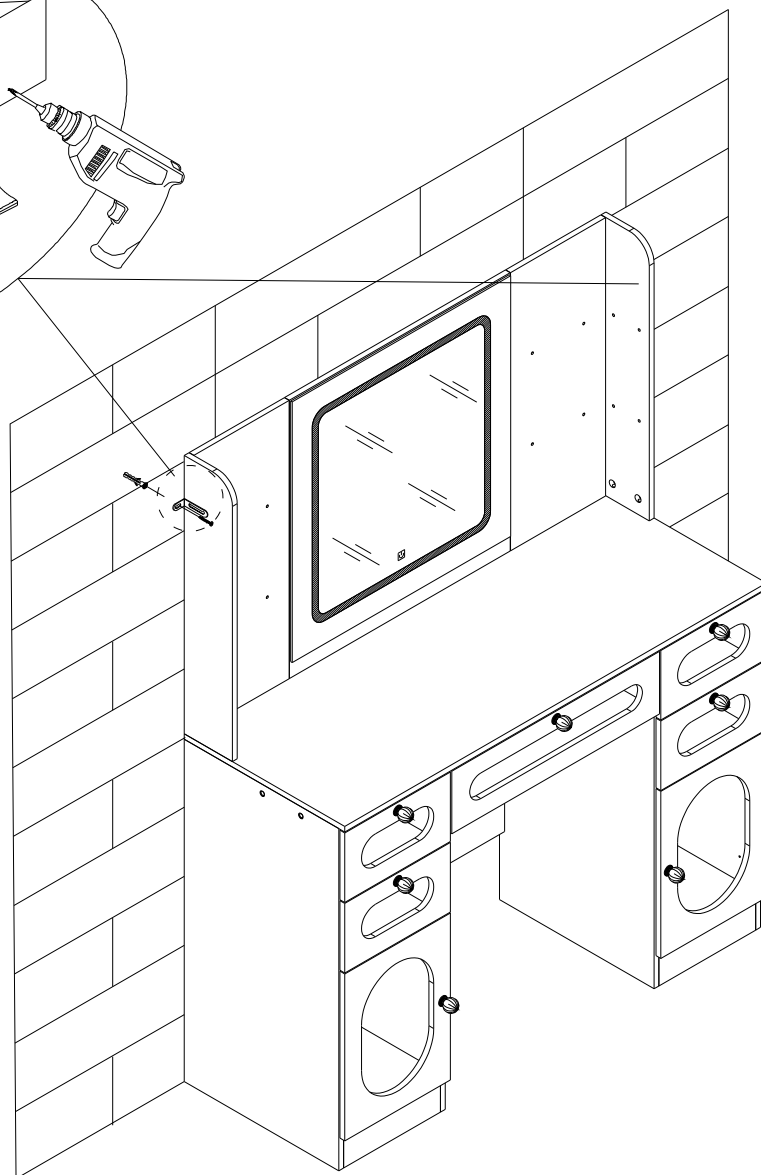
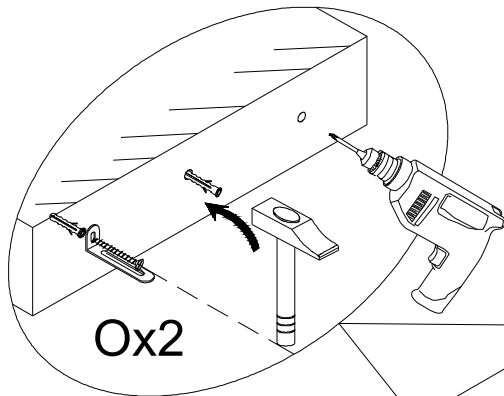
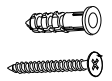

ASSEMBLY INSTRUCTION

STEP32

A 4PCS

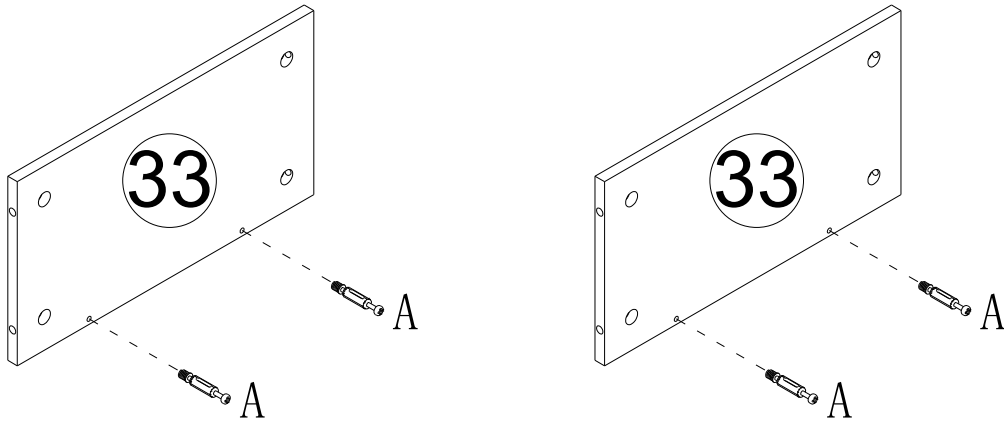
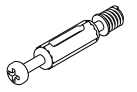

STEP33

B 4PCS

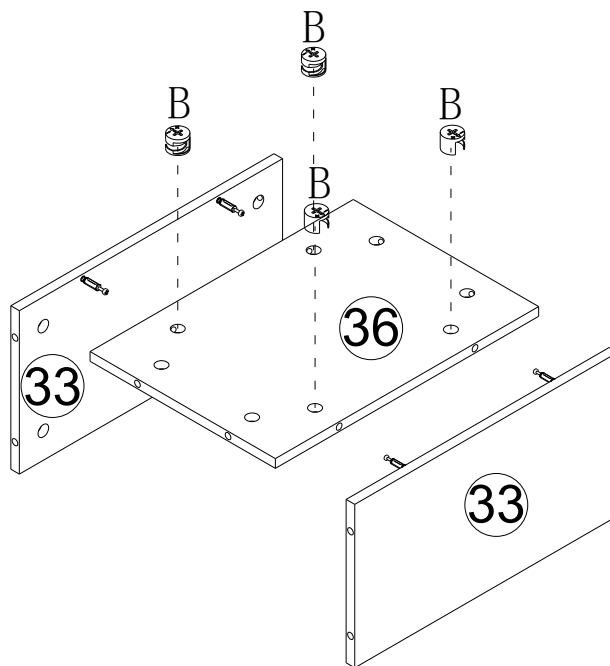

ASSEMBLY INSTRUCTION

STEP34

A 12PCS

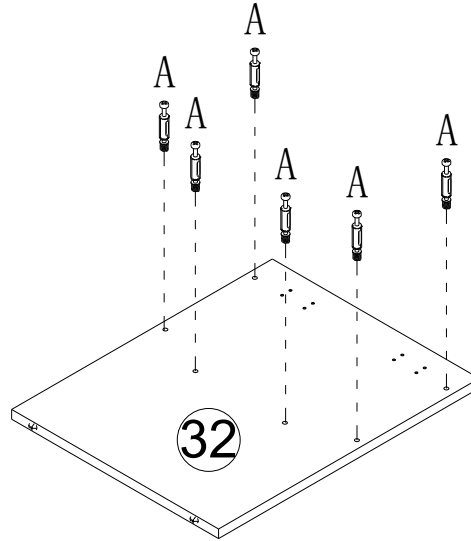
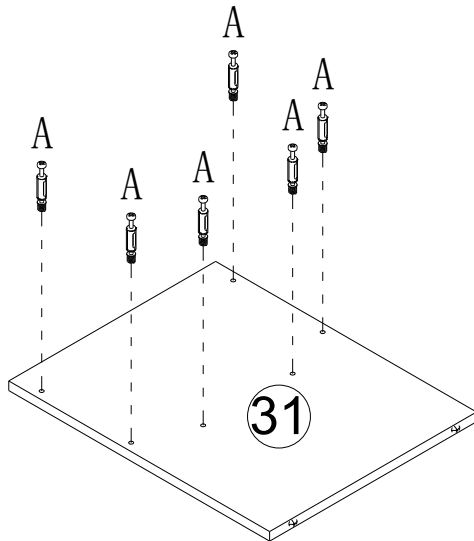
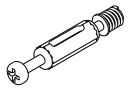

STEP35

B 6PCS

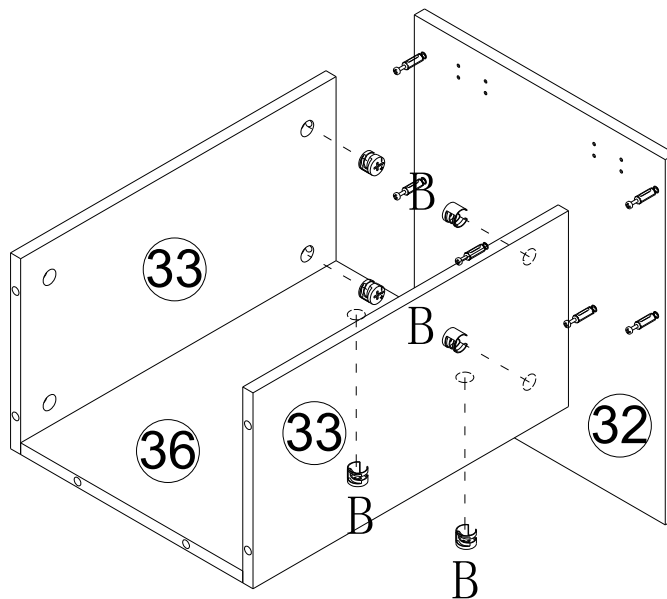

ASSEMBLY INSTRUCTION

STEP36

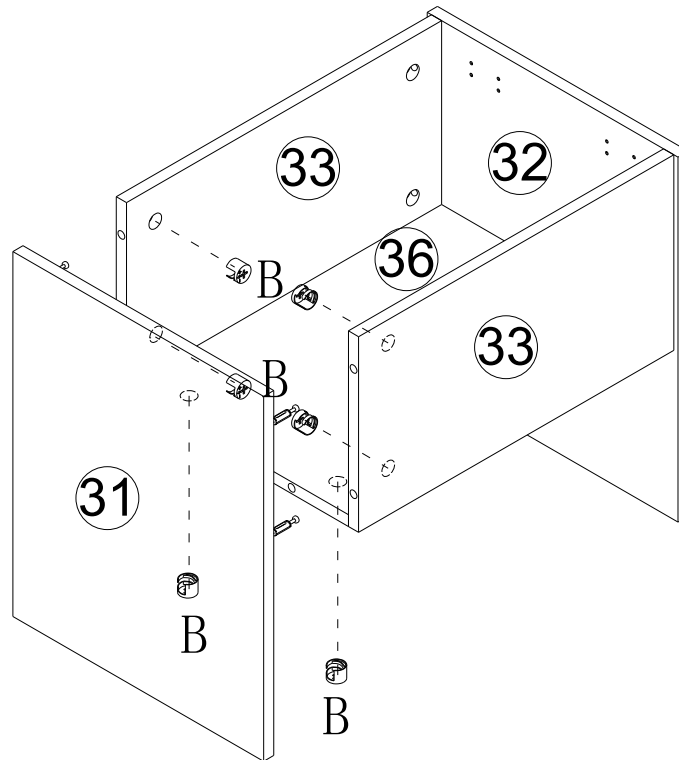

B 6PCS



STEP37

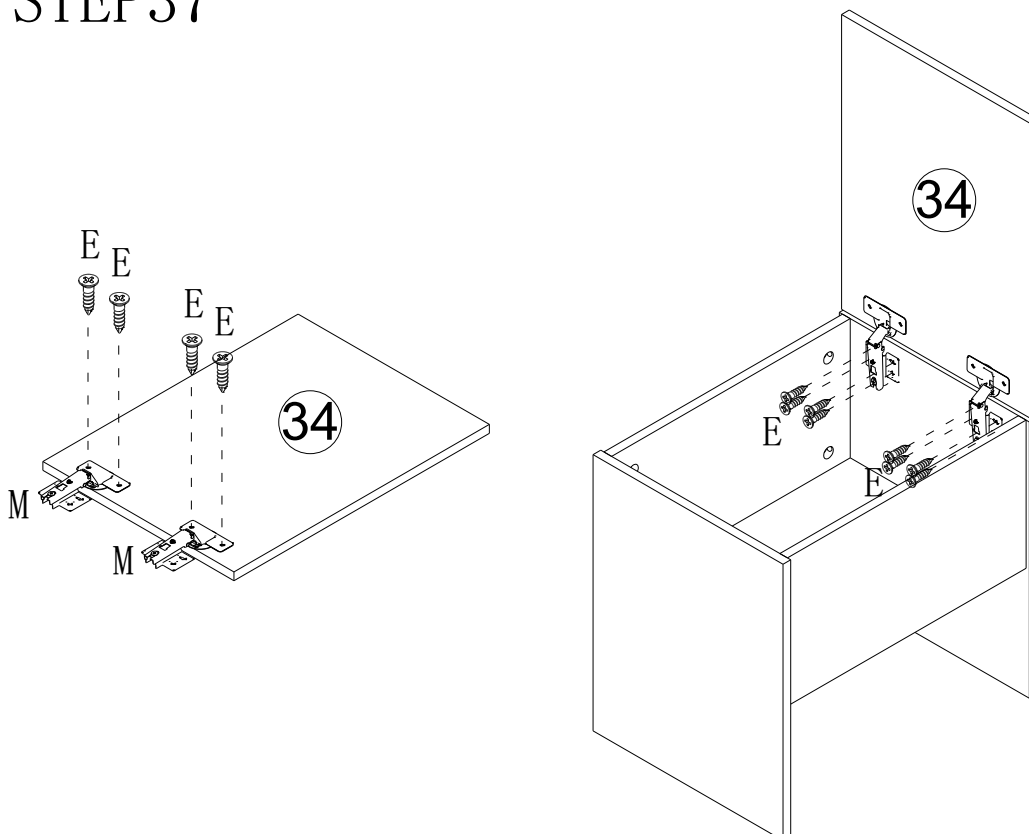

E 12PCS



M 1PC

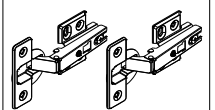

ASSEMBLY INSTRUCTION

STEP38

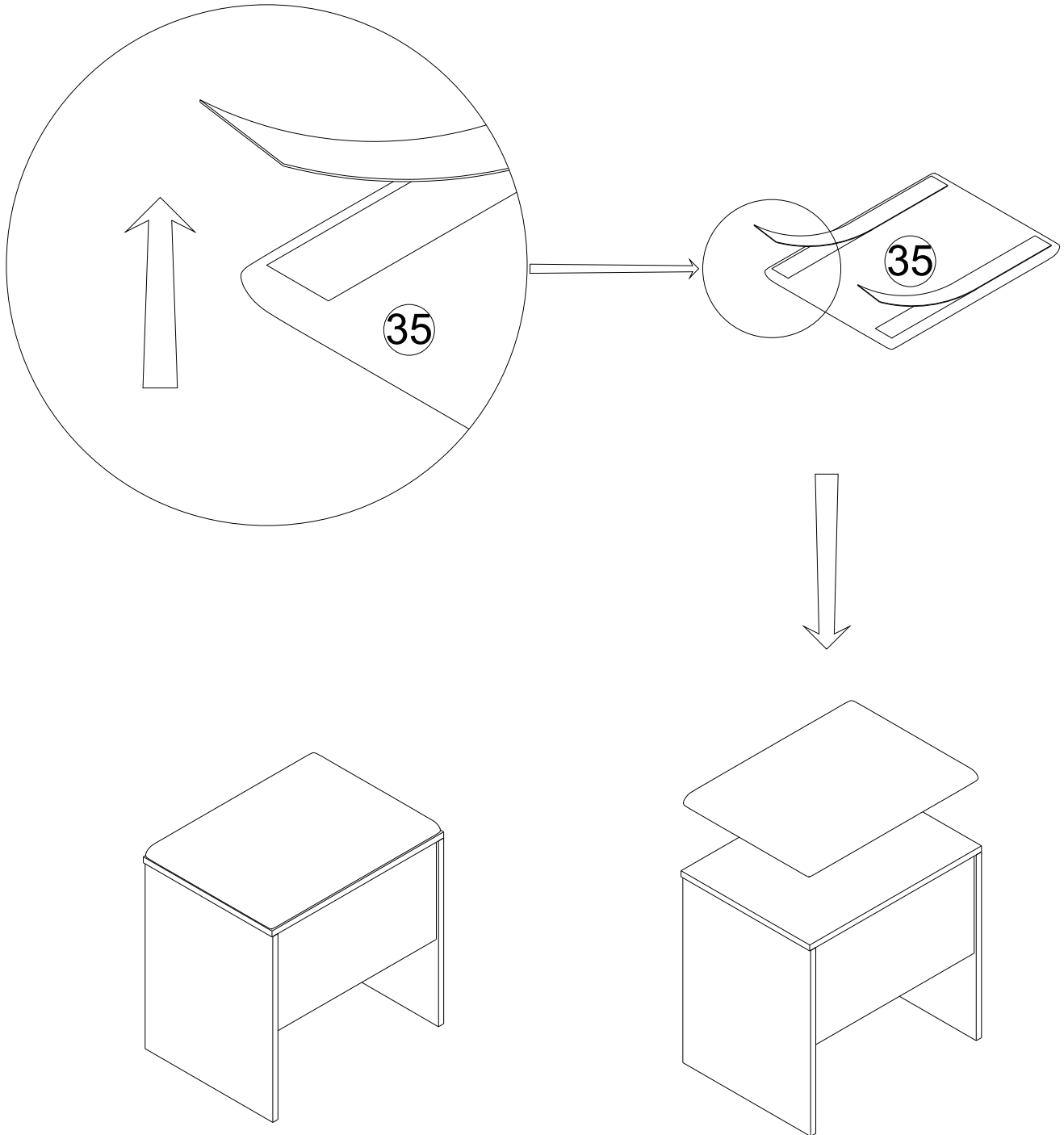

ASSEMBLY INSTRUCTION

STEP 39

