

# Owner Manual

## Desk

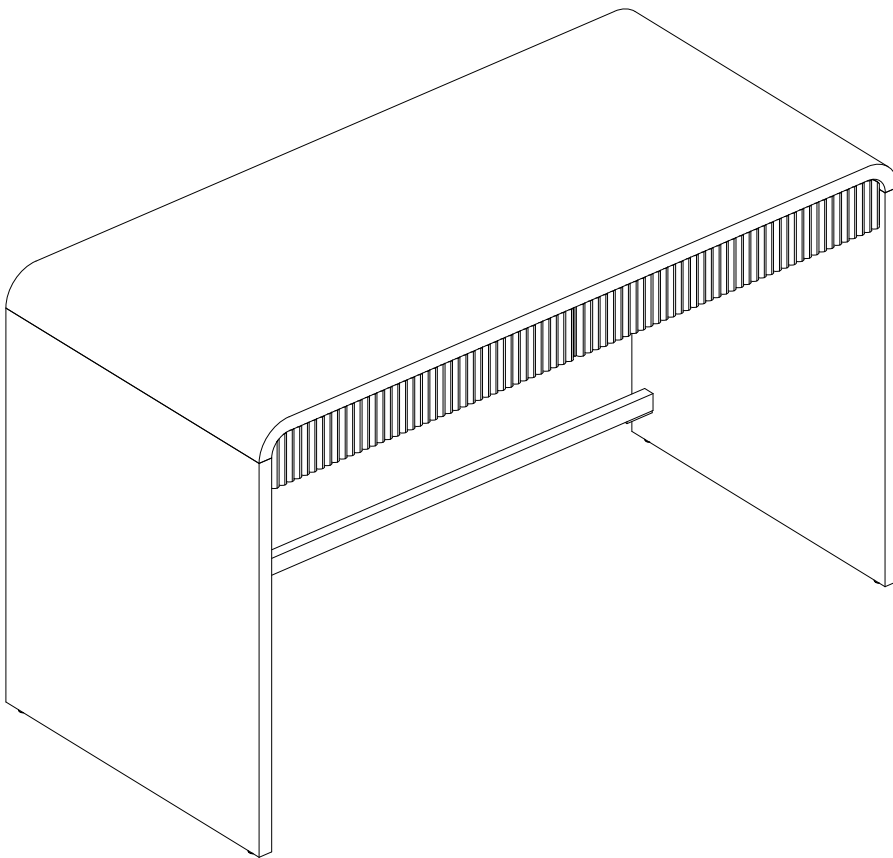

# MAINTENANCE AND WARNINGS

*Thank you for purchasing the Desk.*

*Please read the instructions and warnings carefully before use, to ensure safe and satisfactory operation of this product.*



## Before You Start

*Please follow the steps below:*

- ⚠ Unbox the package and check if all parts and accessories are complete.
- ⚠ If you find something missing, stop installing and contact your supplier immediately.
- ⚠ Please do not completely tighten all the hardware until the entire assembly is completed! Be sure to tighten all the hardware once the assembly completed.
- ⚠ NOTE: Should be assembled on soft surface to keep balance.

### ***After-Sales Service***

- If you encounter any issues or need technical support during use, please contact our after-sales team. We offer long-term maintenance and warranty services.



## Warranty

- ⚠ We strive to our high , quality products, and we also try our best to satisfy each and every customer that orders from us with product or service as needed. We provide 30 days warranty starting from the time you receive the item. Each customer must provide a record of their order such as the order number, or item receipt for any items that are out of the warranty period you may also still receive replacement parts by purchasing them with our company if they are available.
- ⚠ Are you having difficulty with assembly? Missing parts?
- ⚠ For return, please check the return policy with the retailer or market place you bought from. Appreciate your purchasing from us. Pop up your life by our furniture piece!

### ***Daily Maintenance***

- Keep furniture away from heat.
- Do not clean furniture with harsh cleansers or polish. Do not use detergents, Solvents, abrasives. spray packs or leather cleaner. Use non-color mild soap with warm water clean spills(Mix 1:10 soap to water)
- Do not place furniture under direct sunlight, material will possibly fade over time.
- Do not use on site dry Cleaning machine.
- Children should not climb or jump on the furniture.
- Do not write on furniture without a padded barrier to protect the surface.
- Not for commercial use, For residential use only.

# Exploded Diagram

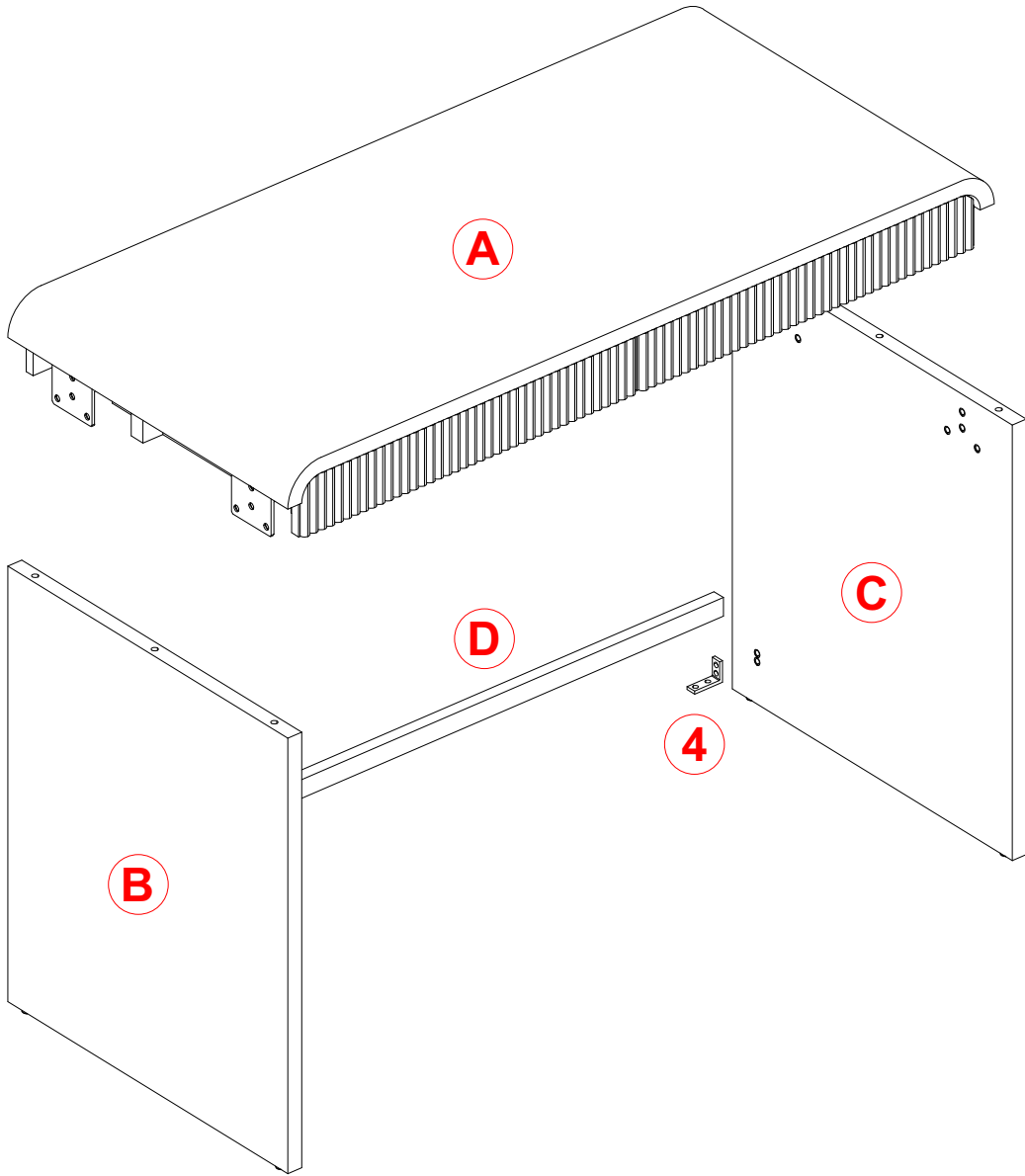

Installation:  
15 minutes.

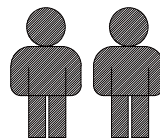

Requires 2 People  
for Assembly

## Parts List

**A** x1

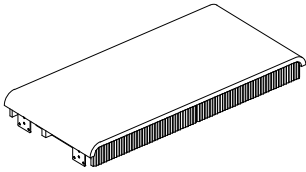

Top Panel

**B** x1

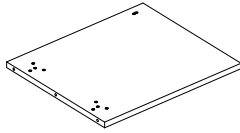

Left Side Panel

**C** x1

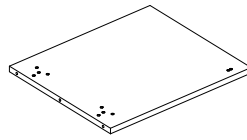

Right Side Panel

**D** x1

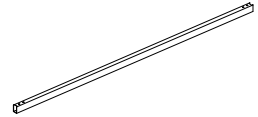

Supporting Tube

## Hardware List

**1** x 16 +1

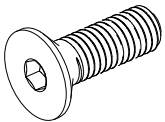

Bolt M8x20mm

**2** x 8 +1

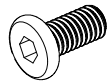

Bolt M6x16mm

**3** x 4 +1

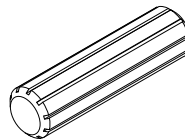

Wood Dowel 10x40mm

**4** x 2

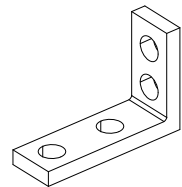

L Connect Bracket

**5** x 1

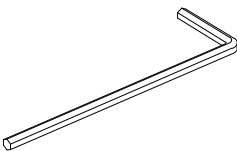

Allen Key M4

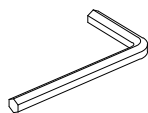

**6** x 1



Allen Key M5

# ASSEMBLY INSTRUCTIONS

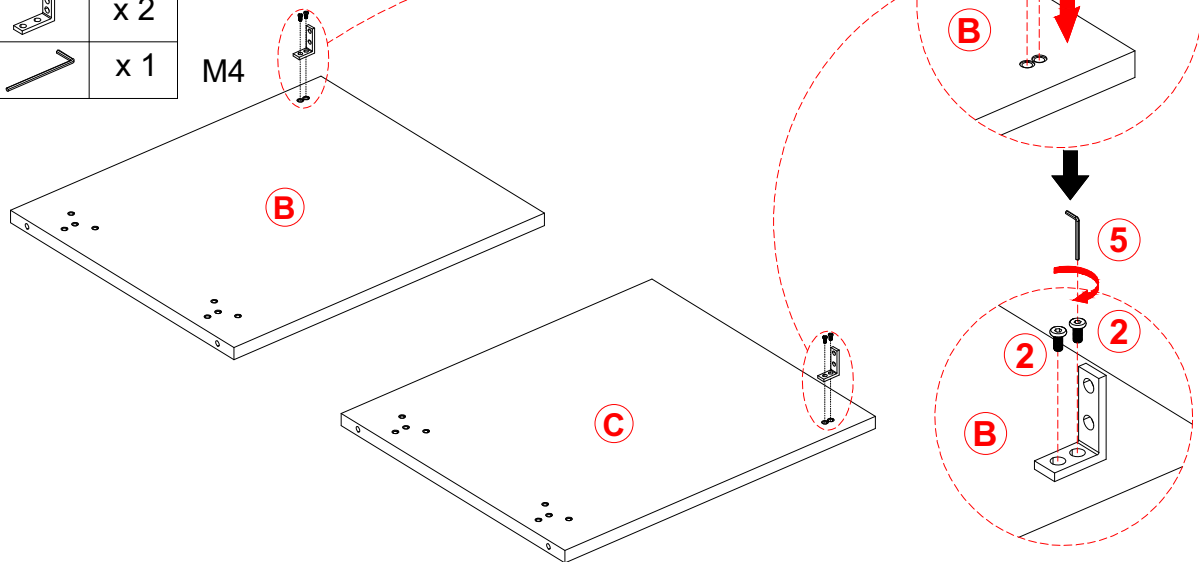

## Step 1

2		x 4
4		x 2
5		x 1



Install L connect bracket (4) onto side panel (B) & (C) using bolt (2) and fully tighten the bolt with Allen key(5).

## Step 2

1		x 16
3		x 4
6		x 1

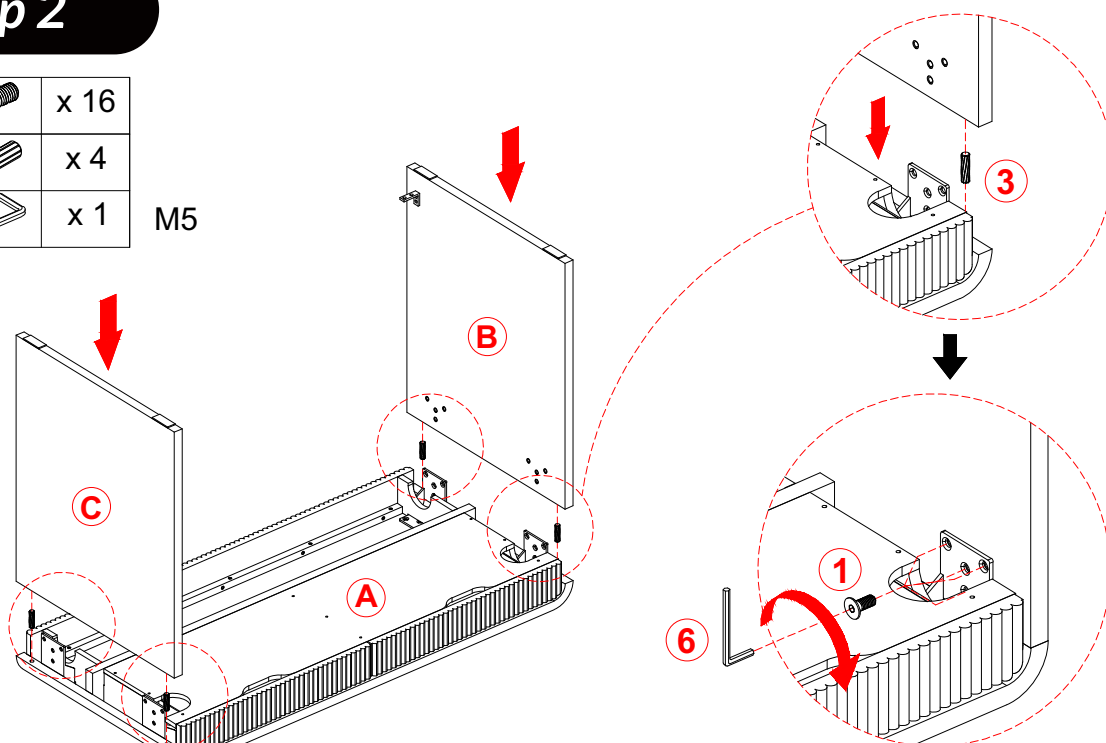

Tighten bolts (1) 70%

First insert wooden dowel (3) into side panel (B) & (C), Then connect side panel (B) & (C) to top panel (A). Install L connect bracket onto side panel (B) & (C) using bolt (1) and the bolt with Allen key(6) to approximately 70%.

## Step 3

2  x 4

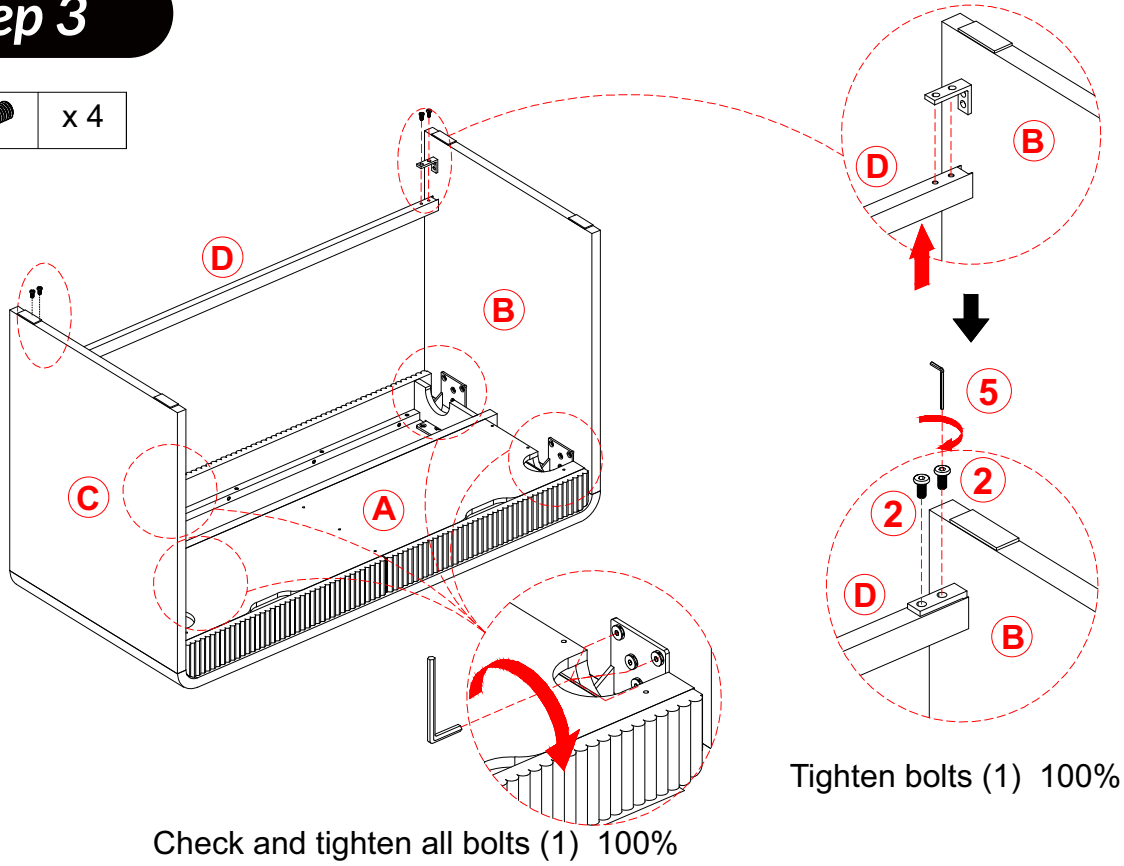

Check and tighten all bolts (1) 100%

Tighten bolts (1) 100%

Install L connect bracket (4) onto supporting tube (D) using bolt (2) and fully tighten the bolt with Allen key(5) 100%.

## Step 4

