









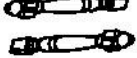

ASSEMBLY INSTRUCTION

A Table Top  1pc	B Front Leg L&R  2pcs	C Back Leg  2pcs	D Side Stretcher (Short)  2pcs
E Rear Stretcher (Long)  1pc	F Jcbc Bolt M8x60mm  8pcs	G Lock Washer M8  8pcs	H Flat Washer M8  8pcs
I Allen Key M5x60mm  1pc	J Csk-Screw M4x38mm  6pcs		



This page lists all the contents included in the box. Please take the time to identify the hardware as well as the individual components to this product. As you unpack and prepare for assembly, place the contents on a carpeted or padded area to protect them from damage.

- 1** Put the Table Top (A) upside down on the soft and smooth surface. Attach Back Leg (C) onto Table Top (A). Then insert Jcbc Bolt (F), Lock Washer (G) and Flat Washer (H) into holes of each corner block of Table Top (A) by using Allen Key (I). Do not fully tighten the bolts in this step.

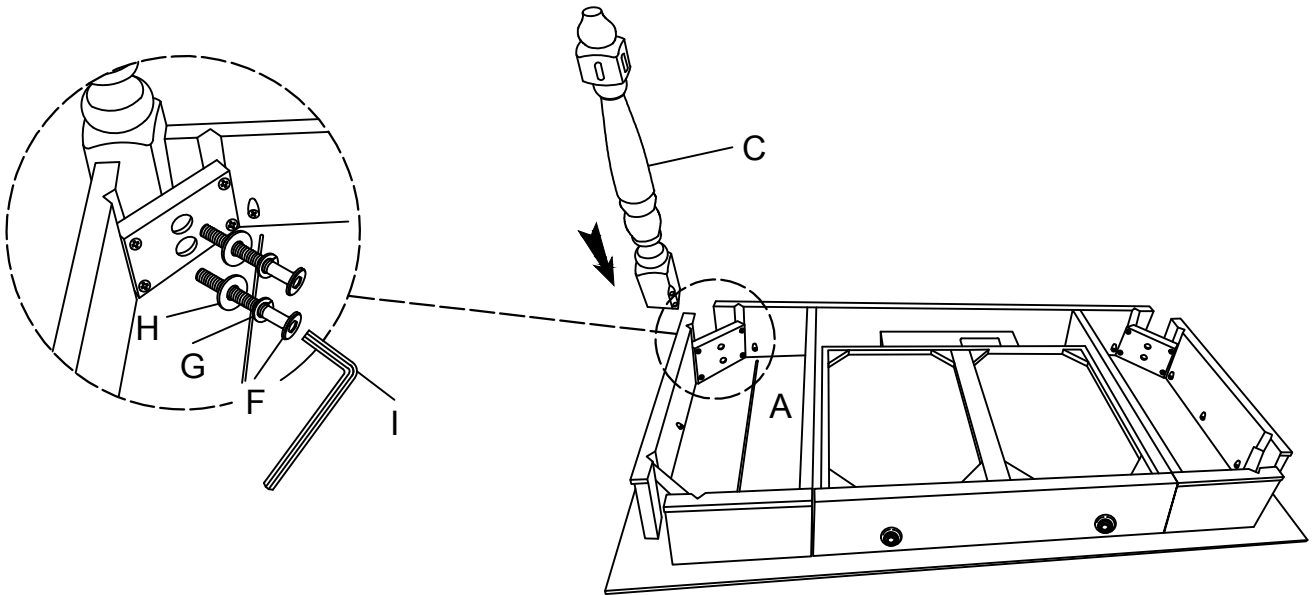

Take the Allen Key, and turn the bolts until the legs are secured.
DO NOT TIGHTEN COMPLETELY.
Stop when you feel you are adding force to tighten the bolt.

- 2** Insert Rear Stretcher (Long) (E) into Back Leg (C) with Csk-Screw (J) by using Screwdriver (not included). Attach the other Back Leg (C) onto Table Top (A). Then insert Jcbc Bolt (F), Lock Washer (G) and Flat Washer (H) into holes of each corner block of Table Top (A) by using Allen Key (I). Do not fully tighten all screws in this step.

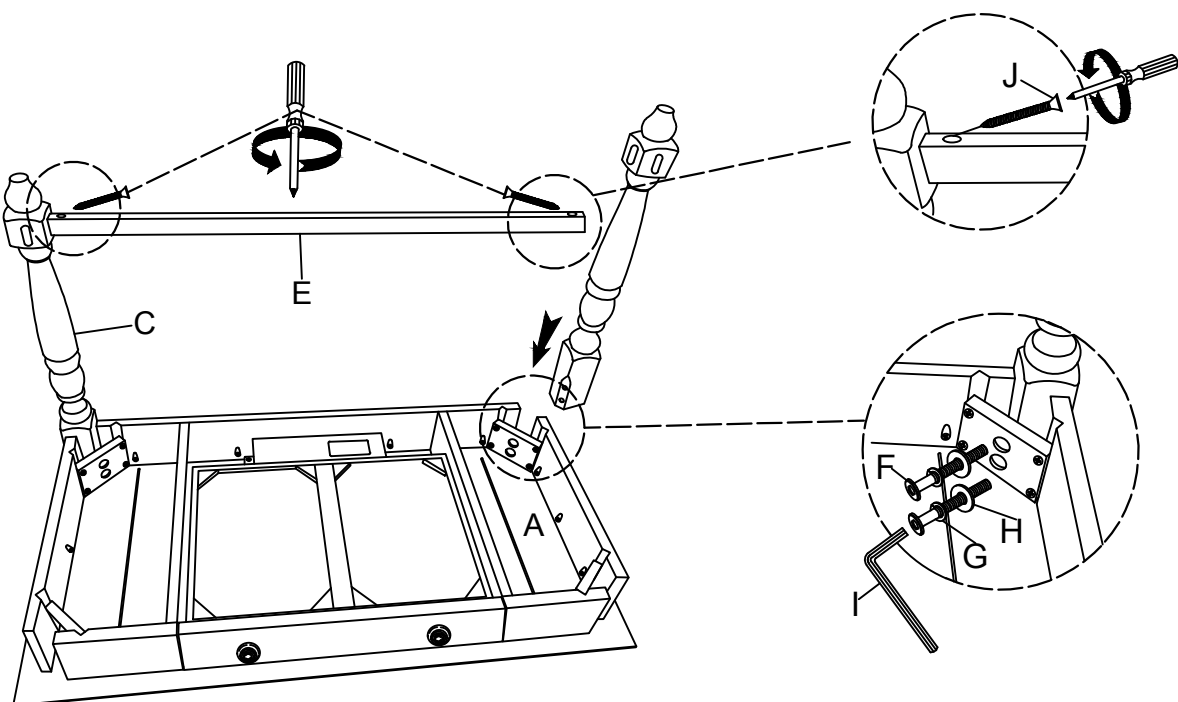

3

Insert Side Stretcher (Short) (D) into the holes of Back Leg (C) with Csk-Screw (J) by using Screwdriver (not included).

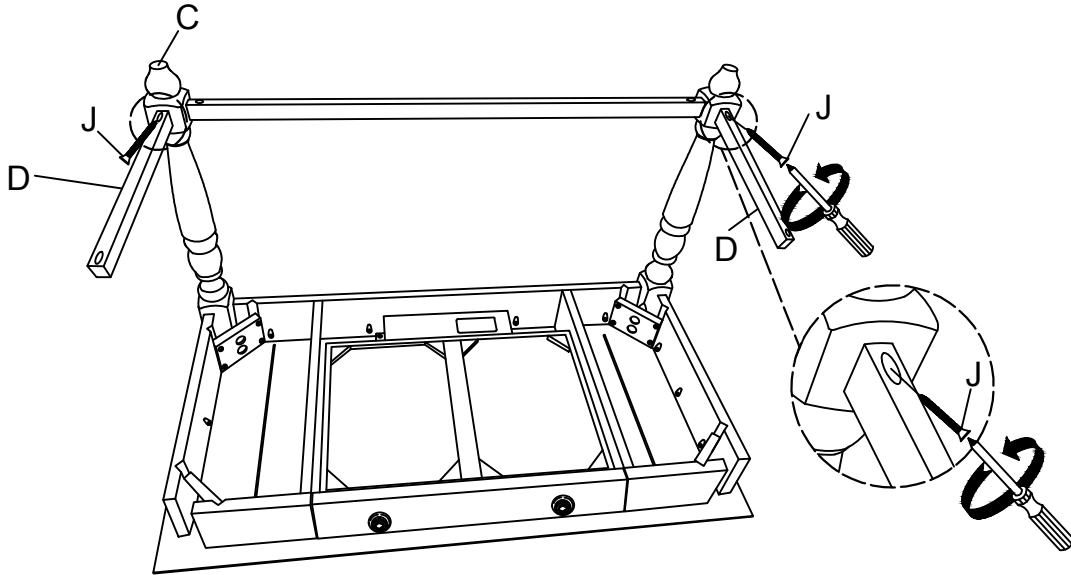
**4**

Insert Side Stretcher (Short) (D) into Front Leg (B) with Csk-Screw (J) by using Screwdriver (not included). Attach the other Front Leg (B) onto Table Top (A). Then insert Jcbc Bolt (F), Lock Washer (G) and Flat Washer (H) into holes of each corner block of Table Top (A) by using Allen Key (I). Do not fully tighten all screws in this step.

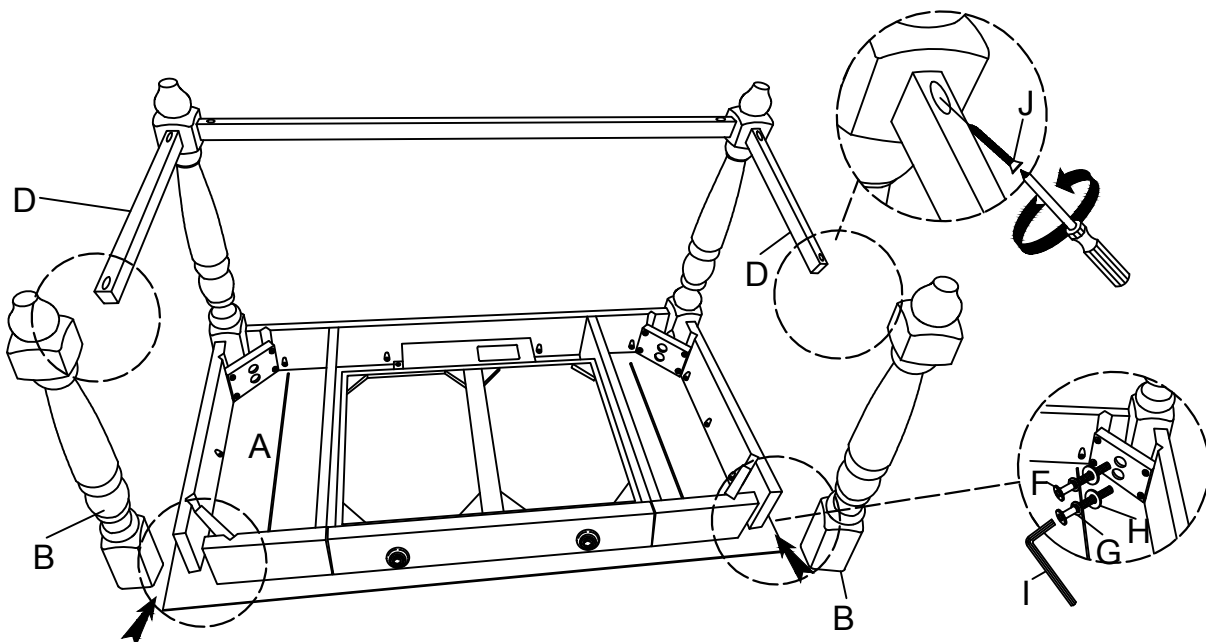

5

Turn the assembled Table to the upright position carefully. Make sure the Table is level, and then securely tighten all bolts at this stage. Assembly is now completed.

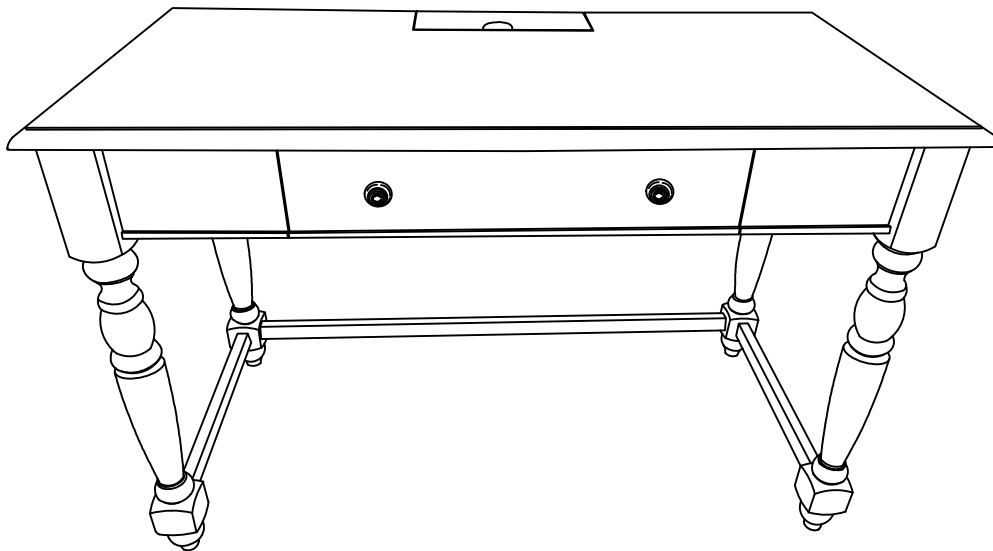

Stand Table up on an even surface and check that it is balanced. If there is a slight wobble, apply downward pressure in the corner where a leg is uneven. Keeping pressure in that corner, tighten all bolts. If balanced, apply downward pressure evenly in the center and tighten all bolts. Do not over-tighten beyond hole depth.

Cleaning & Care

Treat surface with care. Surface is resistant to scratches but is not scratch resistant. Clean surface with a dry or damp soft cloth. Do not use abrasive cleaners. Hardware may loosen over time. Periodically check that all connections are tight.