

Parts and Damage Replacement Procedure

1. Please inspect your purchase immediately.
2. This procedure covers product purchased from an authorized Roundhill Reseller and was received in its originally sealed carton.
3. If you find a part missing or damaged, you have a 30-day window in which to order a replacement part from the date on your purchase receipt.
4. You have 3 ways to do this. You will need a copy of your purchase receipt.
 - a. By Fax: Fax the parts order form below and along with your receipt to 614-878-7918
 - b. By Email: Email the order form and along with your receipt
 - c. By Mail: Fill out the parts order form below and along with a copy of your receipt send it to Roundhill furniture parts department 3640 Zane Trace Drive, Columbus OH 43228
5. Once this order is sent in, you will be notified if the part(s) you are requesting can or cannot be shipped within 7-10 business days.

**A COPY OF YOUR PURCHASE RECEIPT OR INVOICE MUST BE ATTACHED TO THIS ORDER FORM.
NO ORDERS WILL BE PROCESSED WITHOUT PROOF OF PURCHASE.**

NAME: _____
 ADDRESS: _____ (No Post Office Boxes)
 CITY: _____ STATE: _____ ZIP: _____
 PHONE: _____ FAX: _____
 EMAIL: _____

REASON FOR REPLACEMENT/PLEASE CHECK APPROPRIATE BOX.

- () Damaged /scratched, cracked, broken, crushed, etc.
- () Mechanical malfunction/ drawer glides, swivel mechanisms, lid stays, etc.
- () Missing pieces
- () Unfinished surface
- () Wrong color
- () Other

IF MORE THAN ONE MODEL NUMBER IS LISTED ABOVE, PLEASE SPECIFY THE EXACT MODEL NUMBER OF YOUR ITEM IN THE SPACE PROVIDED BELOW.

Model Number	Part Letter Code	Quantity

ASSEMBLY INSTRUCTIONS





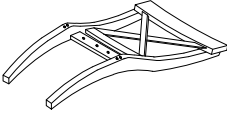
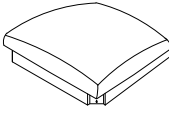
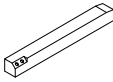

DESCRIPTION : SIDE CHAIR

Thank you for purchasing this quality product. Be sure to check all packing material carefully for small Hardware which may have some loose inside the carton during shipment. Identify and count all Hardware. Identify and all Hardware and compare with the Hardware List Below.

"PART LISTS"

STT	DESC	OUTLOOK	Q'TY
1	CHAIR BACK		1pc
2	SEAT FRAME		1pc
3	CHAIR LEGS		2pcs

"HARDWARE LISTS"

STT	OUTLOOK	SIZE	Q'TY
A		5/16"x75mm BOLT	4pcs
B		5/16"x60mm BOLT	4pcs
C		5/16"x38mm BOLT	2pcs
D		5/16" SPRING WASHER	10pcs
E		5/16"x19mm LOCK WASHER	10pcs
F		4mm ALLEN WRENCH	1pc
G		Ø10x30mm DOWEL	1pc

ASSEMBLY INSTRUCTIONS

DESCRIPTION : SIDE CHAIR

