

ASSEMBLY INSTRUCTIONS

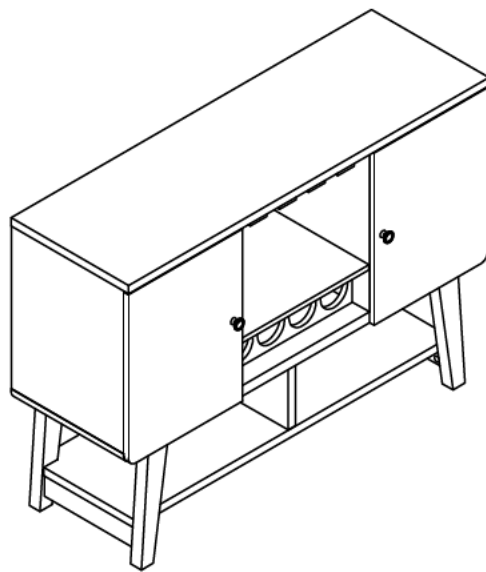



ASSEMBLY RATING

The Assembly Rating is a 5-point system that shows the degree of effort needed in assembling a specific product (with 1 being easy and 5 being difficult). For most products, two persons are recommended.

EASY  DIFFICULT

Tools Required for Assembly:

Phillips Screwdriver 
(Not Included)

Phillips Screwdriver
1 1/2" L 
(Not Included)

Hammer 
(Not Included)



2 PERSONS RECOMMENDED

ASSEMBLY & CARE ADVICE

FOR YOUR FURNITURE TO LAST, CORRECT ASSEMBLY AND PROPER MAINTENANCE ARE NECESSARY PLEASE FOLLOW THE INFORMATION PROVIDED BELOW TO FULLY ENJOY YOUR FURNITURE.

BASIC ASSEMBLY TECHNIQUES



It is highly recommended that the assembly should be done near the area of its intended location. Make sure you have enough space to move around during the assembly.

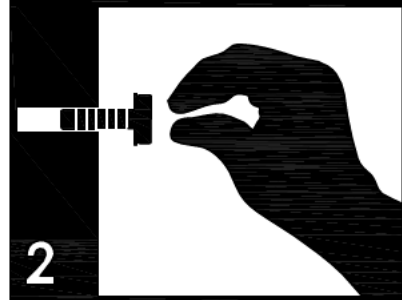

Position each part correctly and insert screws or bolts into their respective holes by hand tighten or using the proper hand tool. Only tighten when step is completed or when instructed to do so.

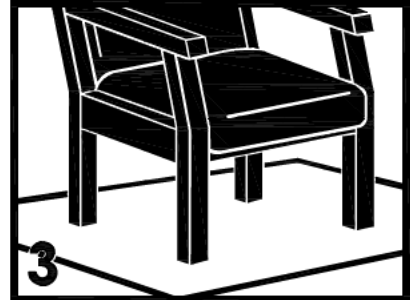

Use cardboard or carpet area when assembling furniture to prevent scratches. Make sure the furniture rests on a flat and level surface with each leg evenly touching the floor.

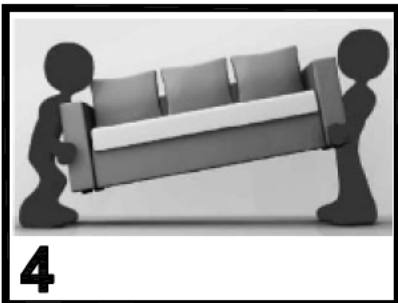

ALWAYS have at least two people to help with transporting and assembling the product to avoid any potential injury and/or damage.

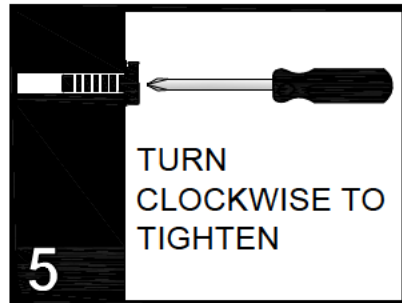

Make sure all parts are properly aligned, then use the appropriate hand tool to completely tighten the bolts or screws. Do not use power tools and do not overtighten.



Save the instructions and store any supplied tool for later maintenance. After two weeks, check and tighten any loose hardware and repeat again every six months thereafter.

IT IS THE USER'S RESPONSIBILITY TO MAINTAIN THE FURNITURE. THE HARDWARE MAY LOOSEN OVER TIME AND MAY CAUSE THE FURNITURE TO BE WOBBLY AND UNABLE TO SUPPORT ITS INTENDED WEIGHT CAPACITY. THIS MAY LEAD TO COLLAPSE AND MAY CAUSE SERIOUS INJURY.



FAILURE TO FOLLOW THE GUIDELINES ABOVE MAY RESULT IN INJURY AND/OR PROPERTY DAMAGE.

PRE-ASSEMBLY INTRODUCTION

Unless you are particularly adept at assembling flat-pack/knock-down furniture, we understand building ready-to-assemble furniture can be a frustrating experience for some. To help avoid confusion and to make the assembly process quicker and smoother, we have provided some helpful tips. Before you begin the assembly, please read the following :

1. Due to the size and/or weight on most of the ready-to-assemble furniture, it is highly recommended that the assembly should be done near the area of its intended location. Make sure you have enough space to move around during the assembly. ALWAYS have at least two people to help with transporting and assembling of the product to avoid any potential injury and/or damage.
2. To protect from damage, assemble the item on a clean, protective surface, such as on a carpet or cardboard.
3. Make sure you have taken all the parts and hardware out of their packaging. Do not throw away packaging material until assembly is completed.
4. Make sure all parts and hardware are accounted for by comparing the actual parts and hardware to the list provided in the assembly instructions. Also check for any irregularity such as crack, flaw or improperly drilled hole. If there is any problem or missing piece, please contact the manufacturer or the supplier. Please have the model number, part number and a brief description of the problem ready will help expedite the replacement process.
5. Read the entire instruction manual and view the diagrams first before assembling. Arrange your parts in order of use and group the identical hardware together to make it easier to grab each piece as you begin to assemble.
6. During the assembly process, make sure parts are properly aligned before tightening with the tool provided or required for the assembly. Do not use power tools and do not over tighten.
7. When applying glue to the wood dowels to bond the parts together, please be ABSOLUTELY certain that the parts are correct and lined up with each other (refer to diagrams and take notice of the various pre-drilled hole locations). When in doubt, assemble the parts together first and if the parts fit right, then apply glue to the wood dowels.



CAMLOCK FASTENER ASSEMBLY INSTRUCTIONS

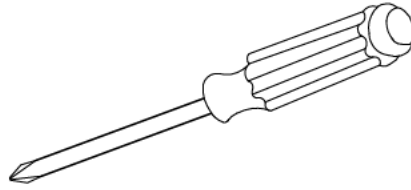
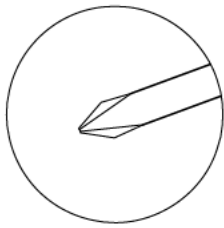

Note: Every cam lock bolt must have a cam lock connector in order to fasten the parts together.

- (1) Secure the threaded end of the cam bolt by using a screwdriver.

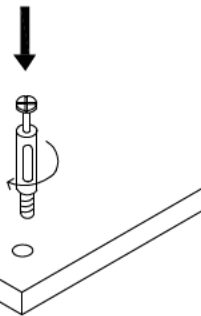

Turn right (clockwise) to tighten.

Align the cam connector with its side opening (or arrow) pointing to the small drilled hole.

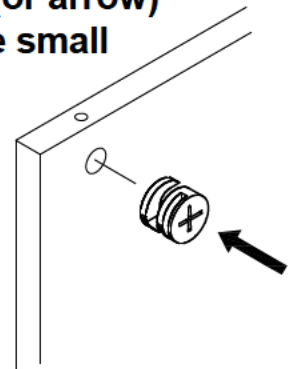

- (2) Insert the cam lock bolt into the pre-drilled hole above the cam connector.

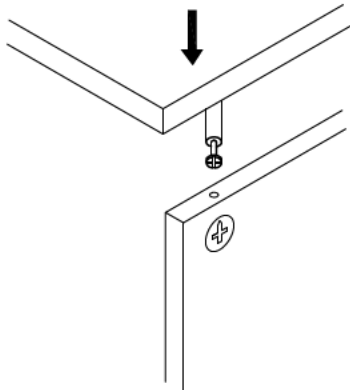

- (3) Two parts should fit snugly against each other.

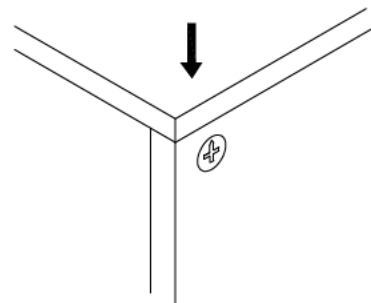

- (4) Turn right (clockwise) to tighten.

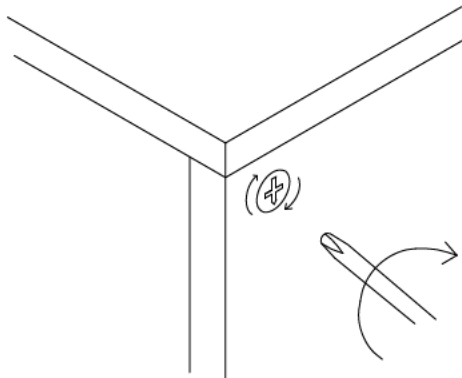

Turn the cam connector with a screwdriver until it will not turn any more with light to moderate force.



PARTS LIST

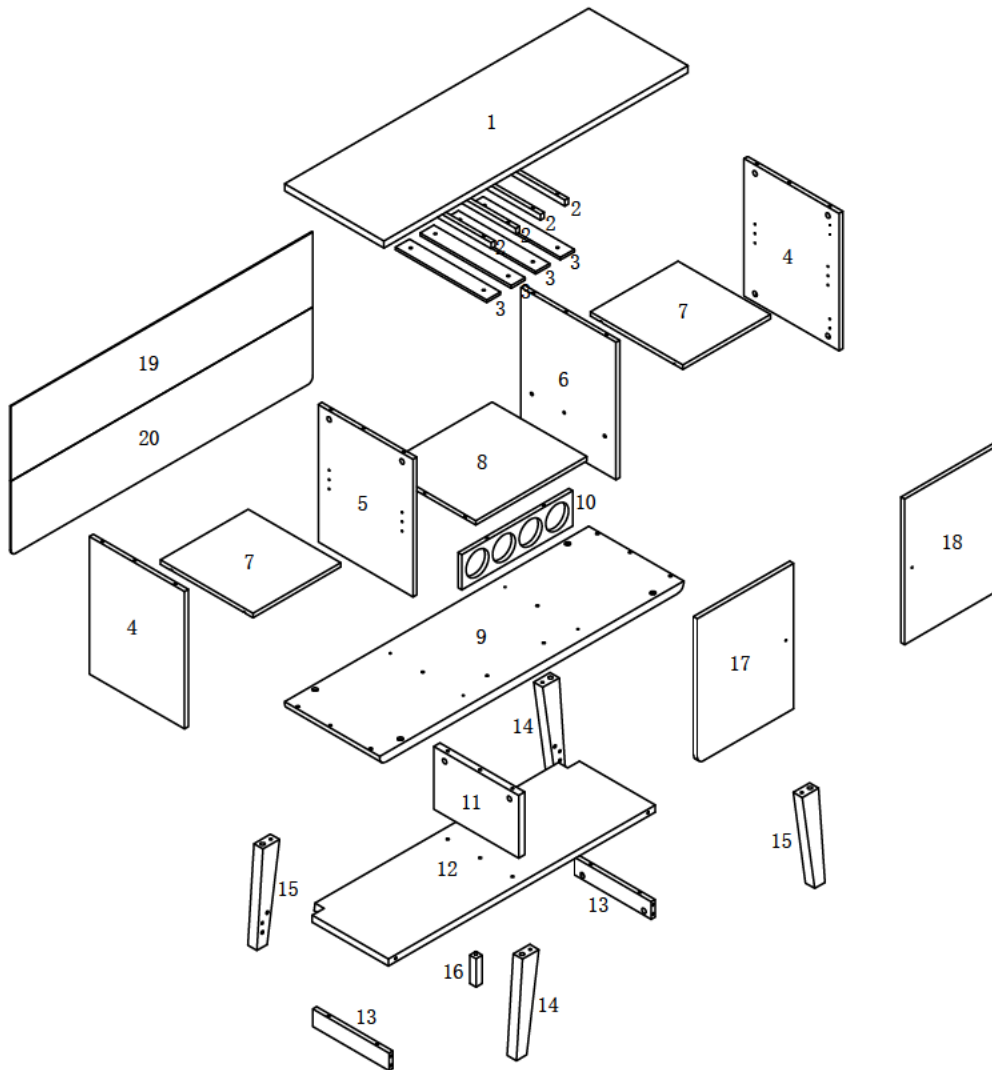























(1)	4pcs	(8)	1pc	(15)	2pcs
(2)	4pcs	(9)	1pc	(16)	1pc
(3)	1pc	(10)	1pc	(17)	1pc
(4)	2pcs	(11)	1pc	(18)	1pc
(5)	1pc	(12)	1pc	(19)	1pc
(6)	1pc	(13)	2pcs	(20)	1pc
(7)	2pcs	(14)	2pcs		

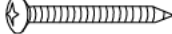

Before you begin, please read "Assembly and Care Advice", "Pre-Assembly Introduction" and "Cam Lock Fastener Assembly Instructions".

HARDWARE LIST

A		L29	26pcs
B		Ø15	26pcs
C		Ø8x25	28pcs
D		Ø22	18pcs
E		Ø4x40	4pcs
F		Ø7x58	2pcs
G		Ø8xØ16x2	6pcs
H		M8x40	4pcs
I		M5	1pc
J		Ø16	4pcs
K			40pcs
L		M6x35	8pcs
M		Ø5x15	8pcs
N		301A	4pcs
O		Ø4x16	16pcs
P			2pcs
Q		Ø4x22	2pcs
R		197x5x1	1pc
S		Ø8x40	1pc
T		12x12x1	2pcs
U		Ø5x40	1pc
V		Ø4x25	1pc
W		Glue: For securing please apply to wood dowel first before inserting into panel	1pc



Due to the size and/or weight of this product, it is highly recommended that the assembly should be done near the area of its intended location. Make sure you have enough space to move around during the assembly. ALWAYS have at least two people to help with transporting and assembling the product to avoid any potential injury and/or damage

ASSEMBLY INSTRUCTIONS

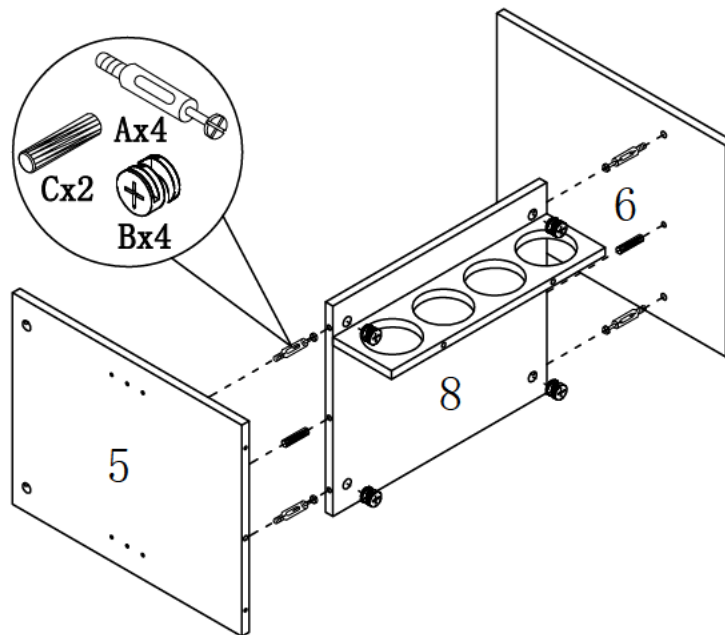
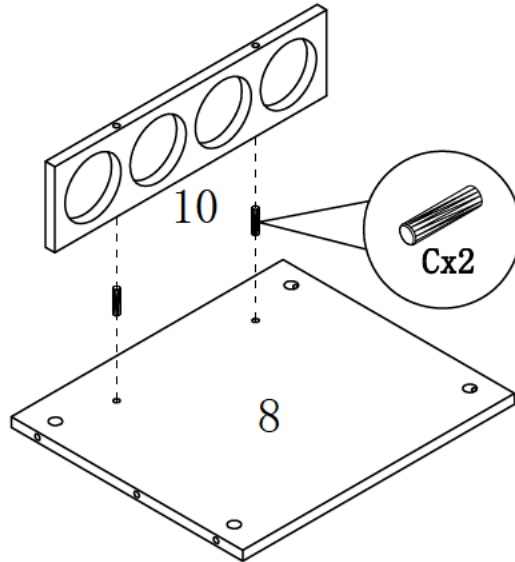

ASSEMBLY INSTRUCTIONS

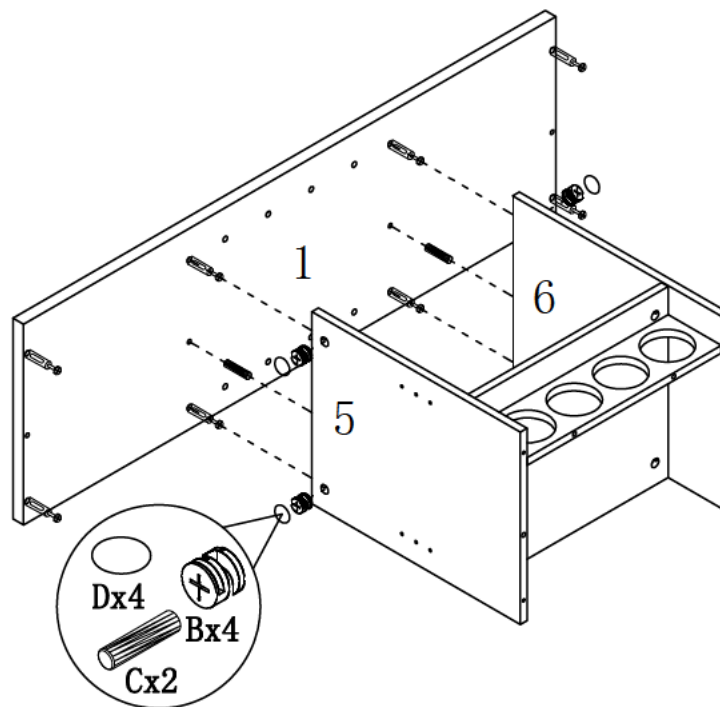
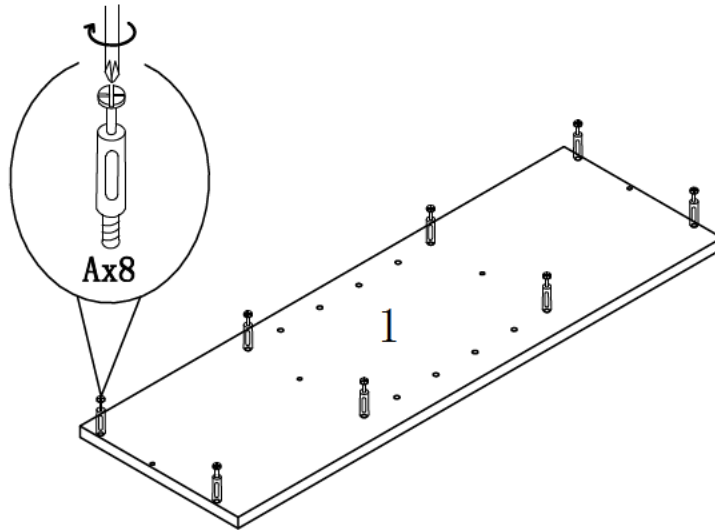

ASSEMBLY INSTRUCTIONS

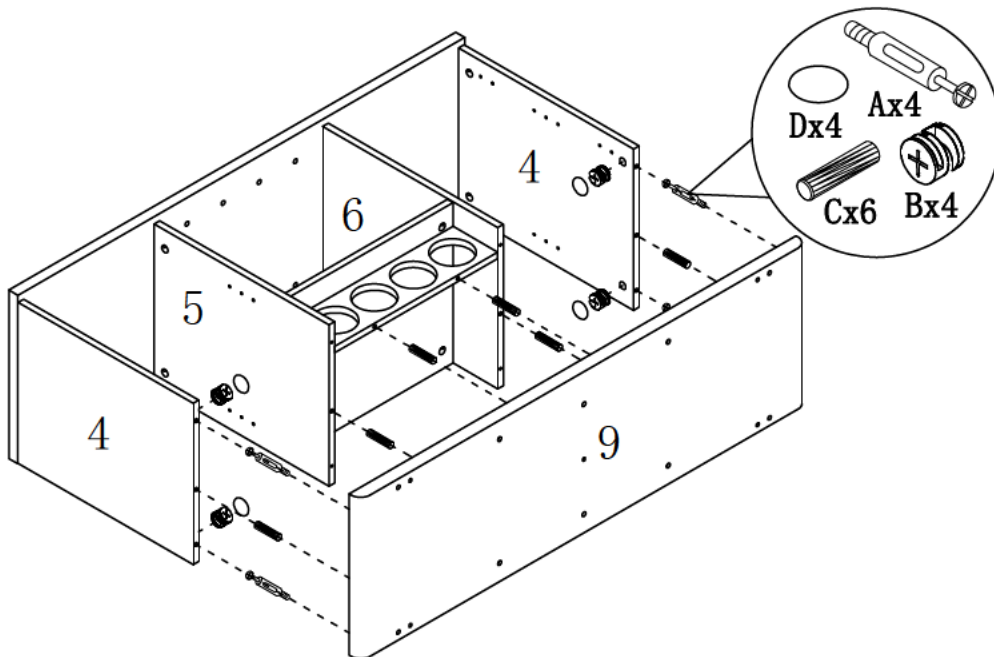
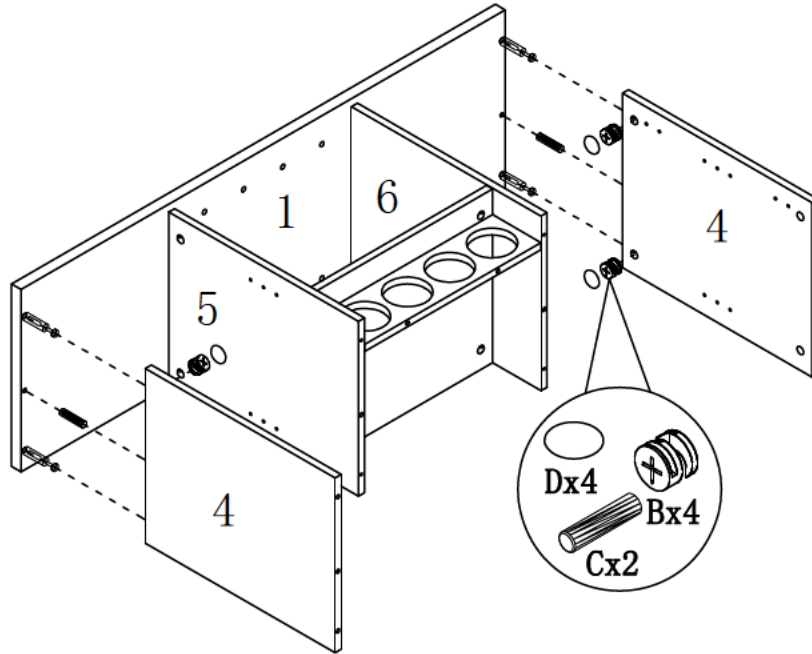

ASSEMBLY INSTRUCTIONS

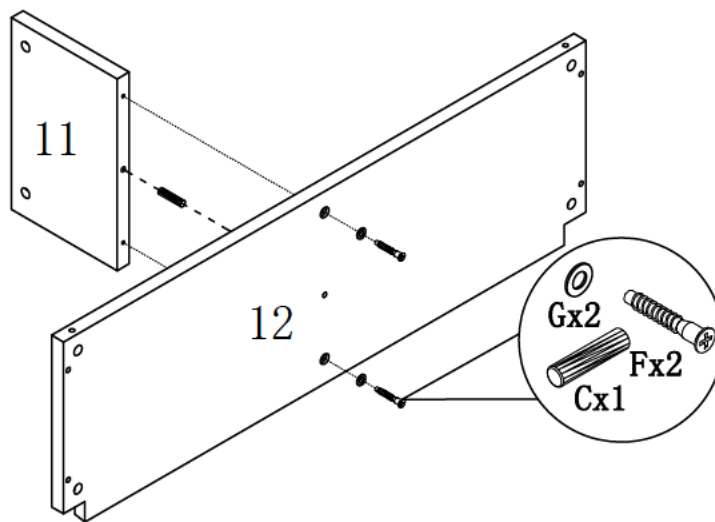
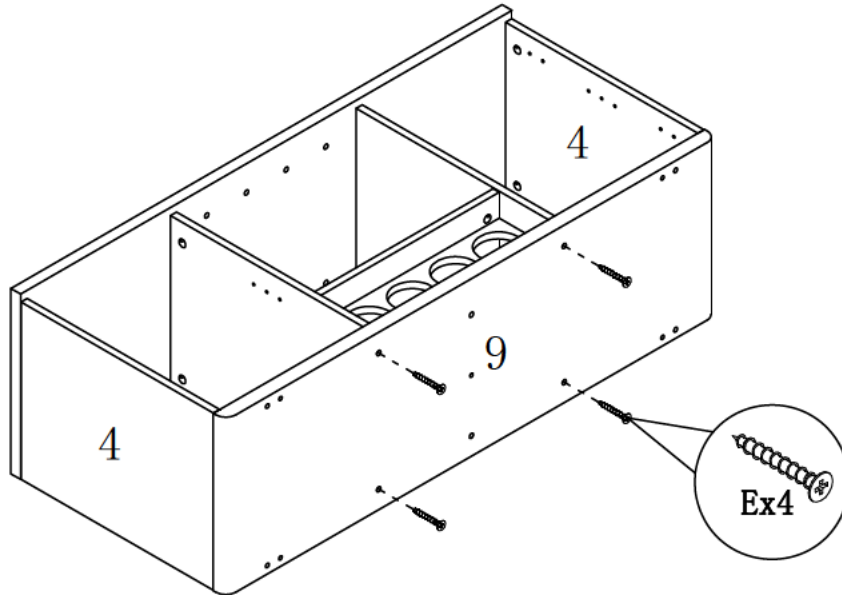

ASSEMBLY INSTRUCTIONS

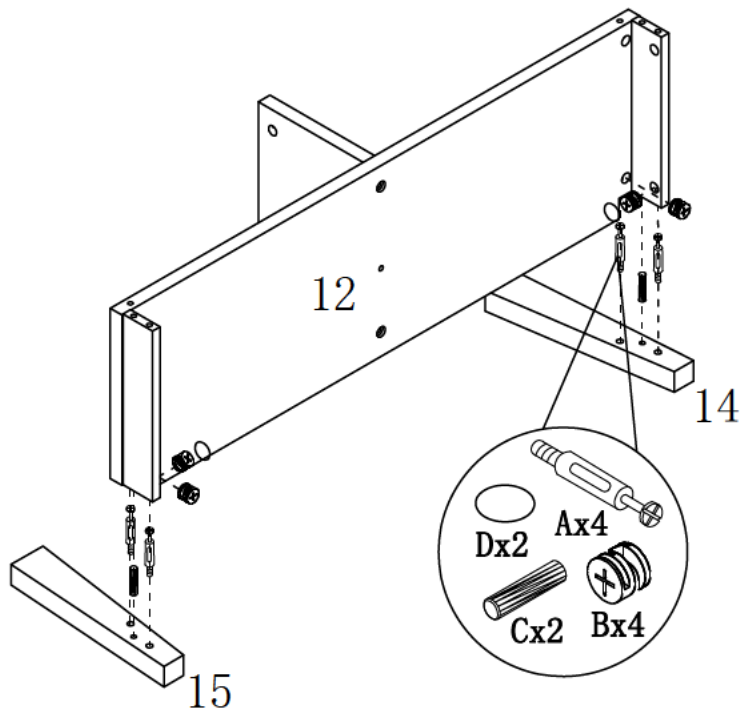
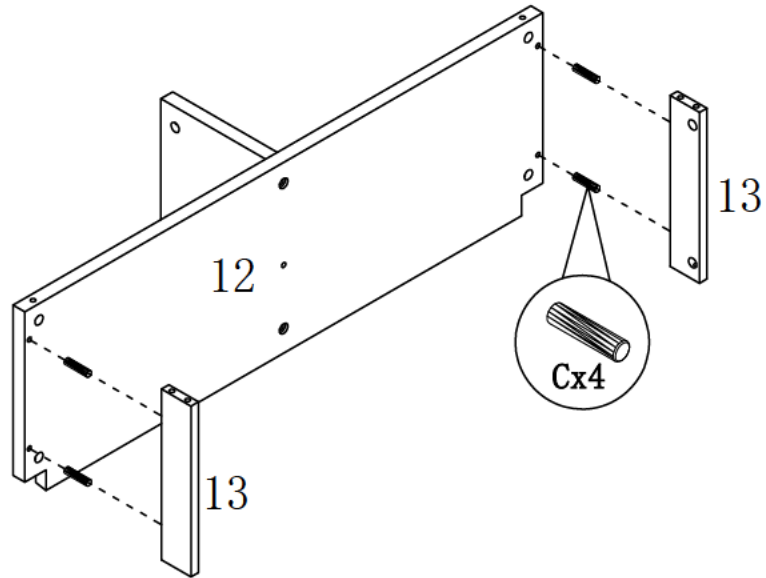

ASSEMBLY INSTRUCTIONS

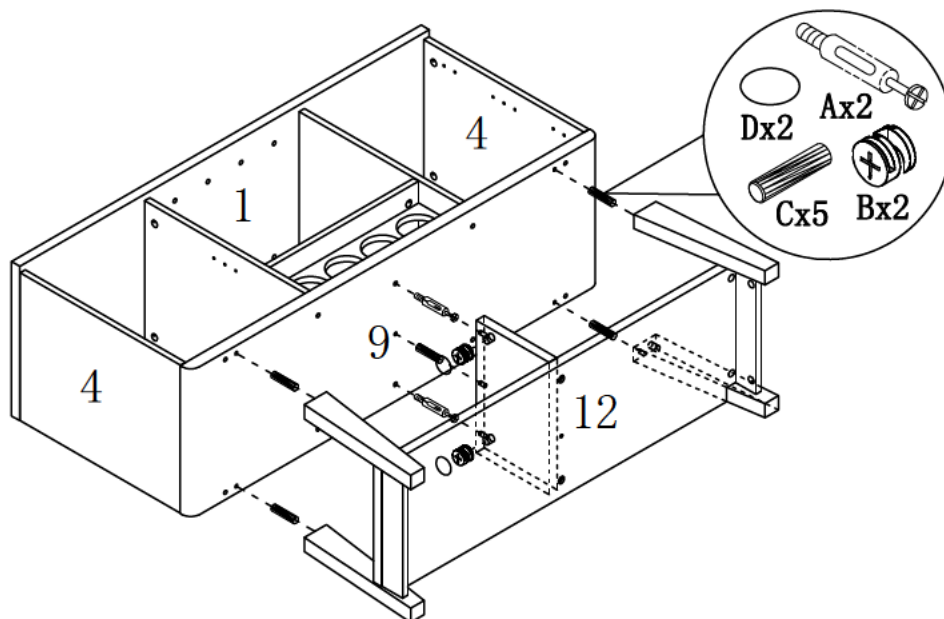
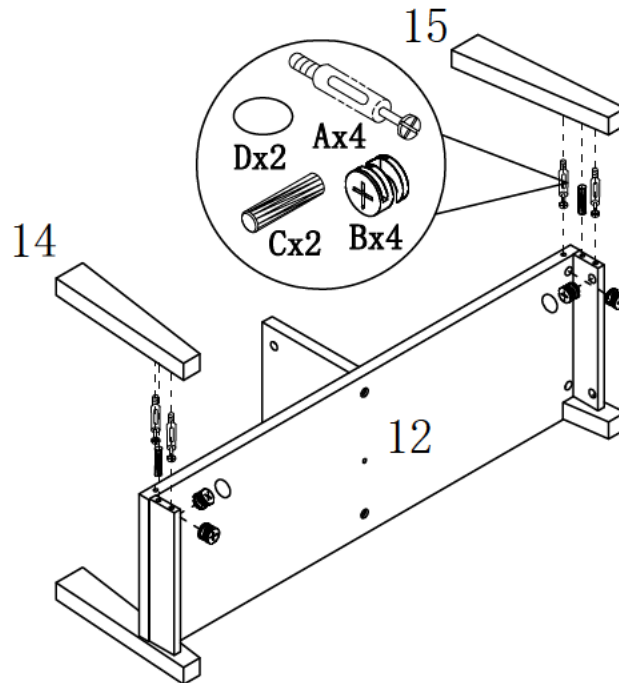

ASSEMBLY INSTRUCTIONS

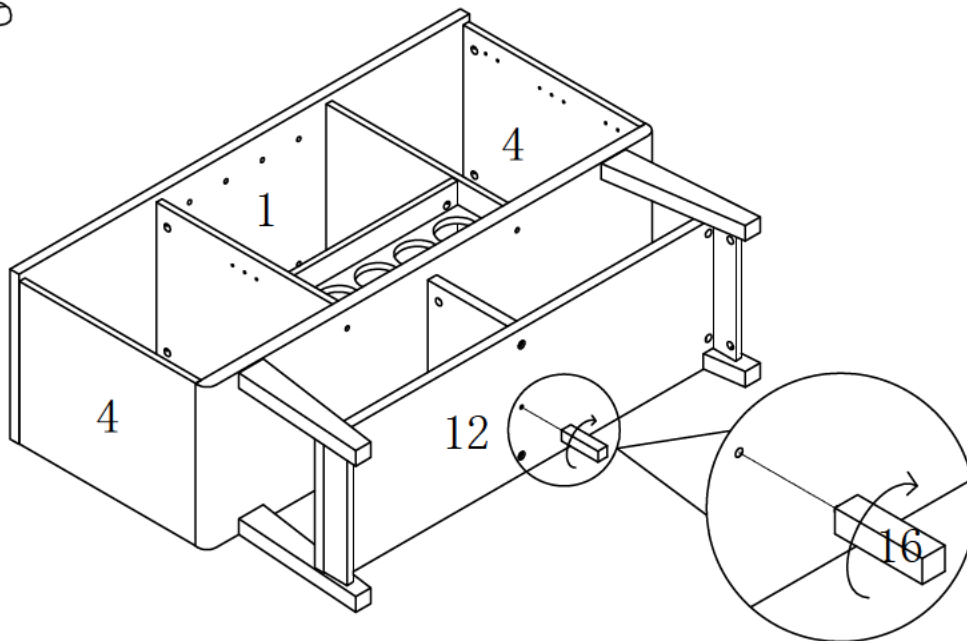
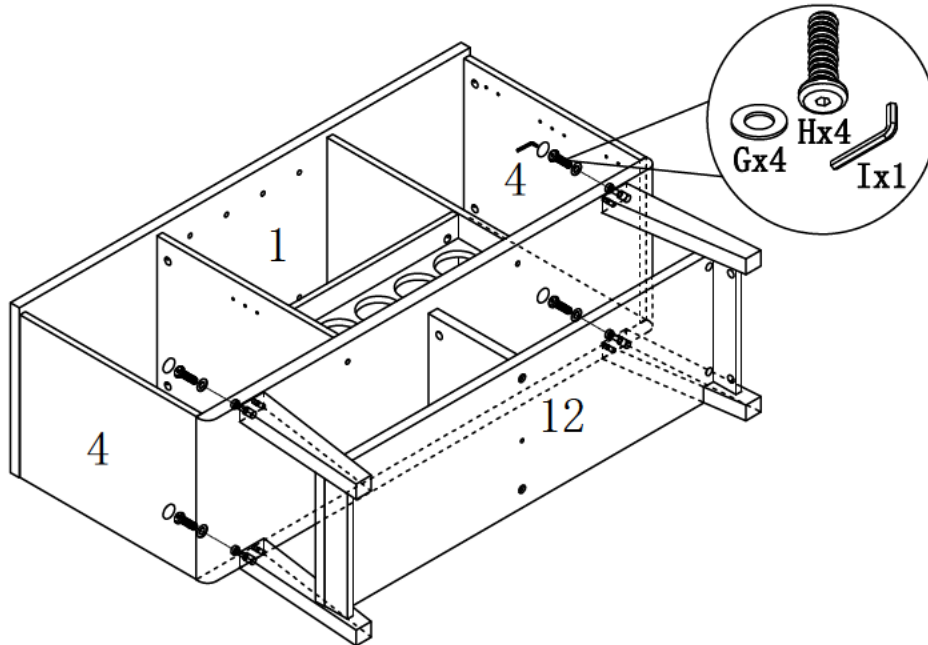

ASSEMBLY INSTRUCTIONS

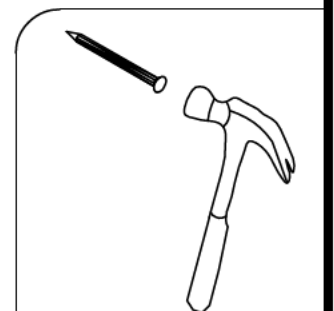
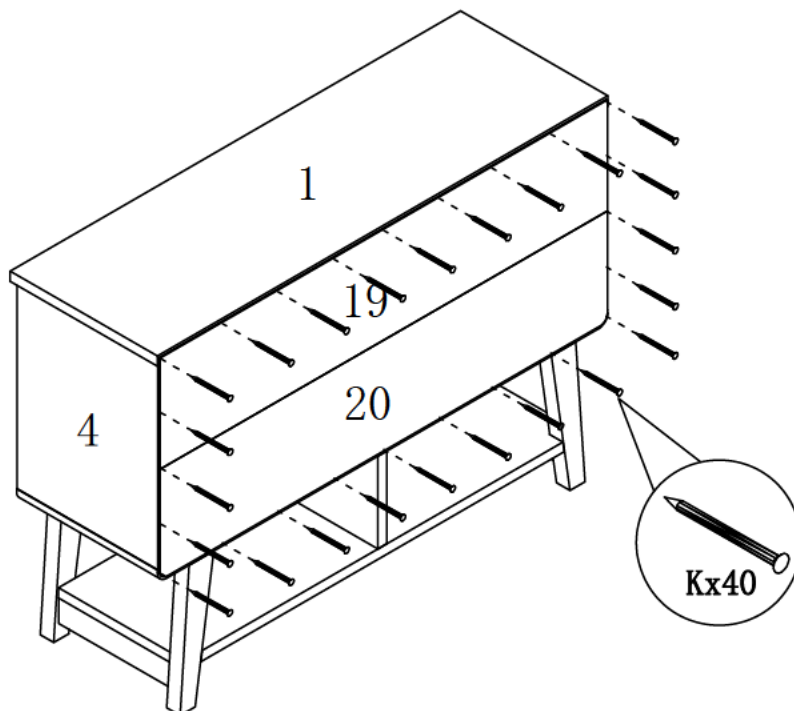
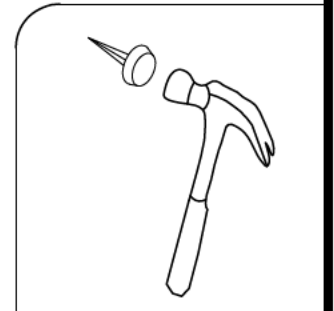
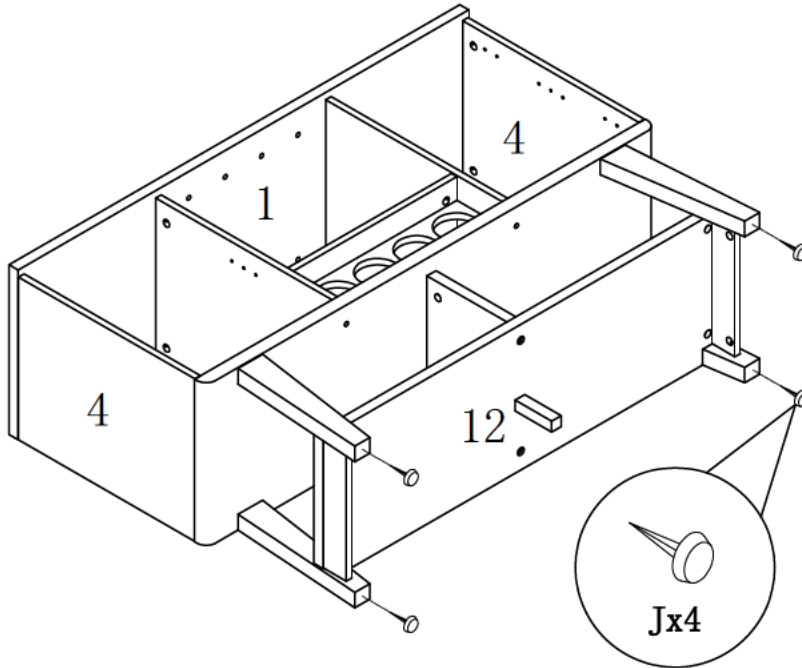

ASSEMBLY INSTRUCTIONS

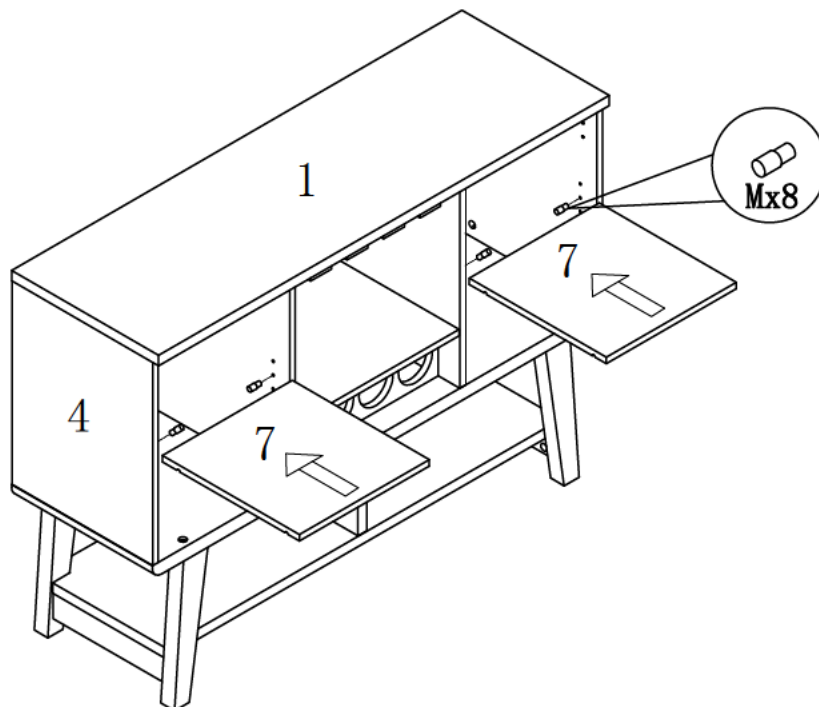
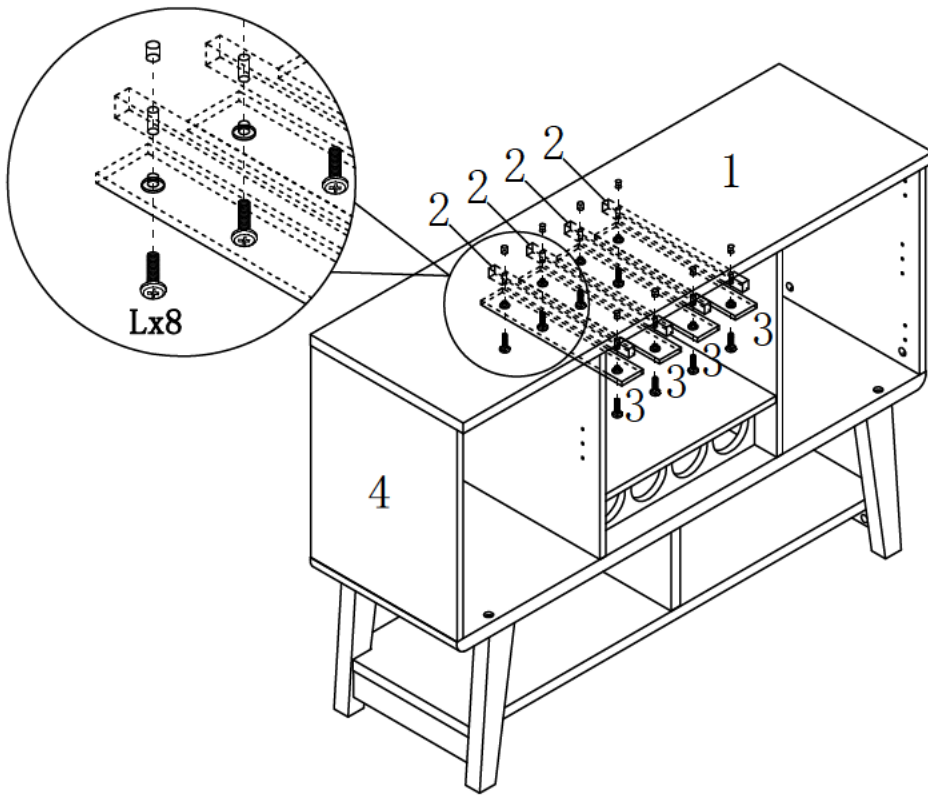

ASSEMBLY INSTRUCTIONS

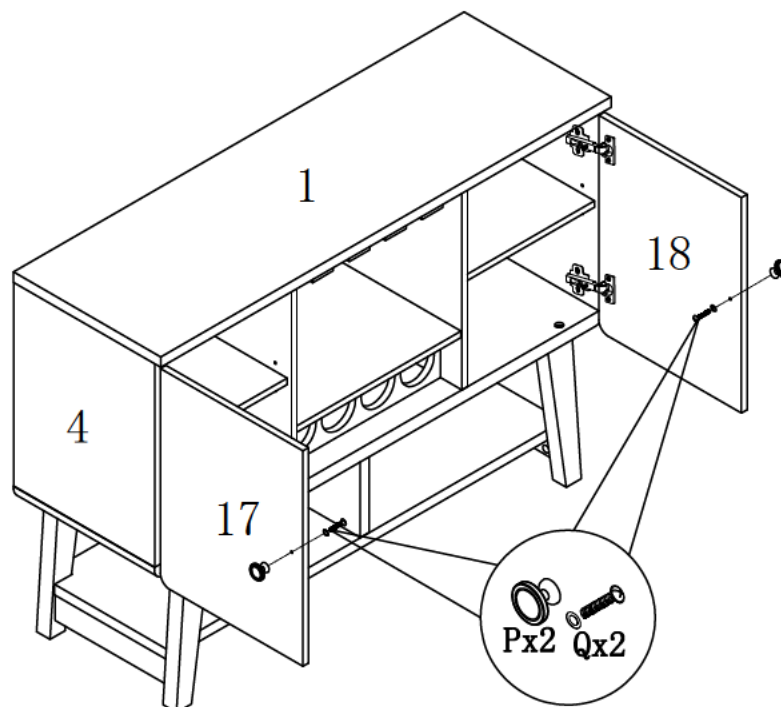
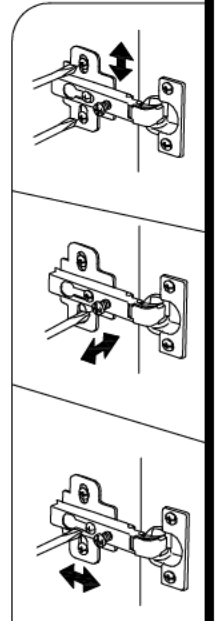
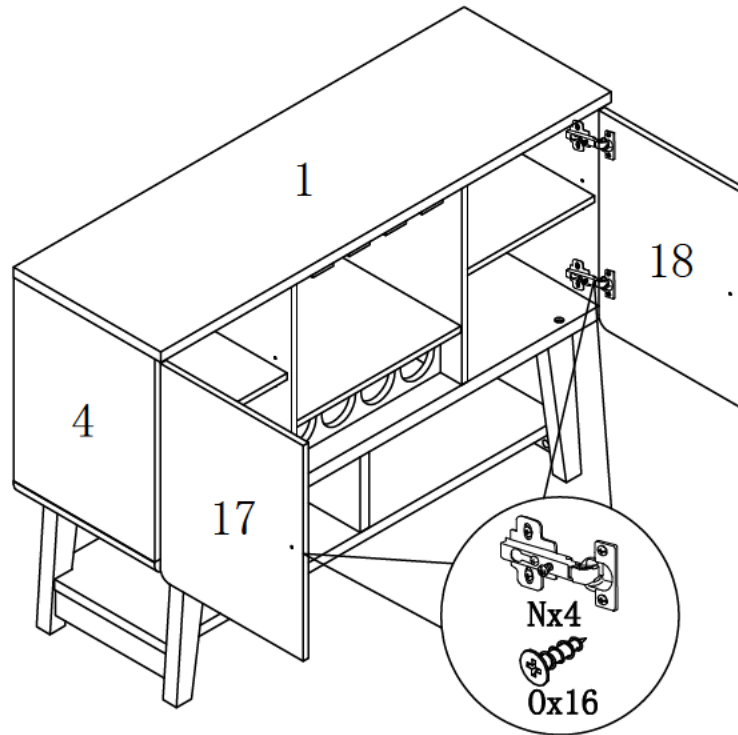

ASSEMBLY INSTRUCTIONS



SAFETY STRAP TO PREVENT TIP-OVER

SAFETY STRAP TO PREVENT TIP-OVER

Drywall: Select a location where you want the table to be mounted. Place the assembled table against the wall and, on the wall, mark the location where the anchor will be placed. Drill a hole slightly smaller than the size of the screw. Push the anchor as far as it will go with your finger. Tap gently with a hammer until the anchor is flush with the wall surface. Secure the strap using a Phillips screwdriver to tighten the screw through the strap and into the anchor. On the other end of the strap, secure it using a Phillips screwdriver to tighten the screw through the strap and into the back of the table.

If the location happens to be a wood stud, do the following:

No anchor will be needed if securing to a wood stud. Drill a hole slightly smaller than the size of the screw. Secure the strap using a Phillips screwdriver to tighten the screw through the strap and into the wall (wood stud). On the other end of the strap, secure it using a Phillips screwdriver to tighten the screw through the strap and into the back of the table.

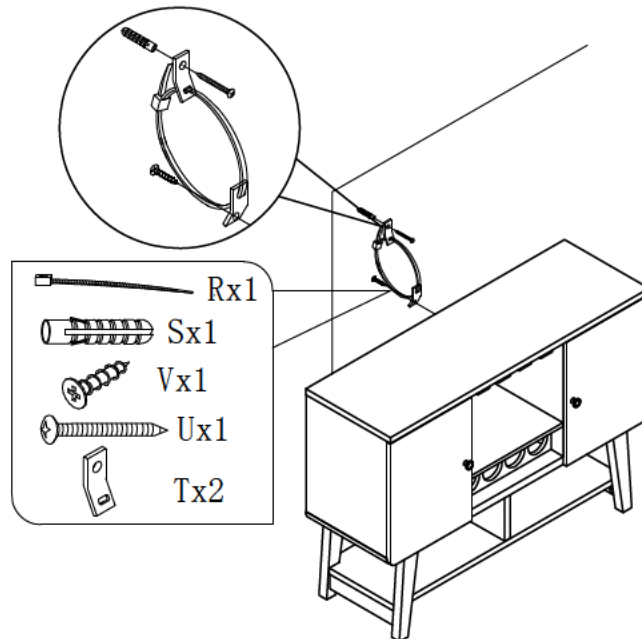

Before strapping, make sure the table is rested on a flat surface and does not feel loose or wobbly. If it does, double check that the bolts/screws are secured and properly tightened.

ASSEMBLY IS COMPLETED

HINGE ADJUSTMENT

Height Adjustment

Located at the top and bottom of the hinge are two screws that mount the hinge to the cabinet. Turn these first to make sure the door is secure. If the door is still too high or low, loosen these screws slightly and then lift or lower the door until it is in the position you want. Firmly tighten the screws to secure the door. Remember to support the door as you loosen these screws or it could drop completely out of its initial position. Close the cabinet doors to see whether the fit is satisfactory. Repeat the process if adjustment is still needed.

Depth Adjustment

The screw closest to the back of the cabinet is the depth screw and moves the doors in and out. Use this screw to adjust how far out or in the doors are in comparison to your cabinet and to the other cabinet doors and drawers surrounding it. Loosen the screw and manually PUSH or PULL the door to adjust it to the position you want. Firmly tighten the screws to secure the door. Close the cabinet doors to see whether the fit is satisfactory. Repeat the process if adjustment is still needed. If possible, avoid maxing out the adjusting screw for it may cause unwanted problems.

Side-To-Side Adjustment

The screw closest to the cabinet door allows the doors to move from side to side. Tighten this screw (clockwise) to move this corner of the door further toward the frame ; loosen it (counterclockwise) to move the door away from the frame. This adjustment can also be used to correct a door that is not hanging straight. If the top is further to the left or right than the bottom, adjust the top and bottom hinges separately to correct the tilt. Close the cabinet doors to see whether the fit is satisfactory. Repeat the process if adjustment is still needed. If possible, avoid maxing out the adjusting screw for it may cause unwanted problems.