

Outdoor Storage Shed 10X8ft Manual

Dear customer,
Thank you for your support. If you have any questions or concerns, please don't hesitate to contact us. Our customer service team is always here to help and assist you in any way we can. Thank you again for choosing our outdoor storage shed.







Street: 8 The Green Suite A
City: Dover State: DE
Post code: 19901
Phone: 3022415039/
6605538327
Email: easyhelpservice@yahoo.com
Scan the code on your phone and
contact us via email.







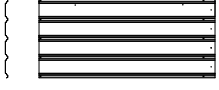

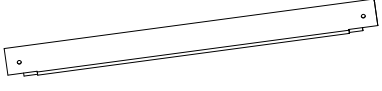
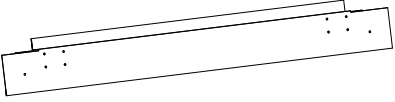
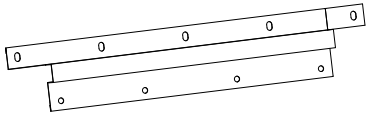
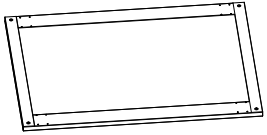













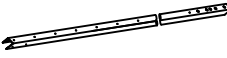

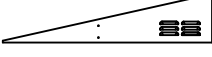
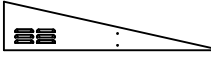
sannwsg.com















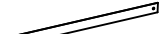







After-sales phone service hours:
US Central Time: 19:00-23:00
Seattle time: 17:00-21:00
US Eastern Time: 20:00-00:00
Toronto time: 20:00-00:00
Germany time: 8:00-11:00
After-sales mailbox service time:
7*24 hours

H1008parts list(A)

PART	NO.	QTY.
	W5-D	16
	W5-FA	1
	W5-KD	2
	K810-7L	2
	K810-7R	2
	K810-7M	6
	DCH1	2
	DCH2	2
	DCH6	1
	DCH	1

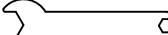
H1008parts list(B)

PART	NO.	QTY.
	W5-CD	4
	K1010-7MM	2
	W2-HLD	1
	W2-HRD	1
	K810-1	2
	K810-1R	2
	K810-2	2
	K710-2R	2
	K810-3	2
	K810-3L	2
	K810-4	2
	K710-4R	2
	K810-5L	2
	K810-5R	2
	K710-6	4
	K710-6R	4
	K810-8	4
	K710-9L	2
	K710-9R	2
	K810-10	1
	K710-10R	1
	UAD	2
	C3	4

PART	NO.	QTY.
	C4	4
	DAD	2
	DLAD	1
	DRAD	1
	DDA	4
	DBD	4
	GC	4
	GE	2
	T-F	4
	DC	4
	C2	4
	DH	4
	F1	449
	F2	56
	F3	32
	V2	136
	F4	4
	GL	1
	SL	54
	M20	1
	ST	2
	DH3	2
	DCH7	1

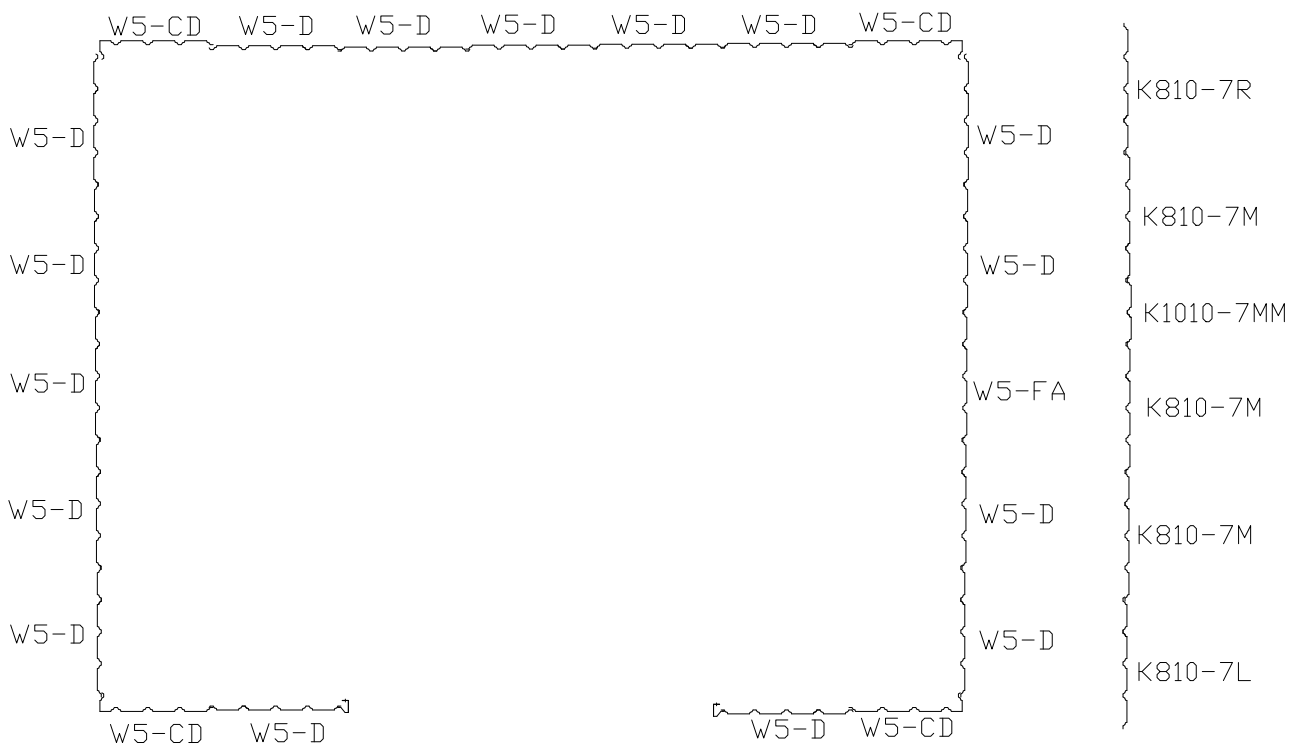

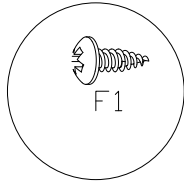

PART	NO.	QTY.
	K810-1	2
	K810-1R	2
	K810-2	2
	K710-2R	2
	T-F	4
	F1	36

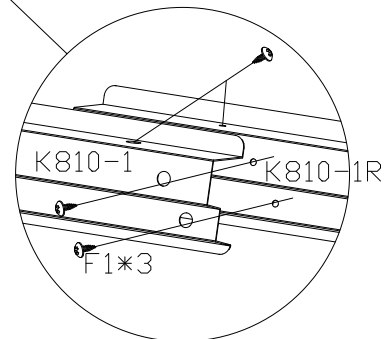
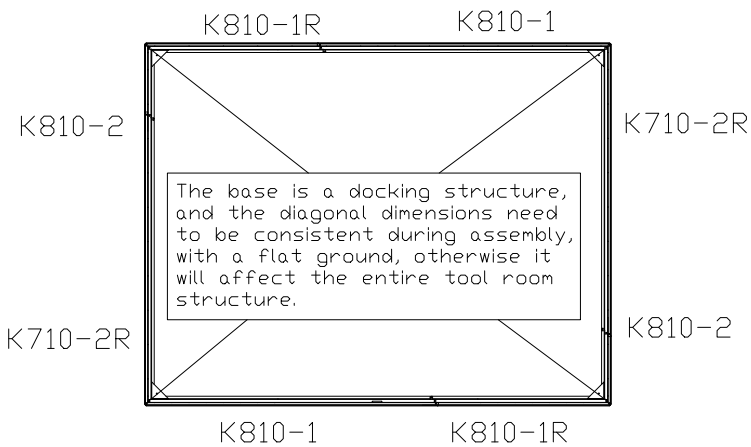
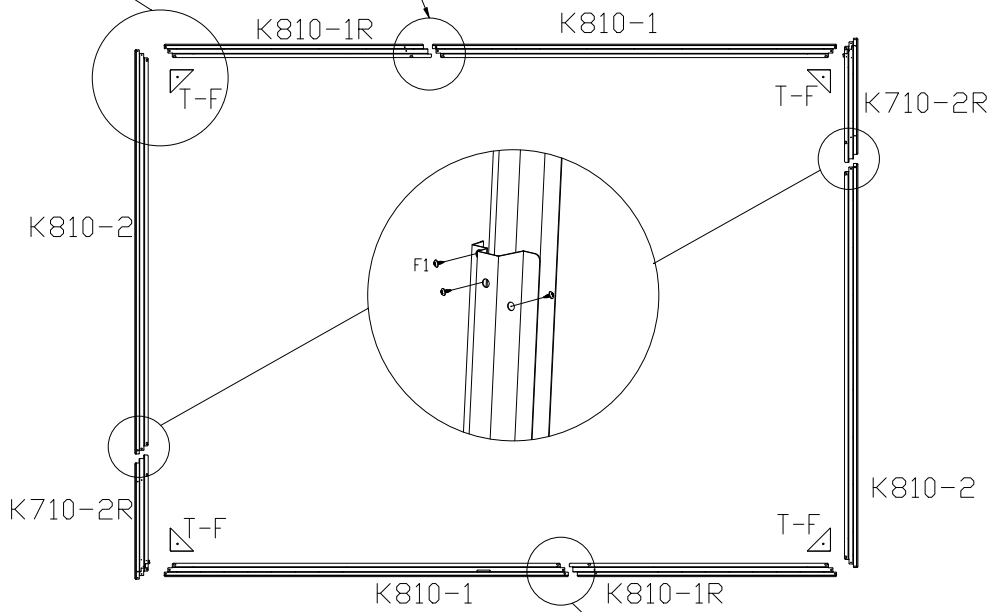
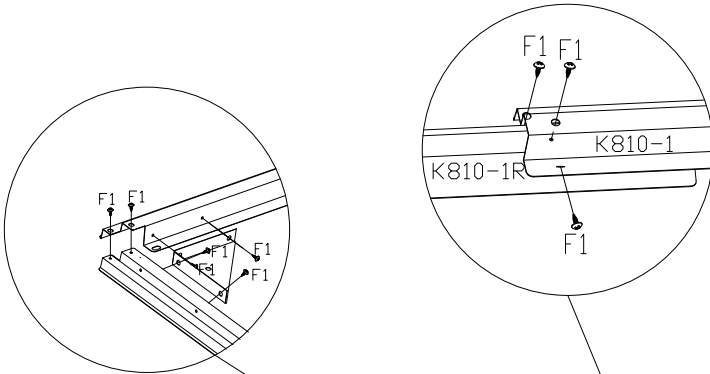

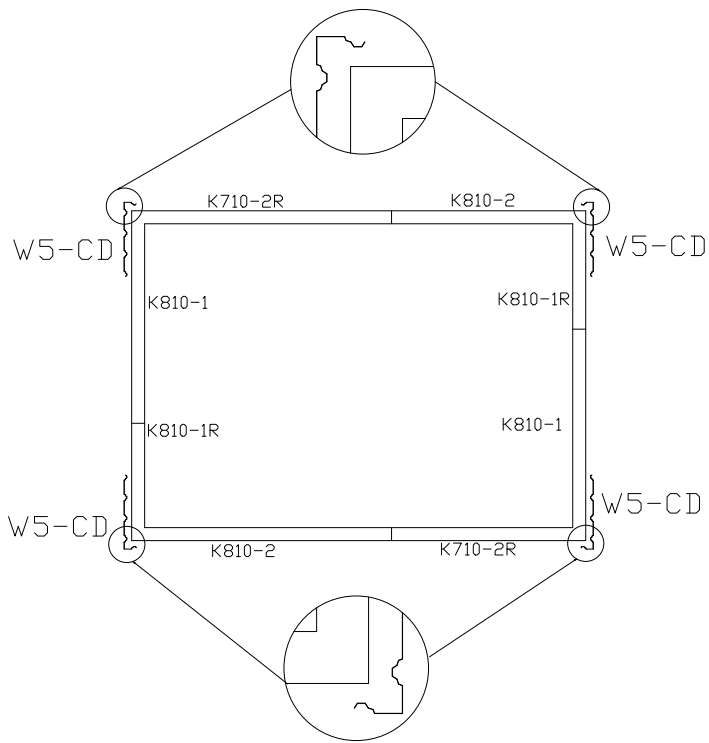



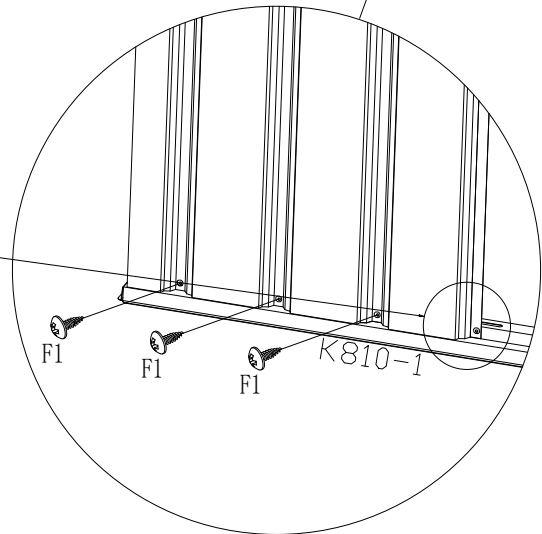
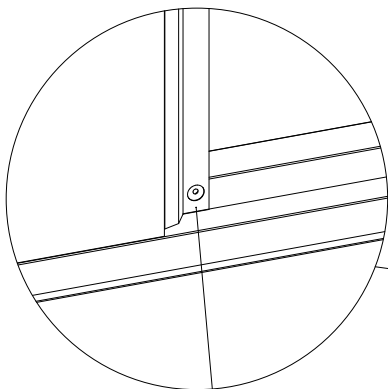
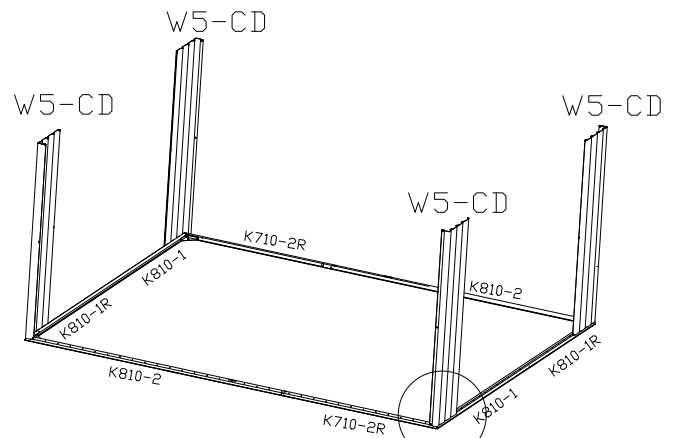
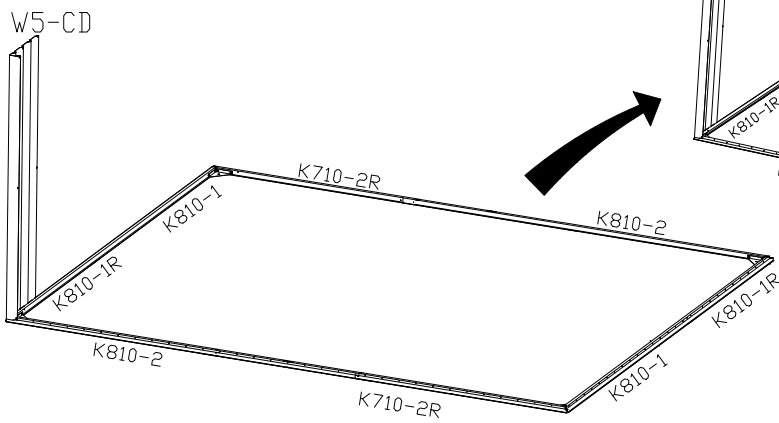

PART	NO.	QTY.
	W5-CD	4
	F1	12



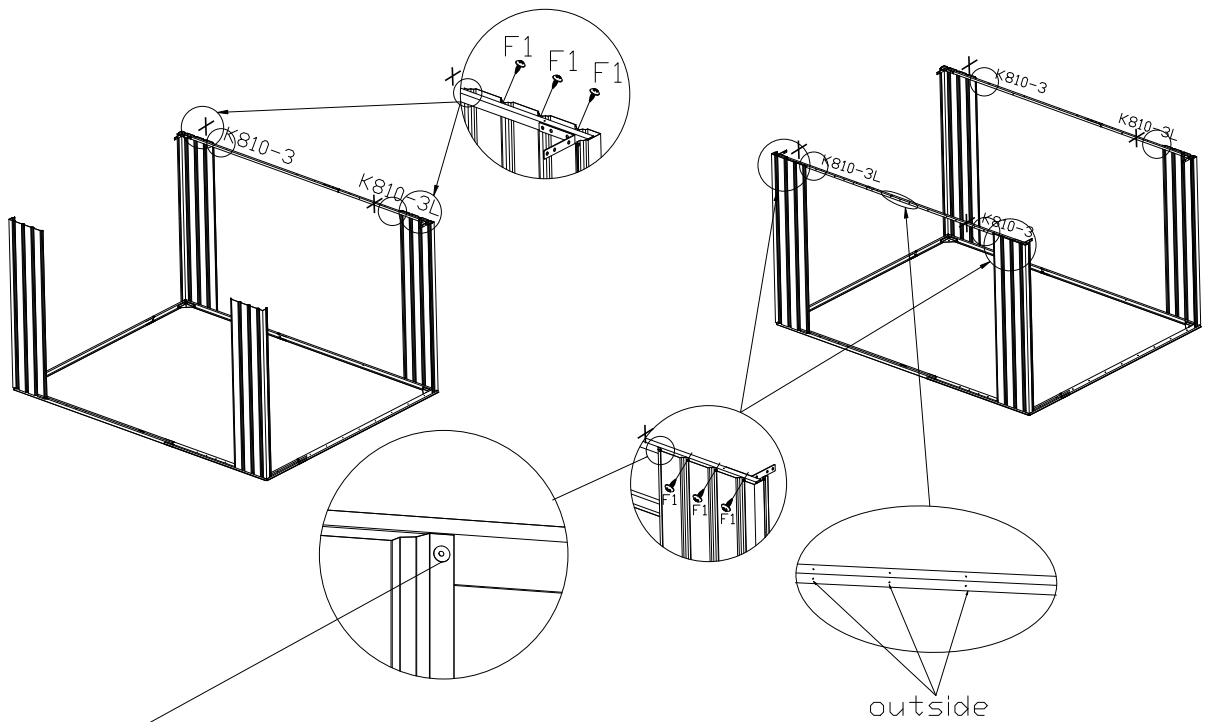
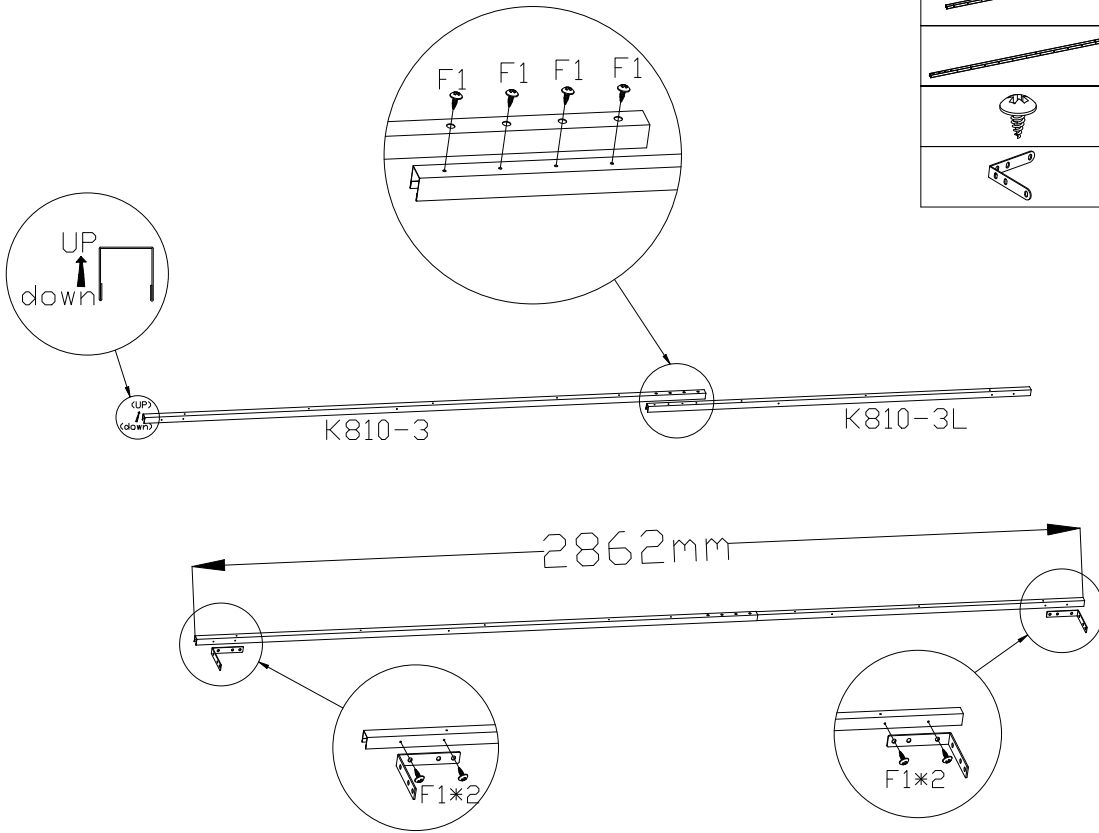

Dot not add screws that indicated with an X in diagram These need to be left undone.

PART	NO.	QTY.
	K810-3	2
	K810-3L	2
	F1	28
	C2	4



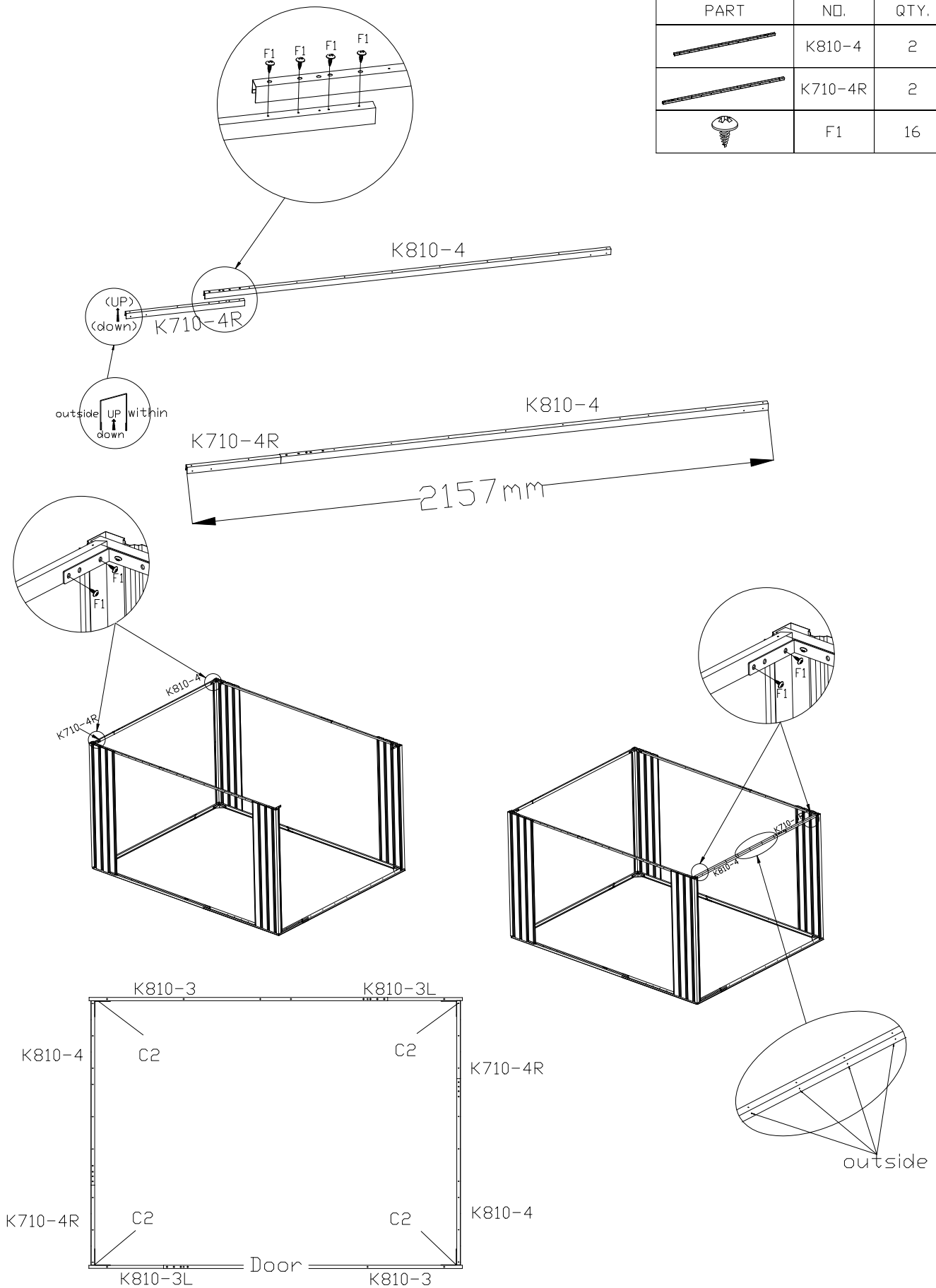

Dot not add screws that indicated with an X in diagram These need to be left undone.

PART	NO.	QTY.
	K810-4	2
	K710-4R	2
	F1	16

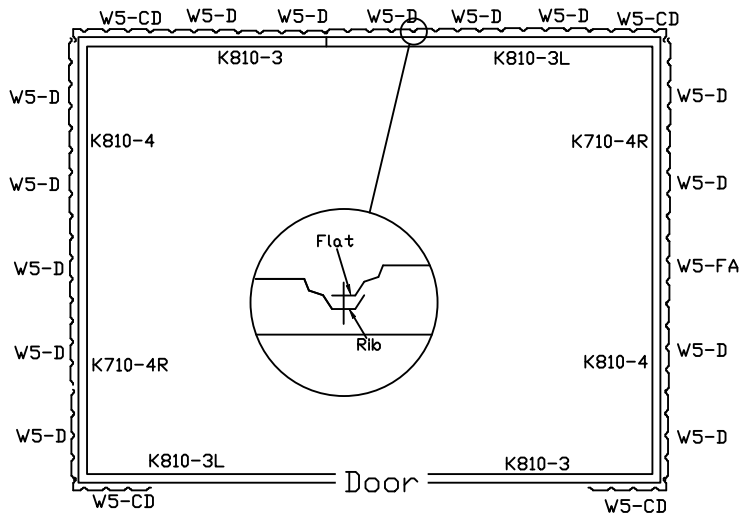



PART	NO.	QTY.
	W5-D	5
	F1	42
	F2	6

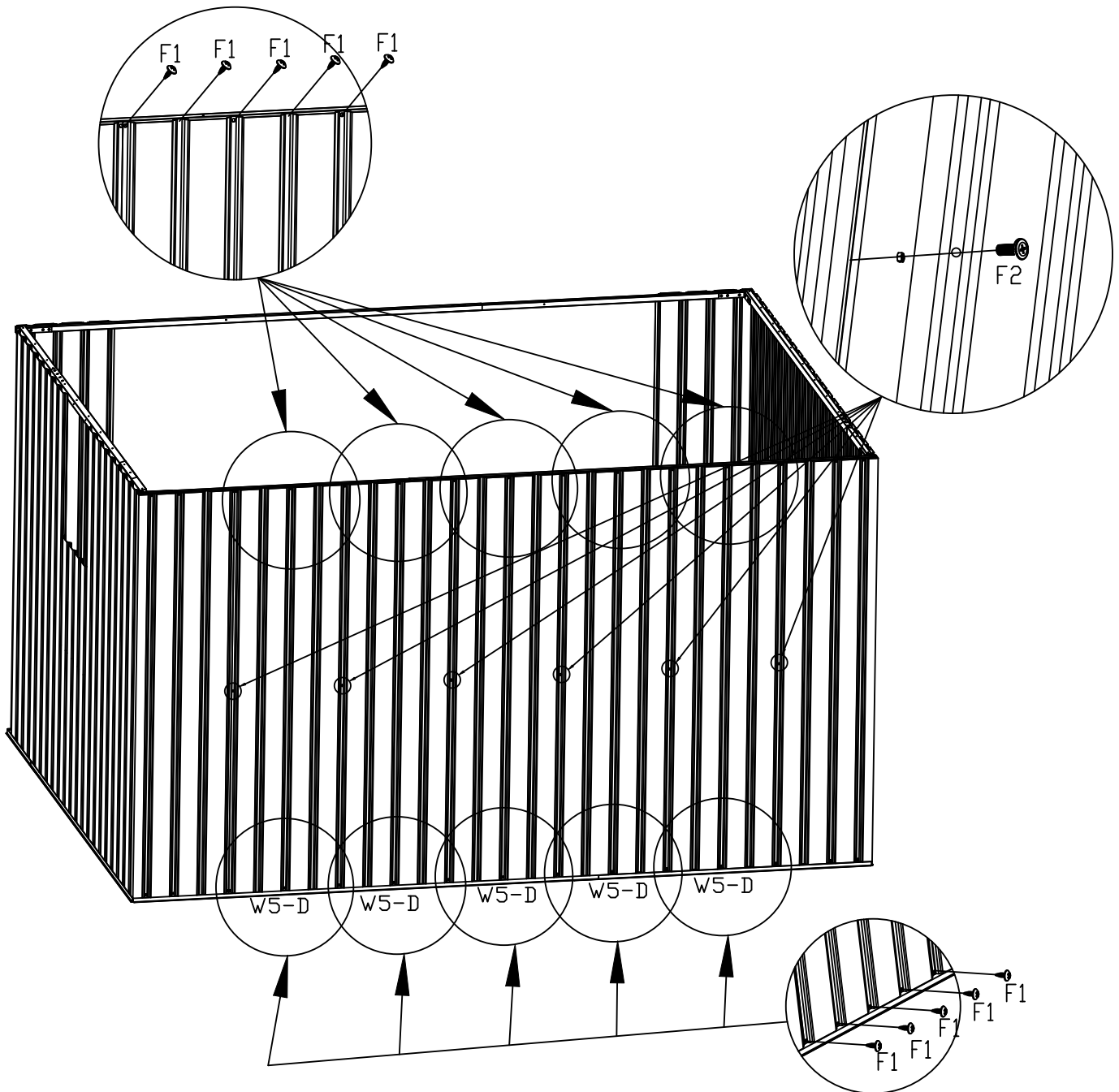

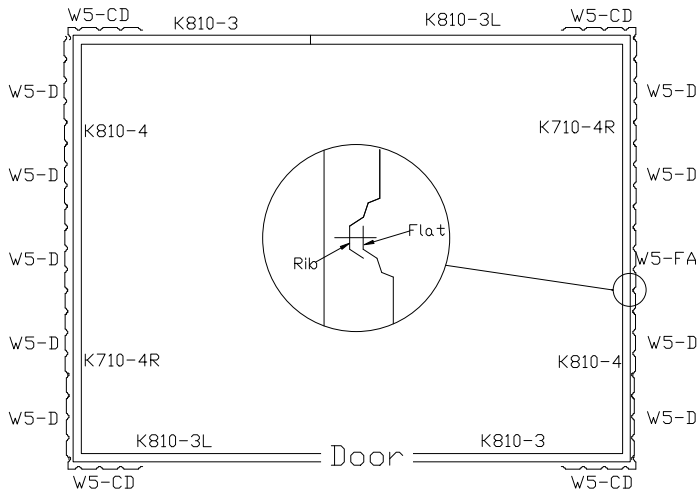



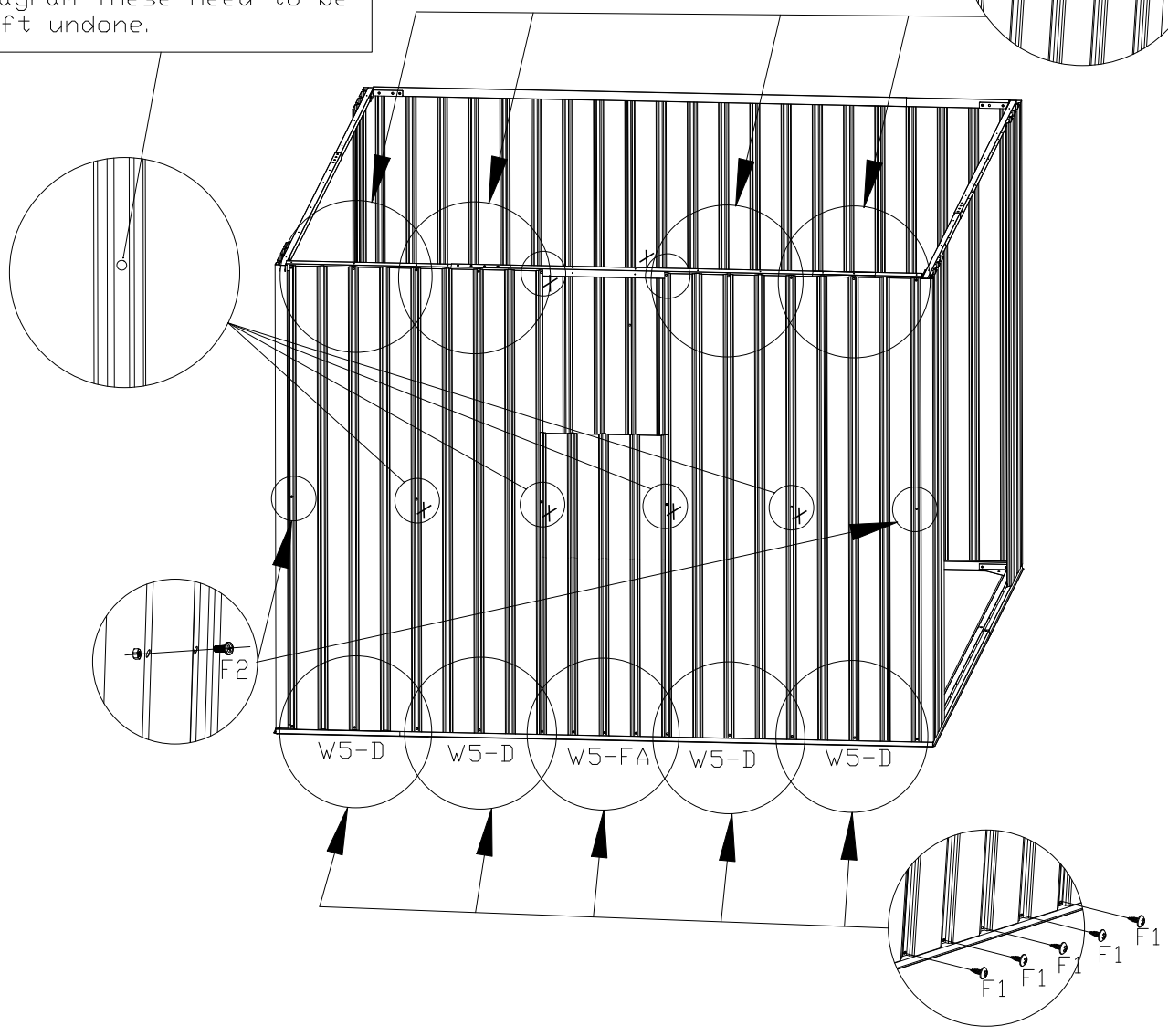
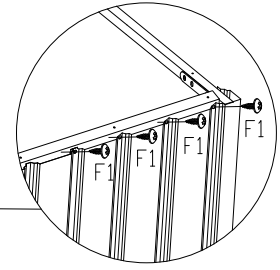

PART	NO.	QTY.
	W5-D	4
	W5-FA	1
	F1	37
	F2	2

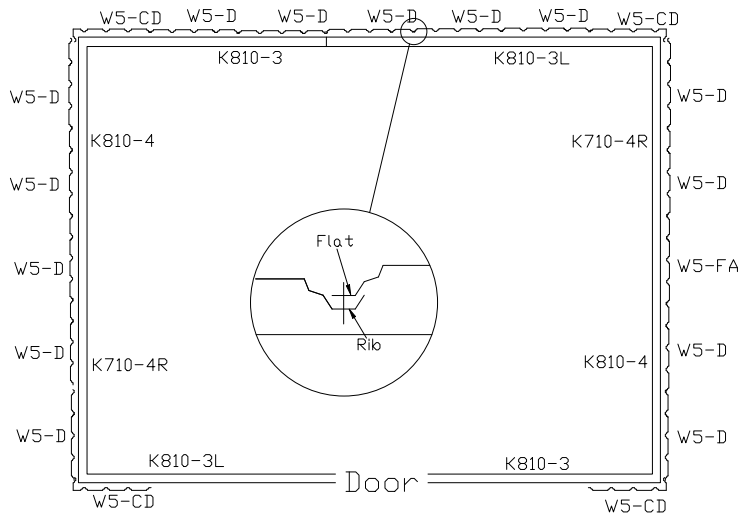
Dot not add screws that indicated with an X in diagram These need to be left undone.







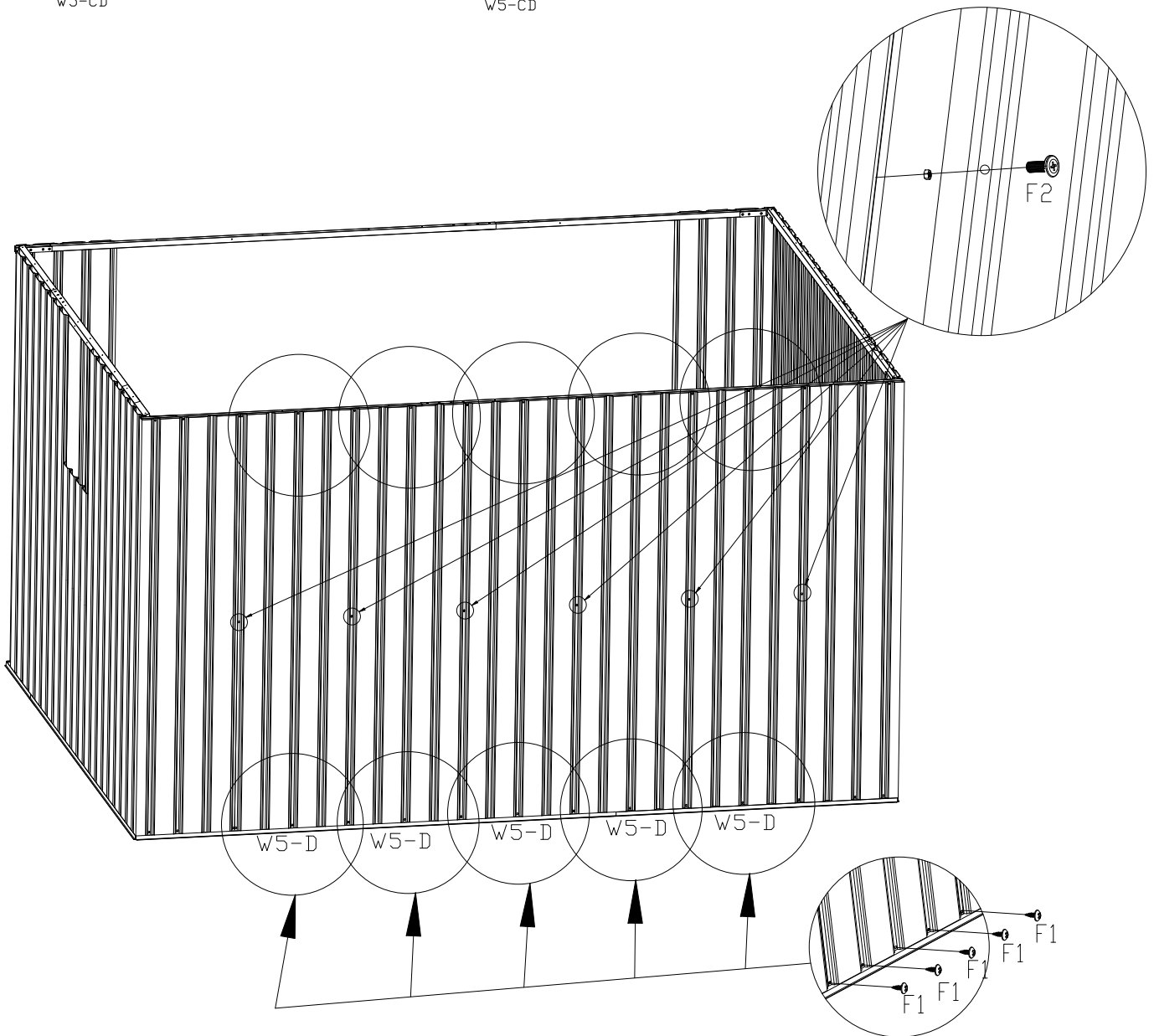

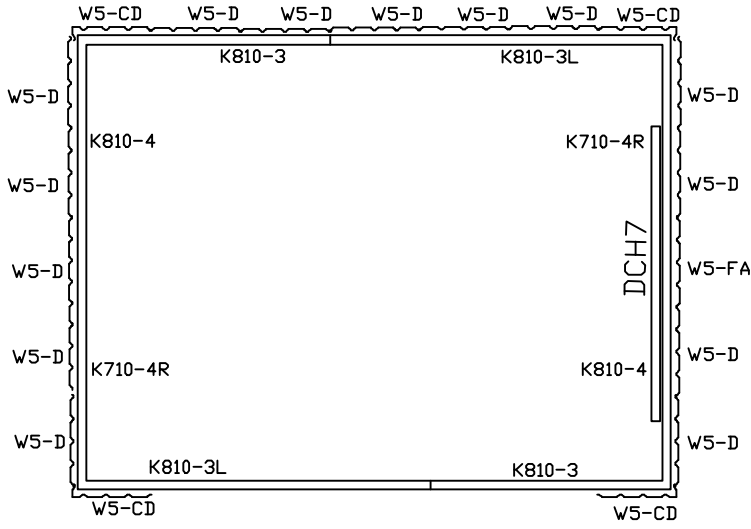

PART	NO.	QTY.
	W5-D	5
	F1	42
	F2	6



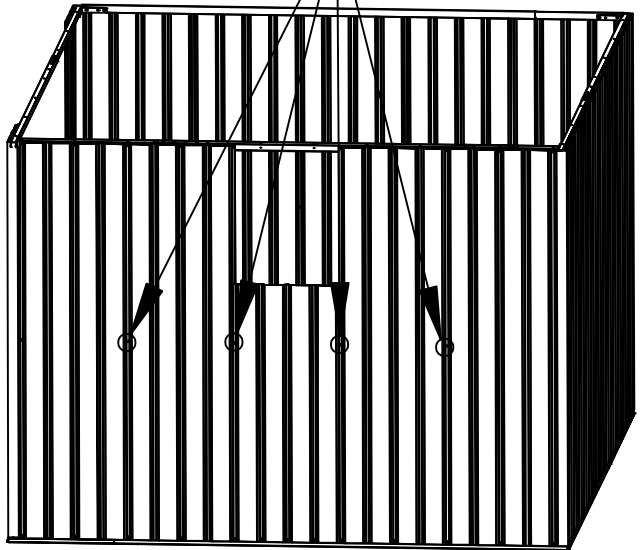
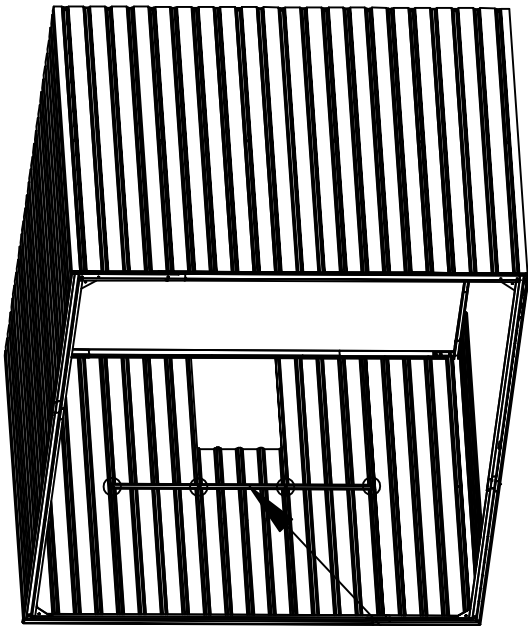
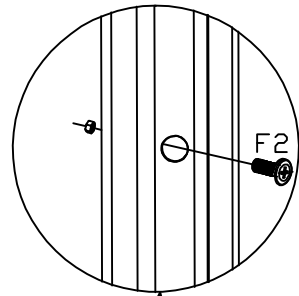

PART	NO.	QTY.
	DCH7	1
	F2	4



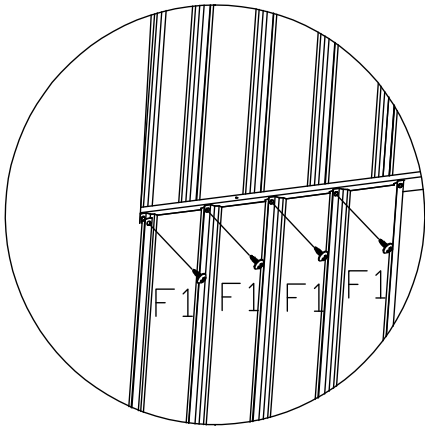
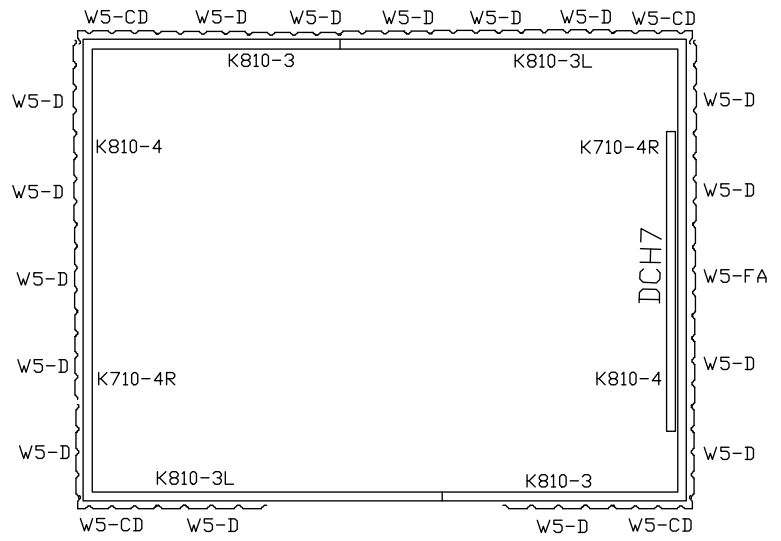

PART	NO.	QTY.
	W5-D	2
	F1	16
	F2	2

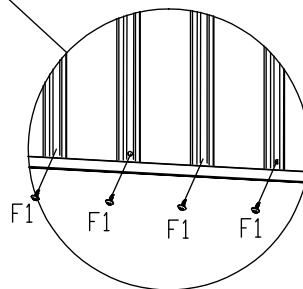
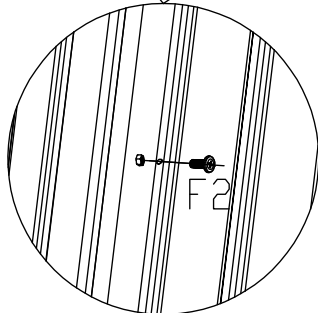
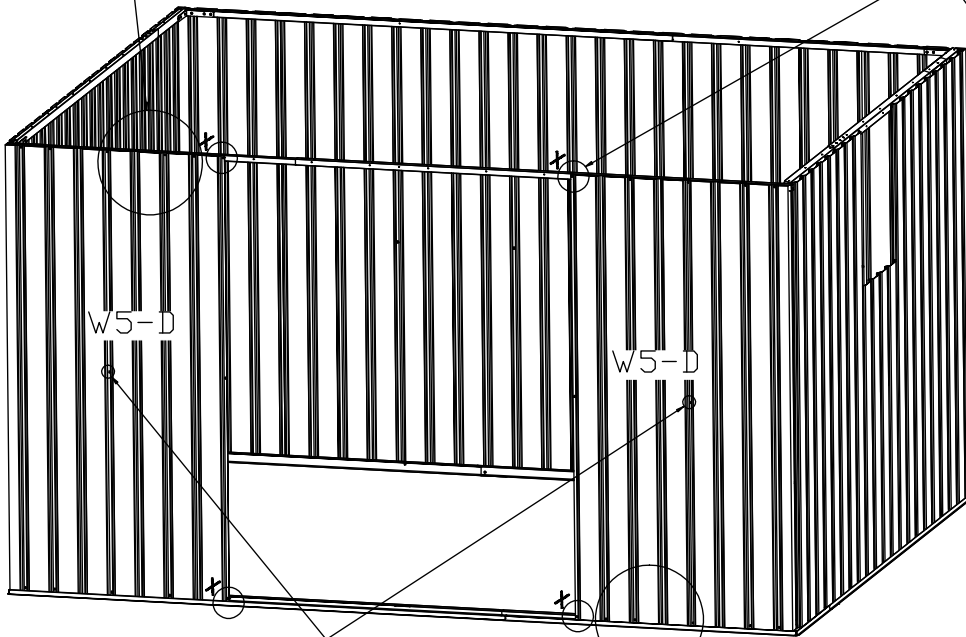
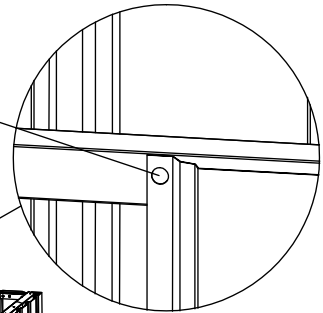

Do not add screws that indicated with an X in diagram. These need to be left undone.



PART	NO.	QTY.
	UAD	2
	F1	8
	F2	2

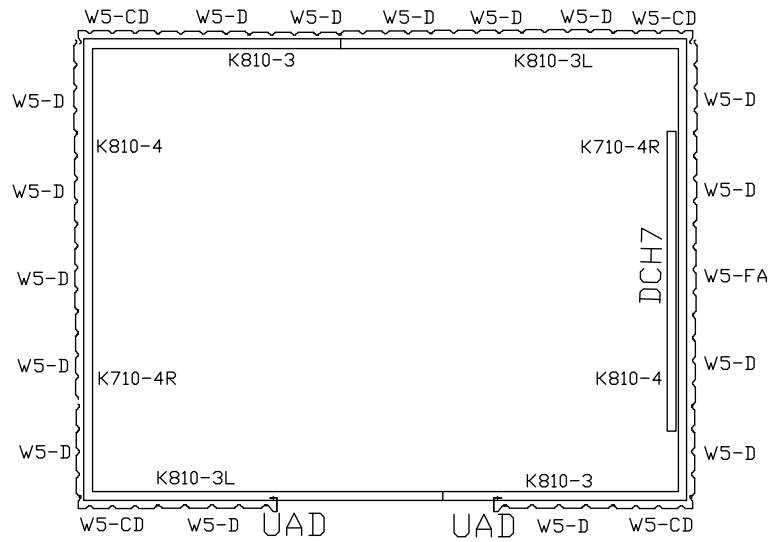

① UAD notch is inserted into K810-3L/K810-3.

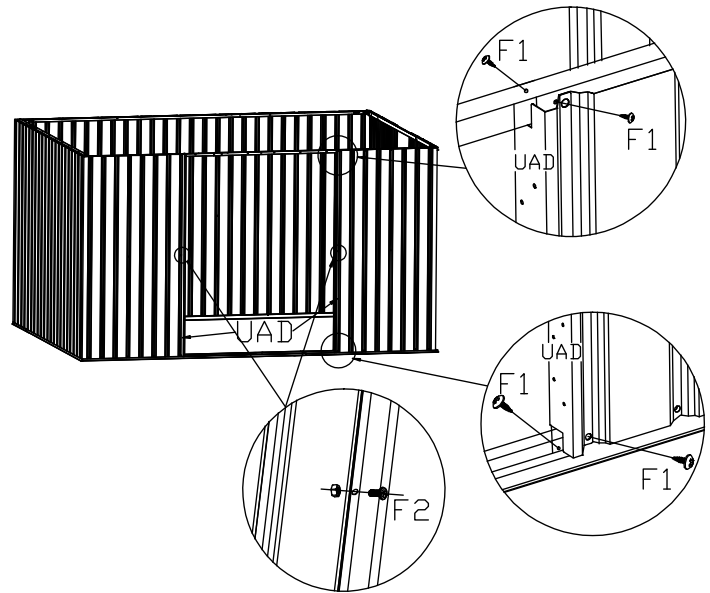
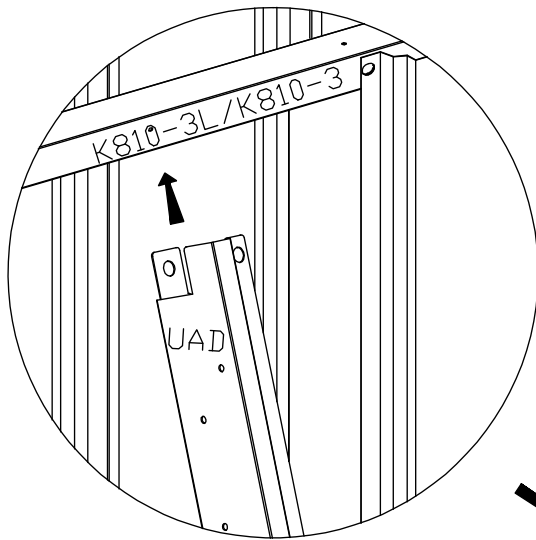

④ F1 screw fixation

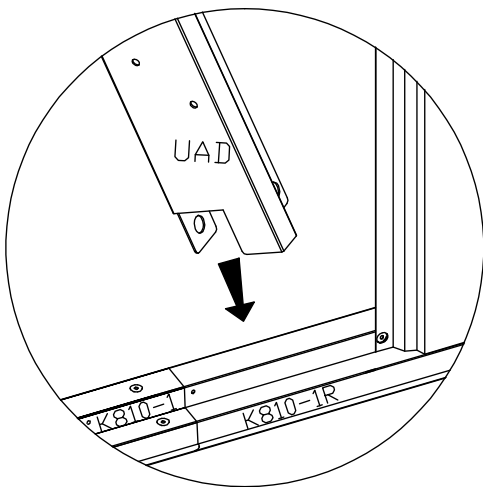

② UAD notch is inserted into K810-1/K810-1R.

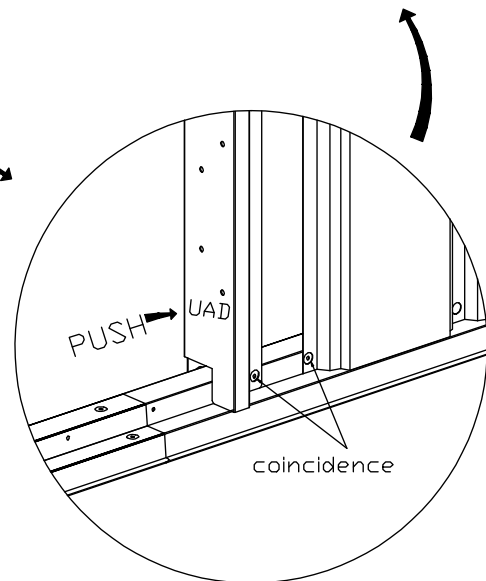

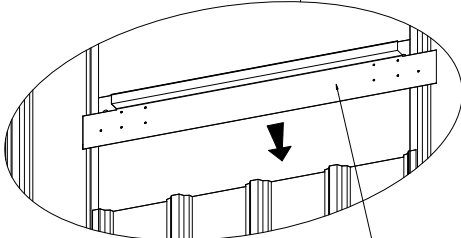
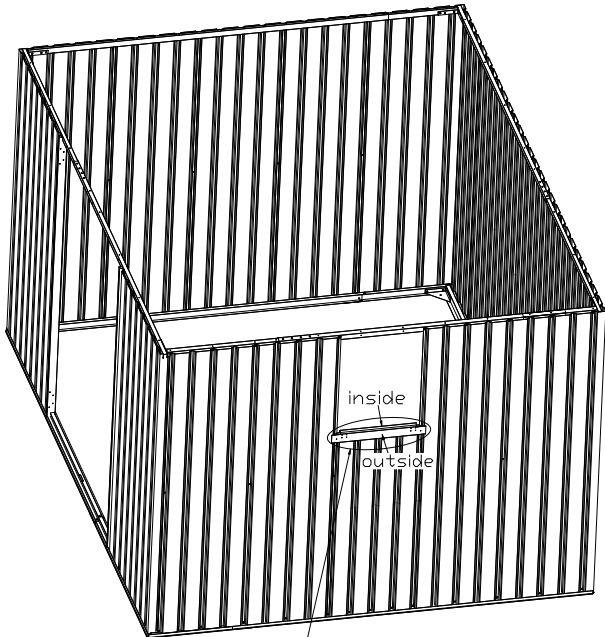

③ Push UAD and W5-D screw holes to coincide.

PART	NO.	QTY
	DCH2	1

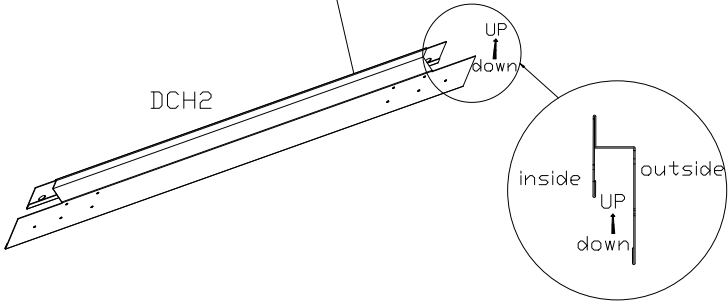

Installation method:
 Insert the DCH2 slot onto the W5-FA,
 The long side faces outward and
 does not require screws for fixation.



PART	NO.	QTY
	DCH1	2
	F1	4

front

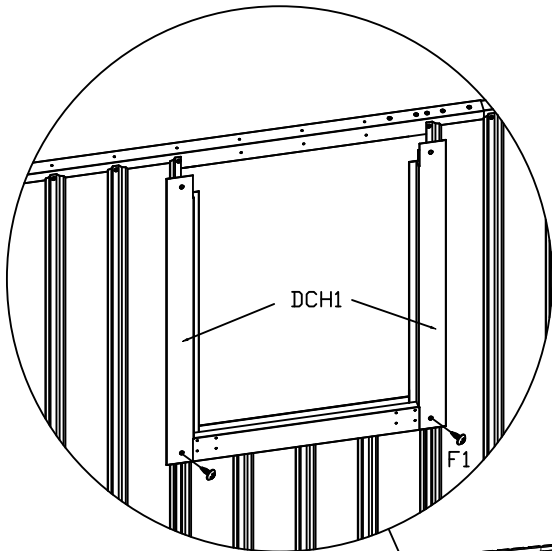

back

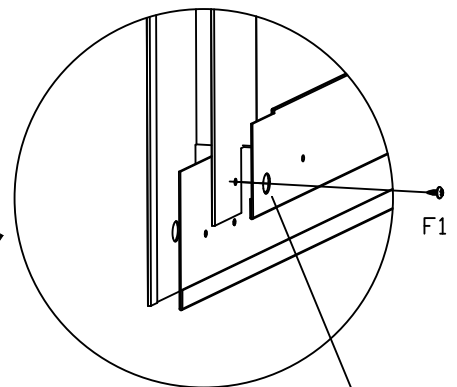
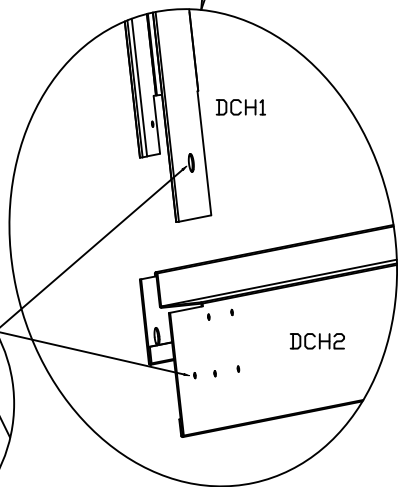
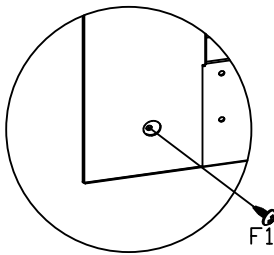
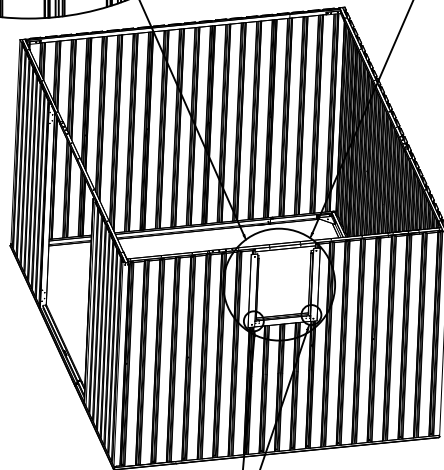
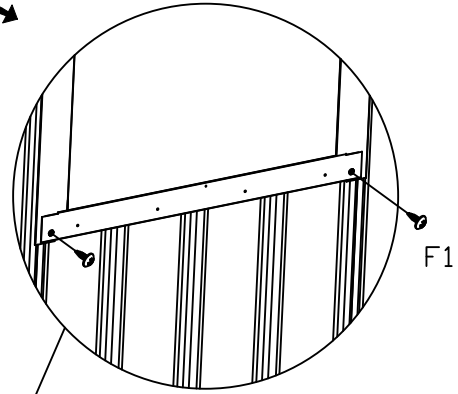

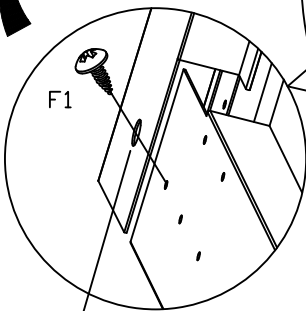

The big hole is outside.

back



The big hole is outside.

front

PART	NO.	QTY
	DCH2	1
	F1	4

Installation method:
Push DCH2 from top to bottom into DCH1,
and finally secure it with F1 screws.

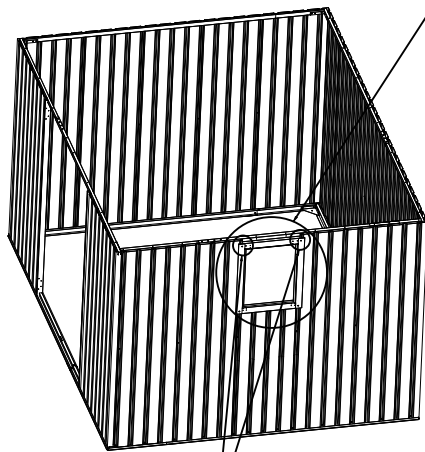
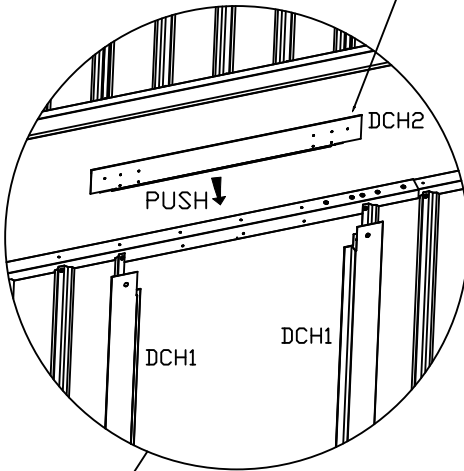
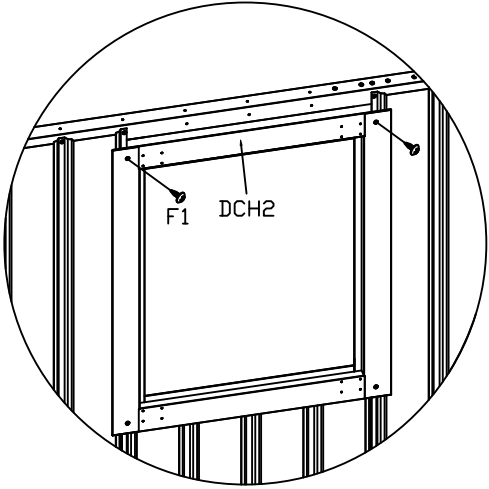

The big hole is outside

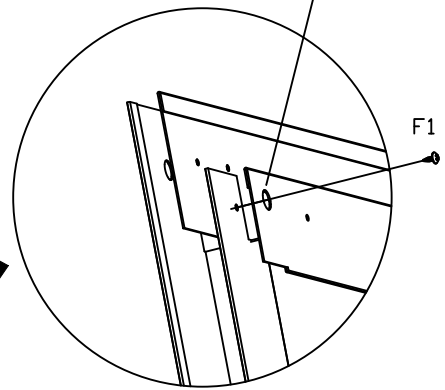
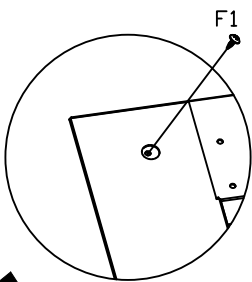

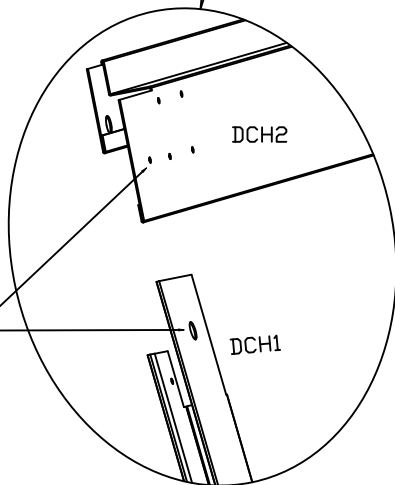

back

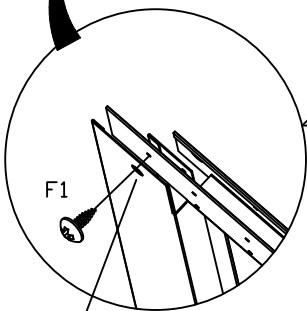

front





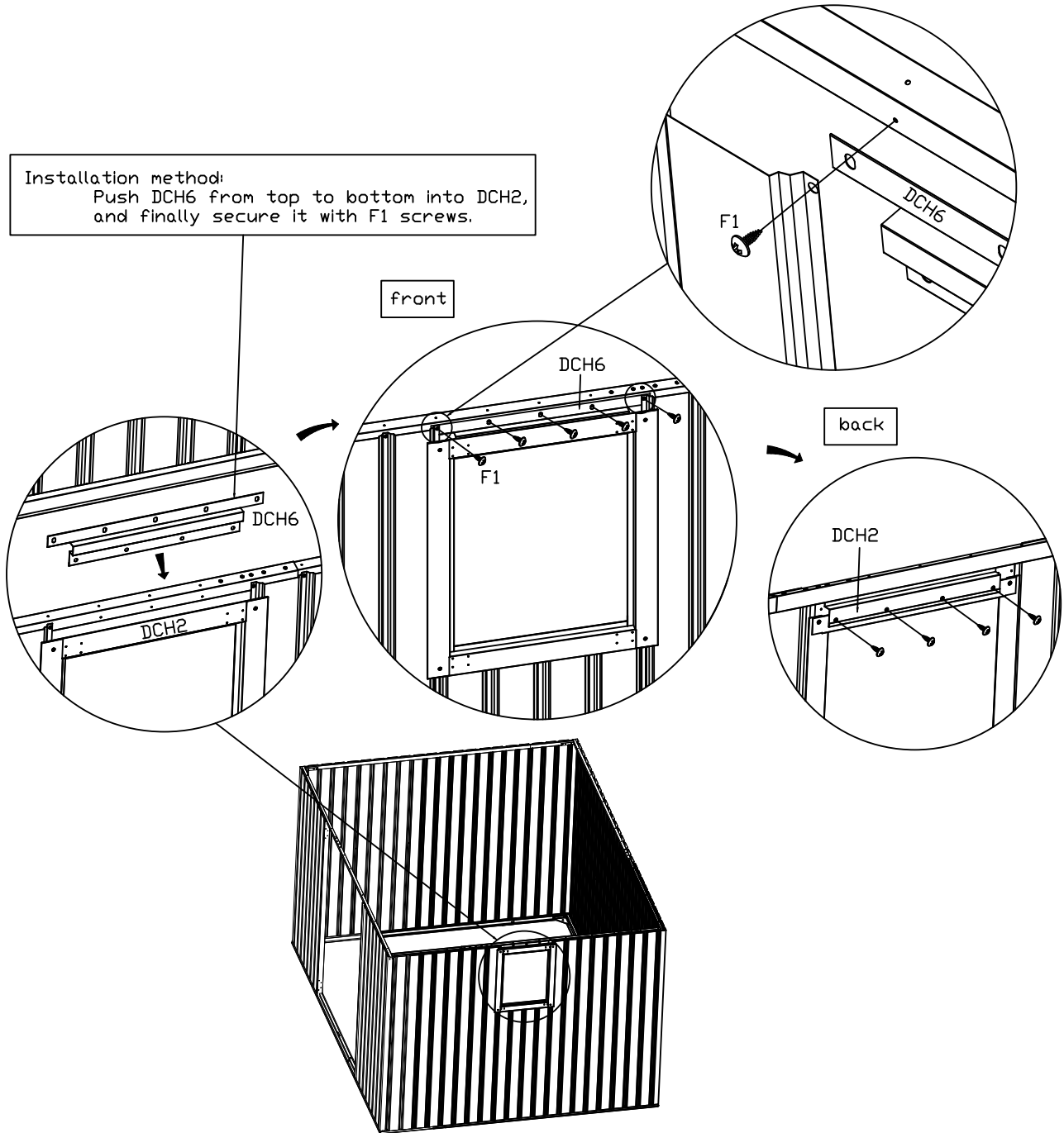

The big hole is outside.

PART	NO.	QTY
	DCH6	1
	F1	9

Installation method:
Push DCH6 from top to bottom into DCH2,
and finally secure it with F1 screws.



PART	NO.	QTY
	DCH	1
	DC	2
	F1	4
	V2	4

Install the left pin on the left side.

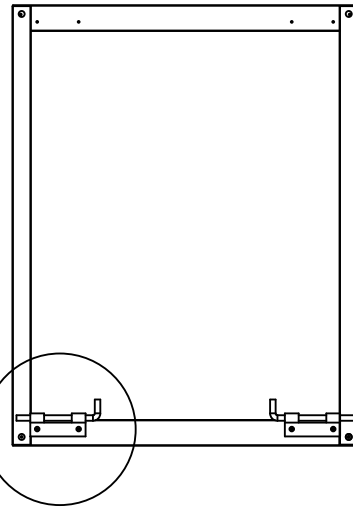
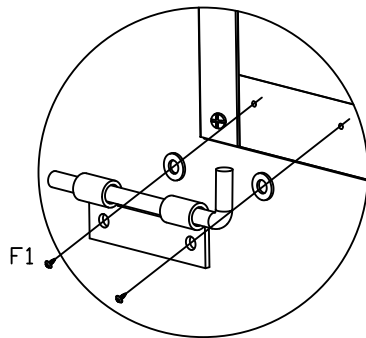
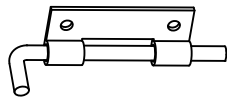

Step 2



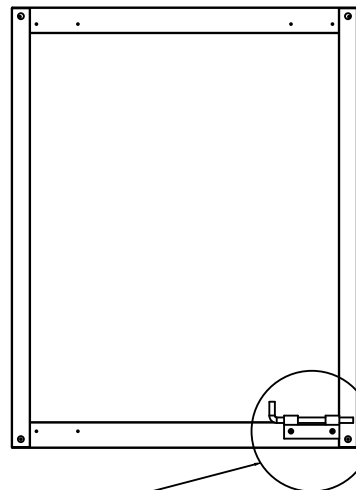
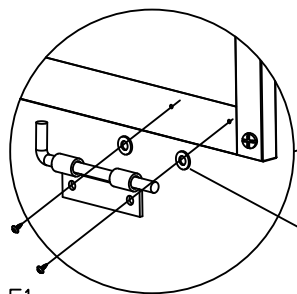
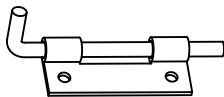

Install the pin on the right side.



Step 1

If the pin is a bit tight,
2 washers can be installed here.

PART	NO.	QTY
	DH3	2
	F1	8

Installation sequence of screws: ①—②—③—④

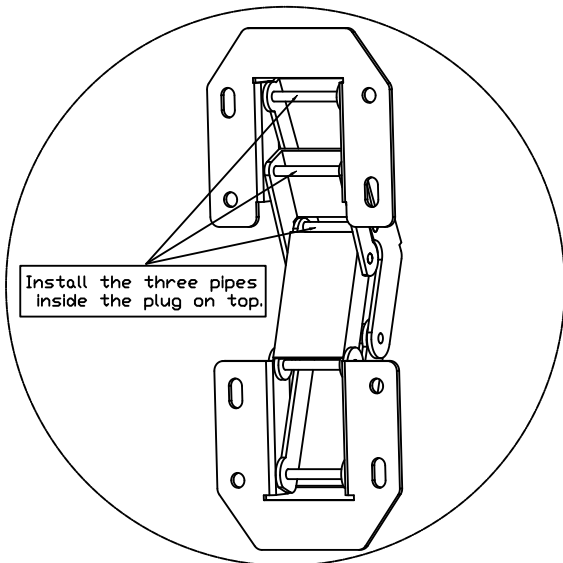

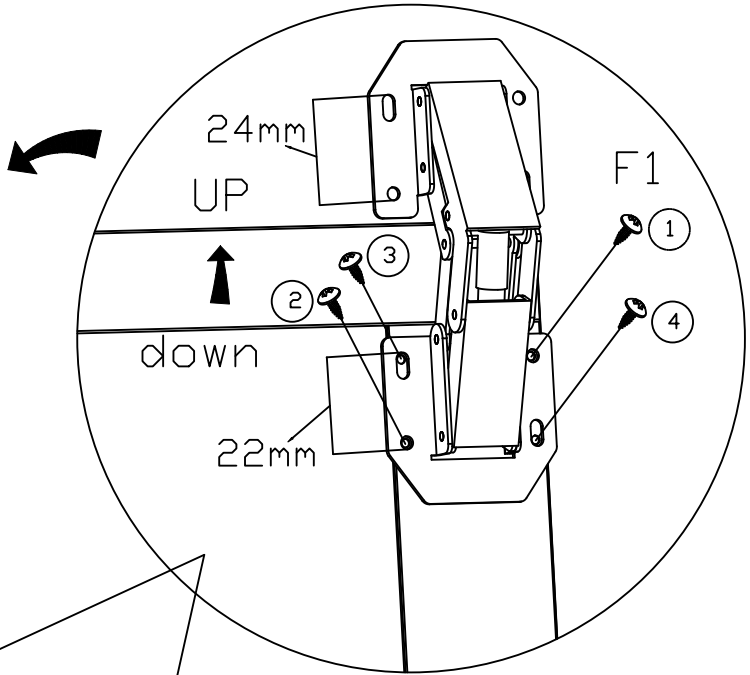

back

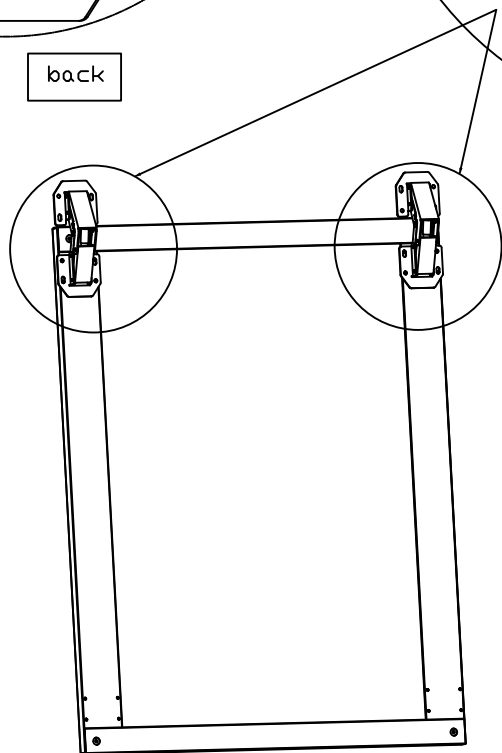

front





Component 1

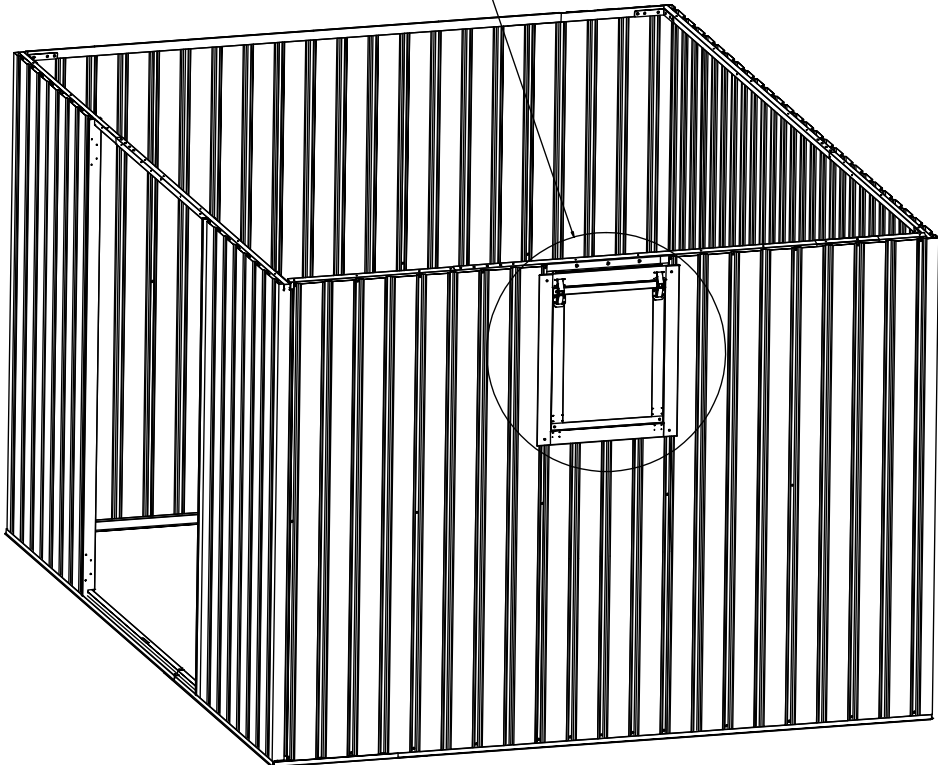
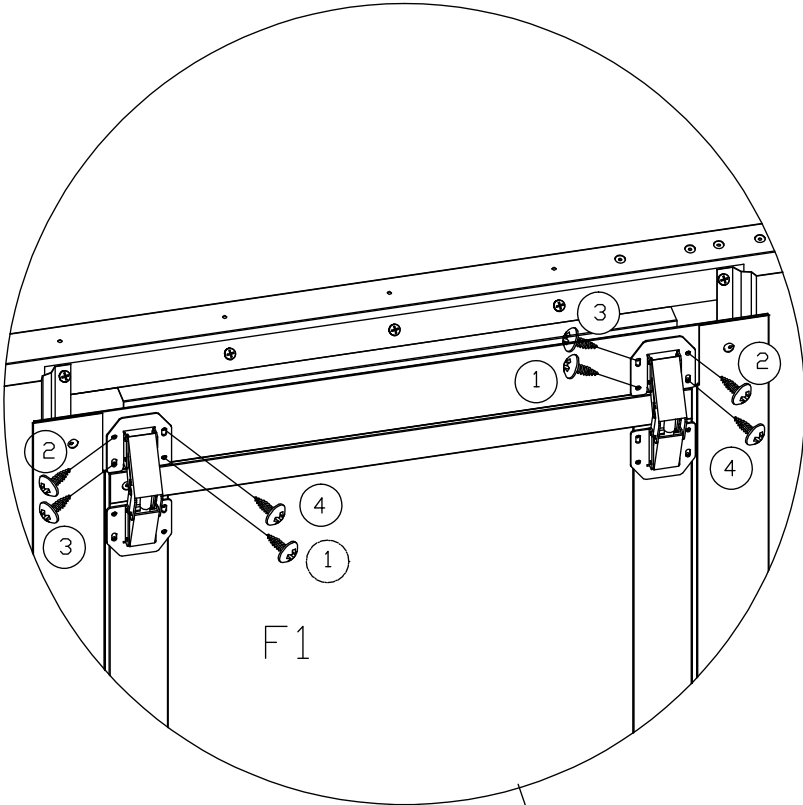

PART	NO.	QTY
	Component 1	1
	F1	8

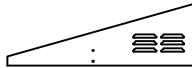
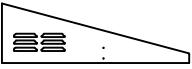
Installation sequence of screws: ① → ② → ③ → ④



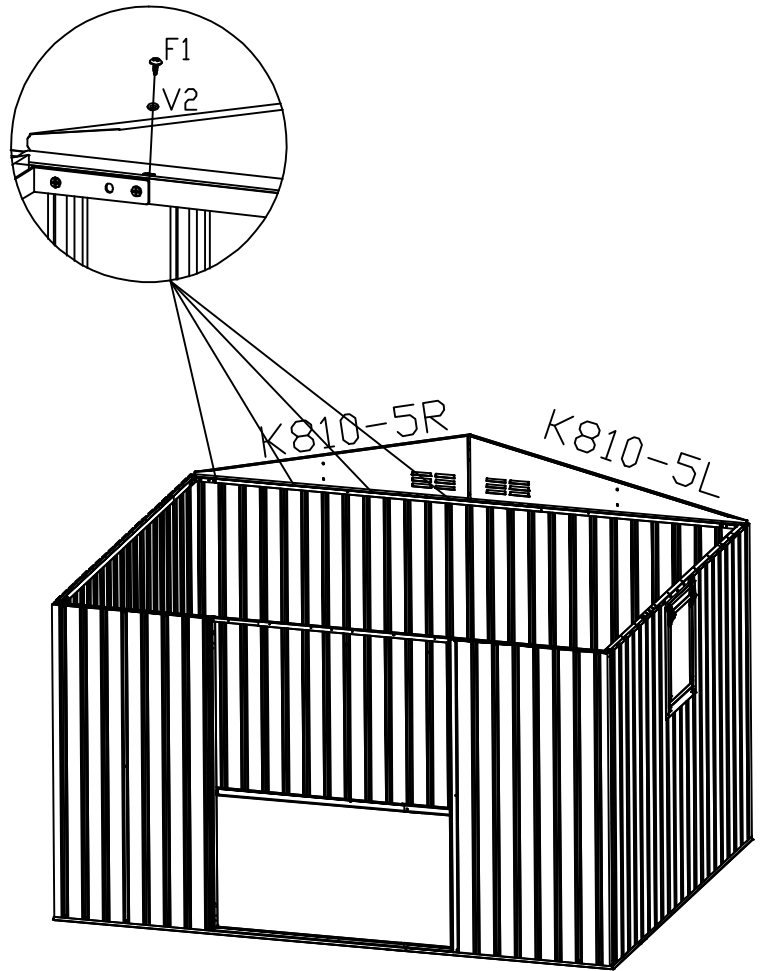
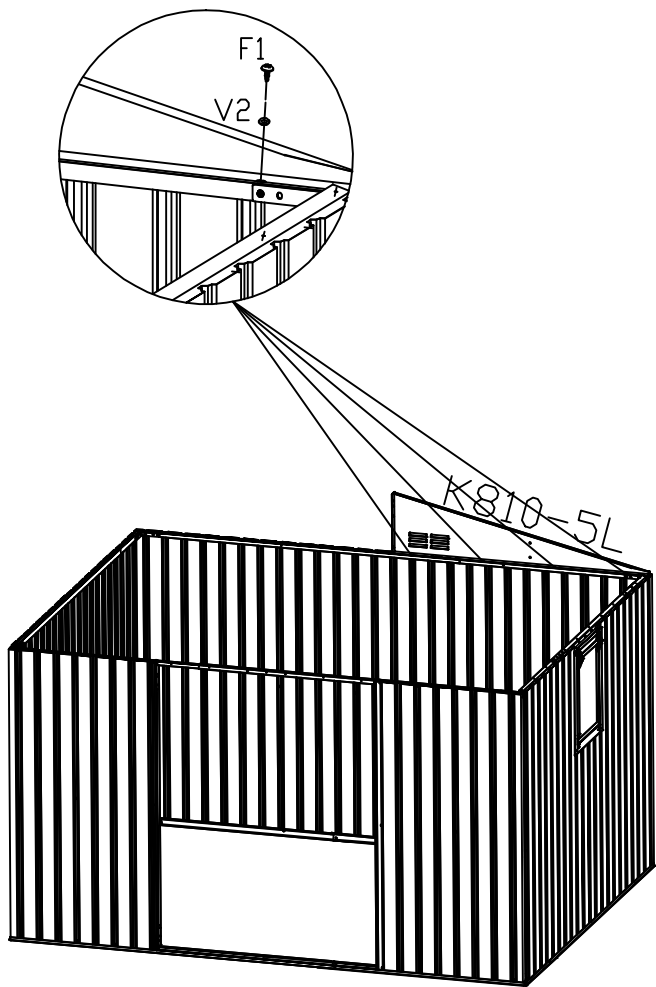

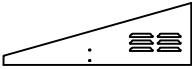
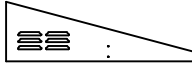

PART	NO.	QTY.
	K810-5L	1
	K810-5R	1
	F1	8
	V2	8

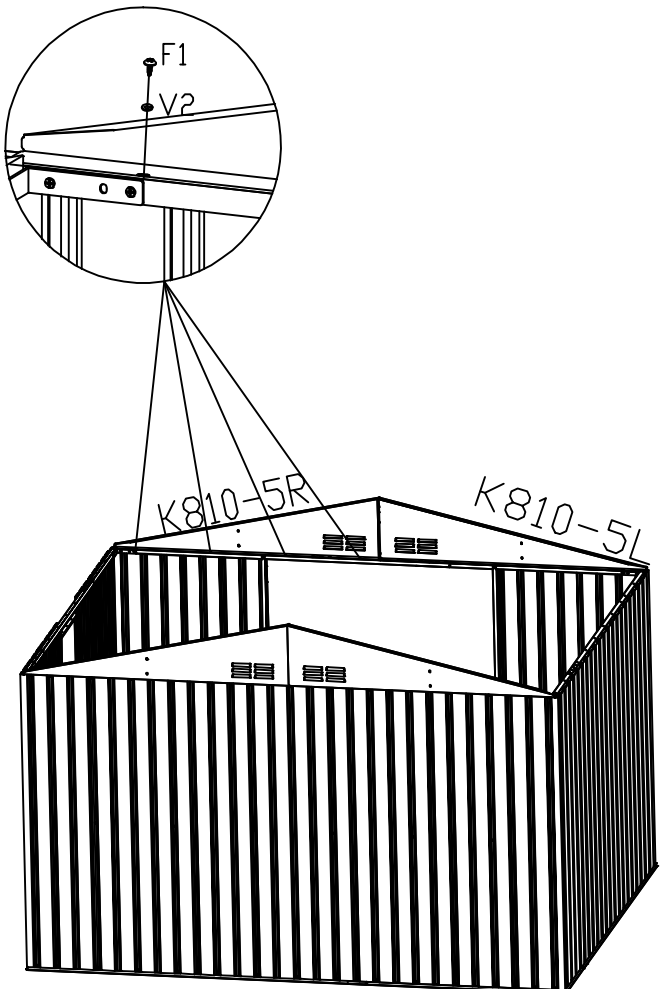
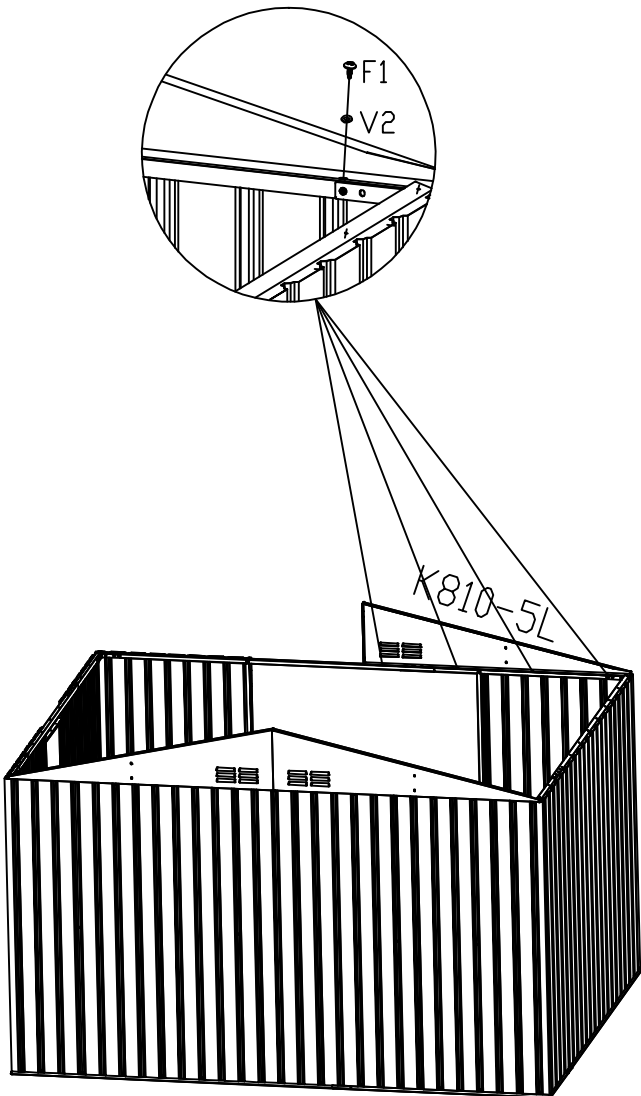

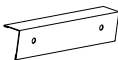

PART	NO.	QTY.
	K810-5L	1
	K810-5R	1
	F1	8
	V2	8

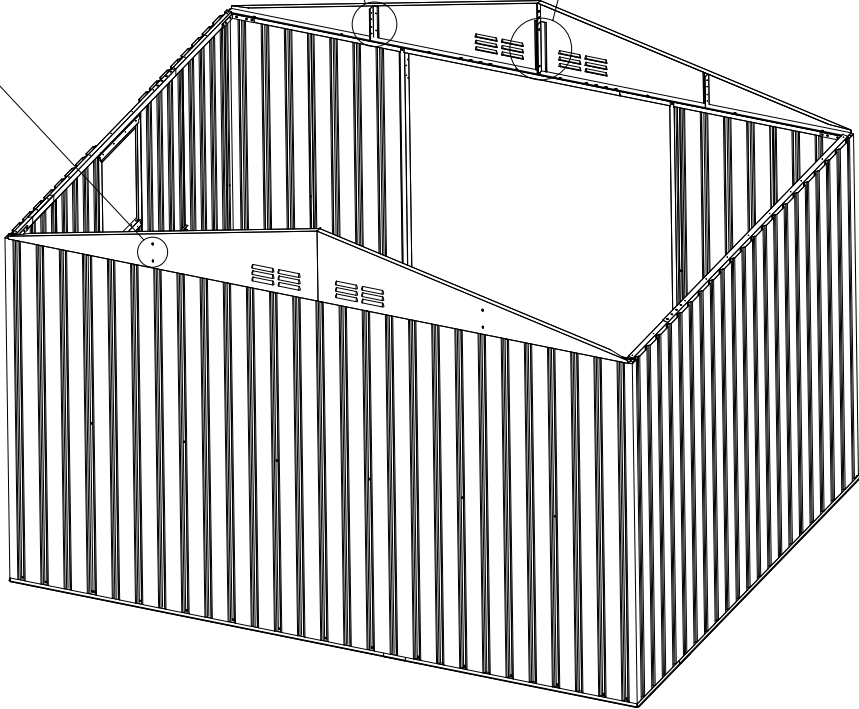
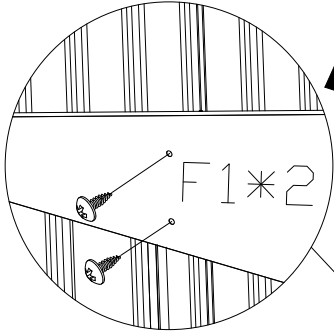
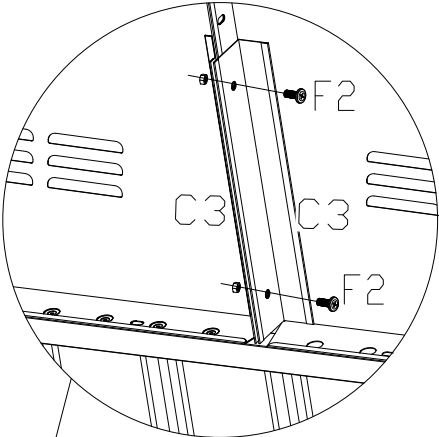
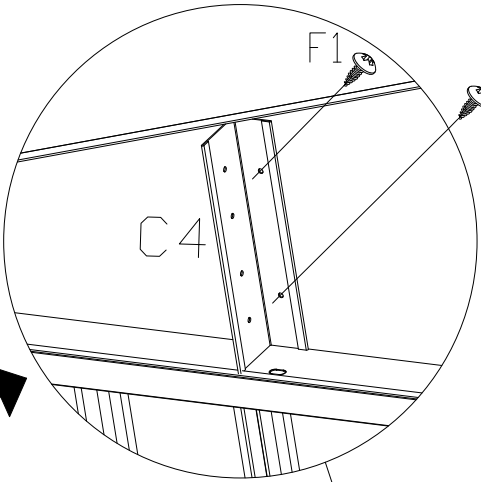
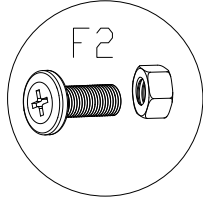

PART	NO.	QTY.
	C3	4
	C4	4
	F2	4
	F1	8



PART	NO.	QTY.
	K710-6	2
	K710-6R	2
	F2	10

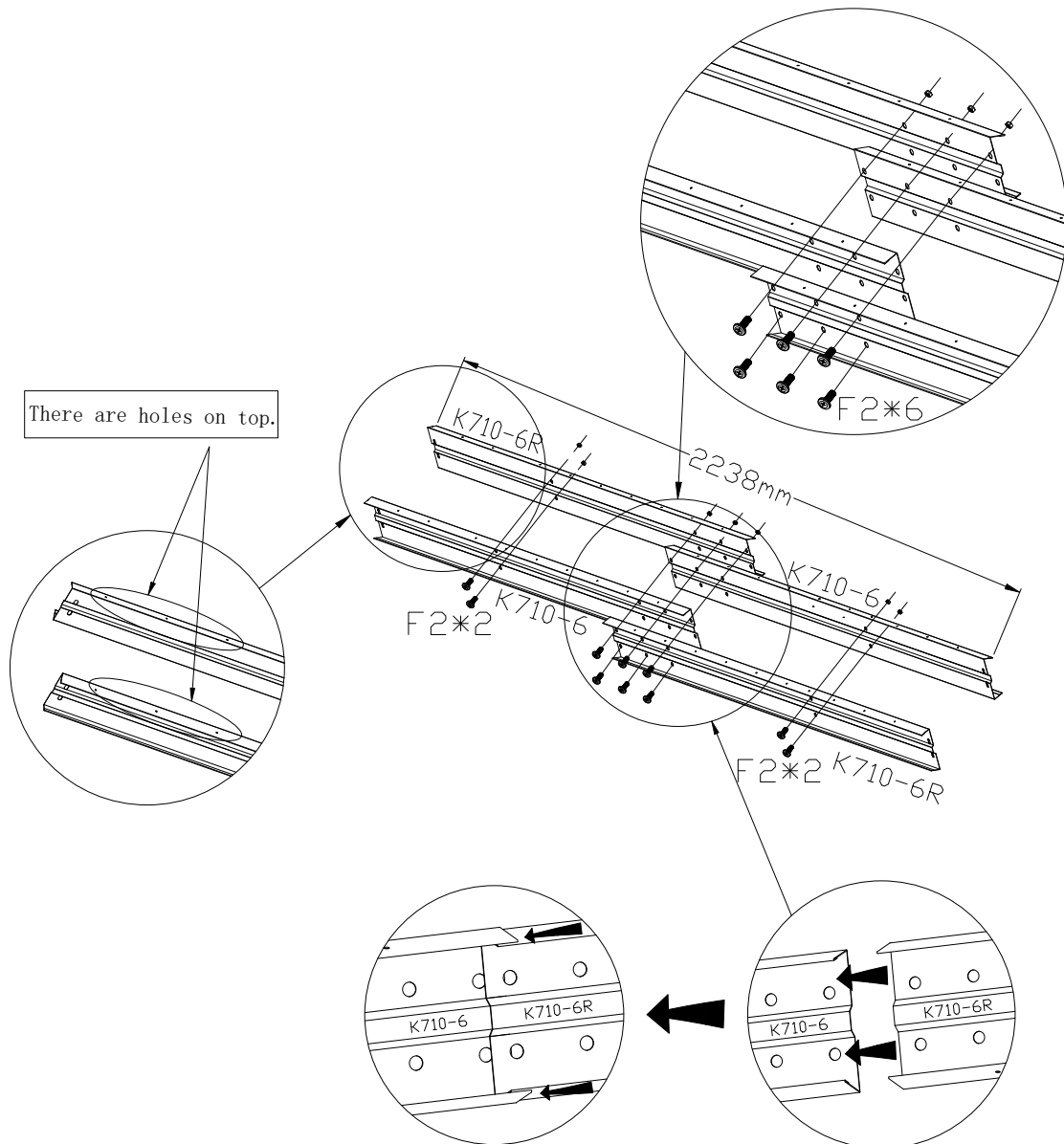



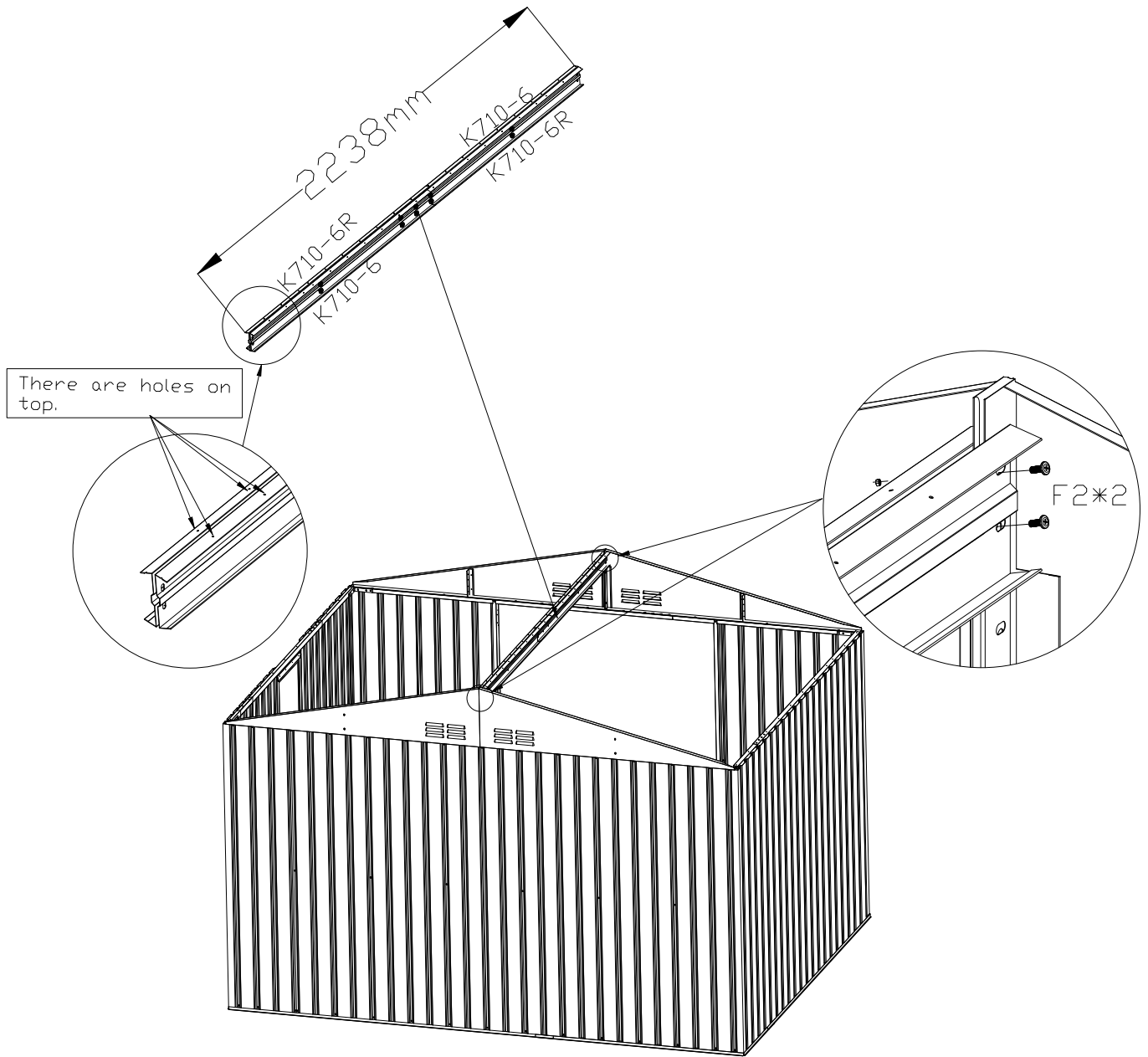

K710-6R has a smaller width and is inserted into K710-6 with aligned holes.

PART	NO.	QTY.
	F2	4

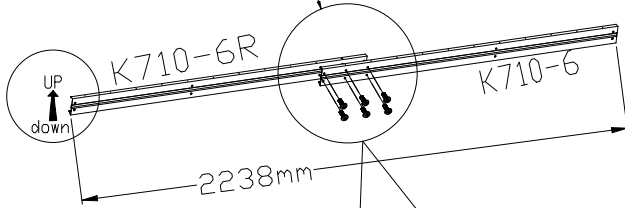
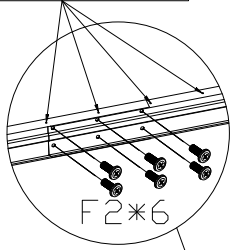

There are holes on top.



PART	NO.	QTY.
	K710-6	2
	K710-6R	2
	F2	12
	F1	8

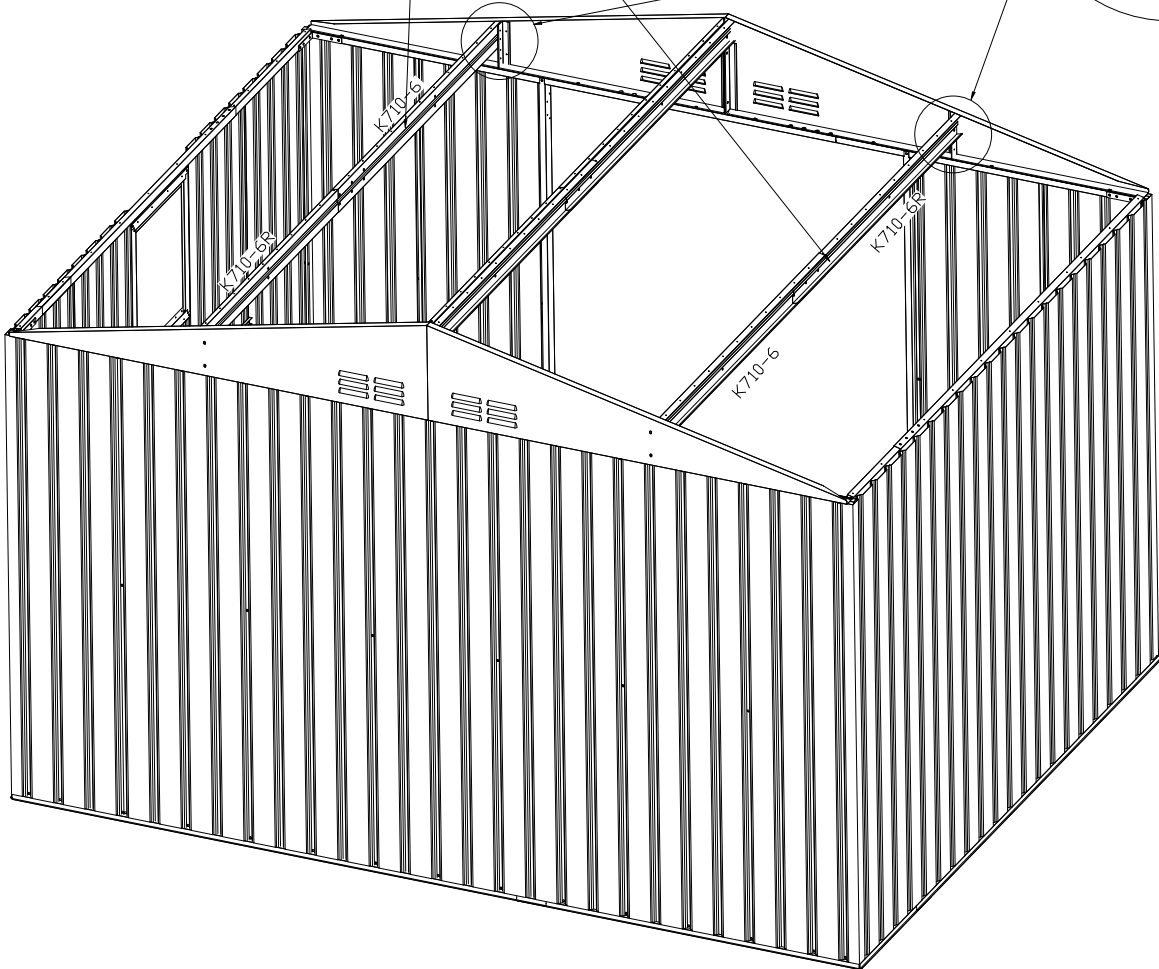

This is the installation of flat edges and K810-8, otherwise, there will be interference phenomena.

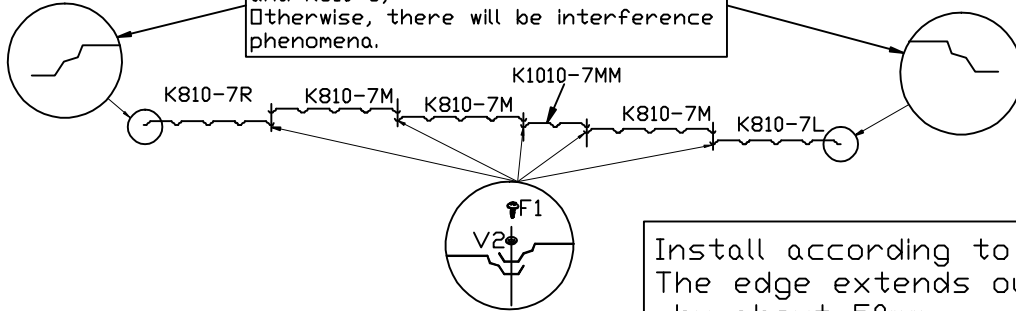



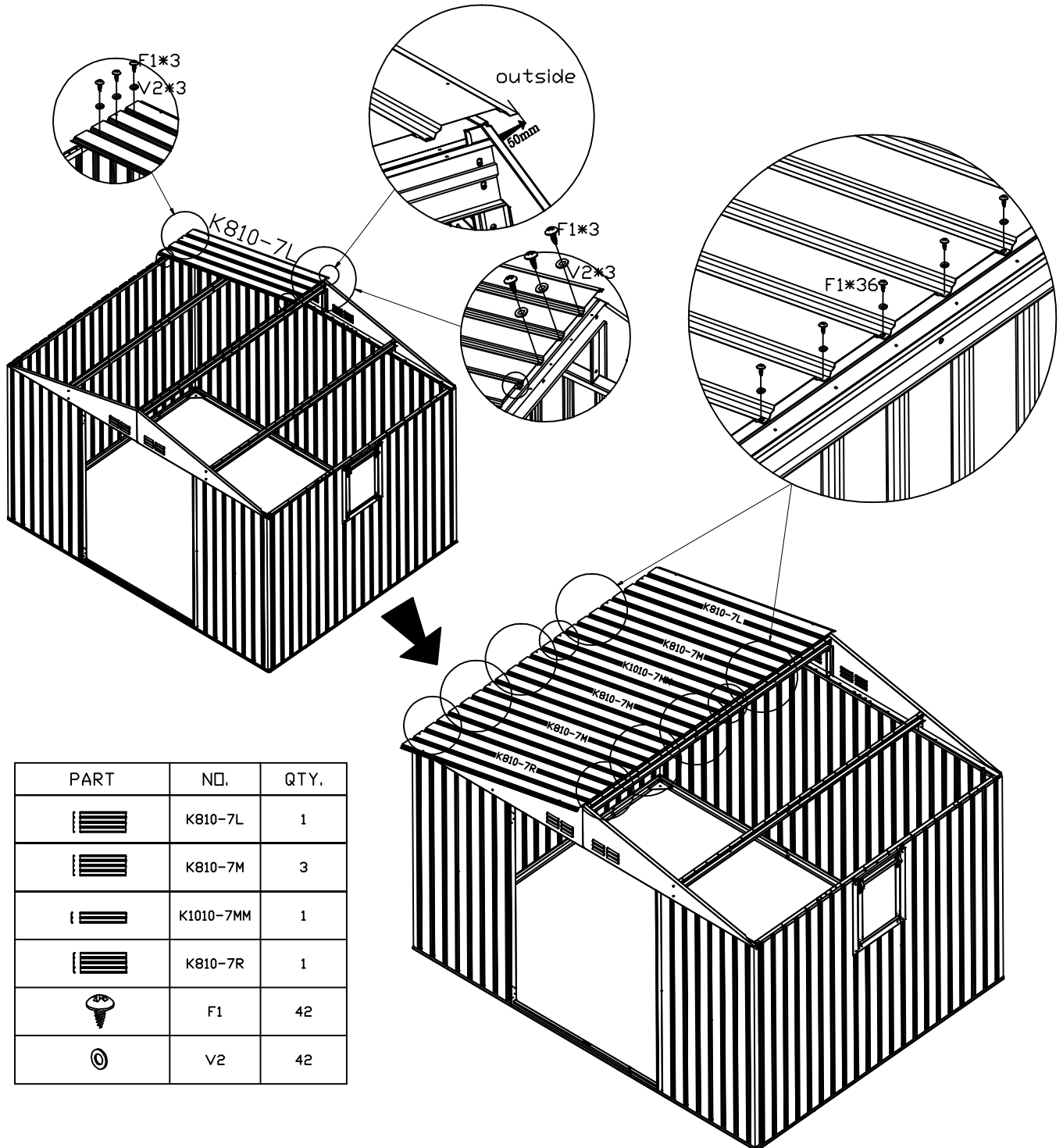



Install according to the diagram: The edge extends outward by about 50mm.

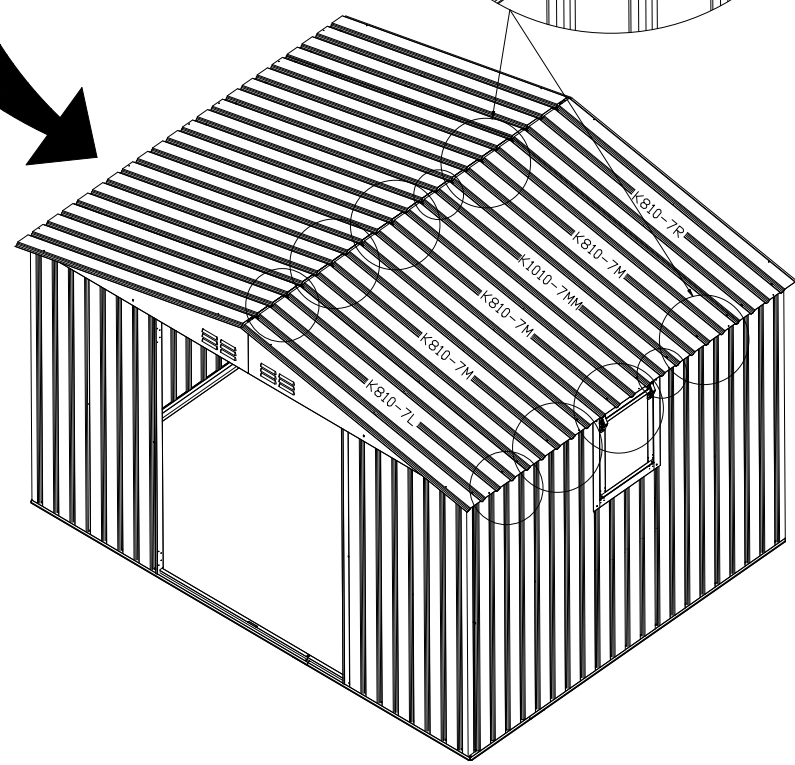
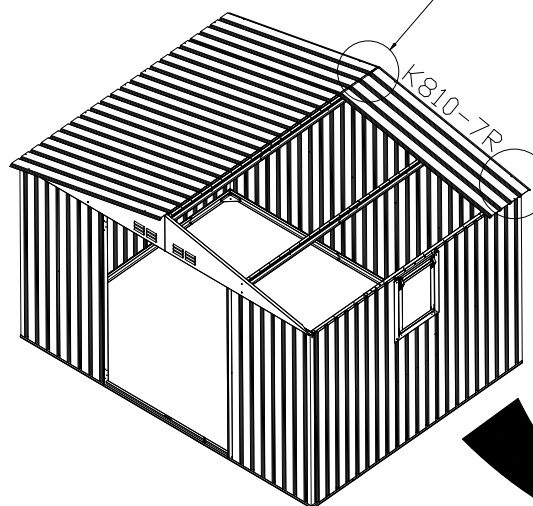
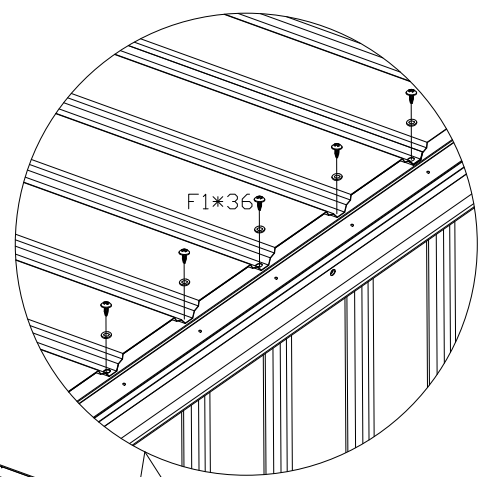
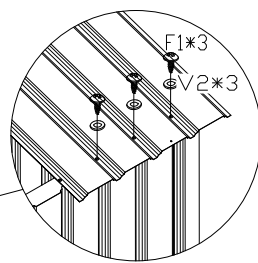
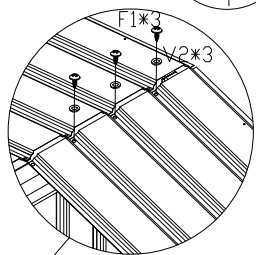
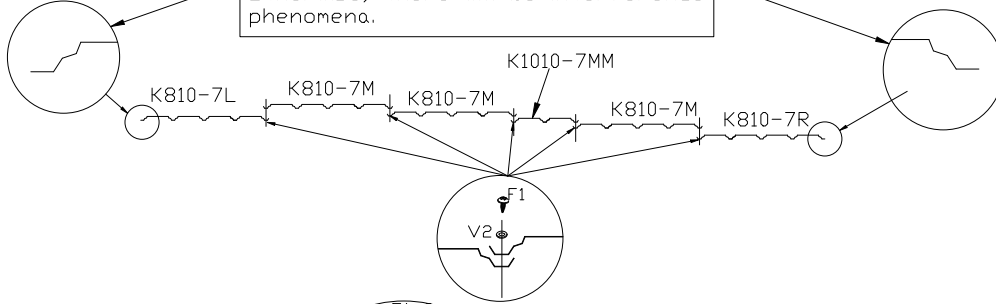





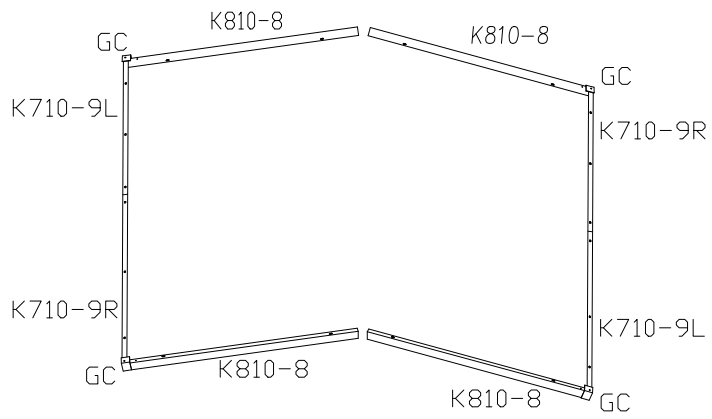

PART	NO.	QTY.
	K810-7L	1
	K810-7M	3
	K1010-7MM	1
	K810-7R	1
	F1	42
	V2	42

This is the installation of flat edges and K810-8, otherwise, there will be interference phenomena.







PART	NO.	QTY.
	K810-7L	1
	K810-7M	3
	K1010-7MM	1
	K810-7R	1
	F1	42
	V2	42

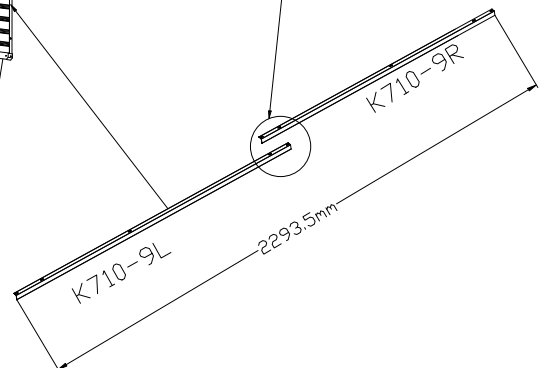
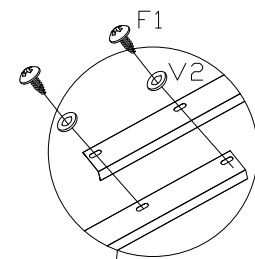
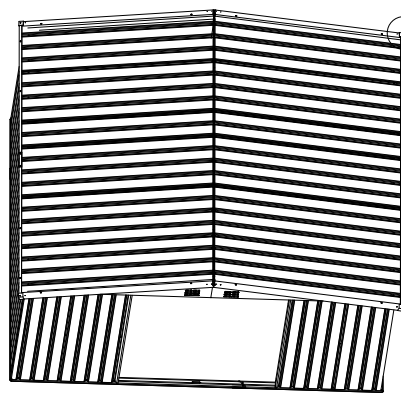
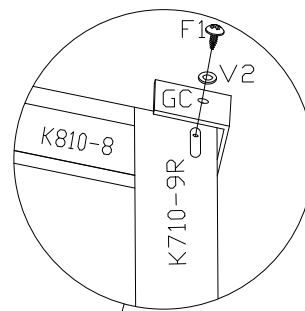
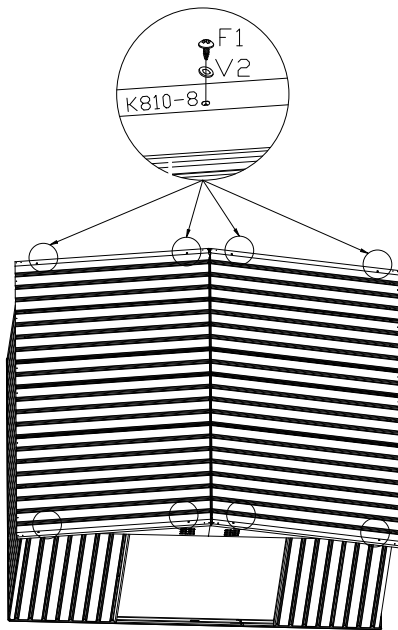

PART	NO.	QTY.
	K810-8	4
	K710-9L	2
	K710-9R	2
	GC	4
	F1	24
	V2	24



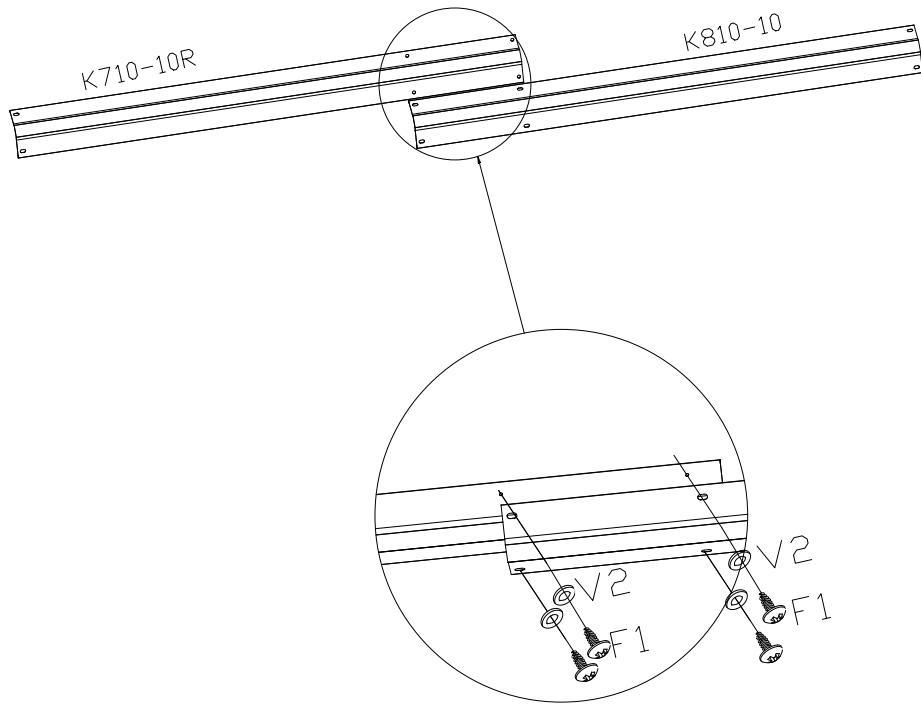
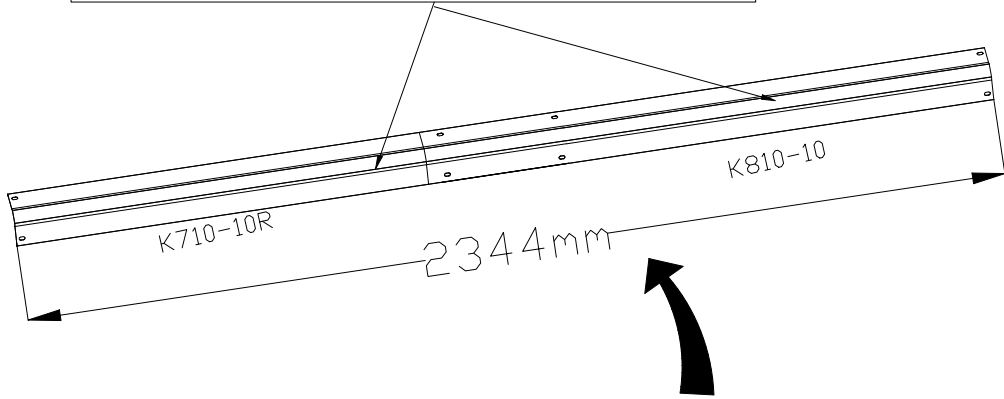

PART	NO.	QTY.
	K710-10R	1
	K810-10	1
	F1	4
	V2	4

According to the diagram, the two components of the roof rain shield should be connected with F1 self tapping screws before proceeding with subsequent installation.

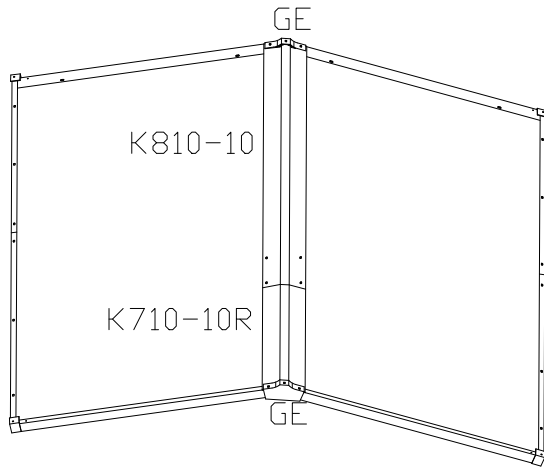



PART	NO.	QTY.
	GE	2
	F4	4
	V2	4

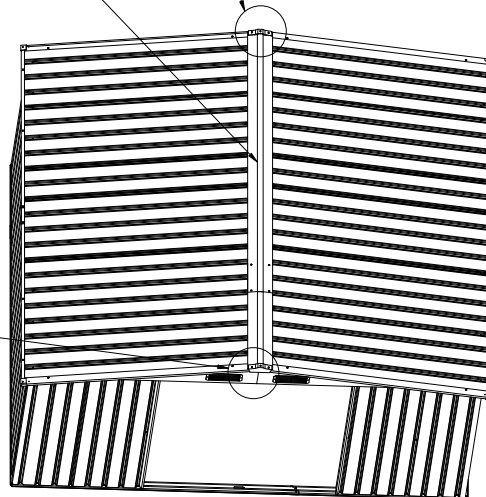
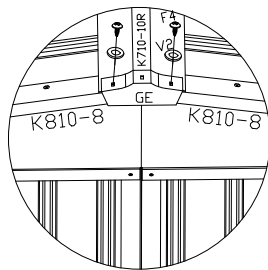
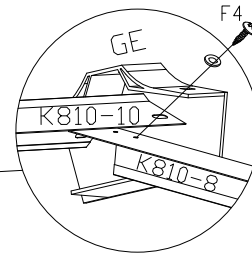
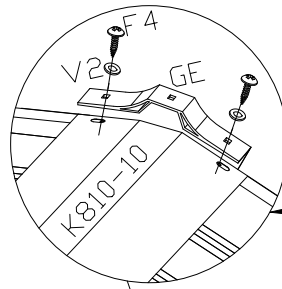
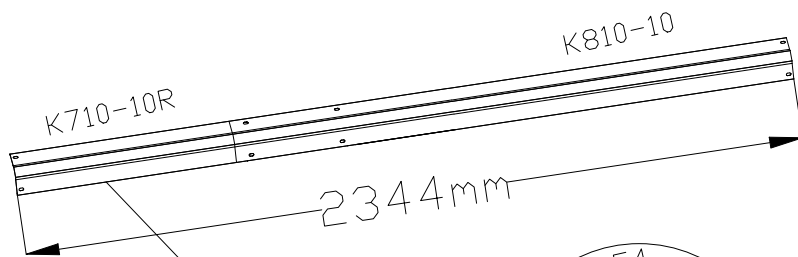

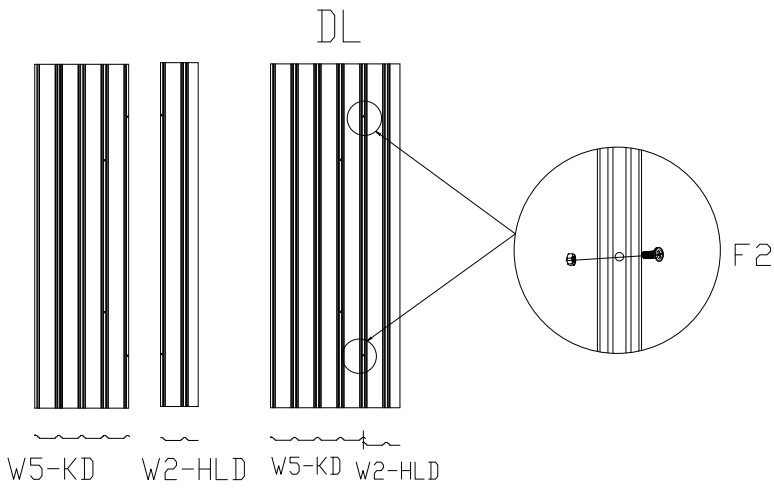

Left door panel splicing

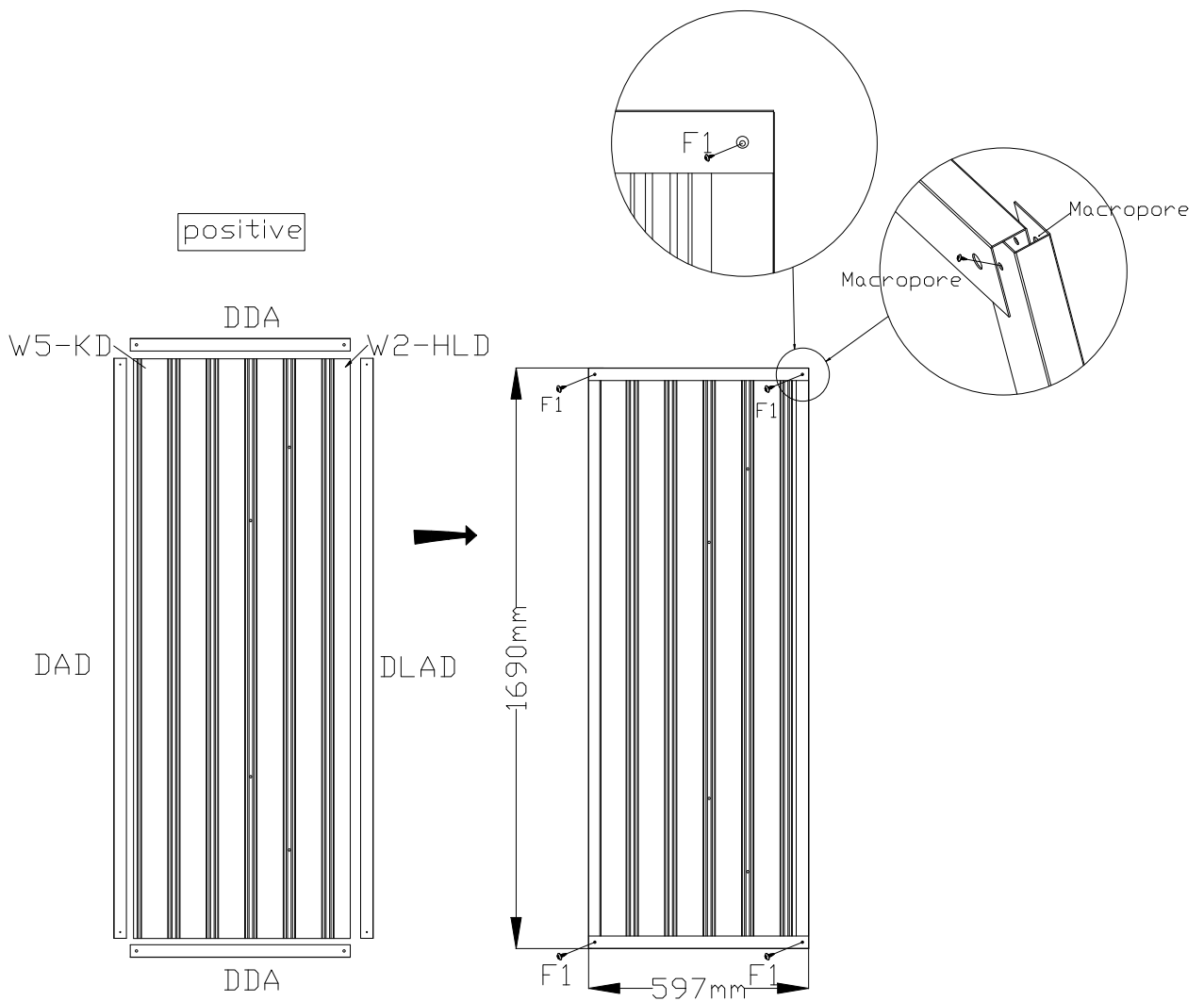

PART	NO.	QTY.
	W5-KD	1
	W2-HLD	1
	DAD	1
	DLAD	1
	DDA	2
	F1	4
	F2	2



Left door panel splicing

PART	NO.	QTY.
	DBD	2
	F1	5
	F2	2

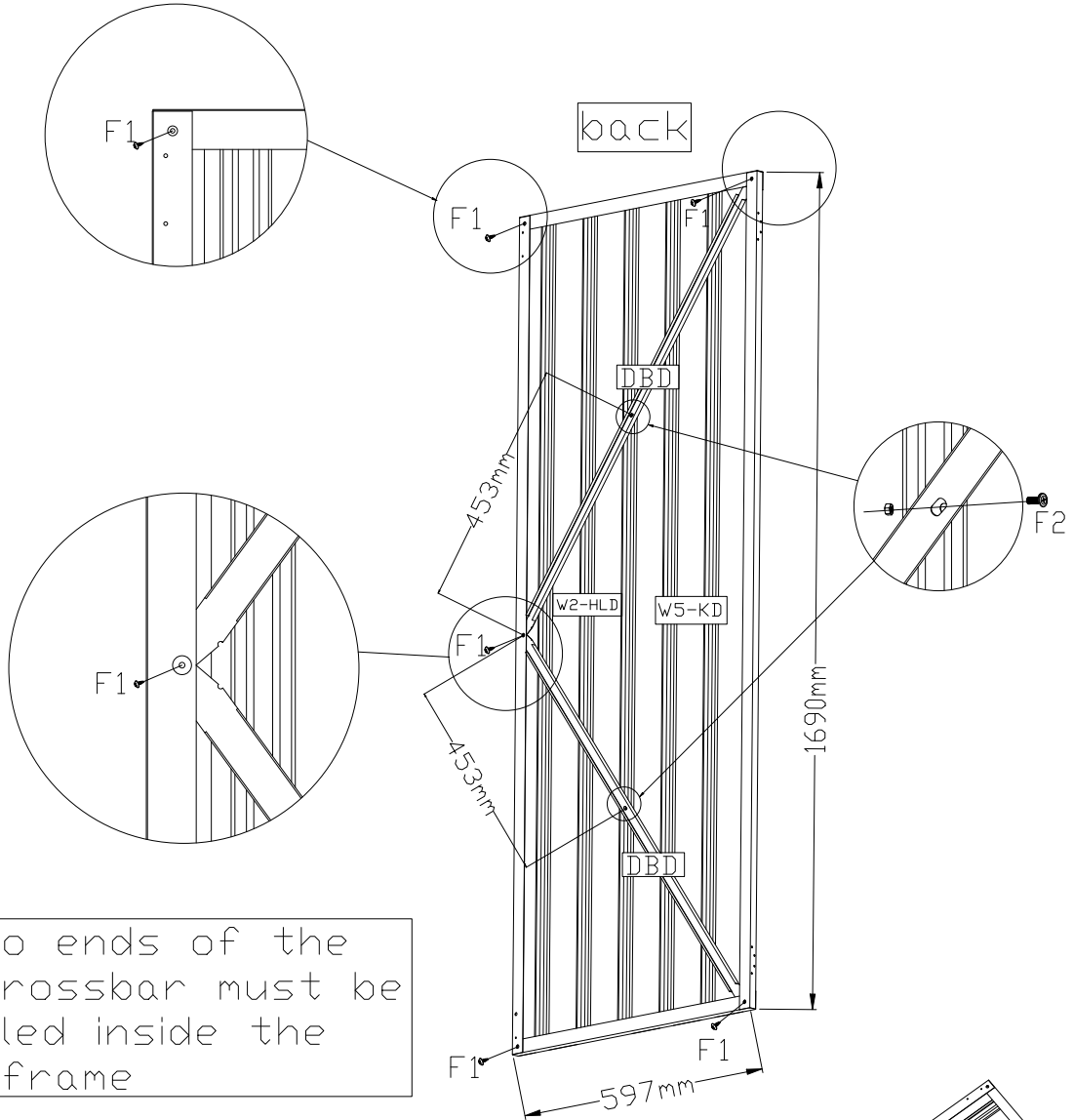

The two ends of the DBD crossbar must be assembled inside the door frame

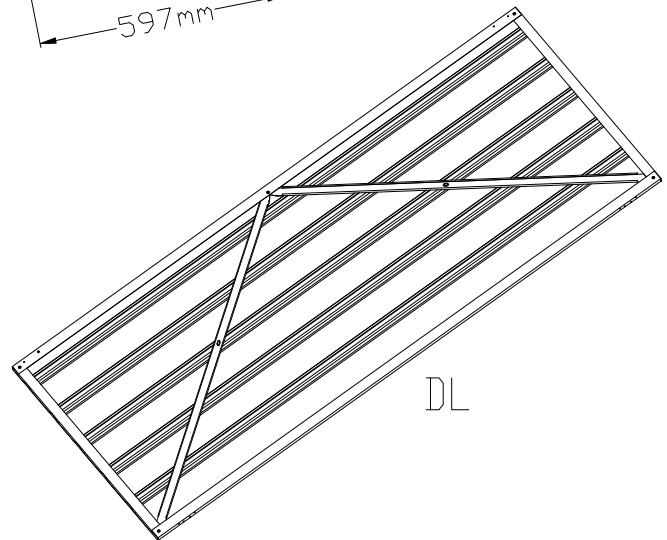

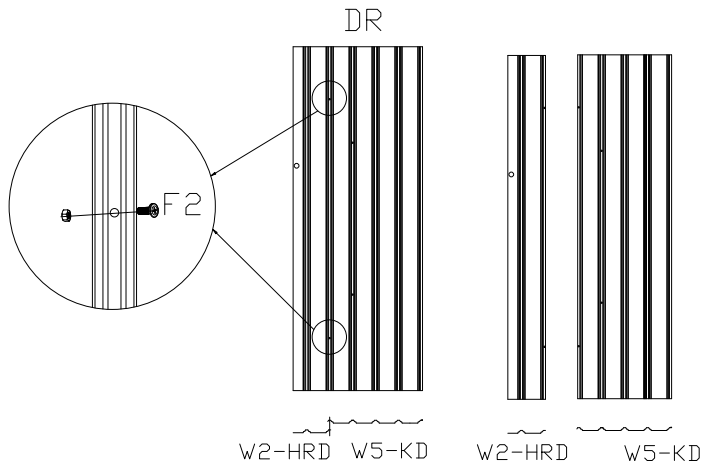

Right door panel splicing

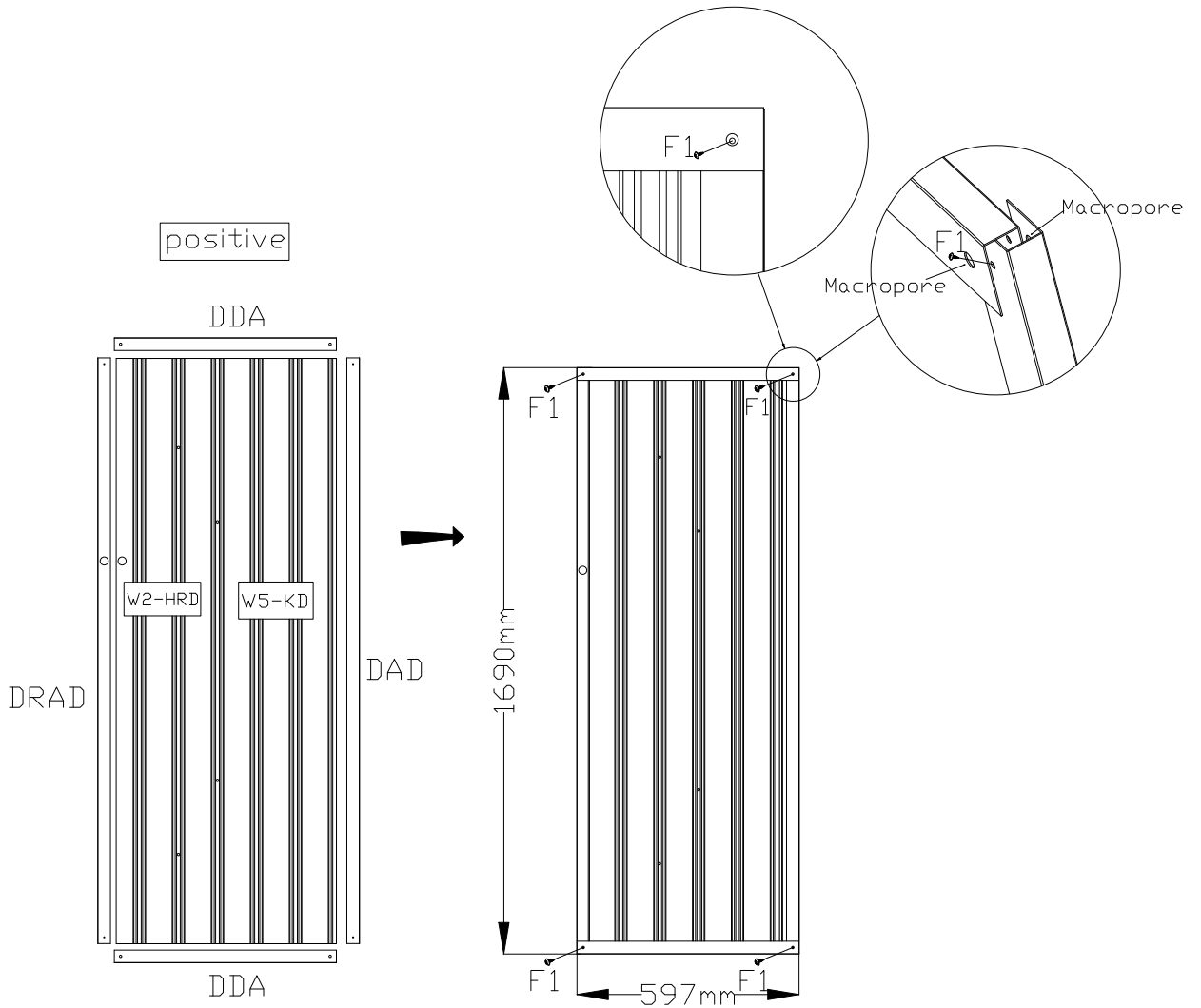

PART	NO.	QTY.
	W5-KD	1
	W2-HRD	1
	DAD	1
	DRAD	1
	DDA	2
	F1	4
	F2	2







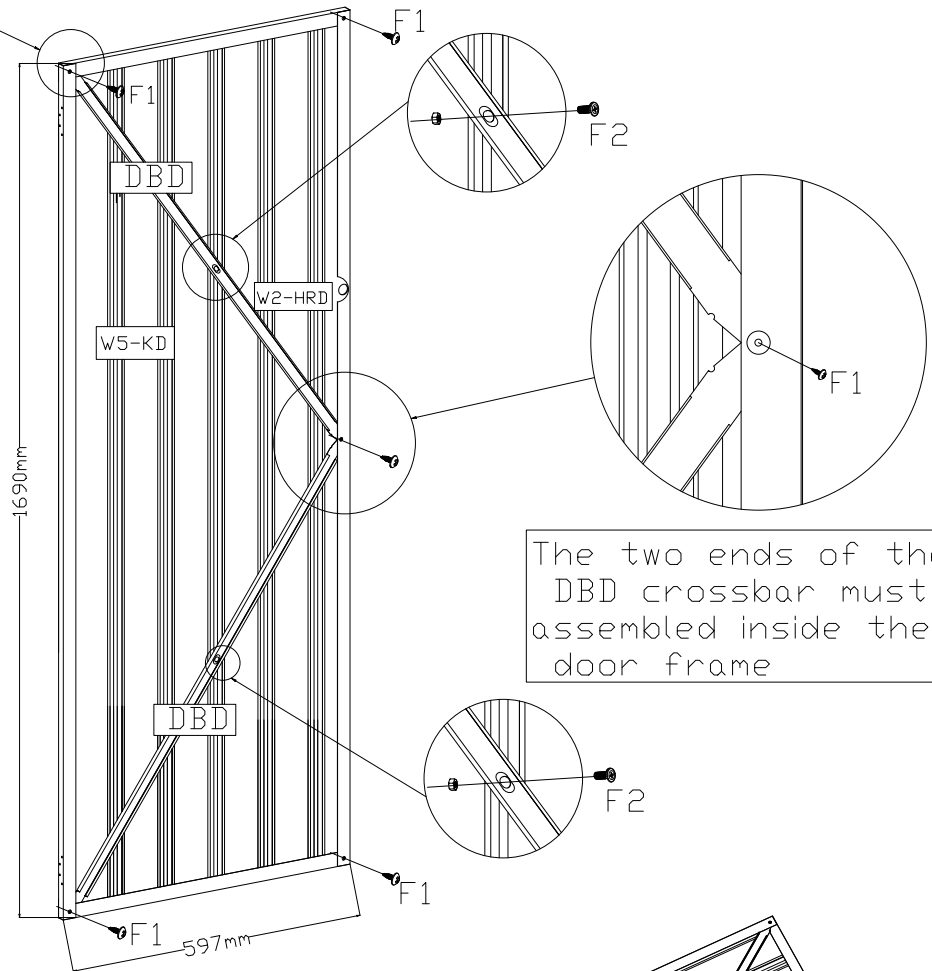
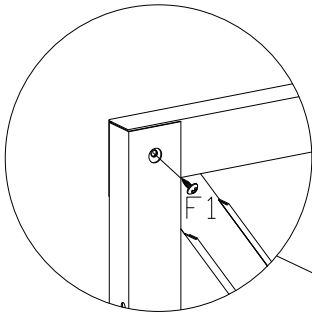

Right door panel splicing

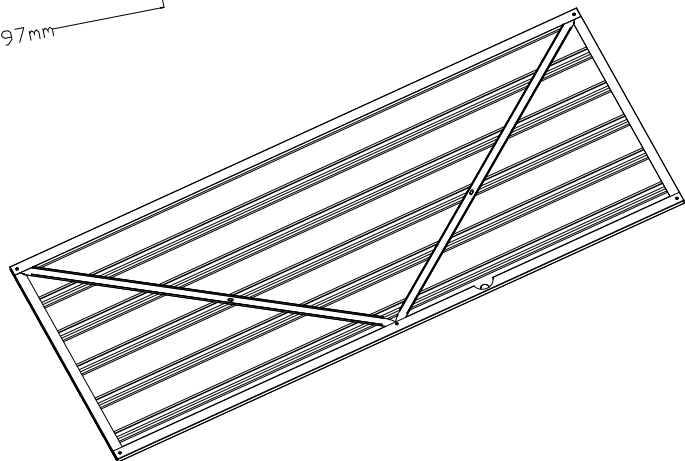
PART	NO.	QTY.
	DBD	2
	F1	5
	F2	2





The two ends of the DBD crossbar must be assembled inside the door frame

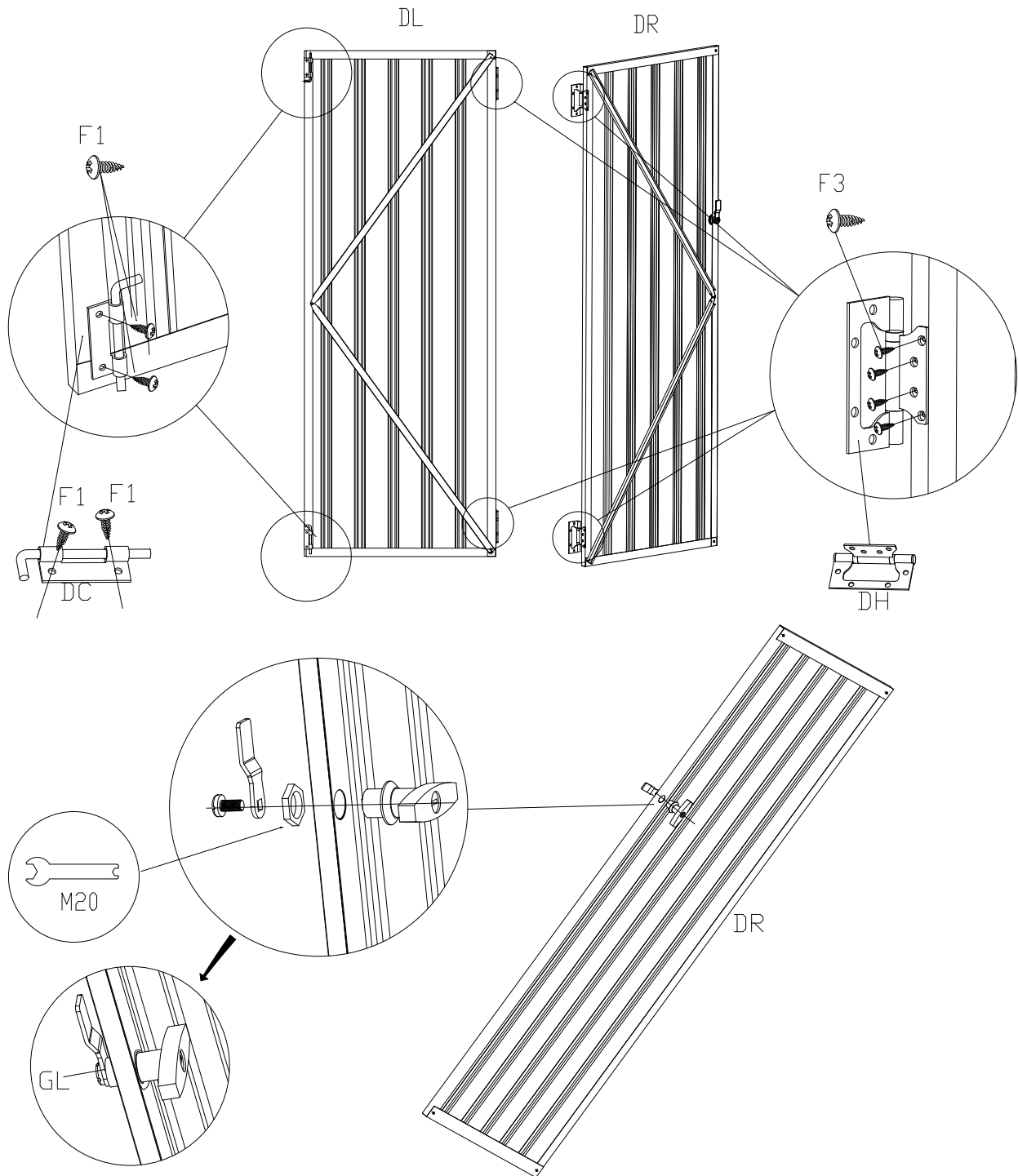

PART	NO.	QTY.
	DH	4
	DC	2
	F3	16
	GL	1
	F1	4



PART	NO.	QTY.
	DL	1
	DR	1
	F3	16

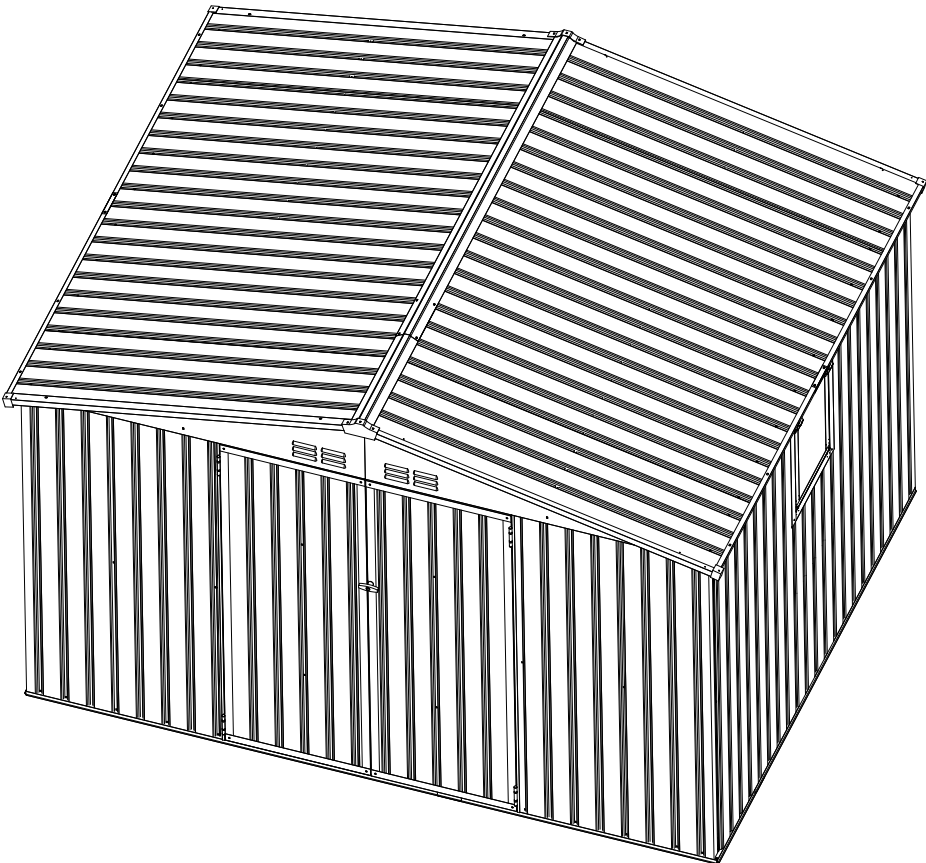
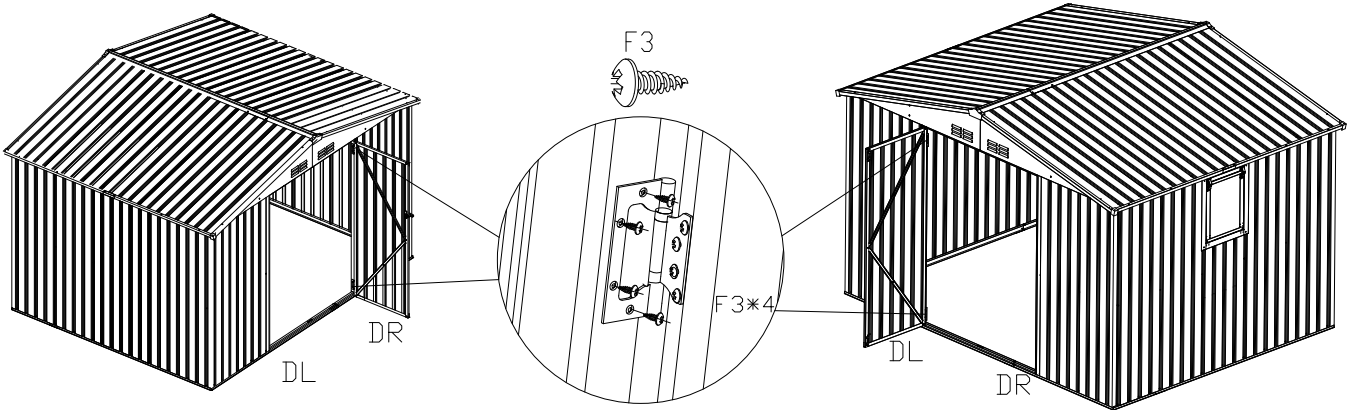

PART	NO.	QTY.
	SL	54

The exposed part of the assembly screw of the upper crossbeam support rod C4 needs to be covered with a plastic protective cap

The exposed part of the screws for assembling the upper crossbeam K710-6/K710-6R with the top cover needs to be covered with a plastic protective cap

