





Read this instruction carefully. See hardware and furniture part list for guidance. Be sure all parts are complete, before you assemble. Place all wooden furniture parts on a clean and flat soft surface to prevent from being scratched. Follow the figure to start assembling.

CAUTION : 1. Do not FULLY - TIGHTEN the nuts or nuts bolts until they are ready for assembly.
 2. Do not OVER - TIGHTEN the nuts or bolts to avoid causing damages to the thread.
 3. Keep all hardware parts out of reach of children.

NOTE : THE LIST AND QUANTITY SHOWN ARE FOR 1 UNIT ASSEMBLY.

Tools needed : Screwdriver (not provided).

PART LIST			
ITEM	DESCRIPTION	BOX	QTY
A	HEADBOARD	1	1 PC
B	FOOTBOARD	2	1 PC
C	SIDE RAIL	2	2 PCS
D	CENTER RAIL	2	2 PCS
E	CENTER SUPPORT LEG	2	6 PCS
F	CENTER SUPPORT	2	3 PCS
G	BED SLAT	2	39 PCS

HARDWARE LIST (BOX : 2)			
ITEM	DESCRIPTION		QTY
1	WOOD SCREW M4 x 20mm		4 PCS
2	WOOD SCREW M3.5 x 16mm		12 PCS
3	M5 ALLEN KEY (BALL SHAPE)		1 PC
4	BED SLAT SIDE FITTER		26 PCS
5	BED SLAT CENTER FITTER		26 PCS

STEP 1

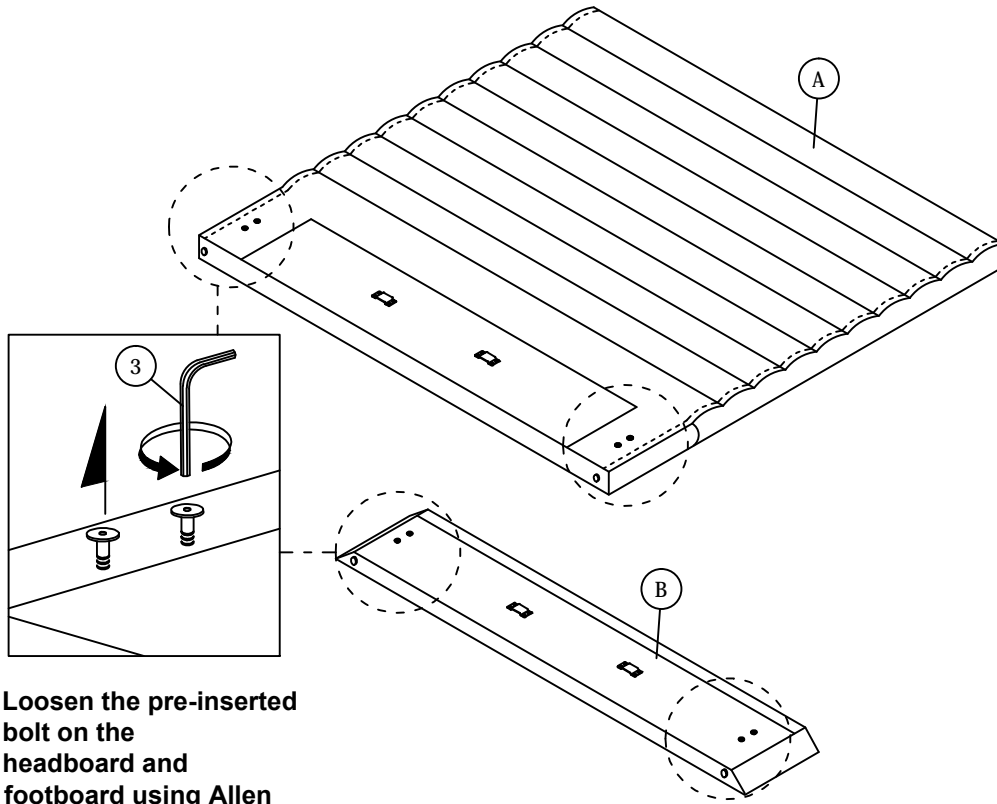

Loosen the pre-inserted bolt on the headboard and footboard using Allen key ball shape (3).

STEP 2

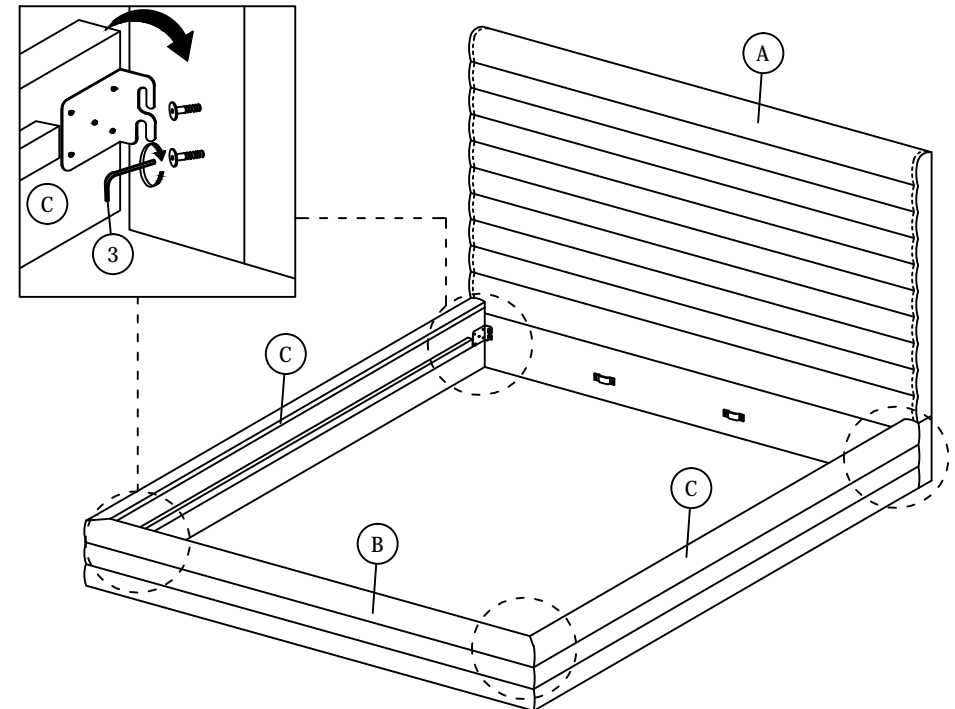

ASSEMBLY INSTRUCTIONS

STEP 3

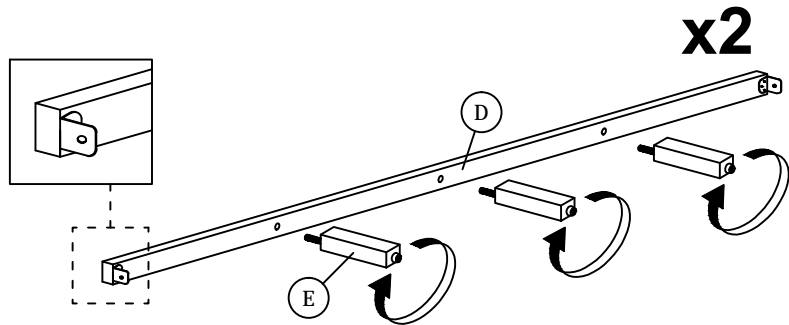

STEP 4

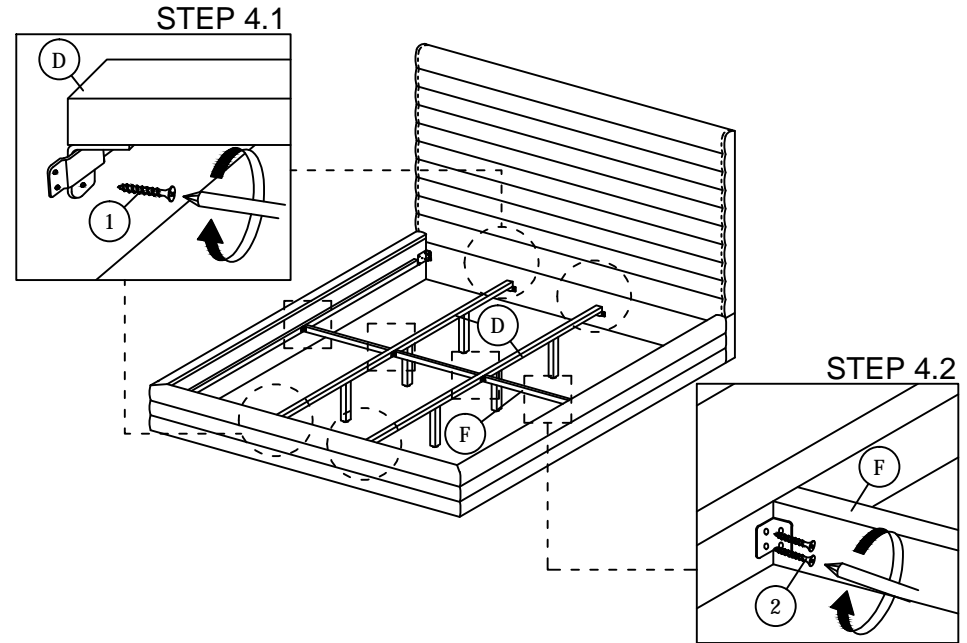

STEP 5

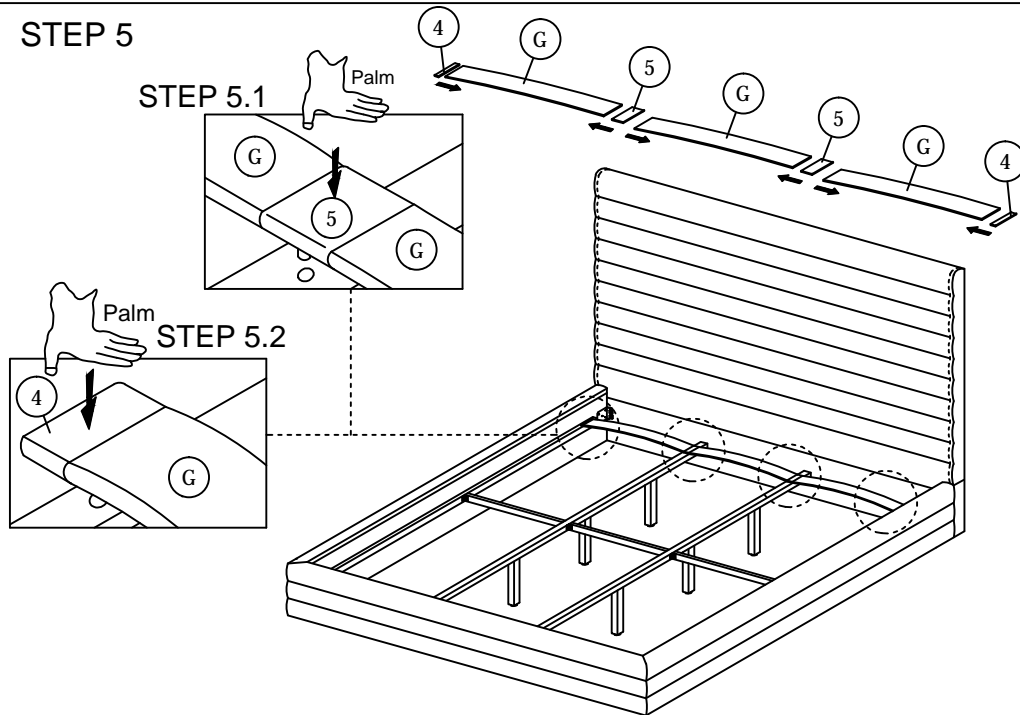

STEP 6

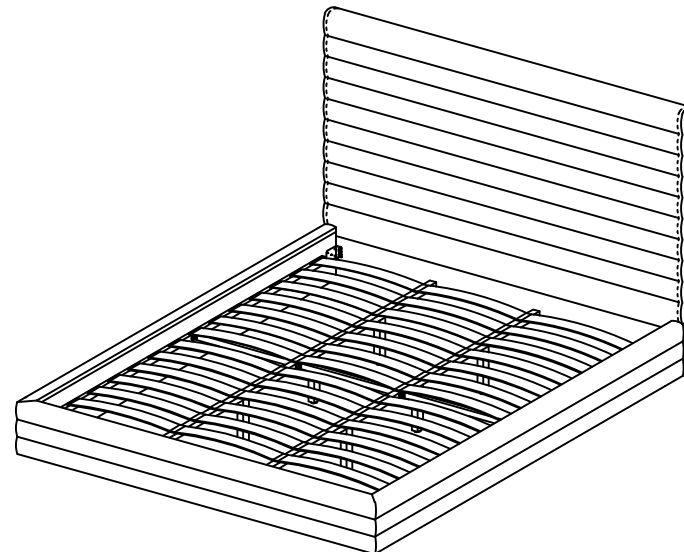

* When moving the bed position, the center support legs must be adjust to be straight to avoid any broken problem.

MODEL : BBT 3224.11 A1 NIGHTSTAND ASSEMBLY INSTRUCTIONS

Read this instruction carefully. See hardware and furniture part list for guidance. Be sure all parts are complete, before you assemble. Place all wooden furniture parts on a clean and flat soft surface to prevent from being scratched. Follow the figure to start assembling.

CAUTIONS : 1. Do not FULLY - TIGHTEN the nut or nut bolt until all nut or bolt is ready assembled.
 2. Do not OVER - TIGHTEN the nut or bolt to avoid causing damages to the thread.
 3. Keep all hardware parts out of reach of children.

NOTE : THE LIST AND QUANTITY SHOWN ARE FOR 1 UNIT ASSEMBLY.

Tool needed : Screwdriver (not provider).

PART LIST			
ITEM	DESCRIPTION	BOX	QTY
A	BODY	1	1 PC
B	HANDLE	1	2 PCS
C	HANDLE SCREW	1	4 PCS
D	FLAT WASHER	1	4 PCS
E	DRAWER	1	2 PCS

HARDWARE LIST		
ITEM	DESCRIPTION	QTY
-	-	-

STEP 1

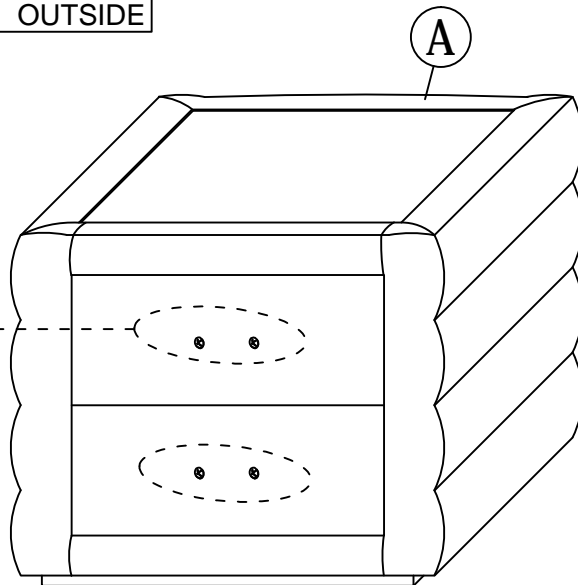
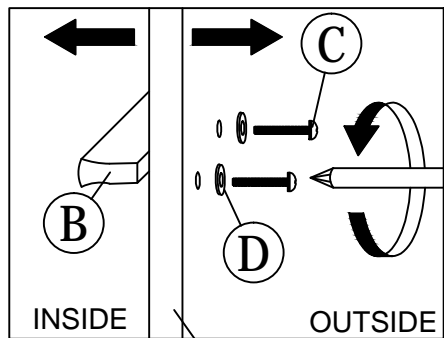

STEP 2

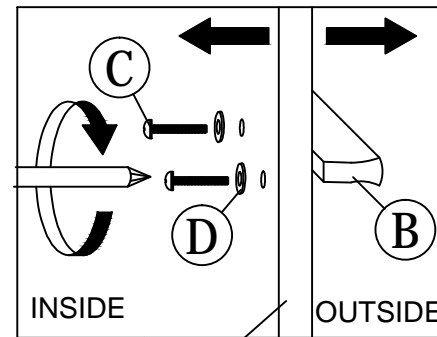

Note :
 Hold the handle flat and then tighten the screws

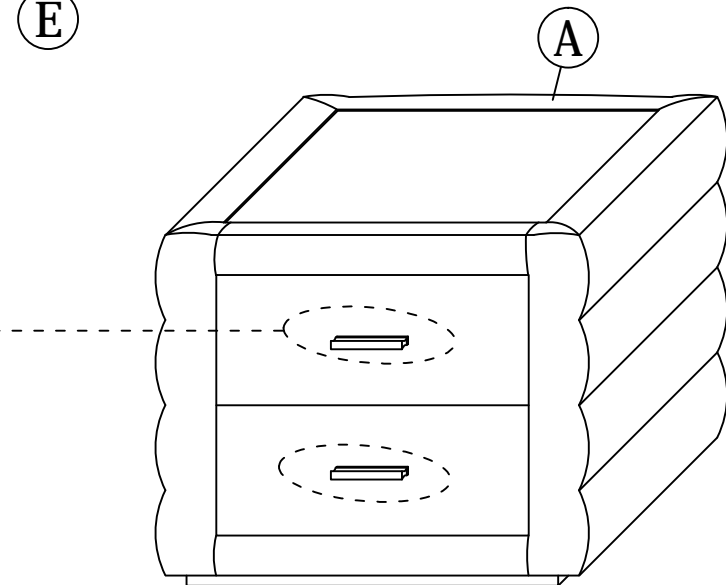

ASSEMBLY INSTRUCTIONS

STEP 3

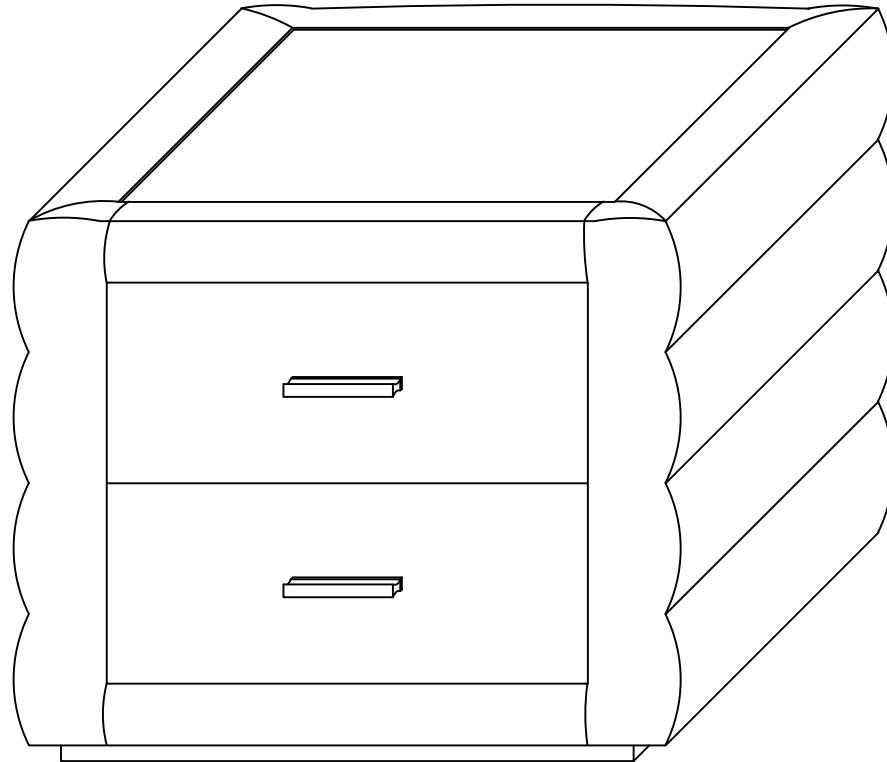

Read this instruction carefully. See hardware and furniture part list for guidance. Be sure all parts are complete, before you assemble. Place all wooden furniture parts on a clean and flat soft surface to prevent from being scratched. Follow the figure to start assembling.

CAUTIONS :

1. Do not FULLY - TIGHTEN the nut or nut bolt until all nut or bolt is ready assembled.
2. Do not OVER - TIGHTEN the nut or bolt to avoid causing damages to the thread.
3. Keep all hardware parts out of reach of children.

NOTE : THE LIST AND QUANTITY SHOWN ARE FOR 1 UNIT ASSEMBLY.
Tool needed : Screwdriver (not provided).

PART LIST			
ITEM	DESCRIPTION	BOX	QTY
A	BODY	1	1 PC
B	HANDLE	1	6 PCS
C	HANDLE SCREW	1	12 PCS
D	FLAT WASHER	1	12 PCS
E	DRAWER	1	6 PCS

HARDWARE LIST		
ITEM	DESCRIPTION	QTY
-	-	-

STEP 1 Note : Open the last of drawer and take out all the parts.

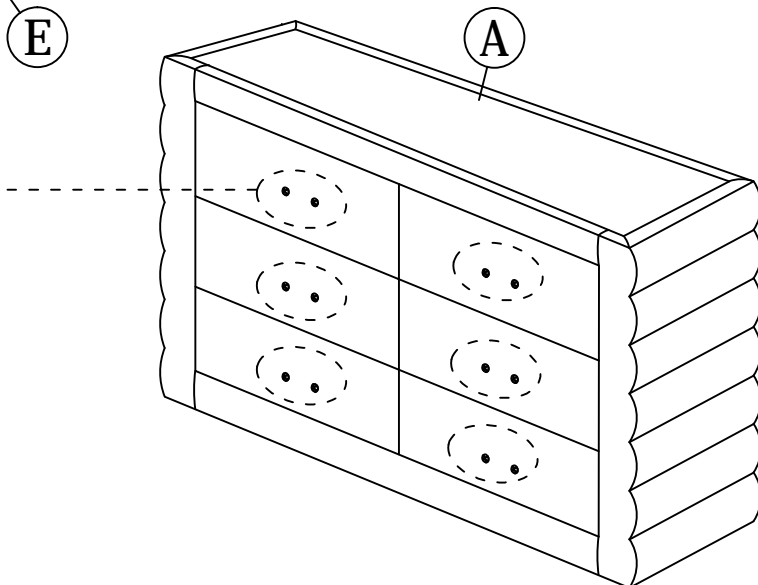
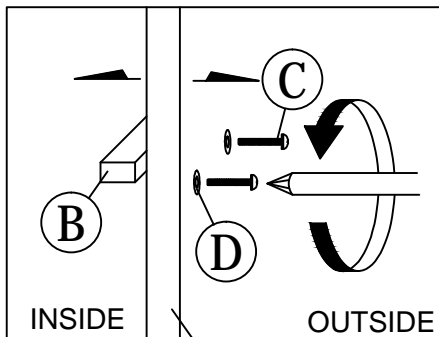

STEP 2

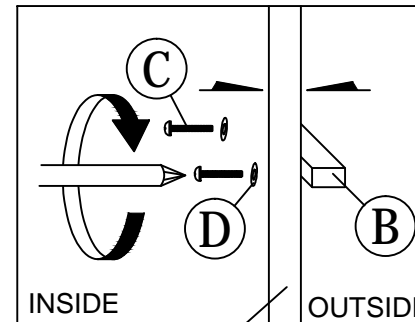

Note :
Hold the handle flat and then tighten the screws

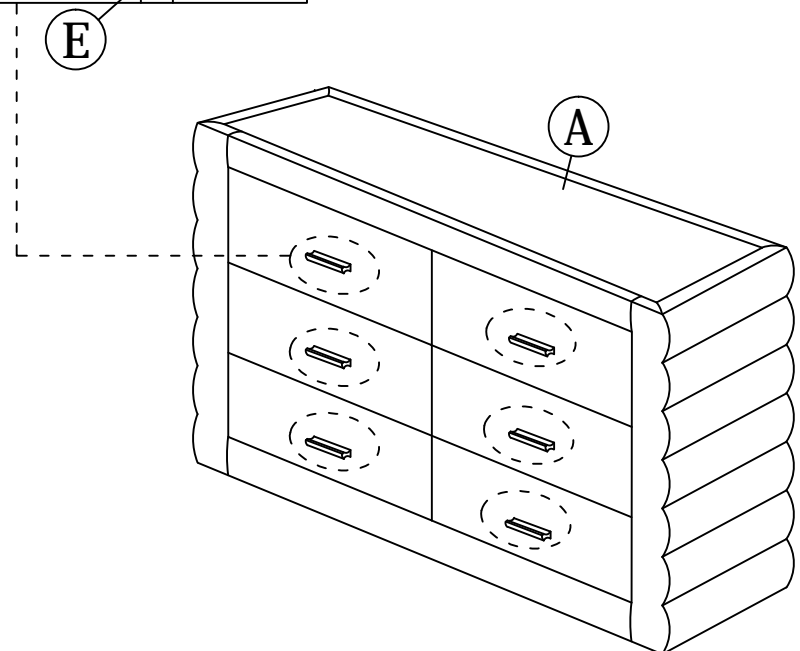

ASSEMBLY INSTRUCTIONS

STEP 3

