

















CARE AND MAINTENANCE

Wipe clean with a soft, dry cloth. The seat board can be cleaned with a mild cleaner. Test the cleaning method on a hidden area before using them over the entire area.

NOTICE

- * Please make sure that you have all parts indicated before you begin assembly of this item.
- * This item should be assembled on a soft surface to prevent scratching the finished product during assembly.
- * This item may require periodic tightening.
- * Do not tighten bolts until completely assembled.

Part List and Hardware List

Piece	Description	Picture	Quantity
A	HEADBOARD		1X
B	L-POST		1X
C	R-POST		1X
D	FOOTBOARD		1X
E	SUPPORT LEGS OF SLATS		8X
F	SUPPORT LEGS OF RAILS		2X
G	SLAT		4X
H	L-RAIL		2X
I	R-RAIL		2X
J	WOOD LEG		2X
K	WOOD BAR		2X
H1	BOLT 5/16"*2-1/2"		12X
H2	BOLT 1/4"*2"		10X
H3	ALLEN KEY 4mm		1X
H4	SCREW ø8*30mm		8X
H5	SCREW ø8*15mm		8X
H6	METAL PLATE 50*33*1mm		2X

Product Dimensions:82-3/4"W*58-1/2"D*58-1/4"H

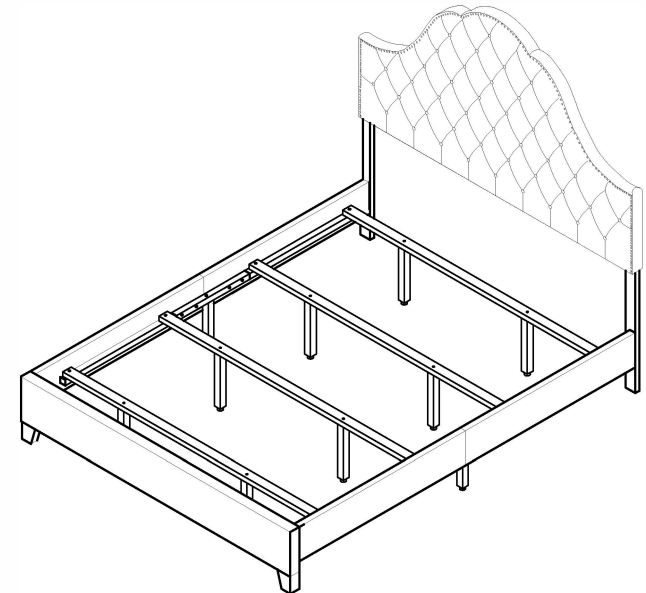

Weight capacity : 550lbs
WARNING : DO NOT STAND ON THE BED

PREPARATION

Before beginning assembly of product, make sure all parts are present. Compare parts with package contents list and hardware contents list. If any part is missing or damaged, do not attempt to assemble the product.

Estimated Assembly Time: 15 minutes.

Tools Required for Assembly (included): Wrench.

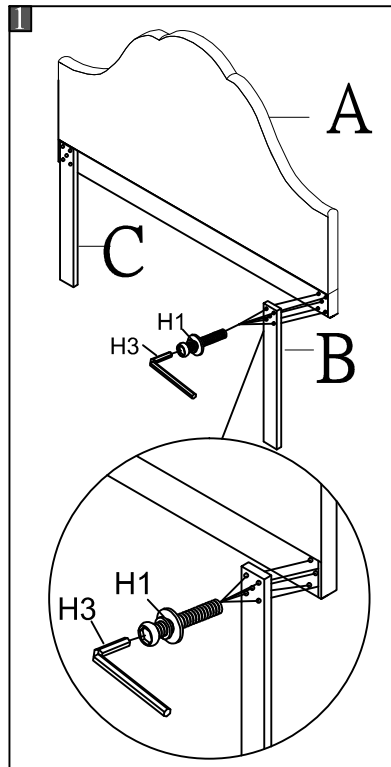

Step 1

Attach L/R posts "B" & "C" to headboard "A" by using Allen key (H3) to lock with bolts "H1".

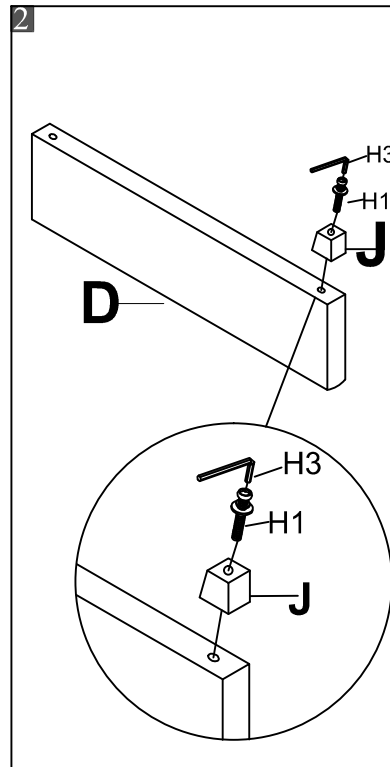

Step 2

Attach wood legs "J" with footboard "D". Using Allen key (H3) to lock with bolts "H1".

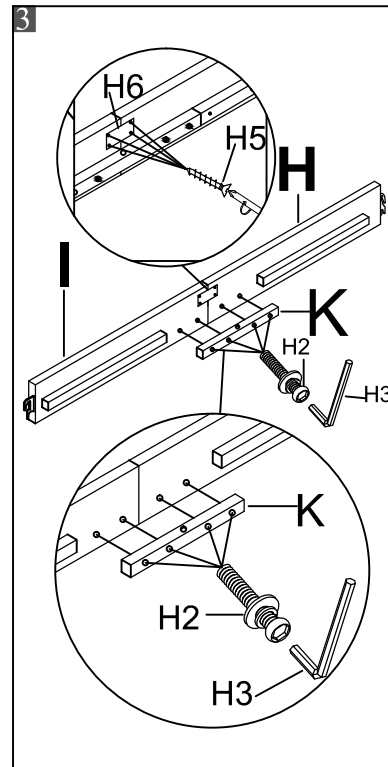

Step 3

Attach wood bar "K" to the 2 rails "H" & "I". Using Allen key (H3) to lock with bolts "H2". Lock the both side rails (H & I) (front & rear of rail) tight and alignment with metal plate (H6) by using 8x screws (H5)

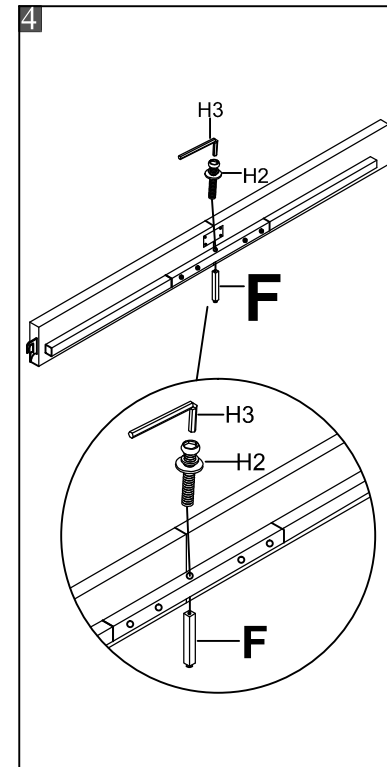

Step 4

Attach support legs "F" to wood bar "K". Using Allen key (H3) to lock with bolts "H2".

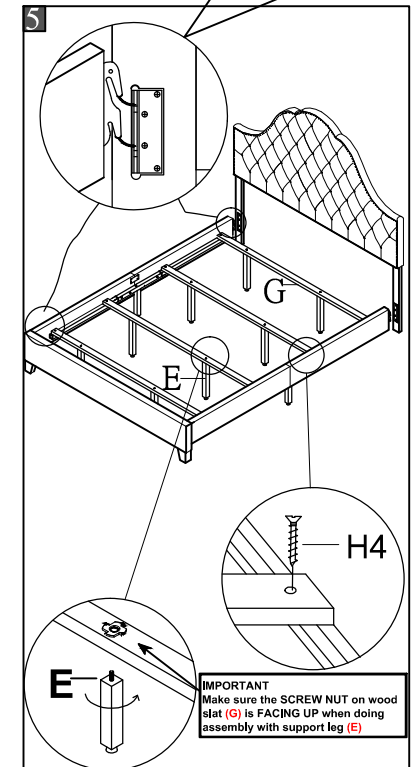

Step 5

Attach 2 rails to the L/R posts & the footboard assembled with legs. Attach 2 support legs (E) to each slat (G). Lock the slats tight with wood bar (both inside of rails) by using 8x screws (H4).

Important:
For correct assembly please ensure the double hooks are latched properly.

IMPORTANT
Make sure the SCREW NUT on wood slat (G) is FACING UP when doing assembly with support leg (E)

















CARE AND MAINTENANCE

Wipe clean with a soft, dry cloth. The seat board can be cleaned with a mild cleaner. Test the cleaning method on a hidden area before using them over the entire area.

NOTICE

- * Please make sure that you have all parts indicated before you begin assembly of this item.
- * This item should be assembled on a soft surface to prevent scratching the finished product during assembly.
- * This item may require periodic tightening.
- * Do not tighten bolts until completely assembled.

Part List and Hardware List

Piece	Description	Picture	Quantity
A	HEADBOARD		1X
B	L-POST		1X
C	R-POST		1X
D	FOOTBOARD		1X
E	SUPPORT LEGS OF SLATS		8X
F	SUPPORT LEGS OF RAILS		2X
G	SLAT		4X
H	L-RAIL		2X
I	R-RAIL		2X
J	WOOD LEG		2X
K	WOOD BAR		2X
H1	BOLT 5/16"*2-1/2"		12X
H2	BOLT 1/4"*2"		10X
H3	ALLEN KEY 4mm		1X
H4	SCREW ø8*30mm		8X
H5	SCREW ø8*15mm		8X
H6	METAL PLATE 50*33*1mm		2X

Product Dimensions:88-3/4"W*64-1/2"D*58-1/4"H

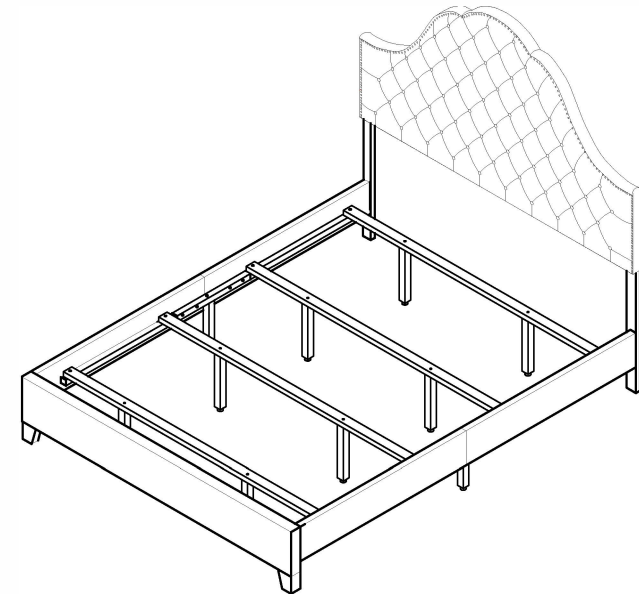

Weight capacity : 550lbs
WARNING : DO NOT STAND ON THE BED

