

EN: Reinforce the cage (or fence) with the cable ties after finishing the assembling.

DE: Verstärken Sie den Käfig (oder den Zaun) mit den Kabelbindern, nachdem Sie den Zusammenbau beendet haben.



IT: Rinforzare la gabbia (o il recinto) con delle fascette dopo aver finito l'assemblaggio.

ES: Una vez finalizado el montaje, refuerce la jaula (o la valla) con las bridas.

FR: Renforcez la cage (ou la clôture) avec les attaches de câble après avoir terminé l'assemblage.

READ AND SAVE THIS INSTRUCTIONS FOR FUTURE USE

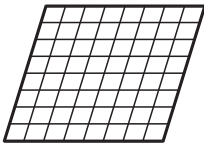
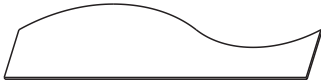
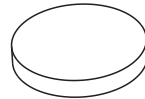
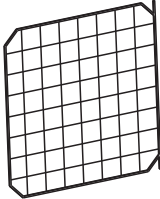
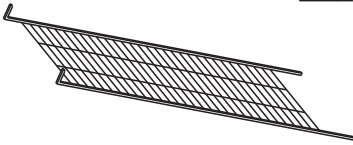
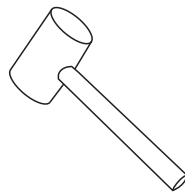
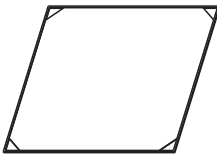
ASSEMBLY & INSTRUCTION MANUAL

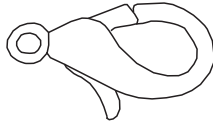
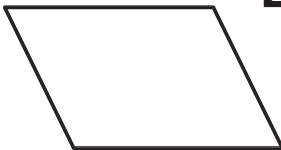
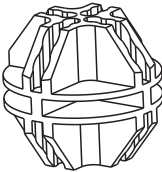
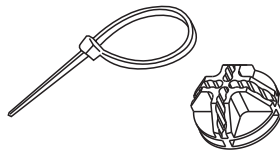
	A x28		E x 9		I x12
	B x 2		F x 1		J x 1
	C x10		G x42		K x 2
	D x 4		H x 3		L

