

ASSEMBLY INSTRUCTIONS - Power Recliners Sofa

ITEM # 8097-SOFA / 8098-SOFA / 8099-SOFA

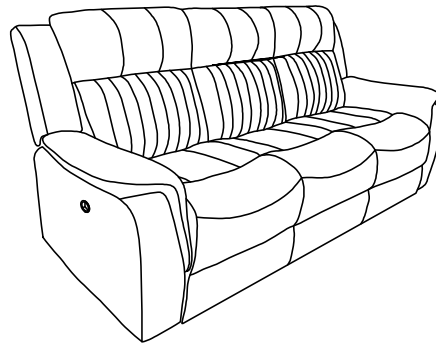

- Read this instructions carefully.
- See part list for guidance. Be sure all parts are complete before you assemble.
- Place all wooden furniture parts on a clean and flat soft surface to prevent from being scratched.
- Follow the figure to start assembling. All instructions must be followed in order to be assembled correctly.
- Minimum of 2 people are required for assembly.

PART LIST

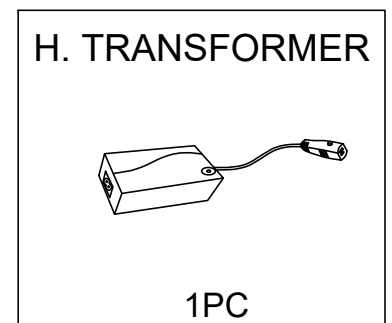
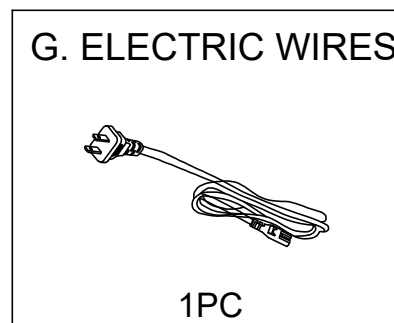
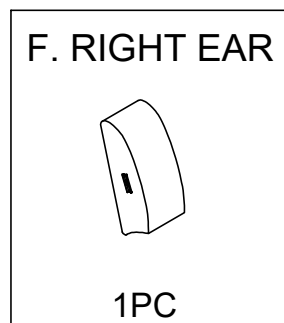
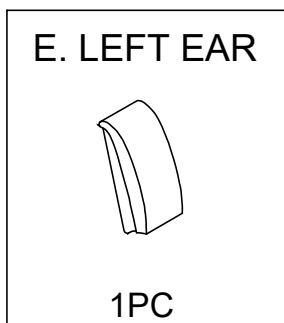
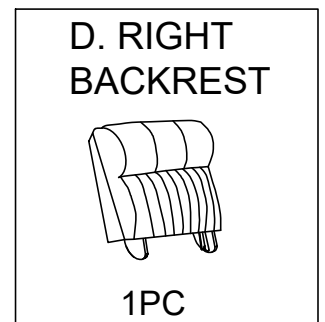
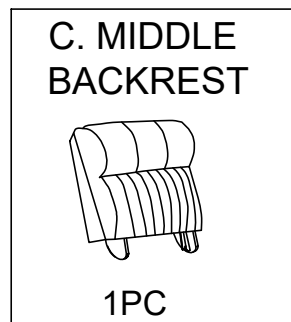
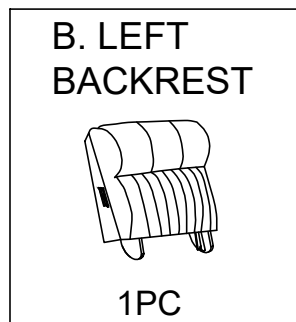
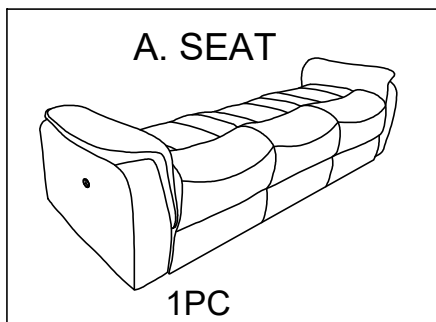

ATTENTION:

1. THE LIST AND QUANTITY SHOWN ARE FOR 1 UNIT ASSEMBLY.
2. EACH BOX CONTAINS CONNECTING COMPONENTS PIECES TOGETHER.
3. DO NOT MIX COMPONENTS FROM OTHER BOX!
4. ASSEMBLE EACH PART IN EACH BOX SEPARATELY.
5. DO NOT CONNECT THE WHOLE SECTIONAL UNTIL EACH PART IS INDIVIDUALLY ASSEMBLED.

ITEM # 8097-SOFA / 8098-SOFA / 8099-SOFA

Step1. Attach the Left backrest (B) Middle backrest (C) and Right backrest (D) to seat (A) by aligning the metal backrest and press them down from the top until you hear a click sound on each side meaning it is thoroughly connected

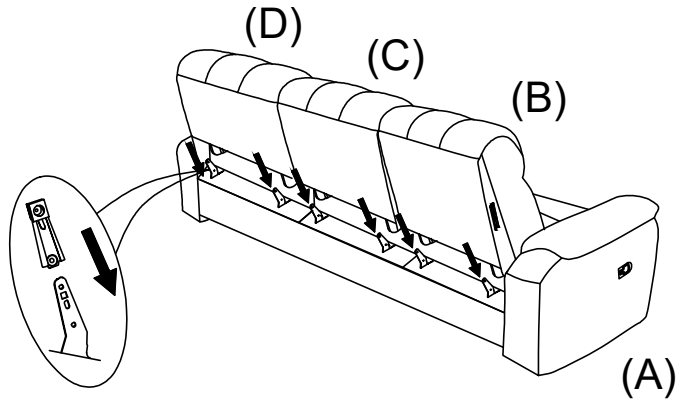

Step2. Attach the Left Ear (E) to the left side of Left backrest (B) and Right Ear (F) to the right side of Right backrest (D) by sliding the metal slot on the Ear down onto the side of the Backrest

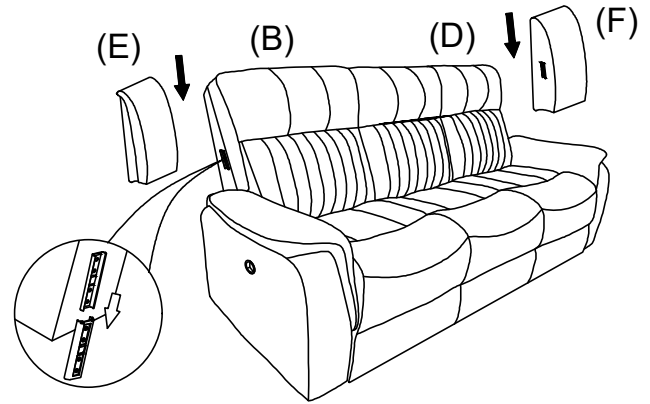

Step 3: Find the electric wires in the back of Seat(A) . Attach the transformer (H) to the wires by inserting the pin into the small socket on the transformer. Attach the transformer (H) to the chair by inserting the pin into the small socket on the back of Seat (A) .

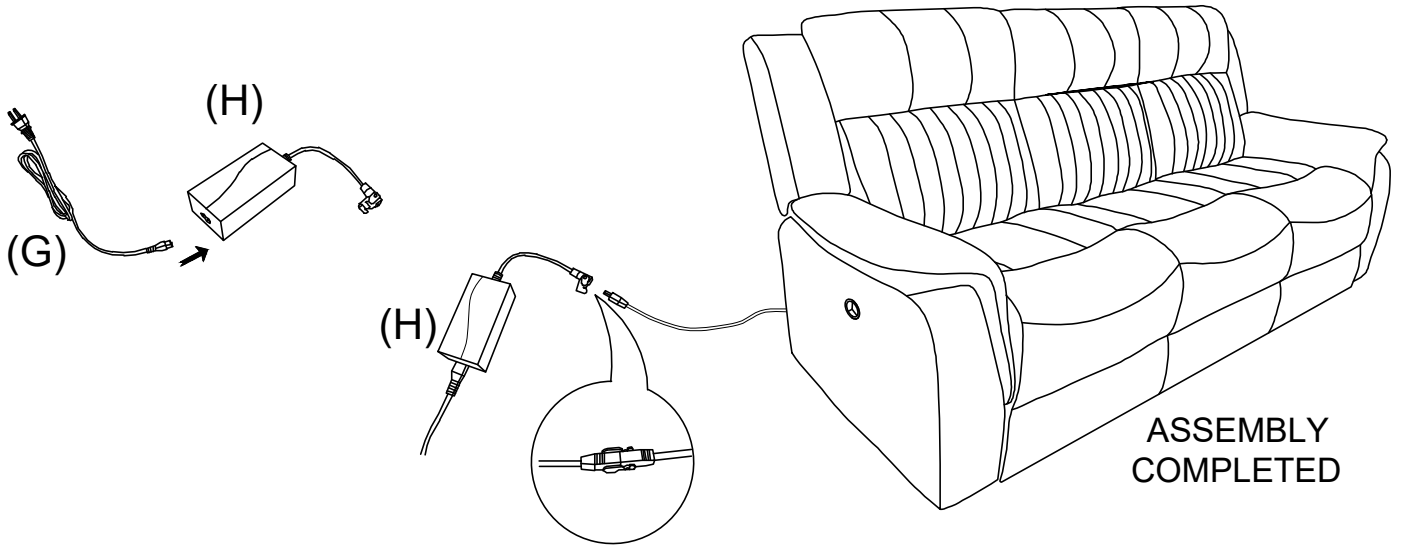

Step 4: To recline the Left/Right Backrest (B/D) and raise Left/Right Footrest on Seat (A) by pressing the button on the side of Seat (A)

