

NOTICE

- * Please make sure that you have all parts indicated and they are in good condition before you begin assembly of this item. Refer to part list and hardware list below for guidance.
- * This item should be assembled on a soft surface to prevent scratching the finish during assembly.
- * This item may require periodic tightening.
- * If you are having difficulty, our friendly Customer Care team is always here to help.

PREPARATION

- * Before beginning assembly of product, make sure all parts are present. Compare parts with part contents list and hardware contents list.
- * If any part is missing, do not attempt to assemble the product.
- * Estimated Assembly Time: 10 minutes.
- * Tools Required for Assembly (included): Allen Key

CARE AND MAINTENANCE

WOOD CARE





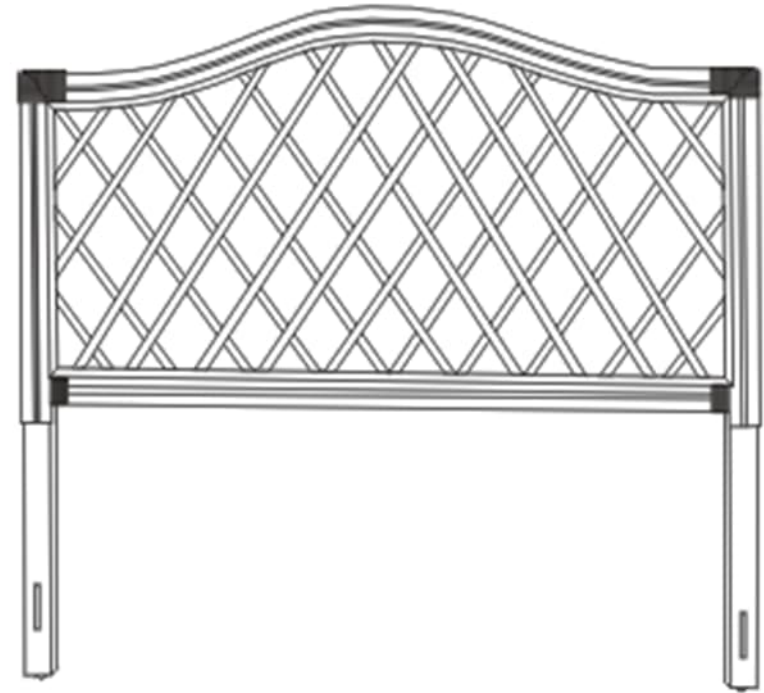

Adhesive felt pads should always be applied to areas of furniture which make direct contact with flooring, said application will prevent damage to the furniture and or surfaces on which the furniture lies. Objects placed on articles of furniture should rest on nonabrasive material as to prevent damage to the wood finish. Wipe up spills immediately and avoid common hazards such as hot dishes, harsh solvents and abrasives. Cleaning should be done with a soft lint free cotton cloth dampened with water or furniture polish.

Owner Manual

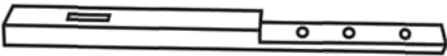
ITEM DIMENSIONS : 61.4"W x 3"D x 55.1"H



Part List and Hardware List

PIECE	DESCRIPTION	PICTURE	QUANTITY
A	HEADBOARD		1X
B	WOODEN LEG		2X
HW1	BOLT 8X50		6X
HW2	BOLT 8X60		4X
HW3	WASHER M8		10X
HW4	RING M8		10X
HW5	NUT M8		4X
HW6	L-KEY		1X

PREPARATION

- * Before beginning assembly of product, make sure all parts are present. Compare parts with part contents list hardware contents list.
- * If any part is missing or damaged, do not attempt to assemble the product.
- * Estimated Assembly Time: 10 minutes.
- * Tools Required for Assembly (included): Allen Key
- * If you are having difficulty, our friendly Customer Care team is always here to help.

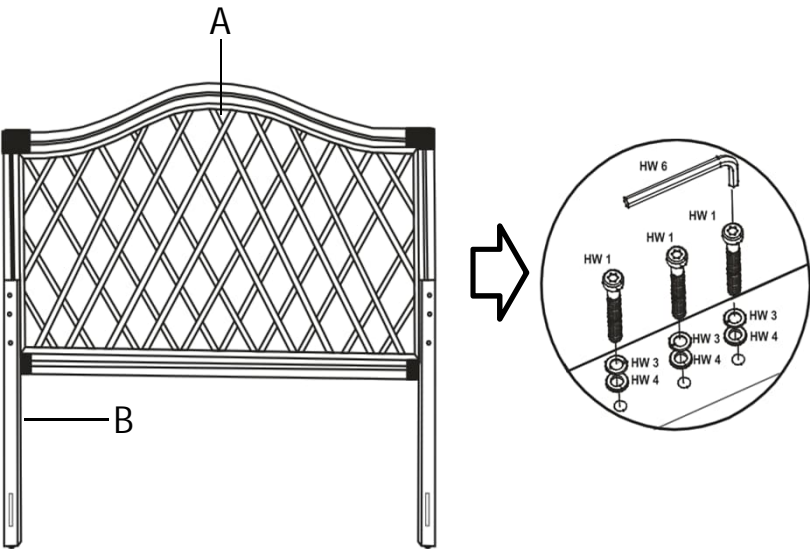
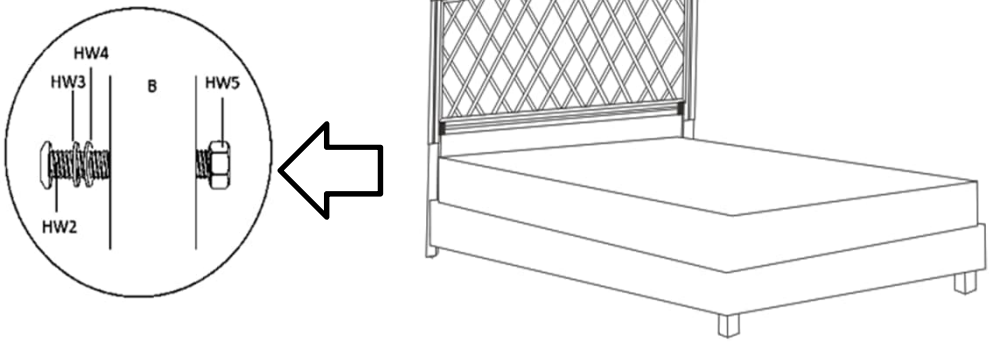
	
<p>STEP 1 ATTACH LEGS TO HEADBOARD PLACE THE HEADBOARD (A) FACE DOWN ON A SOFT SURFACE. ALIGN THE TWO WOODEN LEGS (B) WITH THE MOUNTING POINTS ON THE BACK OF THE HEADBOARD. USE : 6 X HW1 (8X50 MM BOLTS) 6 X HW3 (WASHERS) 6 X HW4 (RINGS) INSERT BOLTS THROUGH THE LEGS INTO THE HEADBOARD, ADDING A WASHER AND RING TO EACH. TIGHTEN ALL BOLTS USING THE ALLEN KEY (HW6).</p>	<p>STEP 2: ATTACH HEADBOARD TO MATTRESS BASE POSITION THE ASSEMBLED HEADBOARD UPRIGHT BEHIND YOUR MATTRESS BASE. USE : 4 X HW2 (8X60 MM BOLTS) 4 X HW5 (NUTS) 4 X HW3 (WASHERS) 4 X HW4 (RINGS) SECURE THE HEADBOARD TO THE BASE USING BOLTS, WASHERS, RINGS AND NUTS. TIGHTEN ALL CONNECTIONS FIRMLY.</p>