

INSTALLATION INSTRUCTION

WALLMOUNT SINK

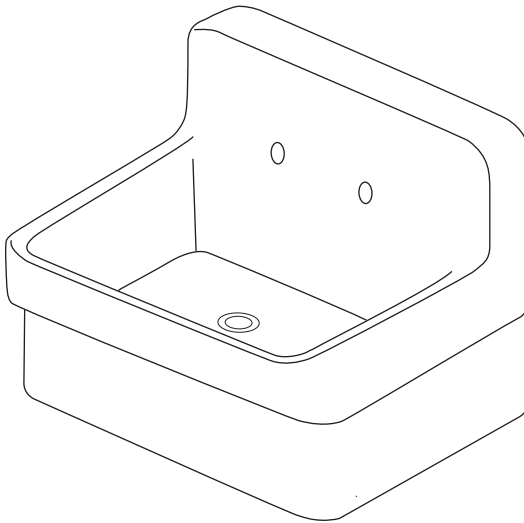

GETPRO CUSTOMER SERVICE:

Hotline: 626 679 3588

E-mail: service@getprohome.com



Prior to Installation:

- Observe and comply with all building and plumbing codes.
- As our basins are handcrafted and dimensions are approximate, we recommend using the actual basin for the cutout.
- Use sink clips and 100% Silicone (non-water based) for installations.
- Ensure adequate space behind the basin for faucet and backsplash, including the full range of motion for faucet handles and spouts.
- Make sure a watertight seal exists on all drain connections.
- Do not place basin directly on floor. After unpacking, place basin on protective material such as packing materials.
- Remember to always use non-abrasive cleaners on GETPRO sinks.

General Recommendations:

please read installation instructions thoroughly before installing the wall mount utility sink.

be sure to use proper tools and always wear proper personal safety accessories for your protection.

Tools and Materials



Tape Measure



Drill



Plumbers Putty



Putty Knife

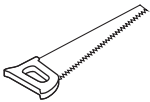

Hack Saw

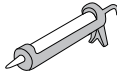

Silicone Adhesive



Screwdriver

Plus:

- (1) Pipe Wrench
- (2) Channel Lock
- (3) Tubing Cutter
- (4) Basin Wrench
- (5) Saber saw
- (6) Adjustable Wrench

NOTE

Additional tools might also be used to complete the installation.

Parts List:

- (1) Wall Mount Utility Sink x 1
- (2) Mounting Bracket x 2
- (3) Basket Strainer x 1

Sold Separately

- Wall-mount Faucet x 1
- Sewage Trap x 1

Prior to Installation



Read the following instructions thoroughly before installation of the sink:

- Observe all local plumbing and building codes.
- Shut off hot and cold water supplies. Inspect drain and supply tubing. Replace if necessary.
- Unpack new sink and inspect it for damage. Afterward, return the sink to its protective carton until the installation begins.
- Two persons are required to place and install the sink.
- The cabinet and frame shown in the illustrations are generic and intended as suggestions only. All illustrations in the following instructions assume installation with a standard countertop. Other countertop sizes may also be used.
- Use proper securing hardware and techniques to ensure the support frame will bear a minimum of 300 lbs (136kg).

Installation Procedures

Wall Mount Installation

Step I. Install Mounting Brackets

- Make sure the water supply is 8" apart for a two-hole faucet installation.
- The mounting brackets should be 11.4" to 11.8" apart. Mark the intended locations with a pencil. Check for levelness.
- Hold the brackets level and mark the locations for the screw holes on the wall. Install the mounting brackets to the wall and check again for levelness before fully tightening all screws into position.

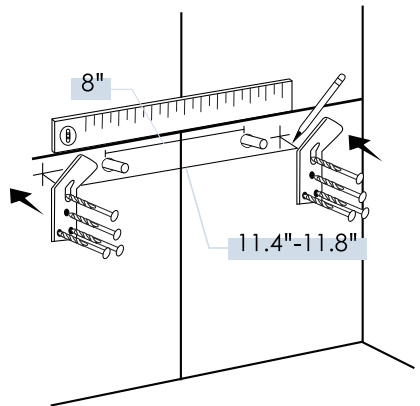

Step II. Install Sink

- Carefully lower the sink onto the bracket using the slot on the back of the item and check levelness. Make adjustments if necessary.



CAUTION Risk of personal injury or product damage. Get help lifting the sink.

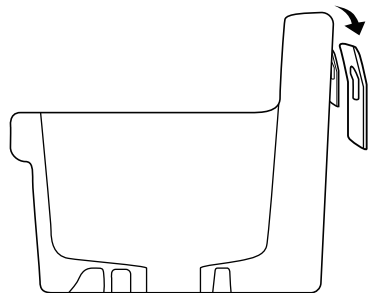

- Install faucet and drain assembly according to the manufacturer's instructions.

Reminder Do not overtighten fittings as it might damage the chinaware.

c. Run water to test for leakage.

Top Mount Installation

- Before proceeding, determine your cabinet design:

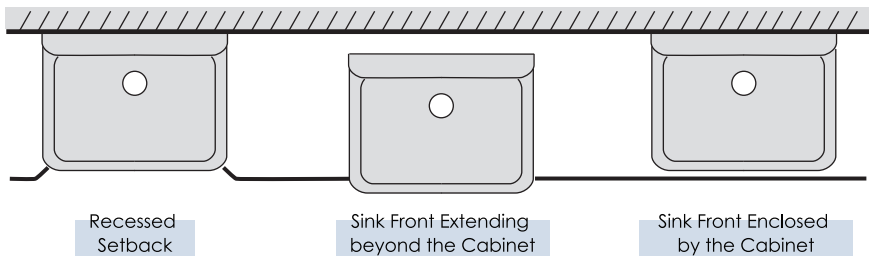

Step I. Construct Cabinet and Support Frame

a. Measure the actual size of sink below the rim flange.

NOTE The cabinet opening should equal the sink dimensions to ensure a minimum gap between the sink and the cabinet. If the sink is not available at the time of cabinet construction, make allowances to add wood filler strips to the opening after the cabinet is constructed and before the sink is installed.

b. Carefully measure and sketch the cut-out area according to the measurements taken from the actual sink. Cut the countertop and cabinet along the traced lines.

c. Construct a wood support frame inside the cabinet opening using 2x4 lumber and a 1/2" plywood, as shown in the illustration. Locate and cut the drain outlet clearance hole on the plywood.

NOTE Make sure the distance between the top of plywood and the top of countertop is identical to the distance between the bottom of the sink and the bottom of the sink rim.

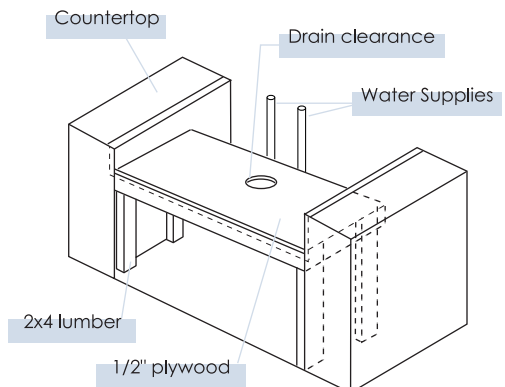

Installation Guide

Step II. Install Sink

a. Temporarily place the sink onto the cabinet opening. Check for alignment and clearance, then trace around the outside edge of the sink as a guide for application of sealant. Then remove the sink.

b. Apply a masking tape 1/8" outside the traced outline of the sink and apply a generous portion of silicone sealant inside the traced lines on the countertop.

c. Carefully lower the sink into place, properly position it using guidelines on the countertop, and press down firmly.

d. Apply additional sealant if necessary to provide a uniform bead from the sink rim to the masking tape. Remove any excess sealant and then the masking tape.

e. Install water supply and drainage system according to the manufacturer's instructions.

Reminder Do not overtighten fittings as it might damage the chinaware.

f. Run water to test for leakage.



CAUTION Risk of personal injury or product damage. Handle with care. Product can break, chip, cause injury or product damage if handled carelessly. Get help lifting the sink.

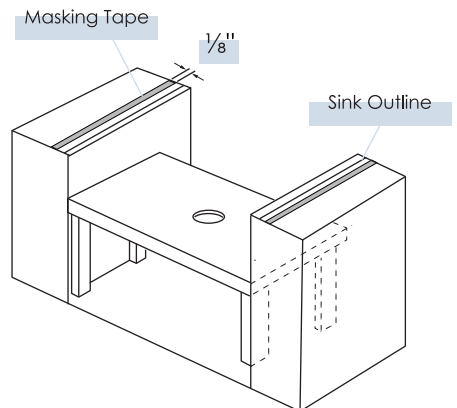
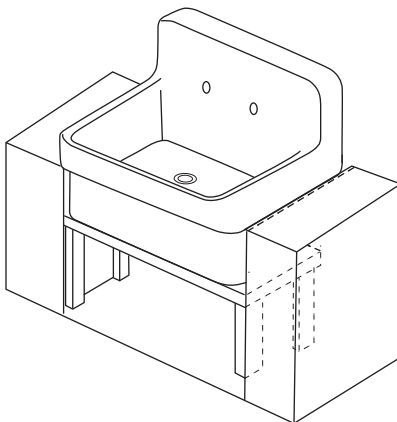

GETPRO Utility Sink are meticulously handcrafted with fine fireclay or ceramic and have undergone strict quality inspections. With proper care and cleaning measures, GETPRO sinks will keep in new condition and function well for an extended period of time.

General Cleaning



- It's recommended to clean GETPRO sinks on a regular basis to avoid the build-up of soap or mineral deposits.
- When cleaning, use a non-abrasive cleaner and a soft cloth to rinse the sink thoroughly and wipe it dry to eliminate water spots, as allowing water or cleaners to evaporate will have a negative effect on the appearance of the sink.

Do's



- ✓ Rinse laundry detergent thoroughly and make sure there's no residue.
- ✓ Wipe the sink dry using a soft cloth after each use.
- ✓ Scrape off any heavy grime with a plastic spatula.
- ✓ Use baking soda or mild detergent to clean off heavy stains.
- ✓ Test the cleaning solution on an inconspicuous area before applying it to the entire surface.
- ✓ Use a strainer to catch lint and small items like buttons to prevent clogging.



Strainer



Mild
Detergent



Plastic
Scraper

Don'ts



- ✗ Avoid storing open containers of household cleaners and chemicals containing chlorides such as bleach, acid, drain cleaners, or toilet bowl cleaner beneath the sink.
- ✗ Avoid using harsh, abrasive cleaners or chemicals as they will potentially scratch the surface.
- ✗ Avoid direct contact with sharp and metallic objects by using protective plastic bowls, rinse baskets, and sink grids with non-abrasive bases.
- ✗ Never use steel wool, cleaning pads, or any other form of abrasive cleaning materials to clean the sink as this may dull and damage the surface of the sink.
- ✗ Do not set hot pans or other hot items directly into the sink until they cool down.
- ✗ Do not leave any form of standing water in the sink, especially if the water contains anything that could stain the sink.

STRAINER INSTALLATION GUIDE

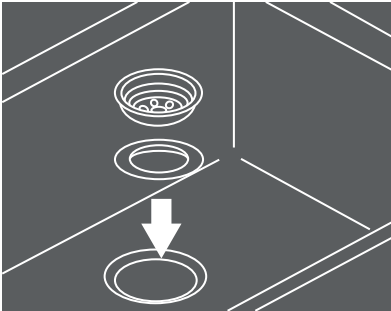

Step 1

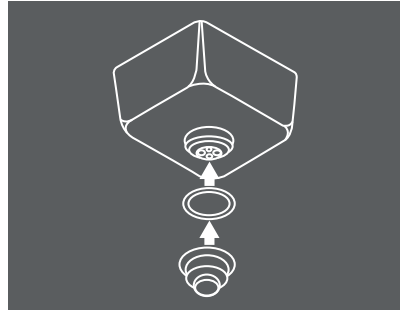

Step 2

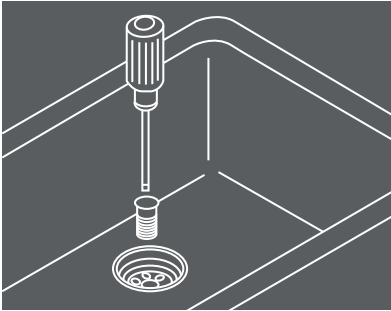

Step 3

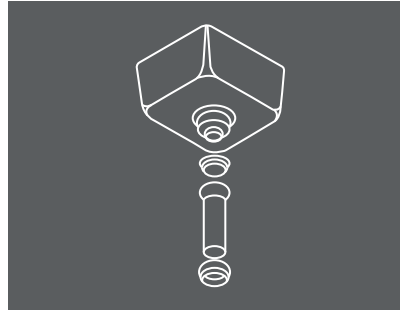

Step 4

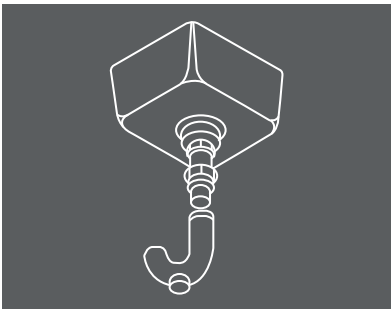

Step 5

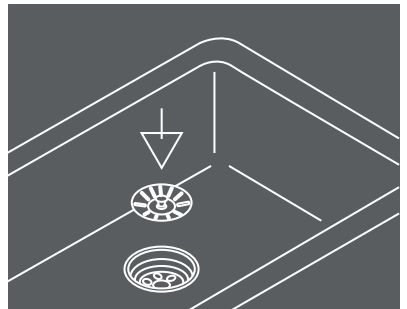

Step 6

LIMITED WARRANTY

- ◆ Offers a 3 years WARRANTY on Sink to be free of manufacturing defects under normal use.
- ◆ Will replace at no charge excluding transportation and labour costs, any Sink supplied by that is proven to have a manufacturing defect, to the original purchaser, provided it has been used solely in a residential application and installed correctly. An equivalent replacement will be issued to the original owner provided the defective sink was installed in accordance with the installation procedures, used and cleaned as recommended, and not damaged due to abuse, misuse, or negligence. Chips, scratches, and stains are not deemed to be manufacturing defects.
- ◆ Will not be held liable for chips, scratches, and stains that can occur under normal use over a period of time. Please refer to the cleaning instructions to maintain your sink.
- ◆ Shall not be held liable under this warranty where the sink has been used in a non-residential application, improperly installed, or damaged by an object being dropped on or impacting the sink or from improper handling.
- ◆ Shall not be liable for any inconvenience or expense for material or labor related to the removal or replacement of a defective sink or for any loss or damage to any person or property whatsoever resulting from the defective sink. All transportation costs to and from the point of purchase will be the responsibility of the purchaser.
- ◆ Any sink returned must be in the original packaging and include all the accompanying accessories, parts, and documentation. The manufacturer reserves the right to inspect and/or request digital pictures of any sink reported to be defective prior to replacement of the sink. Any manufacturing defect covered under this warranty must be reported to for warranty claim within 30 days of appearance.
- ◆ It is important that the professional fabricator installer and enduser carefully inspect the sink for damage immediately upon delivery.
- ◆ If any damage is not reported and documented on the delivery receipt with the shipping carrier upon delivery all insurance coverage ends and will not be able to file a claim or send a replacement sink.
- ◆ To submit a warranty claim it is the responsibility of the customer or installer to submit to a minimum of five(5) high resolution photographs clearly showing the manufacturing defect. Replacement cost excludes transportation and any labor costs for the removal or reinstallation.
- ◆ Under no circumstances shall be liable for any loss or damage arising from the purchase, a defect in, or use or inability to use this Sink, or for any special, indirect, incidental or consequential damages. Liability under this warranty is limited to the repair or replacement of the defective material to the location of purchase.