

Outdoor Patio Furniture Set 2 Seater Chair + Table

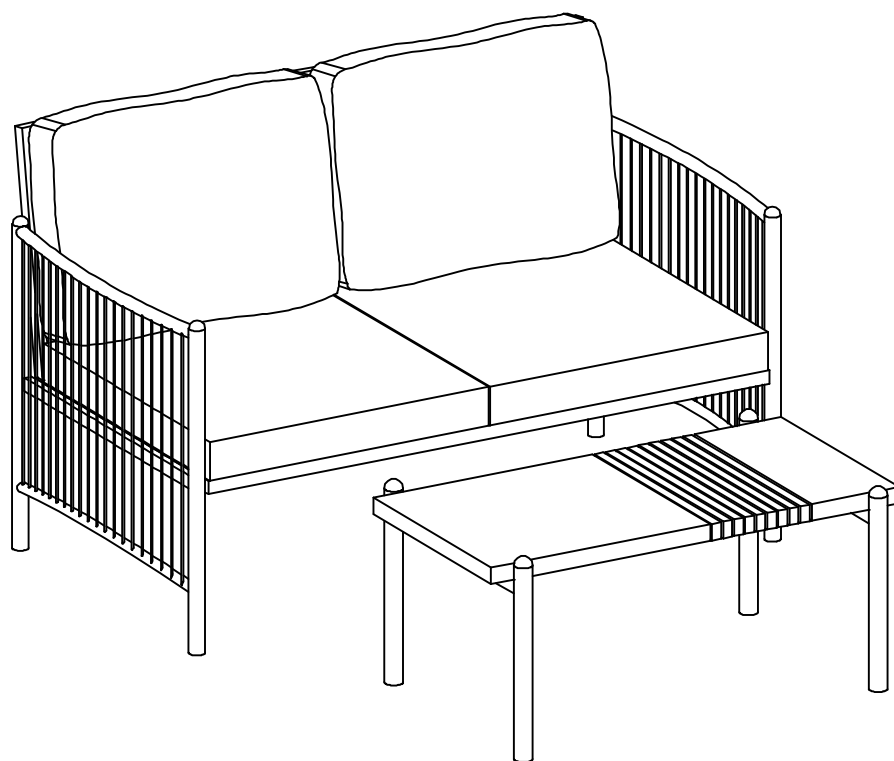

NOTICE

EN

Please keep these instructions for future reference.

Dear Customer

● Thank you for your purchase. When you receive the product, please make sure that all the parts are intact. If any parts are missing, please contact us promptly to request replacement parts.

● Then follow the entire installation instructions to install.

● Each part is crucial, so please be careful not to lose any. It is recommended to store parts with different lettered identifiers in separate boxes or bags to avoid confusion during installation.

A . The outer box is damaged

B . The product is damaged / bent / cracked while you open the box

C . The parts / accessories / assembly tools are missing

D . The instructions are not clear and can not be referred

E . The product has functional problems

F . Other aspects that you are not satisfied with

Veillez conserver ces instructions pour consultation ultérieure.

Cher client

● Merci pour votre achat. Lorsque vous recevez le produit, veuillez vérifier que toutes les pièces sont présentes et en bon état. En cas de pièces manquantes, veuillez nous contacter sans tarder afin d'obtenir les pièces de remplacement.

● Ensuite, suivez attentivement toutes les instructions d'installation pour procéder au montage.

● Chaque pièce est essentielle ; veuillez donc faire attention à ne pas en perdre aucune. Nous vous recommandons de ranger les pièces portant des identifiants alphabétiques différents dans des boîtes ou sacs séparés afin d'éviter toute confusion lors de l'installation.

A . L'emballage extérieur est endommagé.

B . Le produit est endommagé, tordu ou fissuré au moment de l'ouverture de l'emballage.

C . Des pièces, accessoires ou outils de montage sont manquants.

D . Les instructions ne sont pas claires et ne peuvent être utilisées comme référence.

E . Le produit présente des problèmes de fonctionnement.

F . D'autres aspects du produit ou du service peuvent vous insatisfaire.

Por favor, guarde estas instrucciones para futuras referencias.

Estimado cliente

- Gracias por su compra. Cuando reciba el producto, asegúrese de que todas las piezas estén intactas. Si falta alguna pieza, contáctenos inmediatamente para solicitar las piezas de repuesto.
 - A continuación, siga todas las instrucciones de instalación para proceder con el montaje.
 - Cada pieza es crucial, por lo tanto, tenga cuidado de no perder ninguna. Se recomienda guardar las piezas con identificadores de letras diferentes en cajas o bolsas separadas para evitar confusiones durante la instalación.
- A . El embalaje exterior está dañado.
 - B . El producto está dañado, doblado o agrietado al abrir la caja.
 - C . Faltan piezas, accesorios o herramientas de montaje.
 - D . Las instrucciones no son claras y no pueden consultarse adecuadamente.
 - E . El producto tiene problemas funcionales.
 - F . Otros aspectos con los que no está satisfecho.

Bitte bewahren Sie diese Anleitung für zukünftige Nachschlagesarbeiten auf. Sehr geehrter Kunde









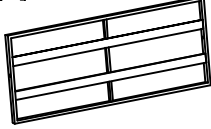
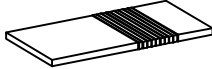
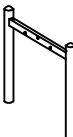
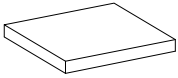

- Vielen Dank für Ihren Kauf. Prüfen Sie bei Erhalt des Produkts bitte, ob alle Teile vollständig und unbeschädigt sind. Sollten Teile fehlen, kontaktieren Sie uns bitte umgehend, um Ersatzteile anzufordern.
 - Befolgen Sie anschließend die gesamten Montageanweisungen, um die Installation durchzuführen.
 - Jedes Teil ist wichtig, daher achten Sie bitte darauf, keines zu verlieren. Es wird empfohlen, Teile mit unterschiedlichen Buchstabenkennzeichnungen in separaten Boxen oder Tüten aufzubewahren, um Verwechslungen während der Montage zu vermeiden.
- A . Die äußere Verpackung ist beschädigt.
- B . Das Produkt ist beschädigt, verbogen oder rissig, als Sie die Verpackung öffnen.
- C . Teile, Zubehör oder Montagewerkzeuge fehlen.
- D . Die Anweisungen sind unklar und nicht als Referenz geeignet.
- E . Das Produkt weist Funktionsprobleme auf.
- F . Weitere Aspekte, mit denen Sie unzufrieden sind.

Si prega di conservare queste istruzioni per consultazioni future.

Gentile cliente

- Grazie per l'acquisto. Quando riceve il prodotto, verifichi che tutti i componenti siano presenti e integri. In caso di componenti mancanti, la preghiamo di contattarci tempestivamente per richiedere i ricambi.
 - Quindi, seguire attentamente tutte le istruzioni di installazione per procedere al montaggio.
 - Ogni componente è essenziale; si prega quindi di fare attenzione a non perderne nessuno. Si consiglia di conservare i componenti con identificativi alfabetici diversi in contenitori o sacchetti separati per evitare confusione durante l'installazione.
- A .** L'imballaggio esterno è danneggiato.
- B .** Il prodotto è danneggiato, piegato o crepato all'apertura della confezione.
- C .** Alcuni componenti, accessori o utensili di assemblaggio sono mancanti.
- D .** Le istruzioni non sono chiare e non possono essere utilizzate come riferimento.
- E .** Il prodotto presenta problemi funzionali.
- F .** Altri aspetti con cui non è soddisfatto.

PART LIST

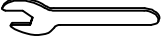
Ax1 	Bx1 	Ex1 	Fx1 
Kx1 	Lx2 	Mx2 	Nx2 
Px8  M6*30	Qx6  M6*40	Q1x4  M6*45	Tx24 
Ux6  M6	Vx1 	Wx1 	

WARNING

EN

Please do not tighten all the screws before the assembling is done.

DE

Bitte ziehen Sie alle Schrauben erst fest, wenn die Montage abgeschlossen ist.

FR

Veuillez ne pas serrer toutes les vis avant que l'assemblage ne soit terminé.

Ita

Si prega di non serrare tutte le viti prima che il montaggio sia completato.



ES

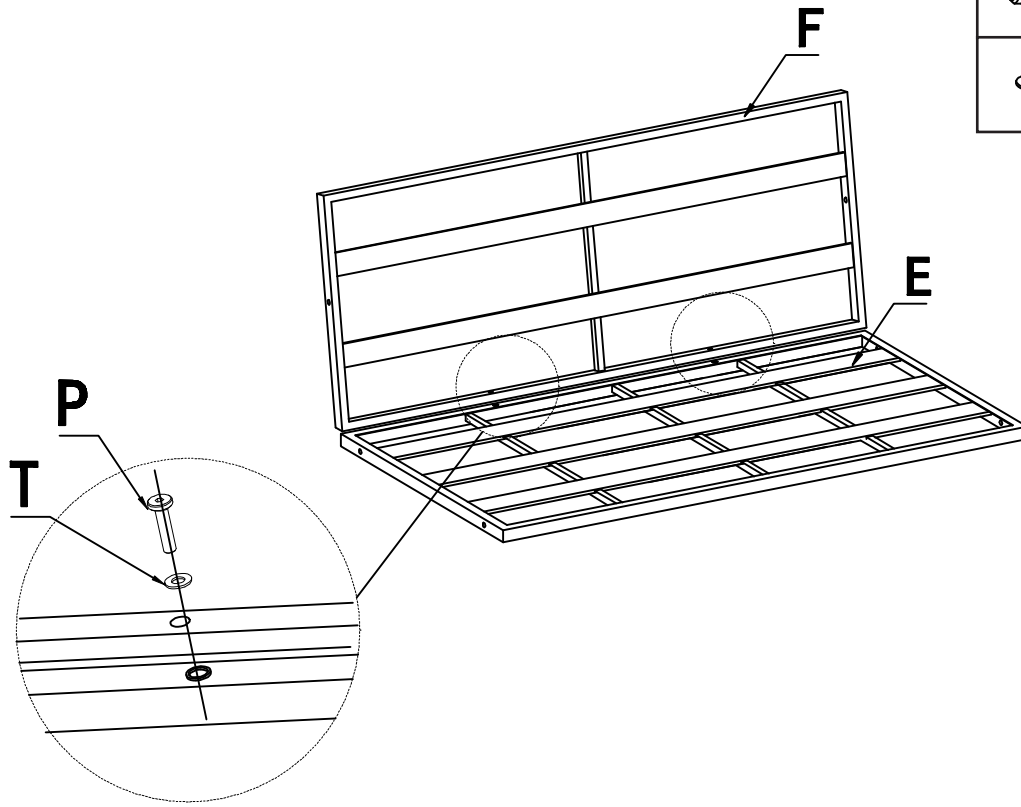

Por favor, no apriete todos los tornillos antes de que el ensamblaje esté terminado.

PART LIST

01





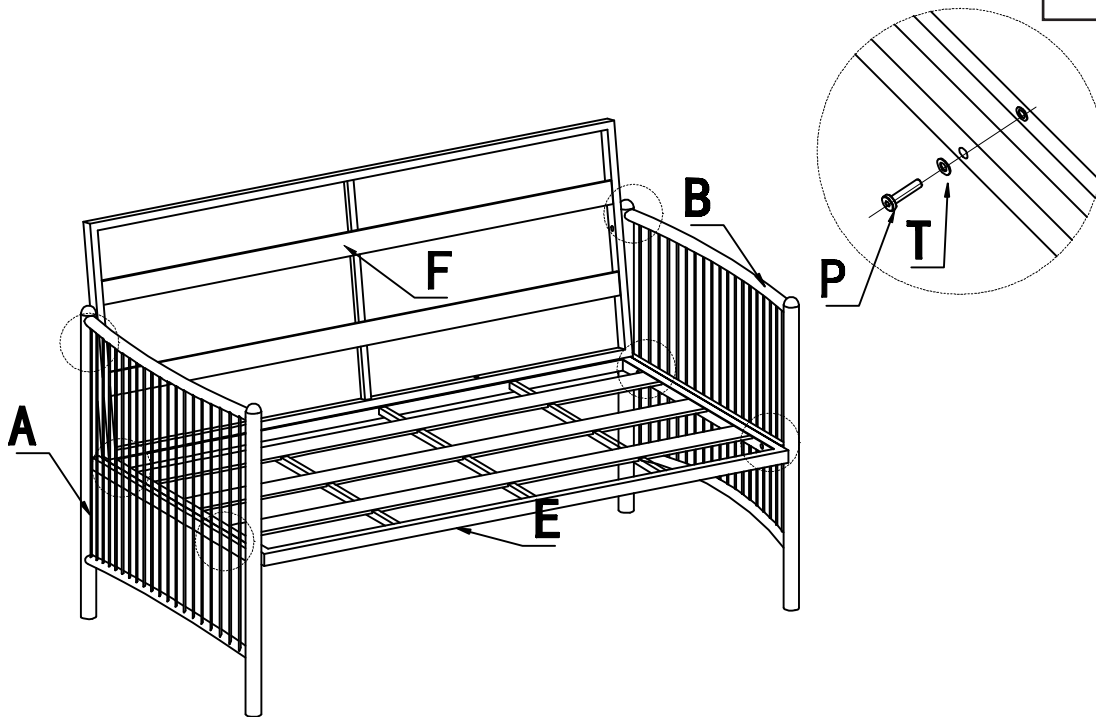

	P×2
	T×2

	50%
	✓
	✗

02



	P×6
	T×6

	100%
	✗
	✓



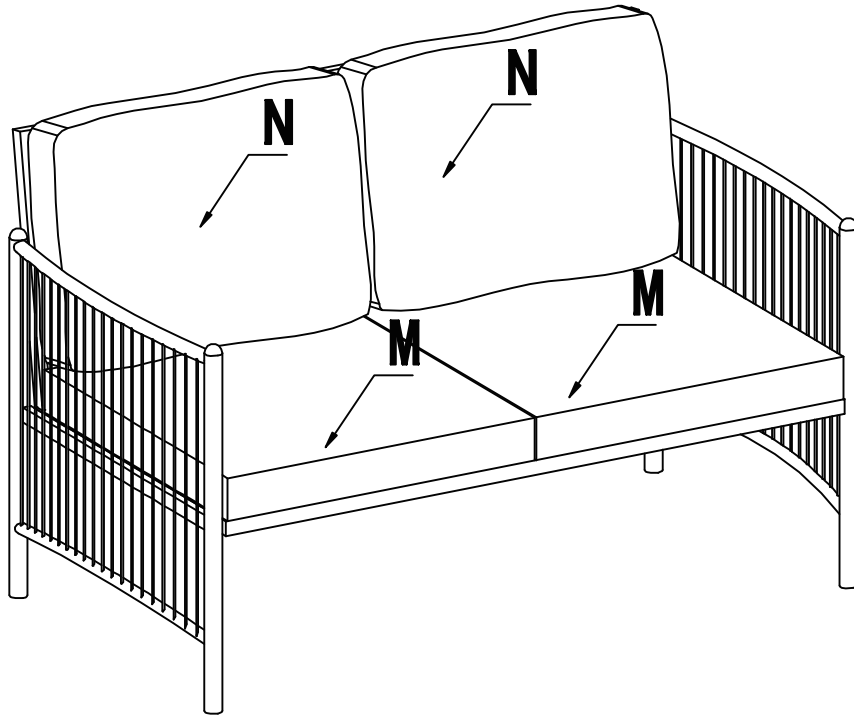

PART LIST

03

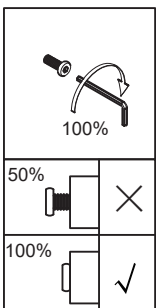
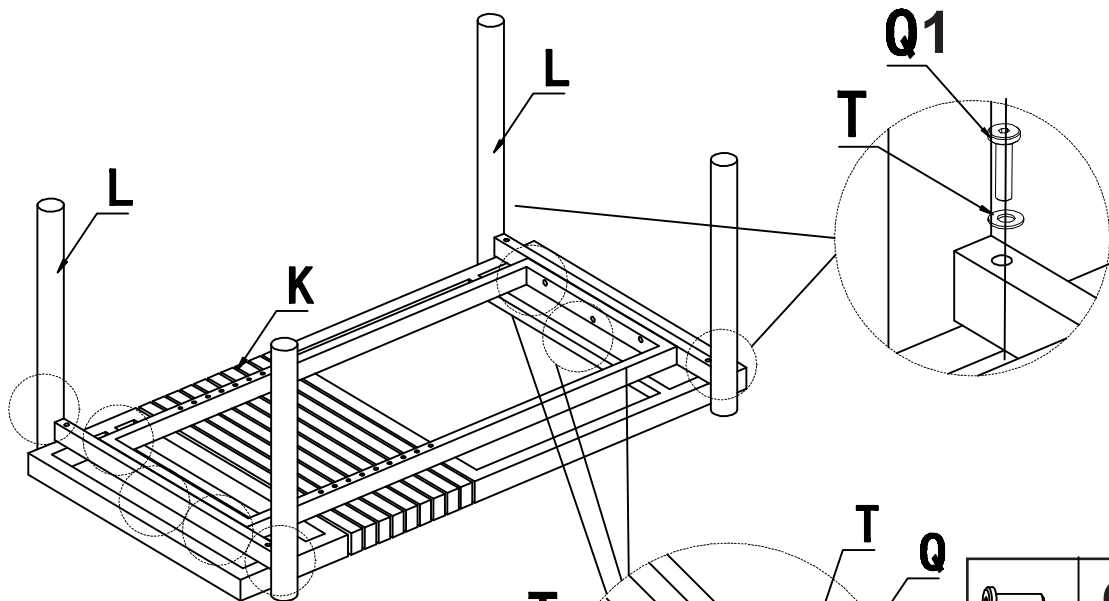

04



	Q×6
	Q1×4
	T×16
	U×6

08

05

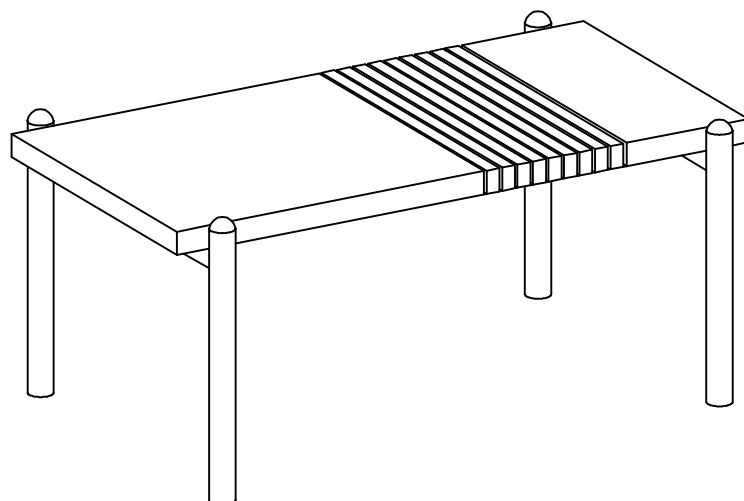

06

