

### Illustration of Installation

Caution: (Installed) in the parts table and hardware table means that it has been installed in the finished product, and is not in the hardware bag!!!

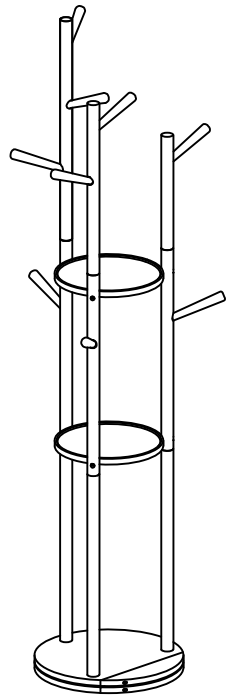

### List of Parts

No.	Name	Graph	Size	Amount
A	A Column*4		30*1560MM	1
B	B Column*4		30*1430MM	1
C	C Column*4		30*1300MM	1
D	Base 1		390*310*33MM	1
E	Base 2		315*80*15MM	2
F	Laminate		296*17MM	2
G	Handle		26*120MM	9

### List of Hardware

No.	Name	Graph	Size	Amount
1	Hexagon socket screw		M8*30MM	4
2	Hexagonal overmoulding wire		M7*50MM	11
3	Hexagon wrench		M5*57MM	1
4	Hexagon wrench		M4*57MM	1
5	Nonwoven fabric pad		φ20*3MM	5

This product has passed the wood inspection and paint inspection in full compliance with the national quality inspection standards. After passing the factory, it will be released from the factory and sold after confirming that the packaging is intact.

For better service, please feel free to give us your opinions on after-sales service.

Name:	Wood Furniture
Qualification:	Pass
Grade:	Class 1

Standard:  
GB/T 3324  
GB/ 18584

Required  
Workers



Inspector  
QC 02

Step 1: Install the base plate.

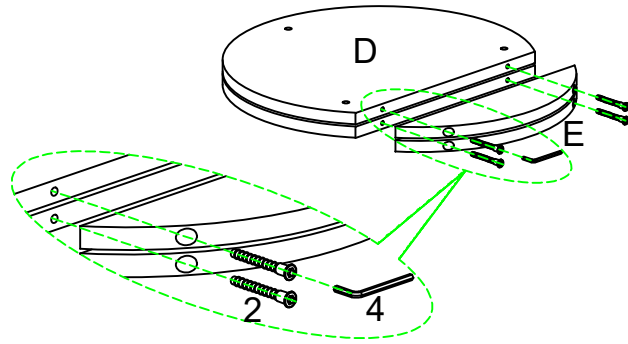

Caution: 1. After unpacking, check the correct number of accessories against the instructions.  
2. Tighten the base (D) and the base (E) with the hexagonal socket wire (2) using the L-shaped hexagonal spanner (4) as shown in the diagram.

Step 2: Install the base plate and A1, B1, C1.

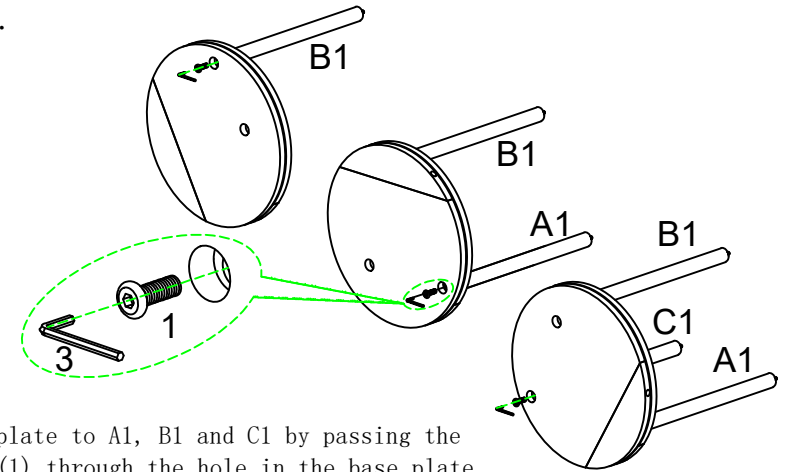

Secure the base plate to A1, B1 and C1 by passing the hexagonal screw (1) through the hole in the base plate.

(Note: it is not necessary to screw too tightly first, in order to facilitate the adjustment of the holes when installing the laminate later.)

Step 3: Install the base plate and A2, B2, C2.

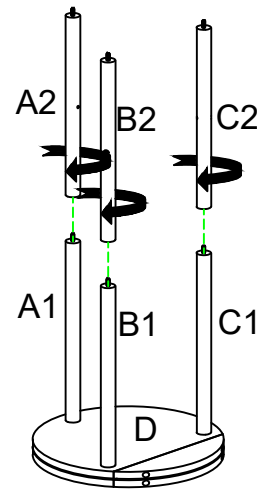

Align the poles A2/B2/C2 with A1/B1/C1 and turn them to tighten.

(Note: the 3 poles (A/B/C) with the same letter form one column, and the installation order is A1-A2-A3-A4, B1-B2-B3-B4, C1-C2-C3-C4. Please tighten every joint.)

Step 4: Install the first layer of laminates

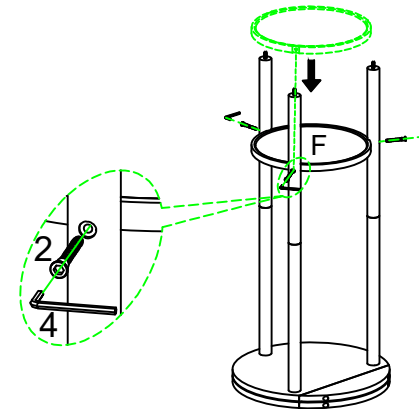

Follow the diagram: Fasten the laminate (F) with the hexagonal overmount wire (2) hexagonal spanner (4).

(Note: install with the large holes facing outwards and the small holes facing inwards)

Step 5: Tighten the bottom screw of the base plate

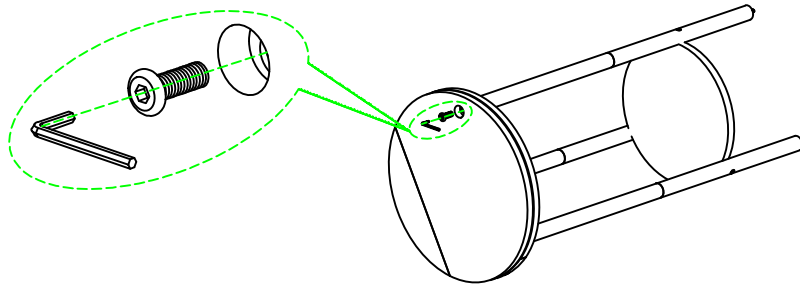

Tighten the bottom screw of the base plate after installing all the columns and laminate.

Step 6: Install column A3, B3, C3

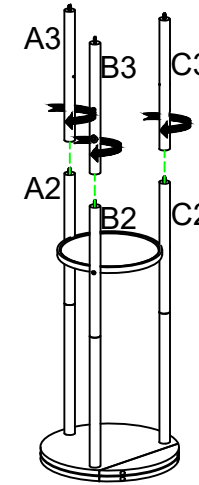

Screw the posts A3/B3/C3 against A2/B2/C2 by turning them.

Step 7: Install the second layer of laminates

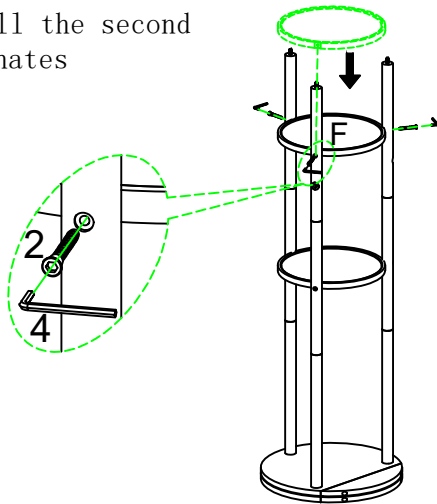

Fasten the laminate (F) with the hexagonal overmoulding wire (2) hexagonal spanner (4).

(Note: install with the large holes facing outwards and the small holes facing inwards)

Step 8: Install column A4, B4, C4

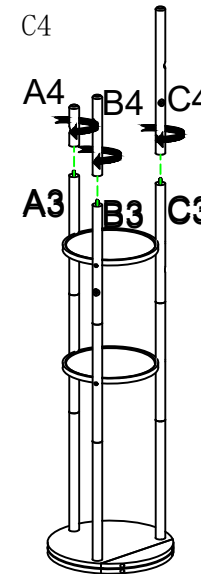

Screw the posts A4/B4/C4 against A3/B3/C3 by turning them.

Step 9: Install the handles

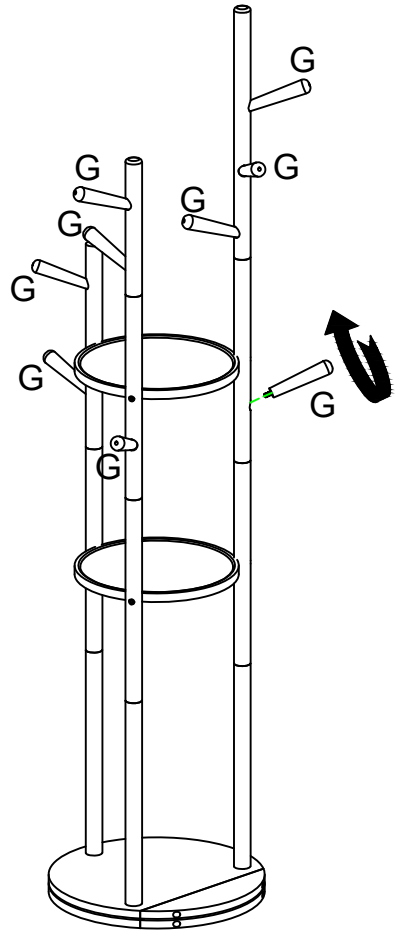

Fix all handles (G) onto the column as illustrated.

Step 10: Install the foot pad

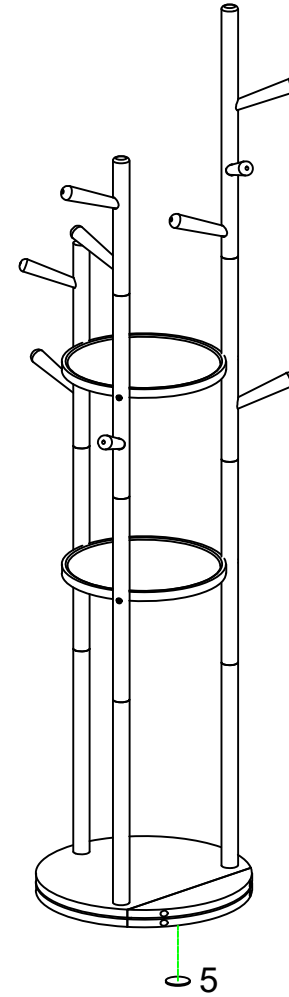

As illustrated, stick the foot pad (5) on the bottom surface of the bottom plate.