

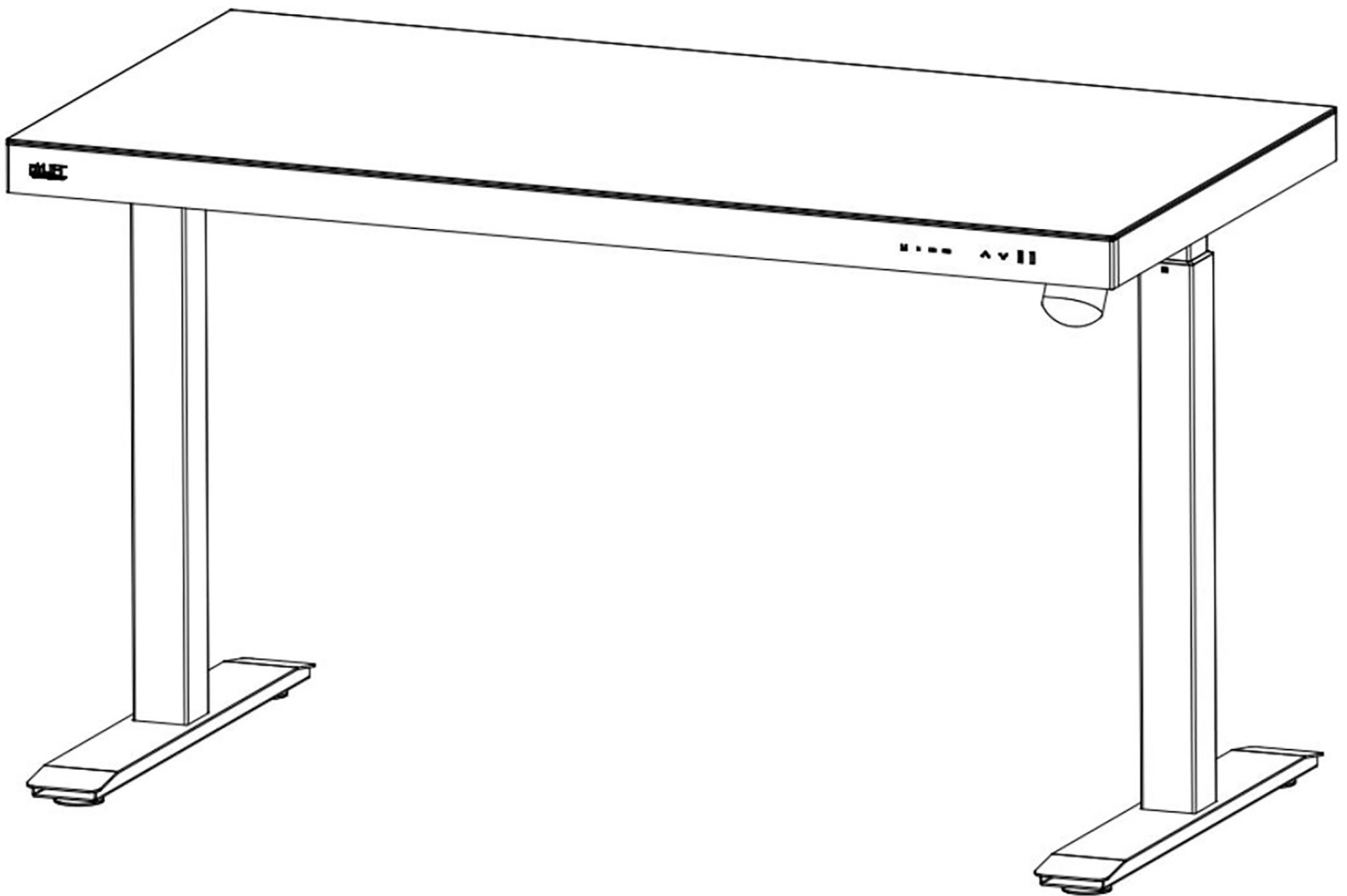

airLIFT[®] Glass & Wood Height Adjustable Standing Desk



Models: OFF65951B

Thank you for choosing Seville Classics! We hope that you enjoy your new sit-to-stand desk. Please read through this user guide for parts list, instructions, frequently asked questions and contact information.



User Manual
Keep for future reference



V02012022

Welcome and Congrats on your new Desk!

We at Seville Classics® are thrilled that you've chosen to go airLIFT®! Our desks are some of the easiest to use, most versatile and sophisticated electronic desks on the market. With this, you can stay active throughout the day without sacrificing productivity.

Choosing a height-adjustable desk is not just a convenient upgrade—it's a healthy one! Too much sedentary behavior can present a real health risk, even for people who are already healthy. Simply getting up throughout the day and moving is a great way to fight the consequences of too much sitting. airLIFT® is here to help.

Please read through this manual for more information regarding your airLIFT® Electric Height Adjustable Standing Desk.

Thank you for choosing Seville Classics®! We hope you will enjoy this desk for many years to come.

Post Setup Quick Start Instructions

Once your desk has been put together or when reset (initialization) is necessary:

- 1). Press & Hold the DOWN ARROW until the desk reaches the lowest position and/or stops moving.
- 2). Release your finger from the DOWN ARROW momentarily and then Press & Hold again until:
 - (a). Screen is flashing "RSt".
 - (b). Desk rebounds.
 - (c). You will hear a "DING" sound.
- 3). Release your finger and this completes the initialization/reset procedure.



Get help with assembly and report damaged or missing parts.

Email: Support@SevilleClassics.com

Telephone: 1 (800) 323-5565

Hours: 8:30 AM - 4:30 PM (PST)

Table of Contents

SAFETY INSTRUCTIONS.....	3
QUICK SETUP.....	4
PARTS LIST.....	5
TOOLS & HARDWARE LIST.....	5
ASSEMBLY INSTRUCTIONS.....	6
Unpack	6
Install Brackets	7
Install Legs	8
Connect Motor	9
Final Steps	10
INITIALIZATION & USE INSTRUCTIONS.....	11
TROUBLESHOOTING.....	12
WARRANTY INFORMATION.....	13
FCC INFORMATION.....	14
CUSTOMER SERVICE INFORMATION.....	15



Get help with assembly and report damaged or missing parts.

Email: Support@SevilleClassics.com

Telephone: 1 (800) 323-5565

Hours: 8:30 AM - 4:30 PM (PST)

Safety Instructions



FAILURE TO COMPLY WITH OR OBSERVE ALL ASSEMBLY, SAFETY AND OPERATING INSTRUCTIONS AND WARNINGS REGARDING THE USE OF THIS PRODUCT MAY RESULT IN SERIOUS BODILY INJURY



- Read and understand this manual before attempting to install or operate.
- Assure that everyone who uses this product is informed of the contents of this manual. This is the responsibility of the Purchaser.
- Not intended for use by young children or for those persons who require supervision.
- Do not open any of the components – legs, control box, or LED Control Panel. There is a risk of electric shock.
- Assemble desk on a flat and level surface.

Use & Liability

Safe use of this product is possible only when the operating instructions are read completely and the instructions contained are strictly observed. Persons who do not have the necessary experience or knowledge of this product must not use the product. Persons with reduced physical or mental abilities should not use this product, unless they are under supervision or they have been thoroughly instructed in the use of the apparatus by a person who is responsible for the safety of these persons. Children should be closely supervised to ensure that they do not play with this product.

Before You Begin

Layout all components and hardware. Visually examine and make sure components are free of damage. If there is visual damage to any component, it must not be installed.

Two people are needed to turn or move the desk and some of its components. When moving or turning the assembled desk, grab the legs, not the desk top.

Make sure to assemble on a soft and non-abrasive surface to avoid scratches.

Check all connections and cables. Make sure control box is connected to a power outlet.

If the control box makes unusual noises or emits an odor, switch power off immediately.

The desk MUST be INITIALIZED before first use.



Read the INITIALIZATION chapter prior to operation.



Get help with assembly and report damaged or missing parts.

Email: Support@SevilleClassics.com

Telephone: 1 (800) 323-5565

Hours: 8:30 AM - 4:30 PM (PST)

Quick Setup Diagram

Setup should take about 15 minutes to complete. All required tools are included. Keep the frame with tempered glass top in the box during assembly to protect it from scratches.

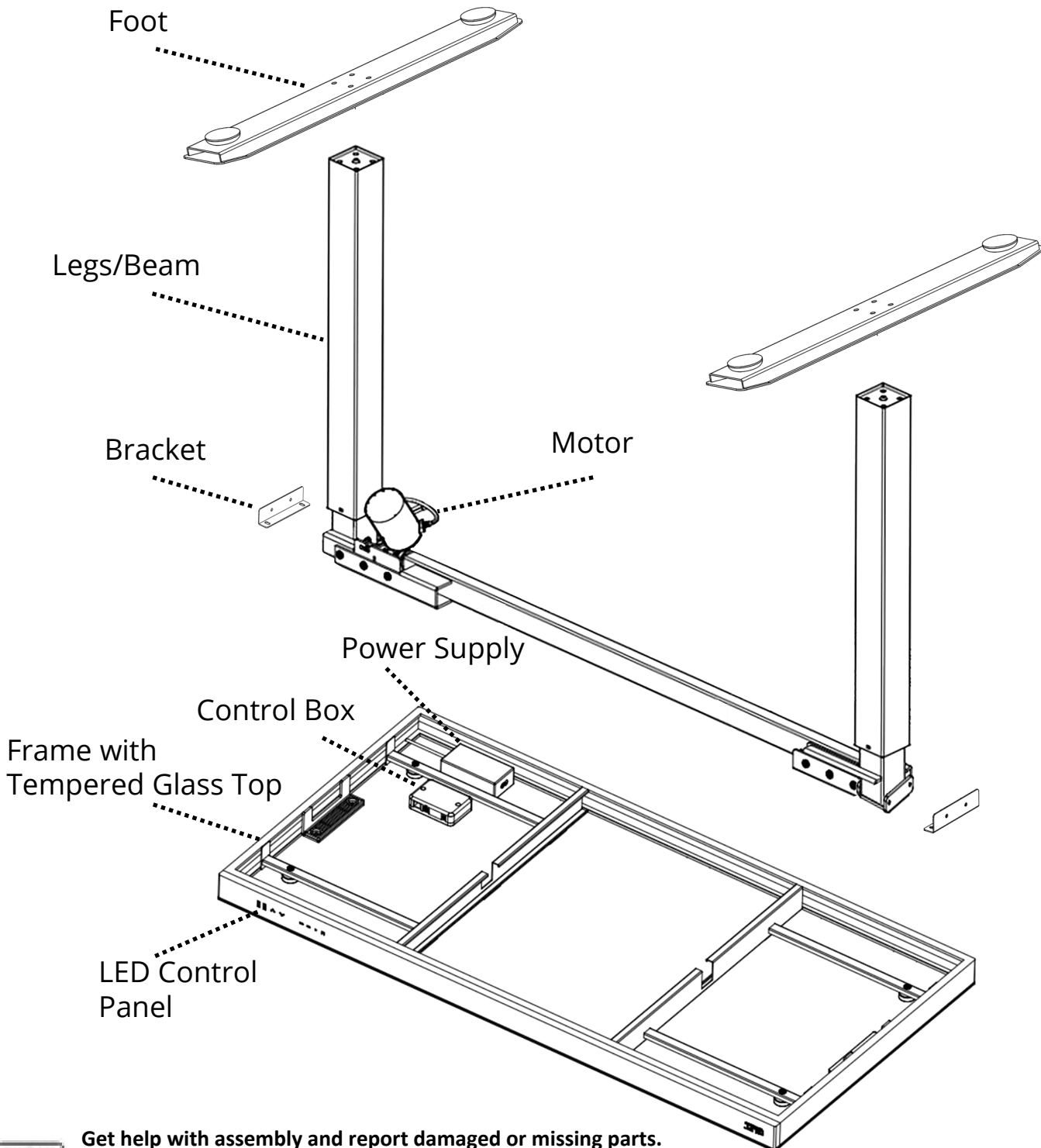



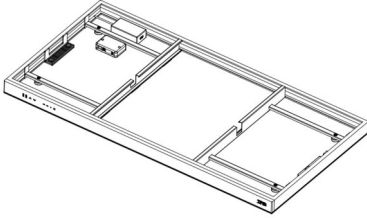
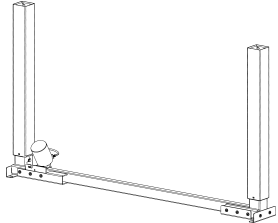
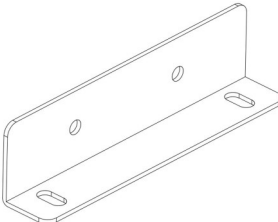
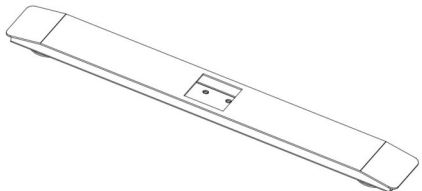

Get help with assembly and report damaged or missing parts.
Email: Support@SevilleClassics.com
Telephone: 1 (800) 323-5565
Hours: 8:30 AM - 4:30 PM (PST)

Parts List

<p>A. Frame with Tempered Glass Top (LED Control Panel, and Power Supply attached) (1)</p>	
<p>B. Legs/Beam (Motor attached) (1)</p>	
<p>C. Brackets (2)</p>	
<p>D. Feet (2)</p>	

Tools & Hardware List

<p>E. M6 x 12 Screws (8)</p>	
<p>F. M8 x 16 Screws (8)</p>	
<p>G. 4 mm Hex Key</p>	
<p>H. 5 mm Hex Key</p>	

**Please make sure you have all the parts on this list.
Leave the Top in the box during assembly**

If you're missing parts, contact us for replacements at (800) 323-5565 or send an email to Support@SevilleClassics.com

Assembly Instructions: Unpack

Remove the box lid and remove inner box containing parts. Leave the frame with tempered glass top in the **TOP** section of the box.

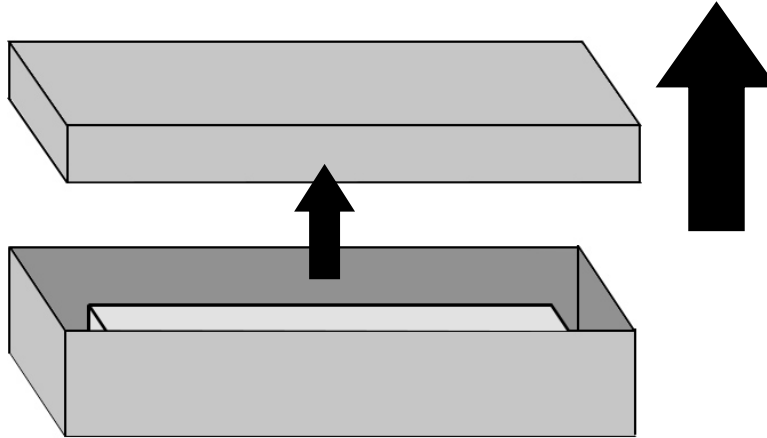

Layout all components and hardware. Examine each and make sure components are without damage.

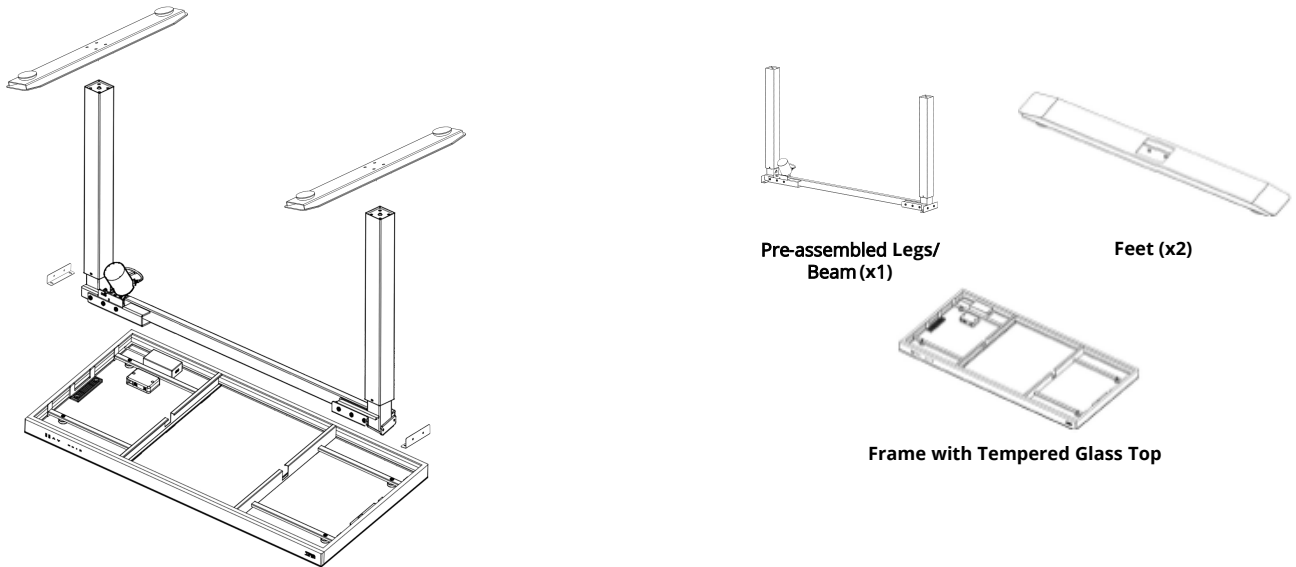

All Parts needed to assemble seen in above figure. Essentially just 4 simple steps of connecting 6 pieces in place.

Examine the location where you'll be using the desk. Make sure there is a grounded outlet or power strip nearby.

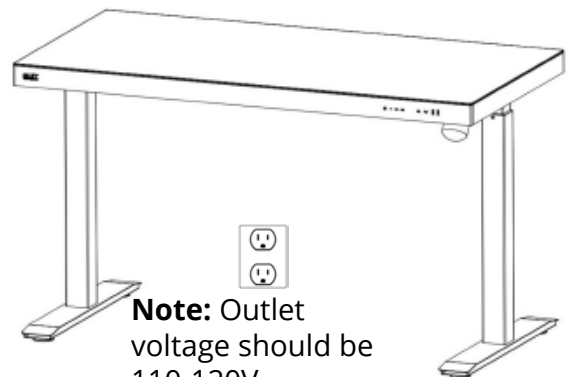

Get help with assembly and report damaged or missing parts.

Email: Support@SevilleClassics.com

Telephone: 1 (800) 323-5565

Hours: 8:30 AM - 4:30 PM (PST)

Assembly Instructions: Attach Support Brackets to Legs/Beam using the M6 x 12 screws.

STEP 1. Attach **BRACKETS (C)** to sides of **LEGS/BEAM (B)** with **M6 x 12 SCREWS (E)** using **4 mm HEX KEY (G)**.

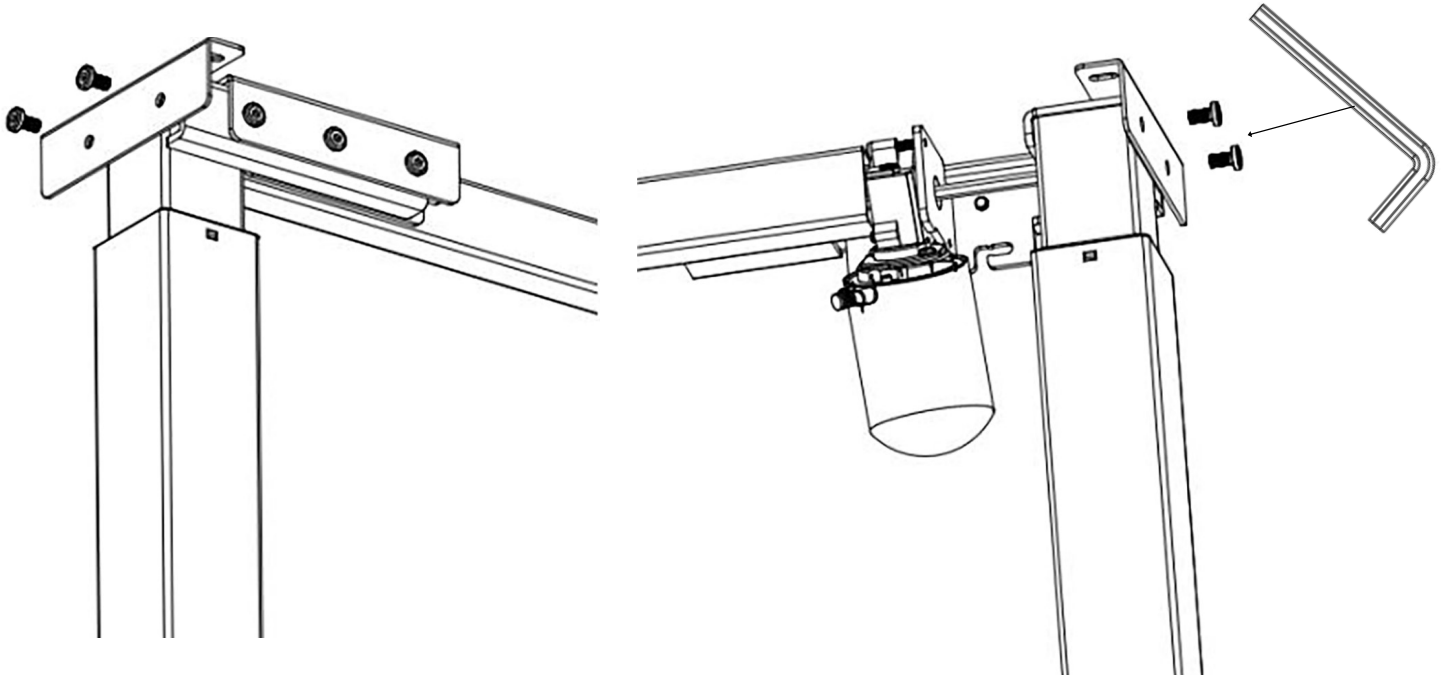

You should now have an assembled unit as pictured below.

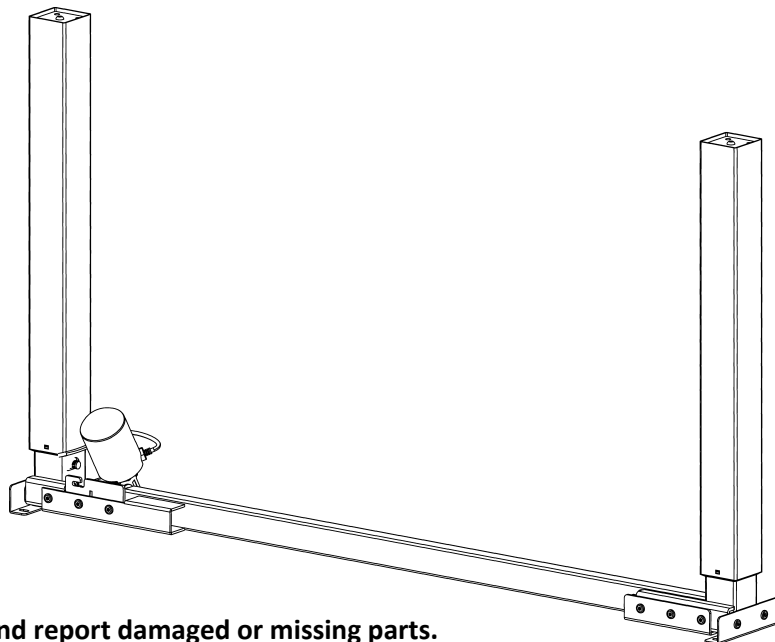

Get help with assembly and report damaged or missing parts.

Email: Support@SevilleClassics.com

Telephone: 1 (800) 323-5565

Hours: 8:30 AM - 4:30 PM (PST)

Assembly Instructions: Frame with Tempered Glass Top to Legs/Beam

STEP 2. Align **FRAME WITH TEMPERED GLASS TOP (A)** to the **FRONT**, the LED Control Panel should be facing you. Center the holes on **BRACKETS (C)** and attach with **M6 x 12 SCREWS (E)** using **4 mm HEX KEY (G)**. Make sure the motor is on the same side as the LED Control Panel.

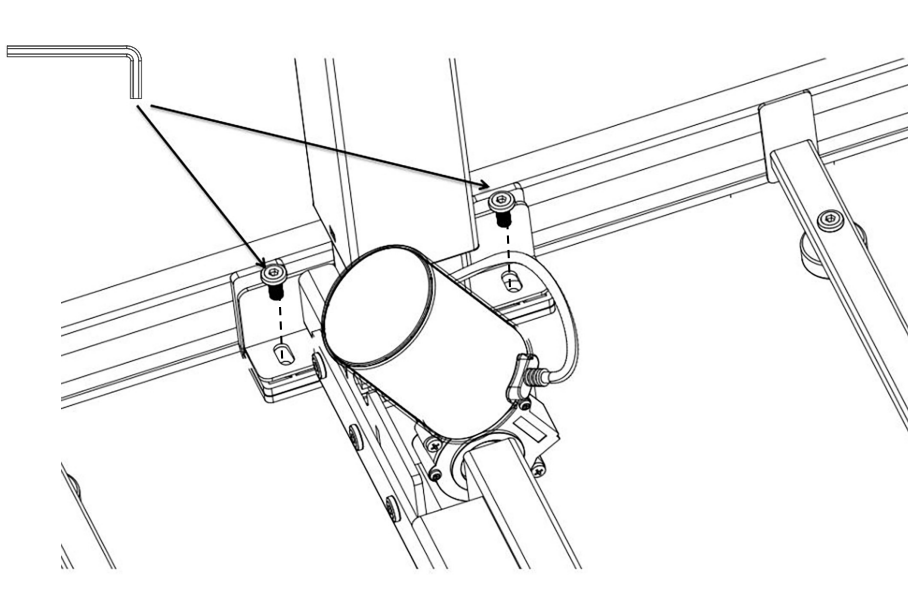
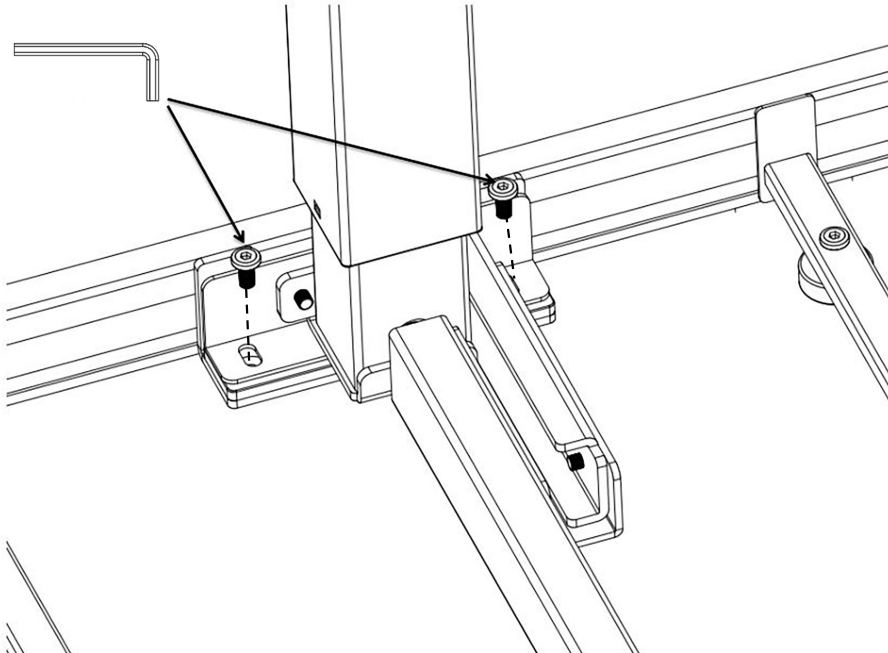

Get help with assembly and report damaged or missing parts.
Email: Support@SevilleClassics.com
Telephone: 1 (800) 323-5565
Hours: 8:30 AM - 4:30 PM (PST)

Assembly Instructions: Connect Motor Cable to Control Box

STEP 3. Plug in the **Motor Cable** from leg beam to **Control Box** as displayed in below figure.

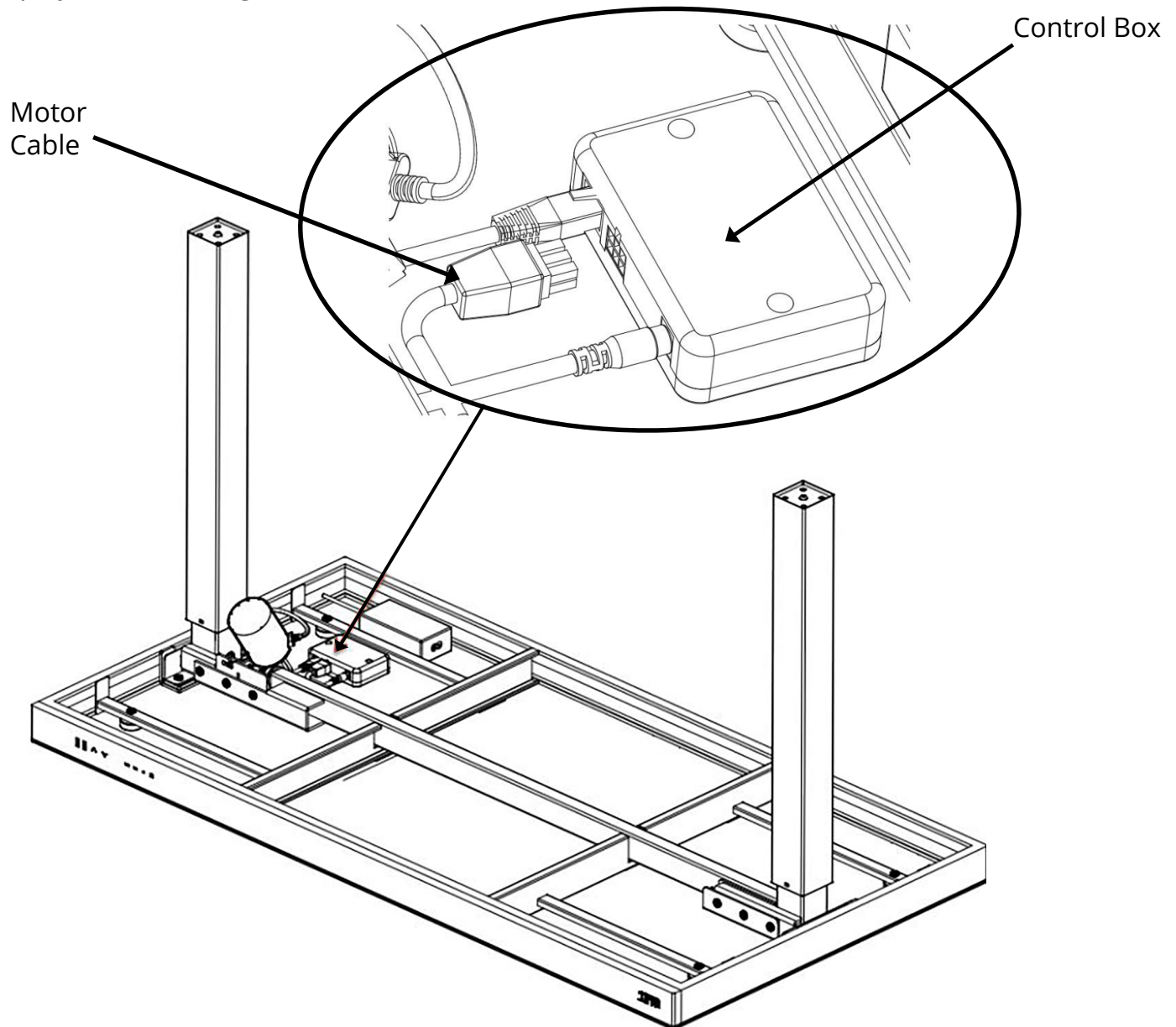

Get help with assembly and report damaged or missing parts.

Email: Support@SevilleClassics.com

Telephone: 1 (800) 323-5565

Hours: 8:30 AM - 4:30 PM (PST)

Assembly Instructions: Final Steps

STEP 4. Attach **FEET (D)** to the bottom of table legs with four **M8 x 16 SCREWS (F)** using **5 mm HEX KEY (H)**.

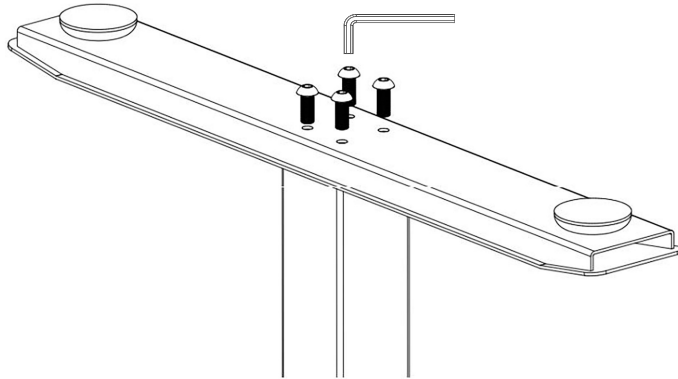

Tip! Take time to make sure all screws have been tightened.

STEP 5. With the assistance of another person, lift and tilt the table onto its feet.

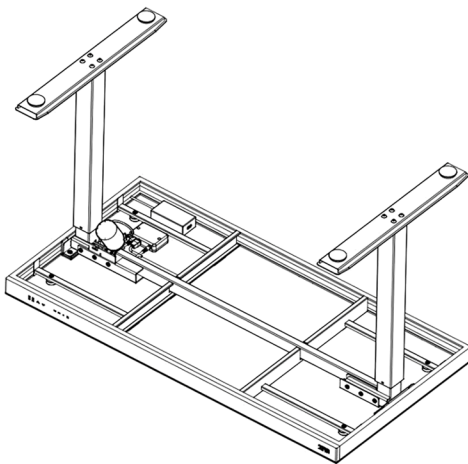

Lift with 2 people

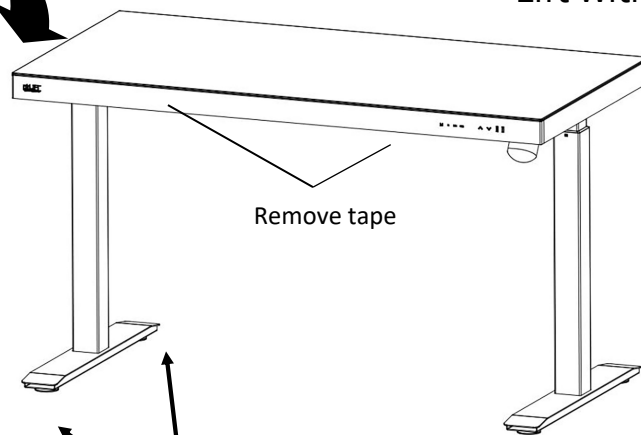

TIP: Adjust the leveling feet by rotating in and out as necessary to ensure the desk stands level and is not tilting.



Get help with assembly and report damaged or missing parts.

Email: Support@SevilleClassics.com

Telephone: 1 (800) 323-5565

Hours: 8:30 AM - 4:30 PM (PST)

Use Instructions

DESK MUST BE INITIALIZED BEFORE FIRST USE

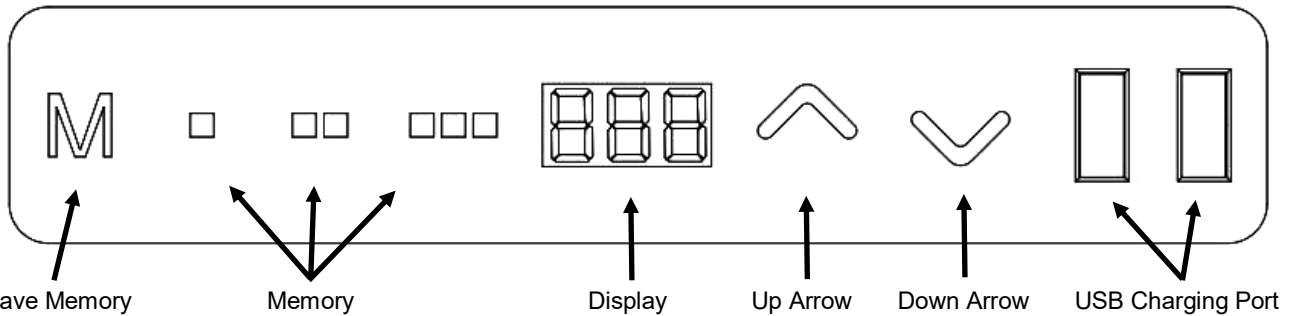

Initialize & Reset

Once your desk has been put together or when reset (initialization) is necessary:

- 1). Press & Hold the **Down Arrow** until the desk reaches the lowest position and/or stops moving.
- 2). Release your finger from the **Down Arrow** momentarily and then Press & Hold again until:
 - (a). Screen is flashing "RSt".
 - (b). Desk rebounds.
 - (c). You will hear a "DING" sound.
- 3). Release your finger and this completes the initialization/reset procedure.

Adjust Height

Press and hold the **Up Arrow** to lift.
Press and hold the **Down Arrow** to lower.

Save Height

To save the desired height, lightly tap the "**M**" button on the LED Control Panel, and an "**S-**" will appear. Now tap on any one of the 3 **Memory Buttons** to successfully save and store the desired height.

Note, If a flashing "**S-1**" appears on the LED Control Panel, this signifies that the "**M**" button was pressed for too long. Wait for the system to reset itself, should take 5 seconds, and then start the above process over.

Recall Height

Press the desired memory button. The desk will then adjust to the stored height.

Limited Height Setting

Control overall height limits of the desk to prevent the desk from going beyond a desired height level.

Press the **Up Arrow + Down Arrow** for 5 seconds until ding is heard.

Run to the limited height, press and hold **Up Arrow + Down Arrow** again for 5 seconds, when you hear the ding sound, limited height canceled.

Child Safety Feature

Press the **M button + Up Arrow** for 5 seconds to lock the LED Control Panel and prevent the desk from going up or down. LOC will display. Press the **M button + Down Arrow** for 5 seconds to unlock the LED Control Panel.



Get help with assembly and report damaged or missing parts.

Email: Support@SevilleClassics.com

Telephone: 1 (800) 323-5565

Hours: 8:30 AM - 4:30 PM (PST)

Troubleshooting

Problem	Action
Desk does not go up or down and the LED control panel does not illuminate when any button is pressed.	Check all connections. Make sure power cord is plugged into the control box and a power outlet. Press any button on the LED control panel and make sure it illuminates. Reset the desk.
Desk does not go up or down and the LED Control Panel shows "- - -"	The desk has an initialization fault and must be reset.
Legs do not go up evenly.	Unplug the power cord and re-plug after 10 seconds. Reset the desk.
Desk wobbles excessively.	It is normal that desk moves slightly at standing height when in use. Retighten all screws and bolts, and adjust leveling feet to make sure table stands level.
Desk legs are noisy.	It is normal that desk makes noise when the leg levels move past each other.

Error Codes

Code	Problem	Action
- - -	Initialization Fault	Reset the desk.
E01, E06, E07	Power Fault	Check to ensure all cables are connected.
E02, E08	Desktop Sloping	Make sure desk is adjusted evenly and reset the desk.
E04	LED Control Panel Fault	Unplug the LED Control Panel and plug it in once again.
E05	Anti-Collision Activated	Ensure that there is nothing obstructing the desk from moving.
E11, E13	Motor Cable Fault	Check the motor cable.
E12	LED Control Panel Fault	Contact customer service.
E14 - E16	Motor Fault	Check all cables and reset, if issue persists, contact customer service.
E17	Motor Cable Fault	Check motor cable and reset the desk.
E18	Overload	Remove some weight from the tempered glass desktop until error clears.
HOT	Motor Overheated	The desk motor is overheated. Stop using the desk for 20 minutes and let it to cool down.
LOC	Locked	To unlock, press "M" button and "Down Arrow" button at the same time.



Get help with assembly and report damaged or missing parts.

Email: Support@SevilleClassics.com

Telephone: 1 (800) 323-5565

Hours: 8:30 AM - 4:30 PM (PST)

Warranty Information

7-Year Non-Electronic Component Warranty

Seville Classics, Inc. warrants to the original retail purchaser that if this product proves to be defective in material or workmanship, we will replace the affected **non-electronic part(s)** for a period of **seven years** on Seville Classics airLIFT® Electric Height Adjustable Standing Desks from the date of original purchase.

2-Year Electronic Component Warranty

Seville Classics, Inc. warrants to the original retail purchaser that if this product proves to be defective in material or workmanship we will replace the affected **electronic part(s)** for a period of **two years** on Seville Classics airLIFT® Electric Height-Adjustable Standing Desks from the date of original purchase.

Except for the express warranty set forth above and except to the extent prohibited by applicable law, Seville Classics grants no other express or implied warranties with respect to the product, its fitness for any purpose, its quality, or its merchantability. The liability of Seville Classics under the warranty shall be limited to the amount paid by the customer for the product. Seville Classics shall not be liable for any loss of use of the product, or other incidental or consequential costs, expenses or damages incurred by the customer or other user.

This warranty covers only the airLIFT® Height Adjustable Standing Desk sold in the United States of America and Canada. Some states do not allow the exclusion or limitations of implied warranties or consequential damages, so the above limitations or exclusions may not apply to you. This warranty gives you specific legal rights, and you may also have other rights that vary from state to state.

During the applicable warranty period, Seville Classics, at its option, will either refund the original purchase price or replace the affected part(s) with comparable part(s) when the affected part(s) are returned, postage prepaid, to the address below:

Seville Classics Inc.
19401 South Harborage Way
Torrance, CA 90501 – 1322 U.S.A.

To obtain warranty coverage, you must:

Have an original copy of the purchase receipt or invoice from any authorized retailer.



For warranty questions please contact customer support.

Email: Support@SevilleClassics.com

Telephone: 1 (800) 323-5565

Hours: 8:30 AM - 4:30 PM (PST)

NOTE: This equipment has been tested and found to comply with the limits for Class B digital device, pursuant to part 15 of the FCC Rules. These limits are designed to provide reasonable protection against harmful interference in a residential installation. This equipment generates, uses and can radiate radio frequency energy and, if not installed and used in accordance with the instructions, may cause harmful interference to radio or television reception, which can be determined by turning the equipment off and on, the user is encouraged to try to correct the interference by one or more of the following measures:

- Reorient or relocate the receiving antenna.
- Increase the separation between the equipment and the receiver.
- Connect the equipment into an outlet on a circuit different from that to which the receiver is connected.
- Consult the dealer or an experienced Radio/TV technician for help



Get help with assembly and report damaged or missing parts.

Email: Support@SevilleClassics.com

Telephone: 1 (800) 323-5565

Hours: 8:30 AM - 4:30 PM (PST)

Customer Service Information

Telephone: (800) 323-5565

Fax: (310) 533-3899

Hours: 8:30 AM – 4:30 PM (PST)

Email: Support@SevilleClassics.com

Homepage: www.SevilleClassics.com