

# Assembly Instructions

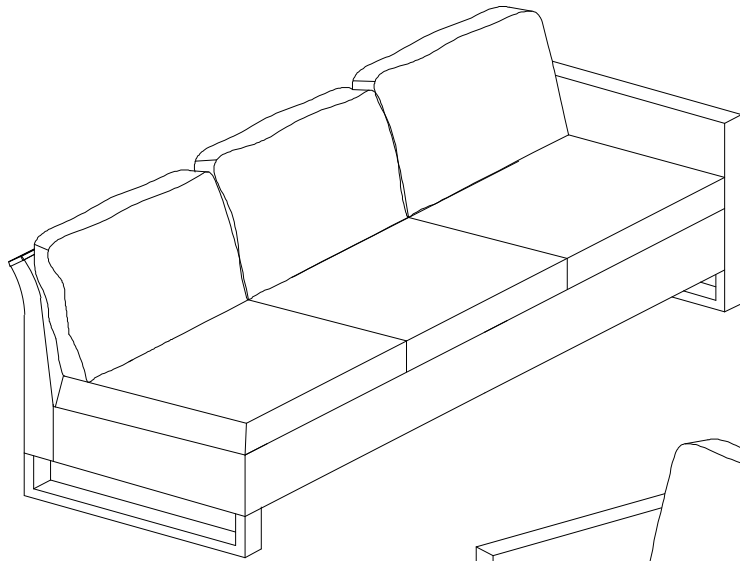

**Assembly  
Video**

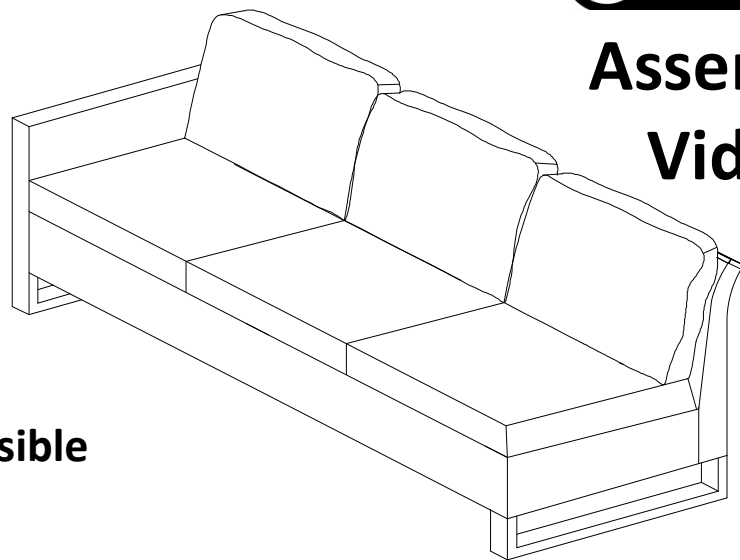

**This sofa arm is reversible**

For any missing hardware, damaged parts and other problems.  
WELCOME to email us at: [service@behousewell.com](mailto:service@behousewell.com)

Or call at 1-888-733-8169 Toll free  
Between 9AM and 5PM Eastern time, Monday through Friday

**\*Don't fully tighten all the bolts till the very end!**

## PRE-ASSEMBLY PREPARATION:

- Please read through the instructions before beginning assembly.
- Clear out the space for assembly and lay out all of the parts based on the Parts List, extra room will allow you to easily determine if all the pieces are present.
- Keep small parts and pieces away from children until fully assembled.

Part no.	Part	QTY	Image	Part no.	Part	QTY	Image
A	Arm (reversible)	1		I	Middle foot	2	
B	Right back panel	1		J	Back cushion	3	
C	Left back panel	1		K	Seat cushion	3	
D	Right front panel	1		L	Bolt (M6*20mm)	8	
E	Left front panel	1		M	Bolt (M6*35mm)	12	
F	Seat panel	3		N	Bolt (M6*40mm)	12	
G	foot	1		O	Washer M6	32	
H	Seat side panel	1		P	Ratchet wrench	1	

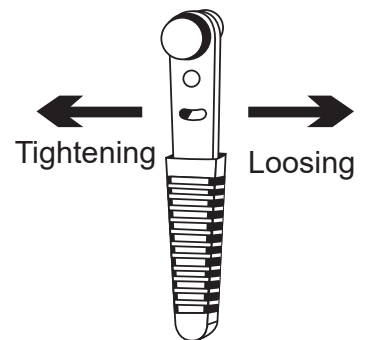
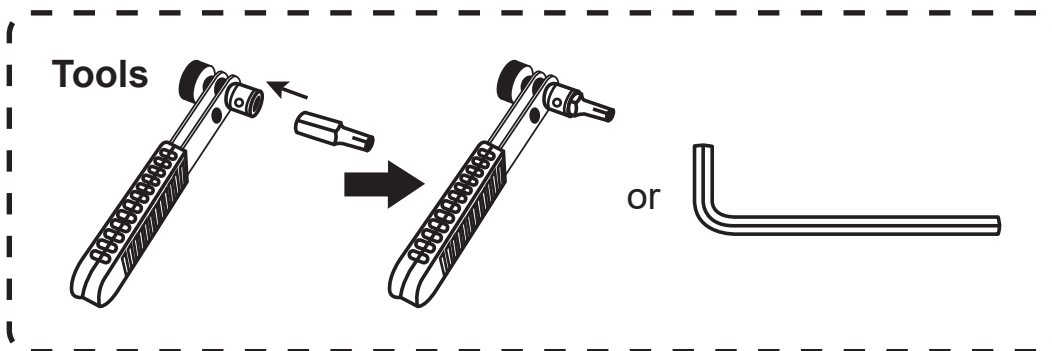

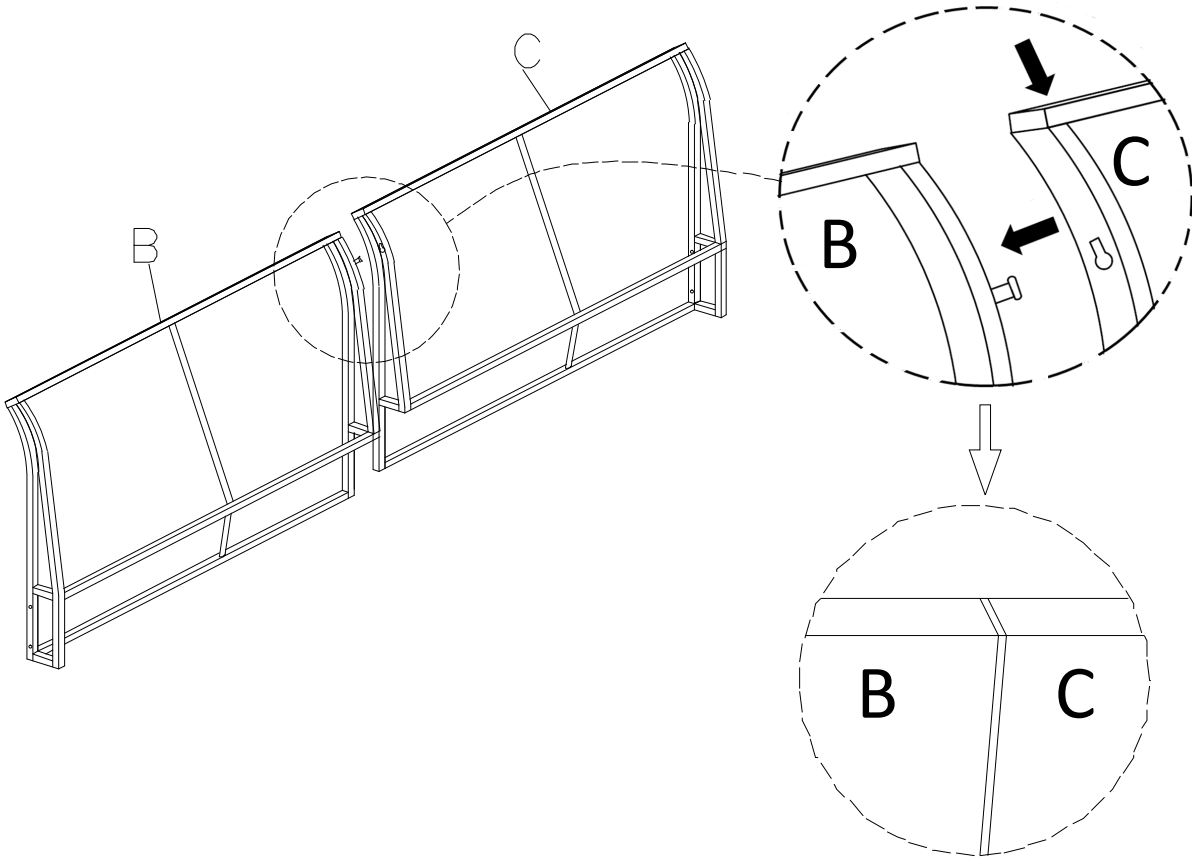

**Step 1:** Attach back B to back C, and press back C down to keep back B&C on the same level.



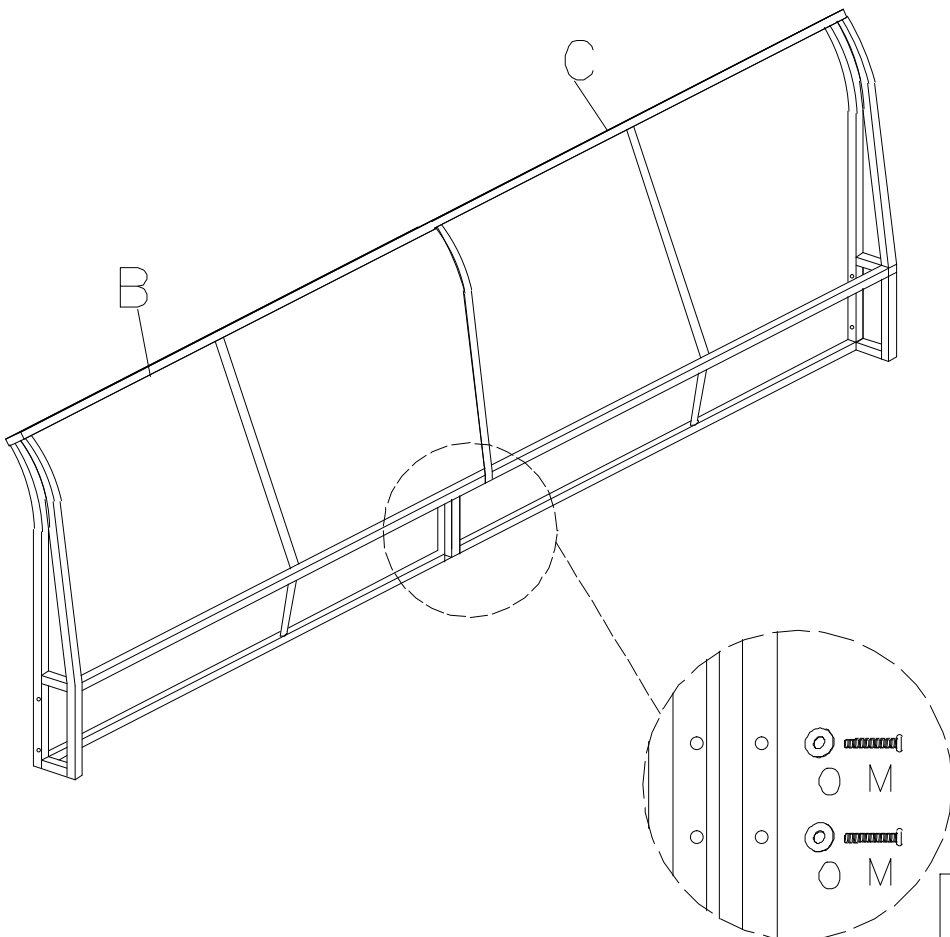

**Step 2:** Attach back B & C with 2pcs bolts M and 2pcs washers O, using Ratchet wrench P. Note: Don't fully tighten the bolts.

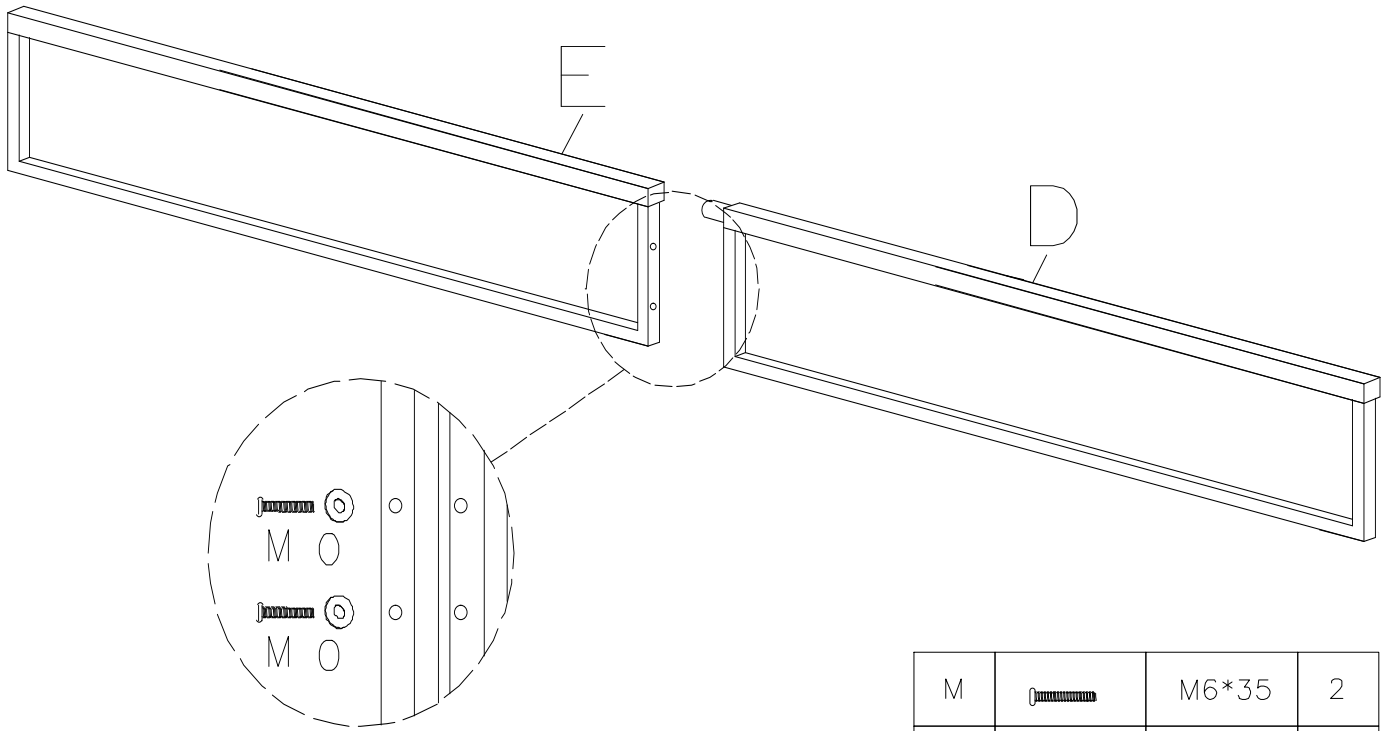

M		M6*35	2
O		M6	2

**Step 3:** Attach front panels E & D with 2pcs bolts M and 2pcs washers O, using Ratchet wrench P. Note: Don't fully tighten the bolts.





M		M6*35	2
O		M6	2

## Step 4: This arm is reversible.

If you need the sofa with left arm, please attach arm A on the left, to back C and front panel E with 4pcs bolts M and 4pcs washers O, using Ratchet wrench P.

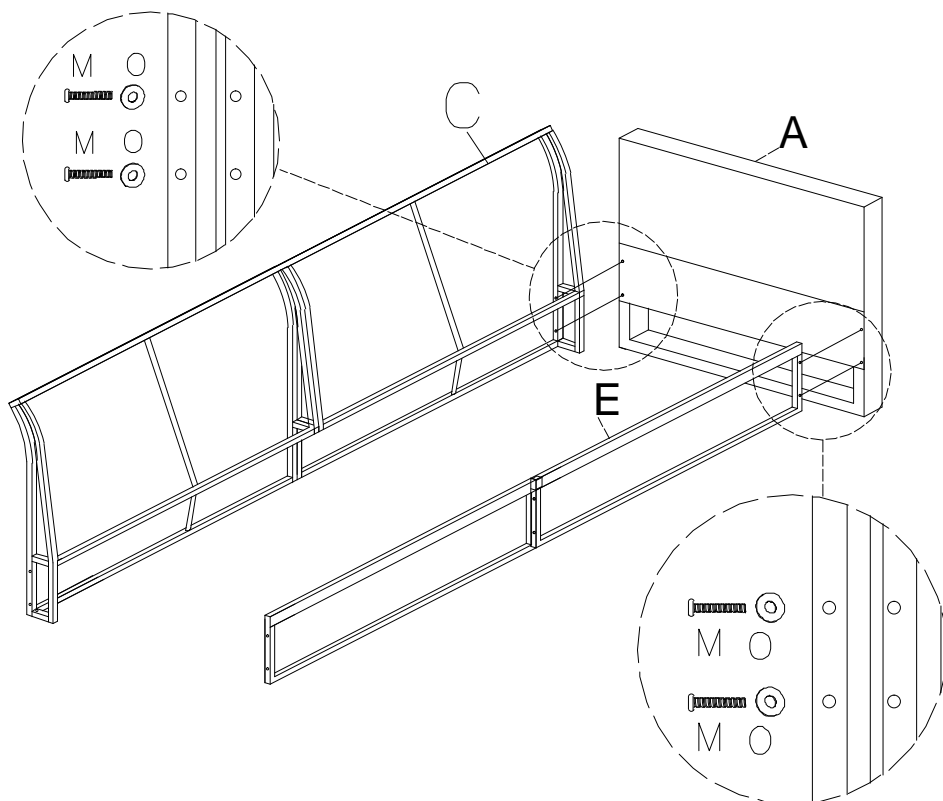
Note: Don't fully tighten the bolts.





M		M6*35	4
O		M6	4

If you need the sofa with right arm, please attach arm A on the right, to back B and front panel D with 4pcs bolts M and 4pcs washers O, using Ratchet wrench P.

Note: Don't fully tighten the bolts.

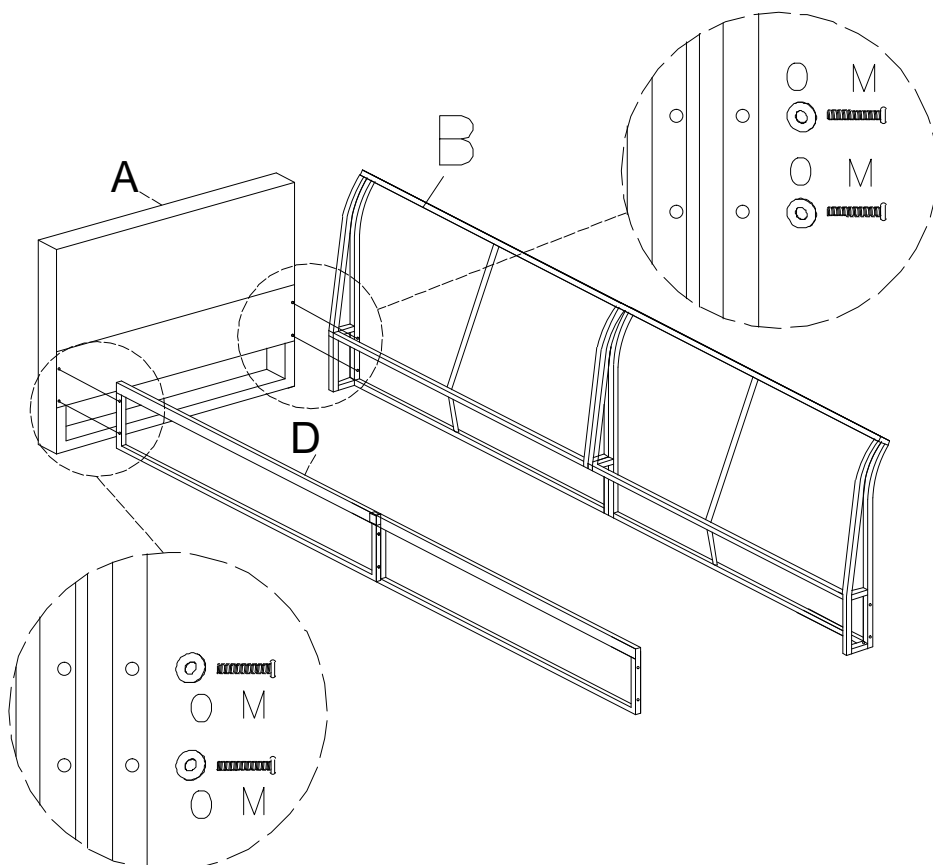

The **Next** assembly steps are same as the sofa with left arm.



M		M6*35	4
O		M6	4

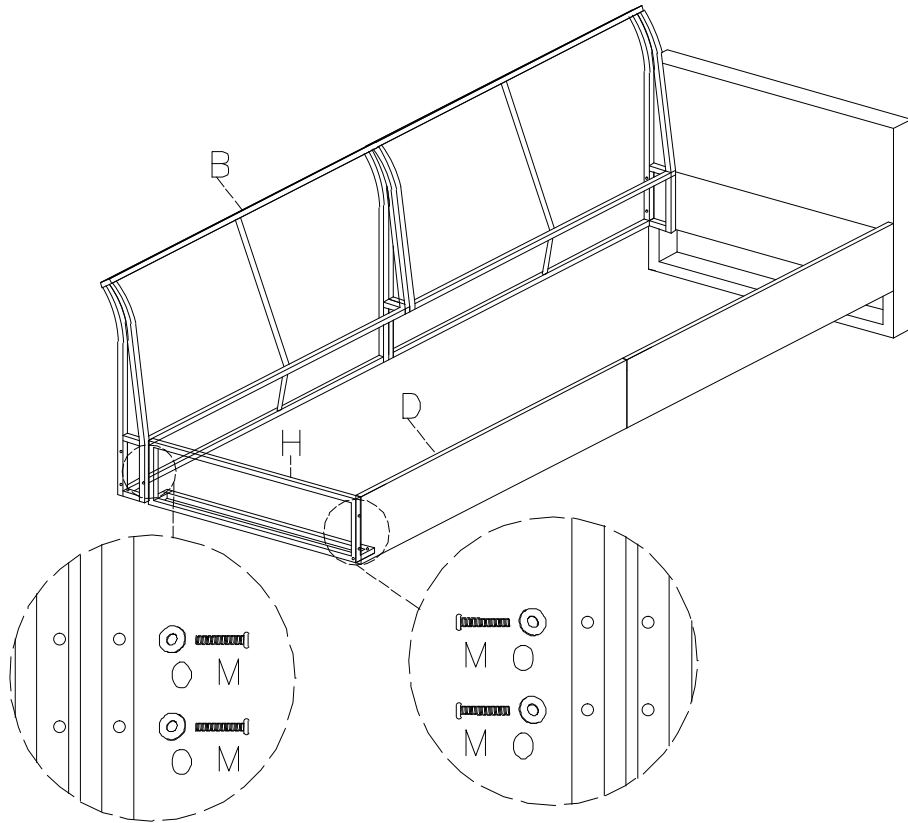

**Step 5:** Attach seat side panel H to back B and front panel D with 4pcs bolts M and 4pcs washers O, using Ratchet wrench P. Note: Don't fully tighten the bolts.

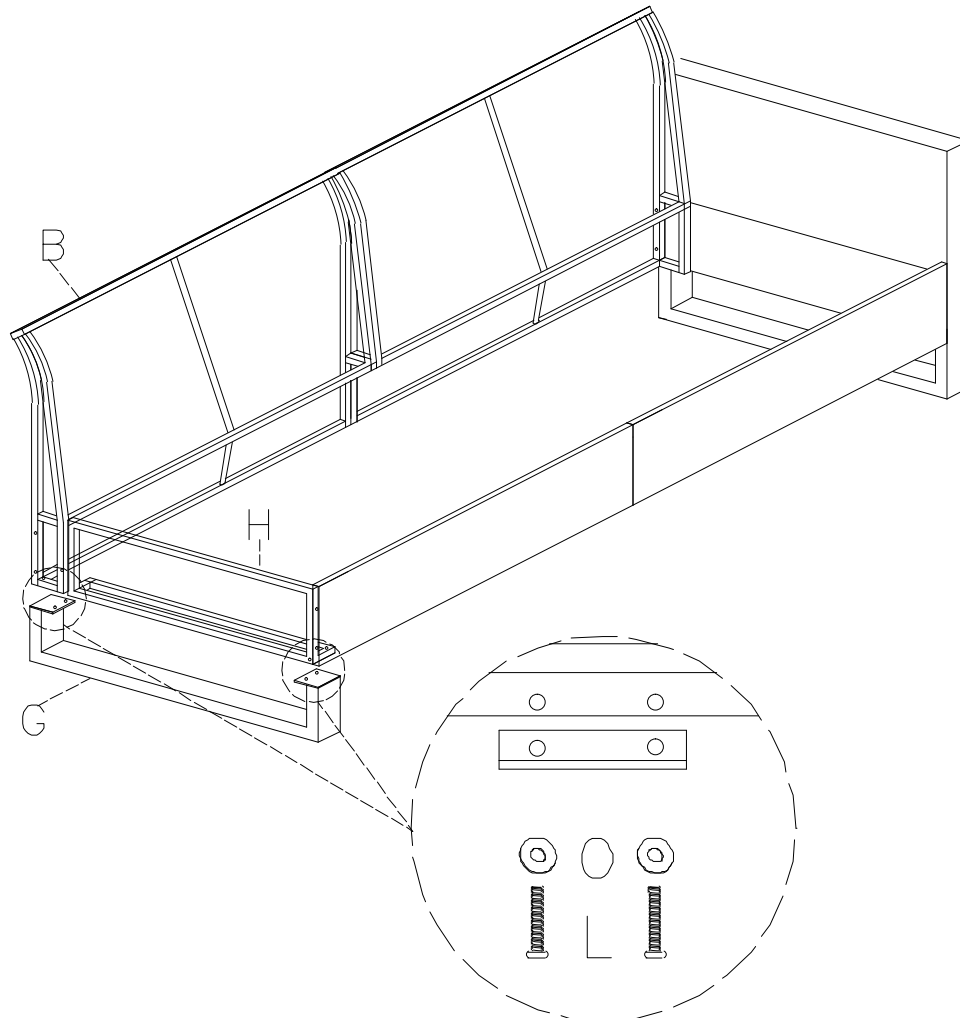

M		M6*35	4
O		M6	4

**Step 6:** Attach foot G to back B and seat side panel H with 4pcs bolts L and 4pcs washers O, using Ratchet wrench P. Note: Don't fully tighten the bolts.



L		M6*20	4
O		M6	4

**Step 6:** Attach seat panels F to back B&C and front panels D&E with 12pcs bolts N and 12pcs washers O, using Ratchet wrench P. Note: Don't fully tighten the bolts.

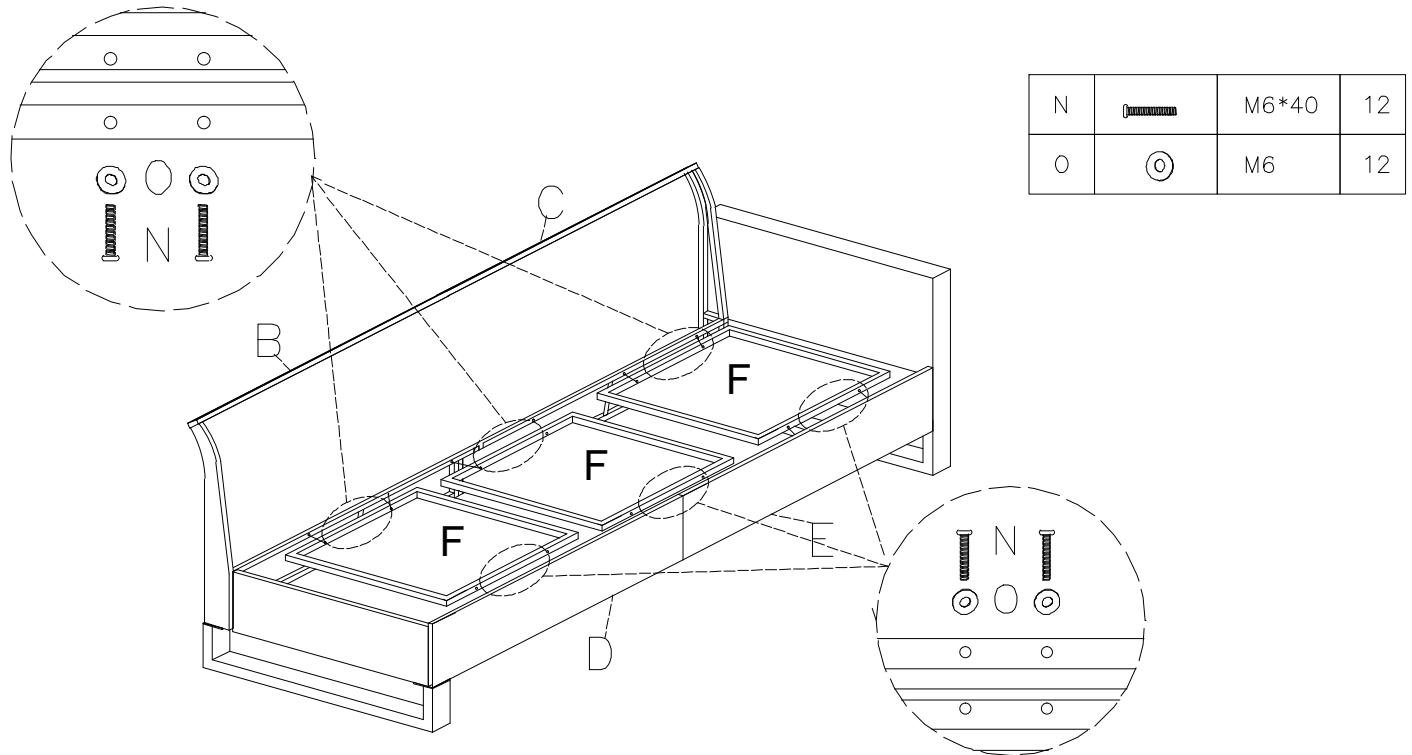

**Step 7:** Attach 2pcs middle feet I to seat panels F with 4pcs bolts L and 4pcs washers O, using Ratchet wrench P. Note: Please fully tighten all the bolts.

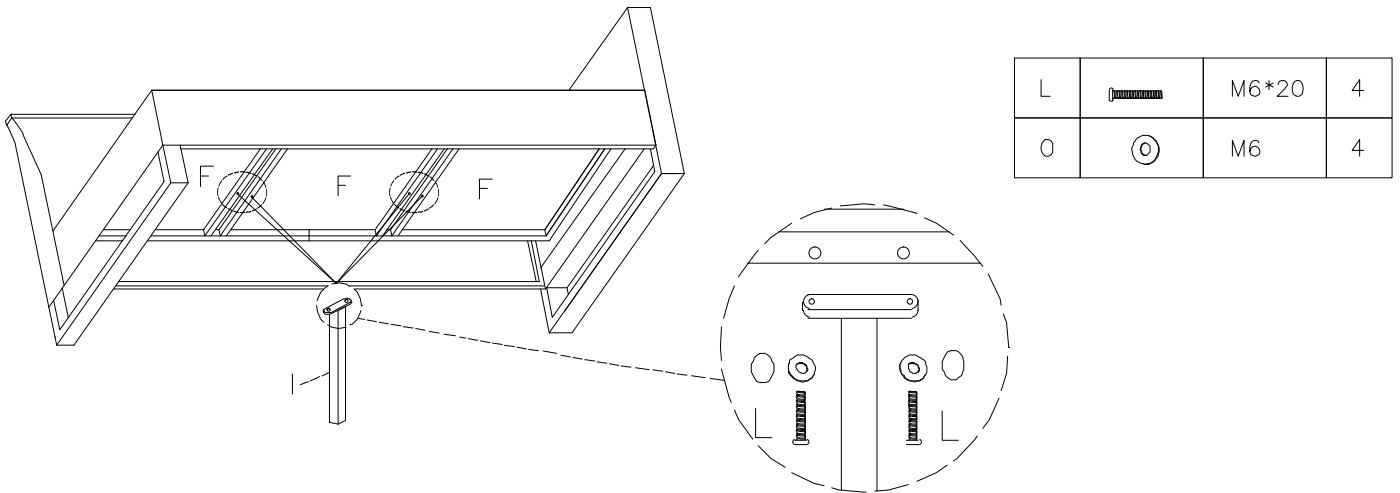

**Step 8:** Put seat cushions K and back cushions J onto the seat. Assembly is now complete and the product is ready for use.

